

P825 Robotic Pool Cleaner

TYPE EM27--

OWNER'S MANUAL

ENGLISH | FRANÇAIS | ESPAÑOL

▲ WARNING

FOR YOUR SAFETY - For anything other than the routine cleaning and maintenance described in this manual, this product must be serviced by a contractor who is licensed and qualified in pool equipment by the jurisdiction in which the product will be installed where such state or local requirements exist. In the event no such state or local requirement exists, the maintainer must be a professional with sufficient experience in pool equipment installation and maintenance so that all of the instructions in this manual can be followed exactly. Improper installation and/or operation will void the warranty.

Table of Contents

English

<p>Section 1. Important Safety Instructions..... 3</p> <p>Section 2. Cleaner Specifications 4</p> <p>Section 3. Assembly and Setup 4</p> <p>3.1 Unpacking 4</p> <p>3.2 Assembling the Transport Caddy 4</p> <p>3.3 Connecting the Control Unit to the Caddy..... 6</p> <p>3.4 Connecting to a Power Source..... 6</p> <p>Section 4. Operation..... 7</p> <p>4.1 The Polaris P825 Cleaner Control Unit 8</p> <p>4.2 Submerging the Cleaner 8</p> <p>4.3 Starting the Cleaner 9</p> <p>4.4 Wall Cleaning (Surface Control System™) 9</p> <p>4.5 Stopping the Cleaner and Removing from the Pool..... 10</p> <p>4.6 Rinsing the Cleaner..... 10</p> <p>4.7 Cleaning the Filter Canister..... 10</p> <p>4.8 Storing the Cleaner 11</p>	<p>Section 5. Maintenance..... 12</p> <p>5.1 Cord Tangling 12</p> <p>5.2 Replacing the Brushes 13</p> <p>5.3 Replacing the Tracks..... 14</p> <p>Section 6. Replacement Parts 14</p> <p>Section 7. Troubleshooting 15</p> <p>7.1 Using the Cleaner Error Indicator..... 15</p> <p>7.2 General Troubleshooting 16</p>
--	---

THANK YOU FOR PURCHASING THE POLARIS CLEANER.

YOUR POLARIS ROBOTIC CLEANER HAS BEEN DESIGNED AND MANUFACTURED TO BE EASILY INSTALLED AND TO PROVIDE LOW MAINTENANCE OPERATION. PRIOR TO INSTALLING YOUR NEW POLARIS CLEANER, PLEASE DO THE FOLLOWING:

- 1) Complete and return the warranty registration card.
- 2) Record your purchase information on the spaces provided below.
- 3) Attach your invoice (or a copy) to this page.

Taking these steps will help ensure prompt warranty service, should it be required. If service is required, please contact your original dealer. If the original dealer does not perform warranty service, please visit www.polarispool.com to locate an independent service company near you. If you are unable to locate a service company, please call our Technical Support department at 1-800-822-7933.

RECORD YOUR POLARIS CLEANER DATA HERE:

Date of Purchase _____ Purchased From _____ Serial Number: _____
(located on machine head)

City _____ State/Province _____ Zip/Postal Code _____

Section 1. Important Safety Instructions

Congratulations on purchasing the Polaris Robotic Cleaner. Please read through the entire manual before installing your new robotic pool cleaner. Your cleaner must be installed and operated as specified.

READ AND FOLLOW ALL INSTRUCTIONS

English

⚠ WARNING

Failure to comply with the following warnings can result in permanent injury, electrocution or death.

PREVENT ELECTRICAL SHOCK

To reduce risk of electrical shock:

- Connect unit to receptacle protected by a ground fault circuit interrupter (GFCI). Such a GFCI receptacle should be provided by a qualified installer and should be tested on a routine basis. To test the GFCI, push the test button. The GFCI should interrupt power. Push the reset button. Power should be restored. If the GFCI fails to operate in this manner, the GFCI is defective. If the GFCI interrupts power to the pump without the test button being pushed, a ground current is flowing, indicating the possibility of an electric shock. Do not use this product. Disconnect the cleaner and have the problem corrected by a qualified service representative before using.
- Per the United States National Electrical Code® (NEC®), keep the control unit at least five (5) feet from the edge of the (pool/spa) water. In Canada, the Canadian Electrical Code (CEC) requires a minimum distance of 3m (10 ft.) to be maintained between the pool edge and the control unit. Never submerge the control unit.
- Do not enter pool while the Polaris cleaner is in water.
- Do not bury cord. Locate cord so as to prevent it from being damaged by lawn mowers, hedge trimmers and other equipment.
- To reduce the risk of electrical shock, do not use the Polaris robotic cleaner or control unit if the cord is worn or damaged. Contact Zodiac Pool Systems, Inc. Technical Support immediately for proper servicing and replacement of the damaged cord.
- Double insulation—For continued protection against possible electric shock, use only identical replacement parts when servicing. Do not attempt repair of the Polaris robotic cleaner, control unit, power cord, or floating cable.
- NEVER OPEN CONTROL UNIT.
- DO NOT USE AN EXTENSION CORD TO CONNECT THE UNIT TO ELECTRIC SUPPLY; PROVIDE A PROPERLY LOCATED GFCI RECEPTACLE. THE CONTROL UNIT SHOULD BE PLACED NEAR THE GFCI RECEPTACLE BOX.

PREVENT CHILD INJURY AND DROWNING

- To reduce the risk of injury, do not permit children to operate this product.
- Do not let anyone, especially small children, sit, step, lean, or climb on any equipment installed as part of your pool's operational system.

⚠ CAUTION

Failure to comply with the following warnings could cause damage to pool equipment or personal injury.

- The Polaris cleaner must be installed and operated as specified.
- This product is intended for use with permanently-installed pools. Do not use with storable pools. A permanently-installed pool is constructed in or on the ground or in a building such that it cannot be readily disassembled for storage. A storable pool is constructed so that it is capable of being readily disassembled for storage and reassembled to its original integrity.
- Clean the filter canister in the Polaris cleaner after each use.
- Do not use the product in your pool if the water temperature is above 95° F (35° C) or below 55° F (13° C).

⚠ CAUTION

USE OF THE POLARIS ROBOTIC CLEANER IN A VINYL LINER POOL

Certain vinyl liner patterns are particularly susceptible to rapid surface wear or pattern removal caused by objects coming into contact with the vinyl surface, including pool brushes, pool toys, floats, fountains, chlorine dispensers, and automatic pool cleaners. Some vinyl liner patterns can be seriously scratched or abraded simply by rubbing the surface with a pool brush. Ink from the pattern can also rub off during the installation process or when it comes into contact with objects in the pool. Zodiac Pool Systems, Inc., is not responsible for, and the Limited Warranty does not cover, pattern removal, abrasion or markings on vinyl liners.

SAVE THESE INSTRUCTIONS

Section 2. Cleaner Specifications

Control box supply voltage	100-240VAC, 60 Hz
Supply voltage	30 V DC
Installed load	150 W max
Cable length	50 ft (15 m)
Cleaner size (WxDxH)	16 x 16.5 x 10 in. (41 x 42 x 25 cm)
Weight of Cleaner	20 lbs. (9 kg)
Filtration	All-purpose filter canister
Cycle lengths	1.5 hr

English

The cleaner is a double-insulated product. A double-insulated electrical appliance is one which has been designed in such a way that it does not require a safety connection to ground. The basic requirement for double-insulation is that no single failure can result in dangerous voltage becoming exposed so that it might cause an electric shock and that this is achieved without relying on an earthed (grounded) metal casing. This is achieved by having two (2) layers of insulating material surrounding live parts or by using reinforced insulation. Therefore, devices having double-insulated construction, such as this cleaner, do not utilize a grounded (three-prong) cord/plug.

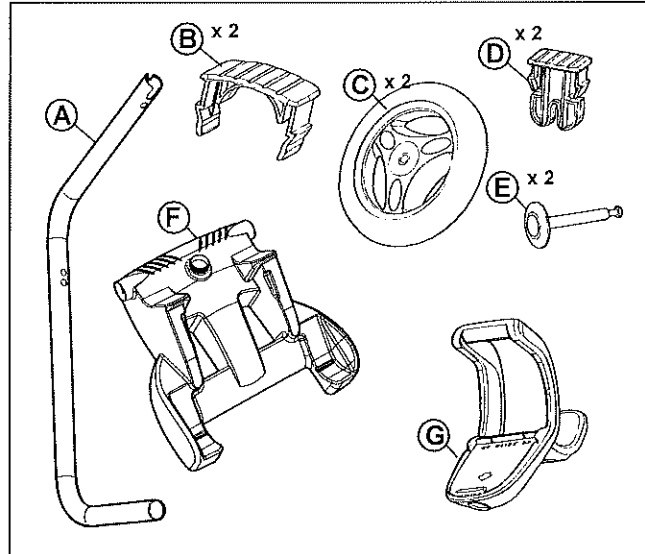

Figure 1. Transport Caddy Assembly Components

When unpacking the cleaner and its components:

- Check to make sure each component is in the box.
- Check cleaner and components for damage.
- If there are missing parts or damage, contact Polaris Technical Support:
USA 1-800-822-7933
Canada 1-888-647-4004 .

Section 3. Assembly and Setup

3.1 Unpacking

The packaging should contain the following items:

- Robotic cleaner and floating power cable
- Control unit with power cord
- Transport and storage caddy assembly components (Figure 1)
 - (a) handle frame
 - (b) support blocks (x 2)
 - (c) wheels (x 2)
 - (d) wheel locking clips (x 2)
 - (e) wheel axle / hubcap (x 2)
 - (f) base unit
 - (g) caddy handle

3.2 Assembling the Transport Caddy

1. Unscrew the handnut from the base unit (Figure 2).

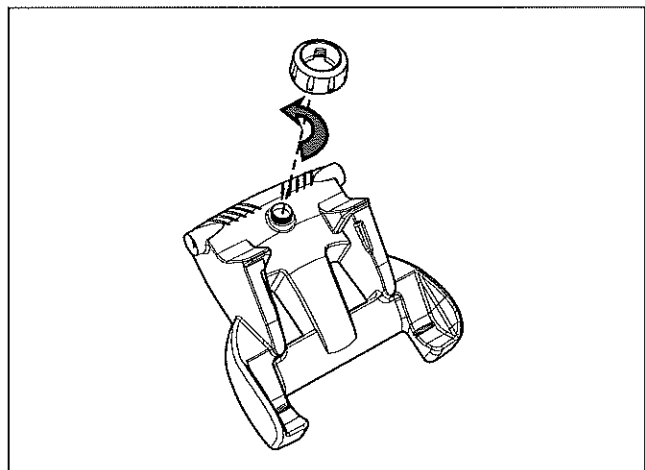

Figure 2. Remove Handnut from Base Unit

2. Insert the metal handle frame tubing into the base unit with notch end at the top, then rotate so the bends are away from you. (Figure 3).

3. Push base unit down (Figure 3) so the metal handle frame is seated in the recess on the underside of the base.

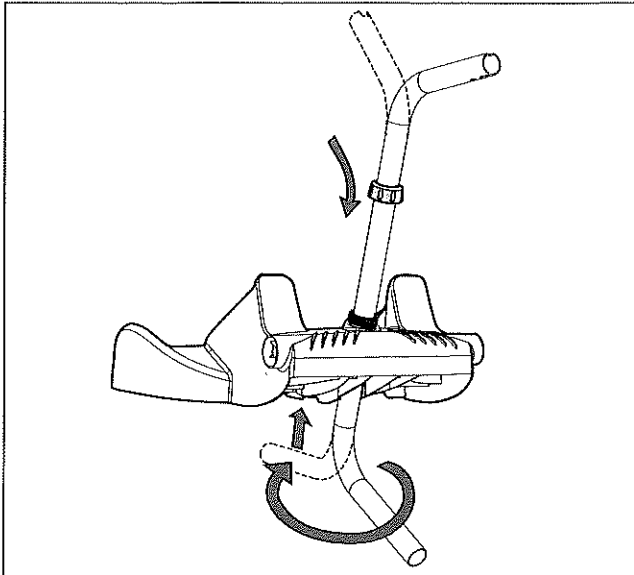

Figure 3. Connect Metal Frame to Base Unit

4. Slide the handnut over the tube and twist to tighten onto base unit (Figure 4).

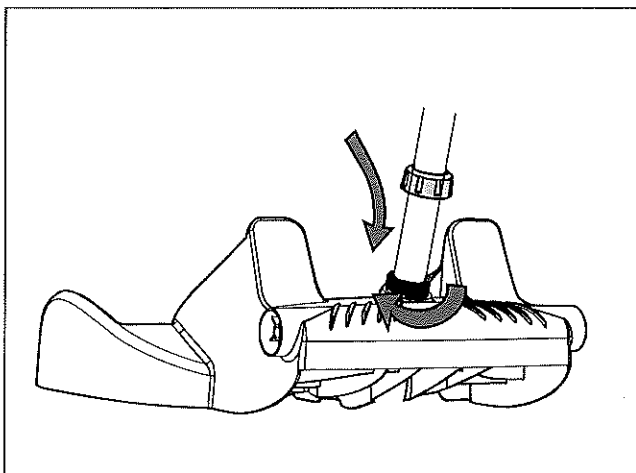

Figure 4. Twist Handnut to Secure Frame

5. Snap two (2) support blocks into place (Figure 5).
6. Slide axle and hubcap piece through center of wheel and attach to base unit. Snap locking clip into place to secure wheel. Repeat to attach both wheels (Figure 5).

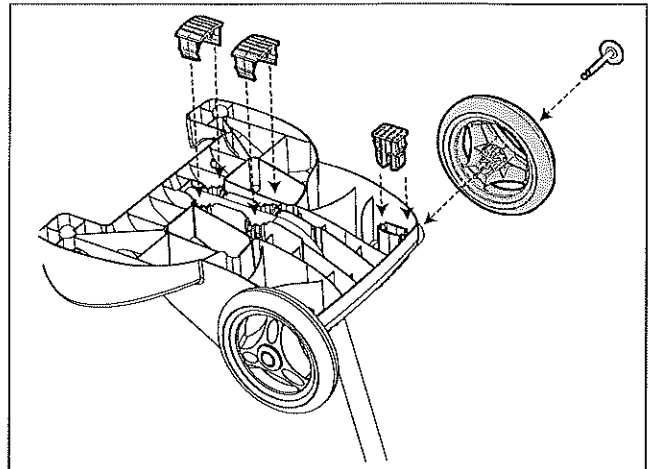

Figure 5. Snap in Support Blocks and Attach Wheels

7. Slide the control unit base / caddy handle attachment down over the metal tubing until it snaps into place. (See Figure 6).

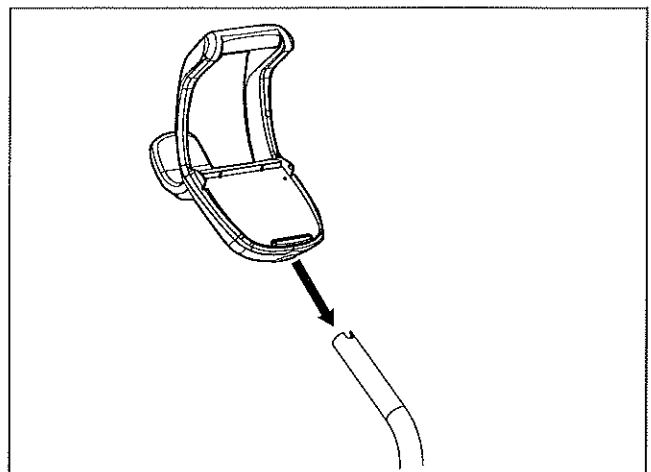

Figure 6. Attach Caddy Handle

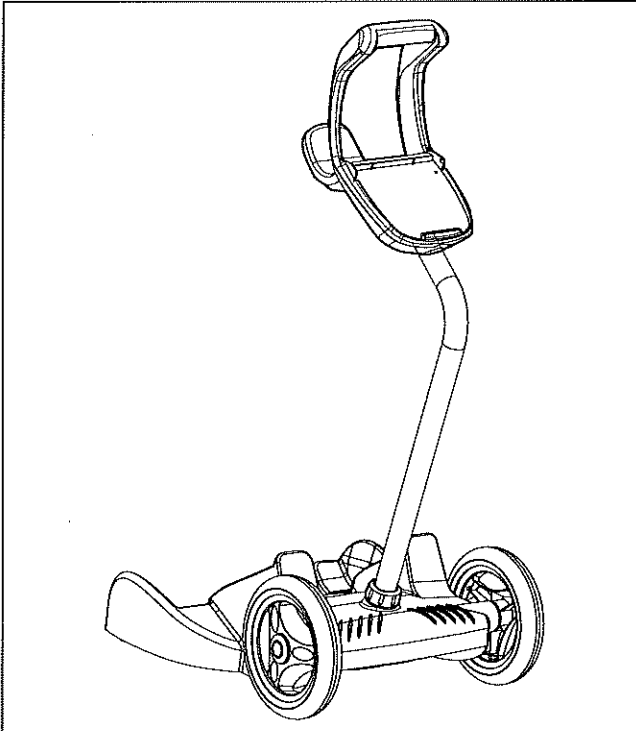

Figure 7. Fully Assembled Transport Caddy

3.3 Connecting the Control Unit to the Caddy

1. Align the bottom of the control unit with the notch at bottom of the control unit hook on the caddy (Figure 8).

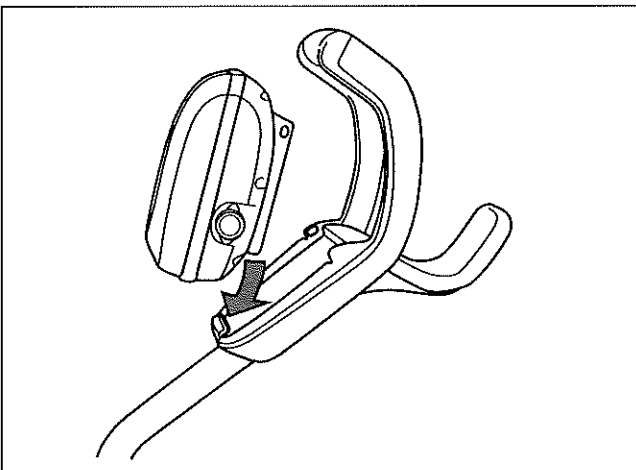

Figure 8. Align Control Unit on Caddy Hook

2. Press control unit onto the caddy hook until it snaps and locks into position (Figure 9).

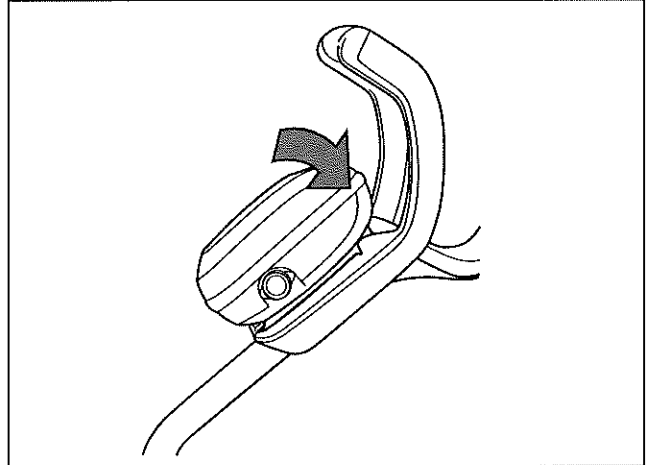

Figure 9. Attach the Control Unit onto Caddy

3.4 Connecting to a Power Source

⚠ WARNING

Failure to comply with the following warnings can result in permanent injury, electrocution or drowning.

PREVENT ELECTRICAL SHOCK

- **U.S.:** Per NEC® requirements, keep the control unit at least five (5) ft. (1.5 m) from the edge of the pool. **CANADA:** Per CEC requirements, keep the control unit at least three (3) m (10 ft.) from the edge of the pool.
- Only connect the control unit to a receptacle protected by a ground fault circuit interrupter (GFCI). Contact a certified electrician if you cannot verify that the receptacle is protected by a GFCI.
- Do not use an extension cord to connect the control unit.
- Do not allow anyone to swim while the cleaner is in the pool.
- The control unit is water-resistant, not waterproof. In order to prevent electrocution, never submerge the control unit or leave exposed to inclement weather.

To Connect:

- Rotate the power cord so that TOP is shown on the top side. Press the power cord firmly into the control unit until you hear a "click" (see Figure 10). The clicking indicates the power cord is connected correctly creating a watertight seal.

Section 4. Operation

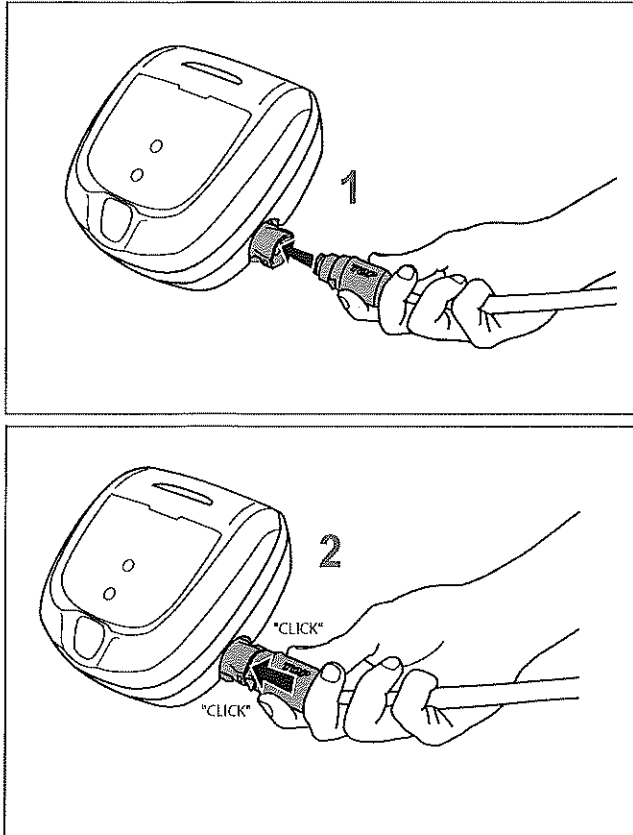

Figure 10. Connect the Power Cord

To Disconnect:

- Grip the power cord firmly on each side and press two tabs to release (see Figure 11.)

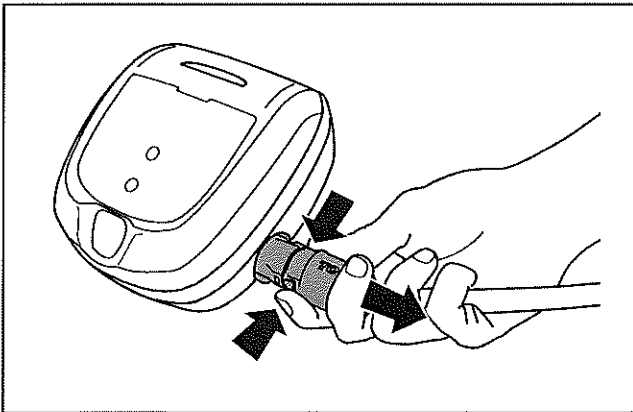

Figure 11. Disconnect the Power Cord

⚠ CAUTION

To prevent damage to the cleaner, be sure to adhere to the following guidelines:

- Remove the cleaner from the pool after the cleaning cycle is completed and store on the caddy out of direct sunlight or inclement weather.
- Never lift the cleaner out of the pool by the floating cable. Always use the handle to remove cleaner from the pool.
- Take additional care when lifting the cleaner out of the pool. It becomes heavier when filled with water.
- Always remove the cleaner from pool when super chlorinating or adding acid.
- Do not handle cleaner while it is in operation.

IMPORTANT

- Always make sure the cleaner head is fully submerged before you begin operation.
- Clean the filter canister after each cleaning cycle.
- Do not leave your cleaner in the pool on a permanent basis.
- At the end of each cycle, remove the cleaner from the pool. Start at the cleaner head and untangle any coils in the cable before storing the cleaner.

When the control unit is powered on with the floating cable attached, the operating time for the current selected cycle is displayed.

The Polaris robotic cleaner includes a safety feature that automatically stops the cleaner if it is powered on but not submerged in water. For pools equipped with a beach area, this safety feature is programmed to drive the cleaner in reverse and back into the pool when the impeller is out of the water.

4.1 The Polaris P825 Cleaner Control Unit

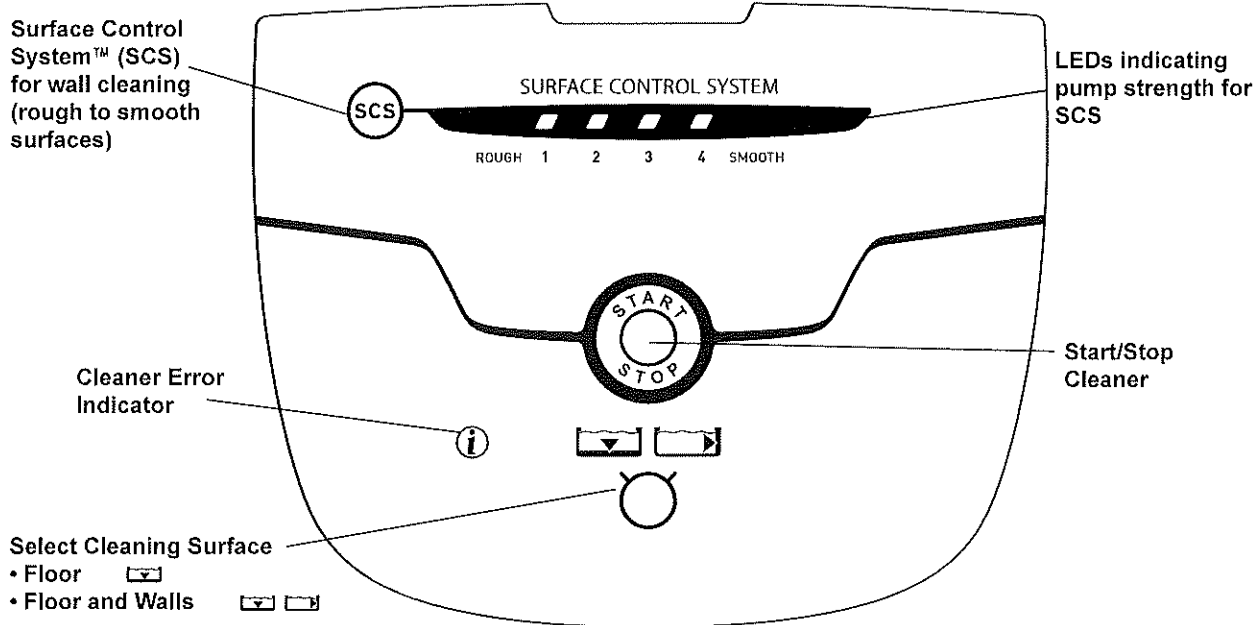

4.2 Submerging the Cleaner

1. Submerge the cleaner vertically (1) and hold it under the surface, moving gently from side to side (2) until the bubbles stop to remove any air trapped inside (see Figure 12).
2. When the bubbles stop, allow the cleaner to sink to the bottom of the pool.
3. Verify the cleaner is sitting on the bottom of the pool. Remove additional air if the cleaner is still floating.

NOTE: The cable side of the cleaner remains up as long as the pump is OFF. As soon as you turn the pump ON, the handle lowers.

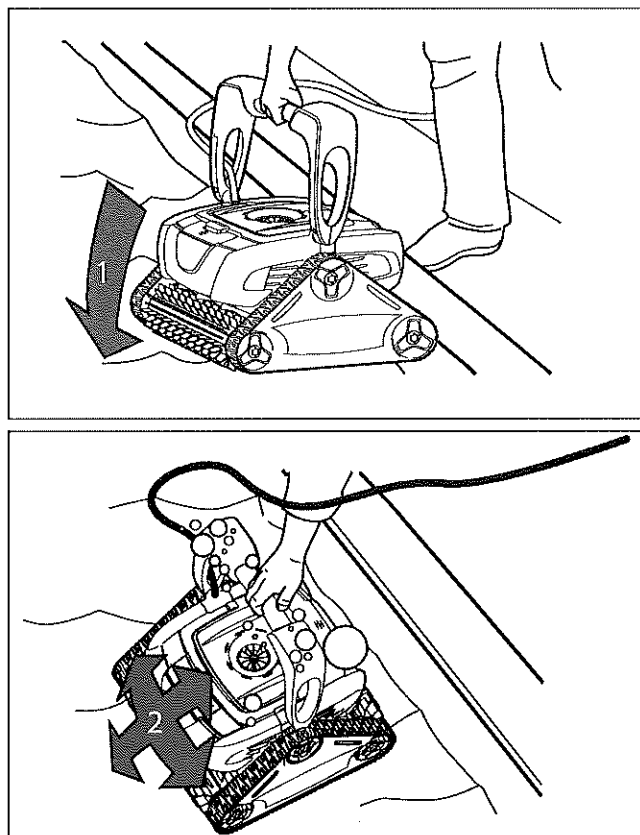

Figure 12. Submerge and Remove Trapped Air

- Spread the floating cable over the pool, making sure there are no kinks or coils in the cable .

NOTE: For optimal patterning and reduced tangling, the floating cable should enter the water near the middle of the pool length. Only place enough cable in the water to reach the farthest point in the pool (see Figure 13).

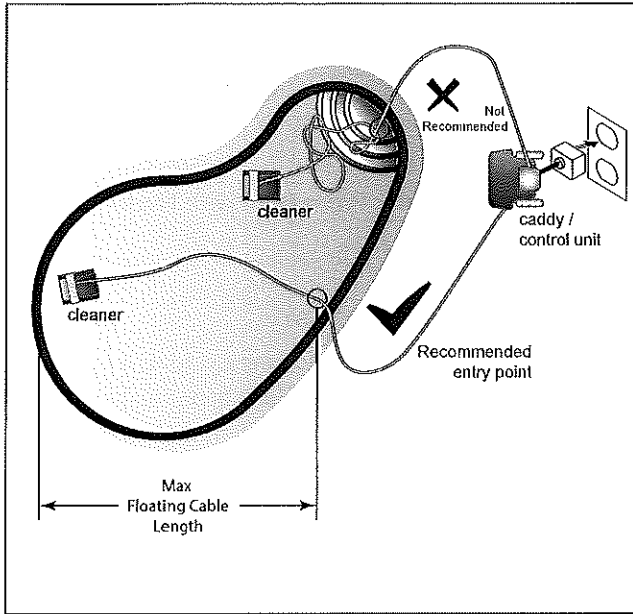

Figure 13. Set Up for Optimal Patterning

4.3 Starting the Cleaner

The first time you use the cleaner, the cleaning surface setting is Floor and Walls .

After the first time, the default is the last setting used.

Select Cleaning Surface:

- Use to change cleaning surface setting.



Begin Cleaning:

- After selecting the cleaning surface, press to begin operation.
- At the beginning of the cycle, the cleaner remains in place for a few seconds to initialize

the microcontroller after the pump starts.

NOTE: Periodically the cleaner will pause for up to 20 seconds throughout the cleaning cycle. The cleaner is calibrating its position in the pool during this process. This is normal operation and the cleaner will resume movement immediately after calibration with no user action required. The pause does not affect the overall cleaning cycle.

4.4 Wall Climbing (Surface Control System™)

The cleaner has the ability to clean the pool walls up to the waterline. How much the cleaner needs to grip to the wall depends upon the pool surface.

Grip Intensity Indicator:

Surface Control System (SCS) settings are as follows for different pool surface types:

- 1 Pebble Surface (ROUGH)
- 2 Concrete
- 3 Vinyl / Fiberglass
- 4 Tile (SMOOTH)

Check Wall Climbing Setting:

- Start the cleaner and watch as the cleaner climbs each wall. If grip setting is correct, the cleaner will easily climb the wall and clean up to the waterline. The default setting is .

NOTE: Wall climbing is programmed in a randomized pattern. Cleaner may climb wall and not reach waterline until third or fourth attempt in order to thoroughly clean wall surface below the waterline first.

- Adjust the wall climbing setting as necessary using the following guidelines:
Increase: if cleaner is climbing the wall slowly and stays below the waterline.
Decrease: if cleaner is climbing the wall too quickly and sucking air at the waterline.

Adjust SCS Wall Climbing Setting:

You can change the wall climbing setting at any time during cleaner operation with the SCS button. The new setting will be active when the cleaner climbs the next wall.

- Press  to adjust the wall climbing setting one level higher.
- One additional LED lights each time you press the button to indicate stronger grip on the wall.
- To decrease setting, press button to cycle through back to one LED (lowest setting).

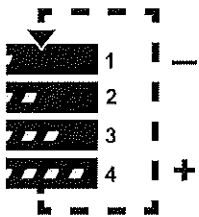

4.5 Stopping the Cleaner and Removing from the Pool

1. If the cleaner is still in operation, press  to interrupt operation. If cleaning cycle is complete, begin at Step 2.
2. When the cleaner is within arm's reach, pull gently on the floating cable to bring the cleaner handle within arm's reach. Use the handle to lift the cleaner from the water (see Figure 14). Never lift the cleaner out of the pool by the floating cable.

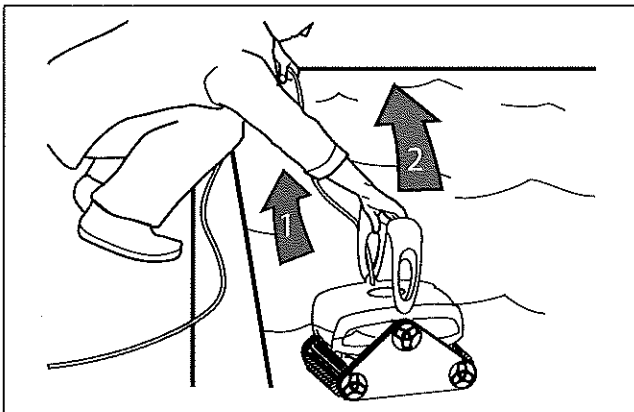

Figure 14. Lift Cleaner From Pool with Handle

3. Hold the cleaner vertically over the pool surface to drain water before removing (see Figure 15).

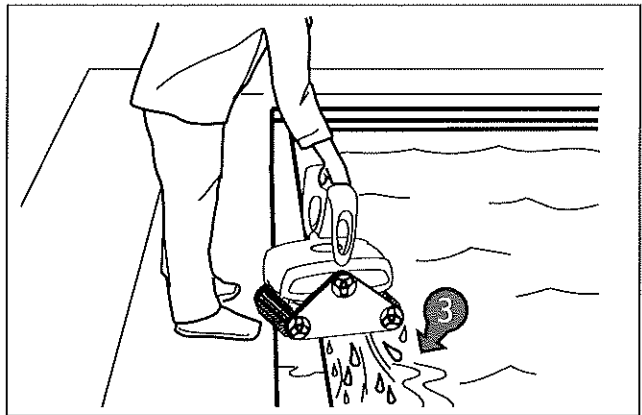

Figure 15. Lift Cleaner From Pool with Handle

4.6 Rinsing the Cleaner

Rinse the cleaner after every cleaning cycle. Use slightly soapy clean water, then rinse generously with clean water. Do not use solvents such as acetone or its equivalent. Do not let your cleaner dry in direct sunlight near the pool.

4.7 Cleaning the Filter Canister

Always empty and clean the filter canister at the end of each cleaning cycle.

WARNING

To avoid electric shock and other hazards which could result in serious injury or death, disconnect (unplug) the cleaner from the power source before performing any cleaning and maintenance.

1. Unplug power to the cleaner at the control unit. Unplug the control unit from the power source.
2. Press the PUSH 'N' GO[®] button to release the filter canister handle (see Figure 16).

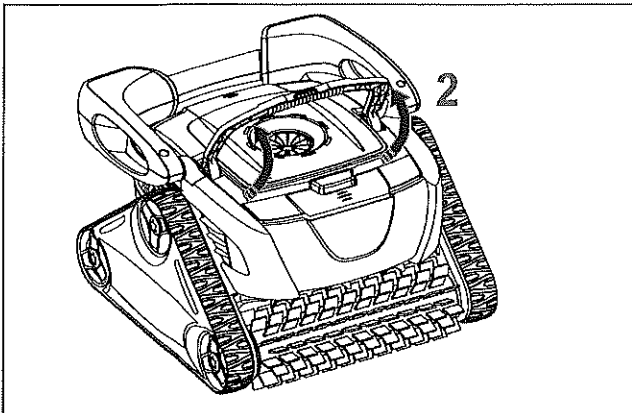
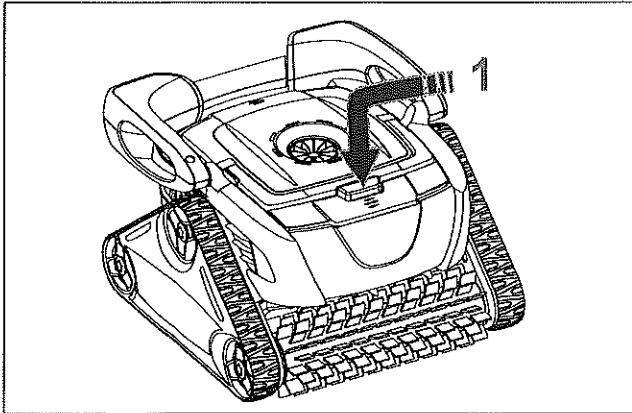

Figure 16. Release Filter Canister Handle

3. Grasp the filter canister handle and lift up to remove the filter canister (see Figure 17).

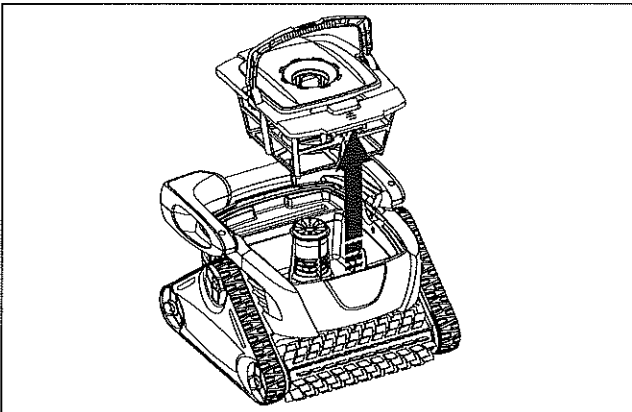

Figure 17. Remove the Filter Canister

4. Press two latches (1) and remove the filter canister lid (2) (See Figure 18).

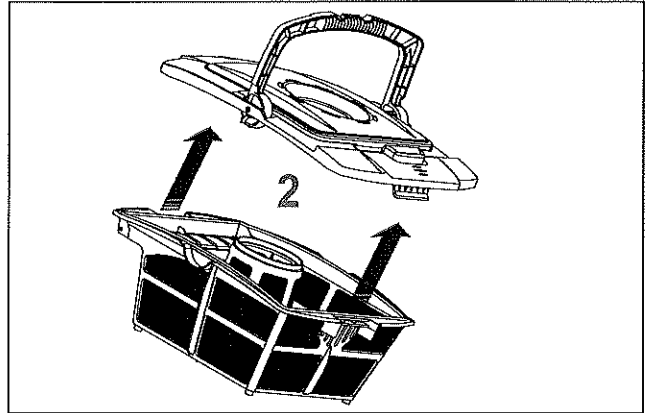
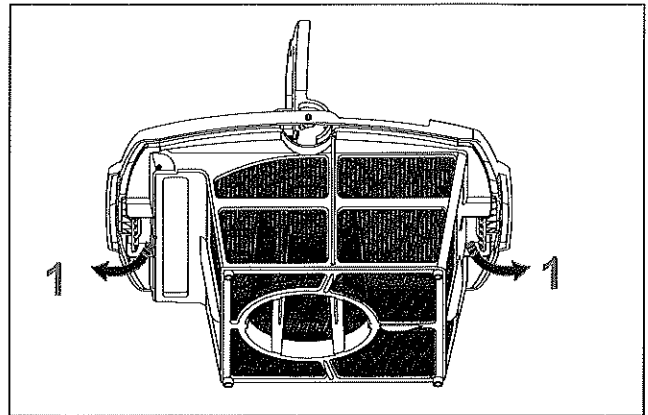

Figure 18. Remove Filter Canister Lid

5. Using a hose with clean water, rinse the filter canister and lid to remove all debris (see Figure 19).

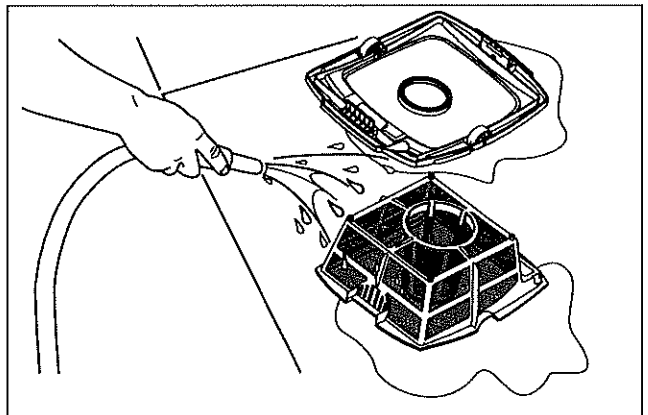

Figure 19. Rinse the Filter Canister

6. Replace lid on the canister and then replace canister back into the cleaner body.

4.8 Storing the Cleaner

The cleaner must be cleaned regularly using slightly soapy clean water. Do not use solvents such as acetone or its equivalent. Rinse the cleaner generously using clean water. Do not let your cleaner dry in direct sunlight near the pool. The cleaner must be stored on its caddy so that it dries quickly.

1. Starting at the cleaner head, Remove all coils and tangles from the cable (see Figure 20).

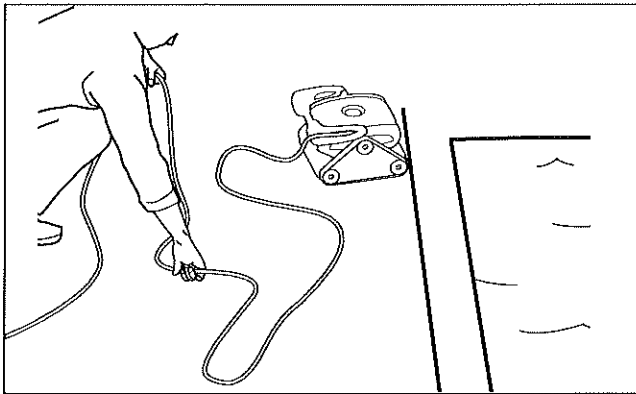

Figure 20. Untangle the Floating cable

2. Place the cleaner in vertical position on the caddy base with the rear tracks on the caddy side wedges (see Figure 21).
3. Loosely coil the power cable starting at the cleaner and moving toward the connection point at control unit. Store the cable by wrapping it around the hook located on the front of the caddy (see Figure 21).

4. Disconnect the cable from the control unit and coil loosely around the caddy hook.
5. If you removed the control unit from the caddy, replace it by aligning the bottom of the control unit with the caddy notch, hook it onto the caddy, then press firmly in place until you hear a "click".

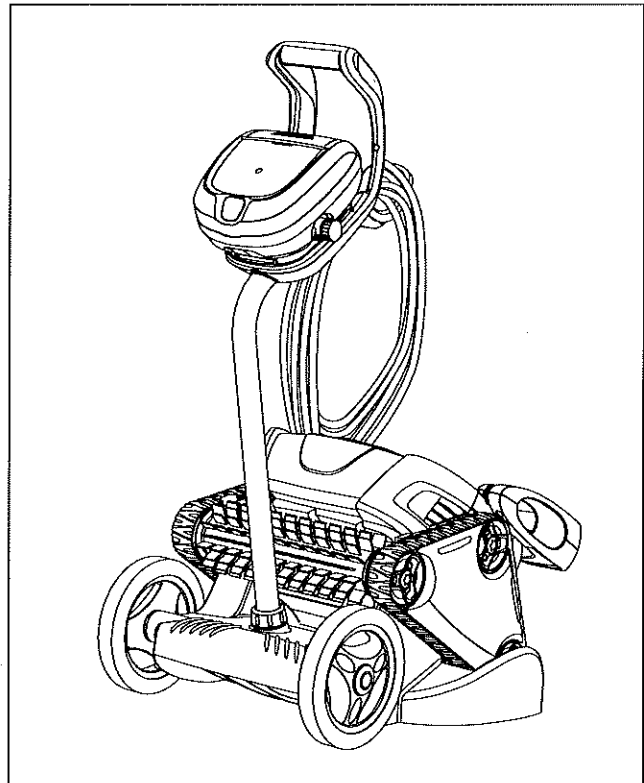

Figure 21. Cleaner Stored Correctly on Caddy

Section 5. Maintenance

WARNING

To avoid electric shock and other hazards which could result in serious injury or death, disconnect (unplug) the cleaner from the power source before performing any cleaning and maintenance.

5.1 Cord Tangling

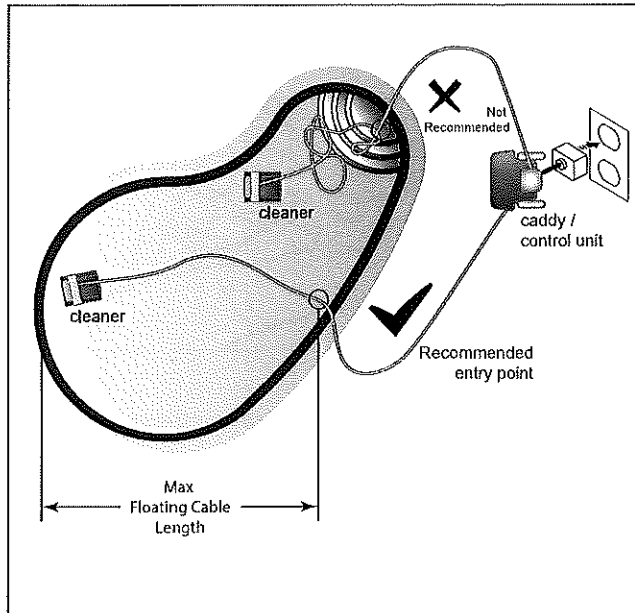

Figure 22. Spread Floating Cable Across Farthest Distance of the Pool

IMPORTANT

The floating cable may become tangled if correct procedure is not followed after each cleaning cycle.

Do not leave the cleaner unattended for prolonged periods and follow the procedure below to avoid excessive tangling.

After every cleaning cycle:

1. Unplug power to the cleaner at the control unit.
2. Remove the cleaner from the pool and untangle all kinks and coils in the floating cable starting at the cleaner head (see Figure 23).
3. Plug power cord back into control unit and store cleaner on the caddy out of direct sunlight for next use.

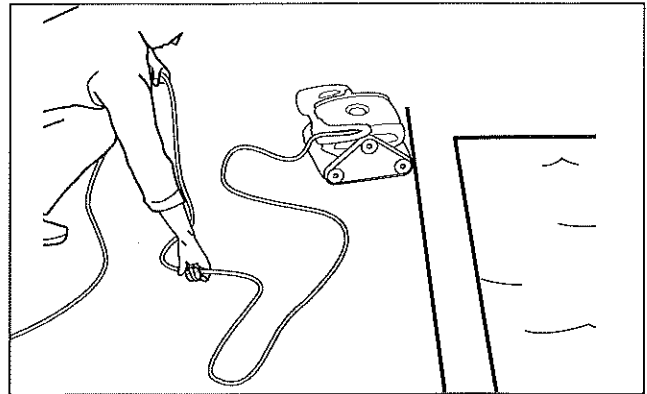

Figure 23. Untangle the Floating cable

5.2 Replacing the Brushes

The cleaner is fitted with PVC brushes in front and rear. There are raised grooves that are "wear" indicators on the brushes located next to the tab connectors (see Figure 24). As brushes wear out, the raised groove will flatten and smoothen into the track. To maintain optimal cleaner performance, you should replace the brushes as soon as one of the wear indicators is smooth or worn down (even if the blade wear is not even). It is recommended that you replace the brushes every two (2) years.

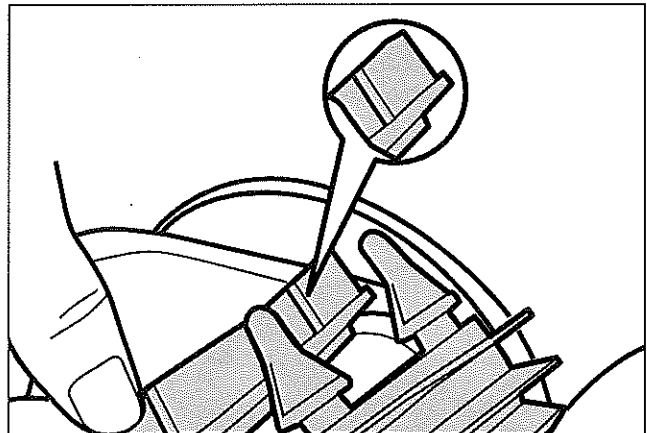

Figure 24. Wear Indicators

1. Stand the cleaner on its end in a vertical position (see Figure 25).

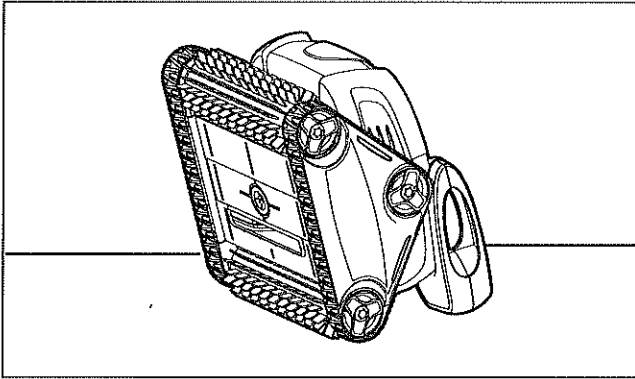

Figure 25. Stand Cleaner Upright

2. Separate the edges of the brush, undo the tabs, and remove the worn brush.
3. Position the new brush underneath the roller with the spikes facing downwards (see Figure 26).

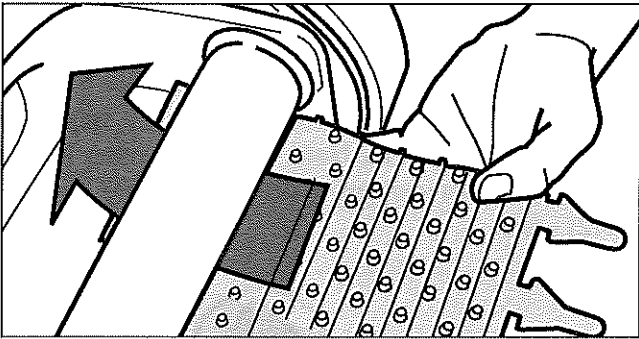

Figure 26. Position the New Brush on Roller

4. Thread each tab into the slot provided and gently feed it through until the heel comes out at the other side of the slot (see Figure 27).

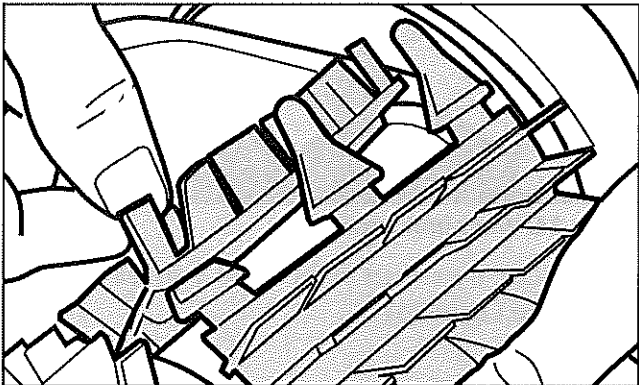

Figure 27. Pull Tabs Through Each Slot

5. Use scissors to cut the tabs so they are no higher than the spikes (see Figure 28).

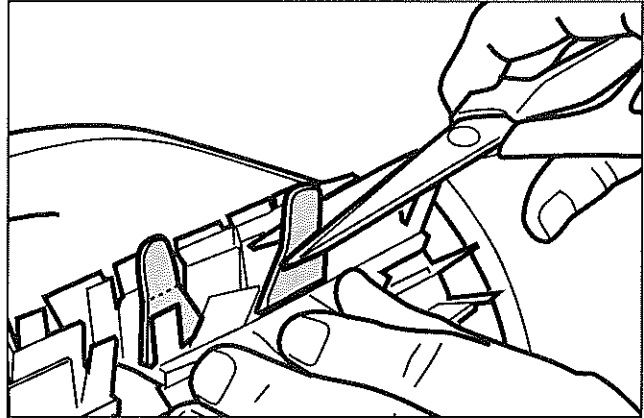

Figure 28. Cut Tabs

6. Repeat this procedure to replace the second brush.

5.3 Replacing the Tracks

1. Stand the cleaner on its side (see Figure 29).

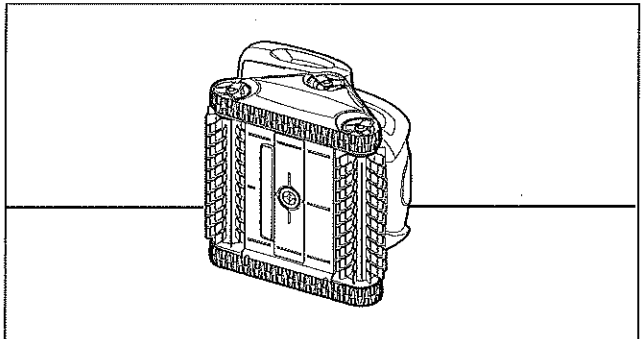

Figure 29. Stand Cleaner on its Side

2. Starting at one of the wheels, pull on the inside of the track to separate the tire lip from the wheel (see Figure 30). Remove the track from the cleaner.

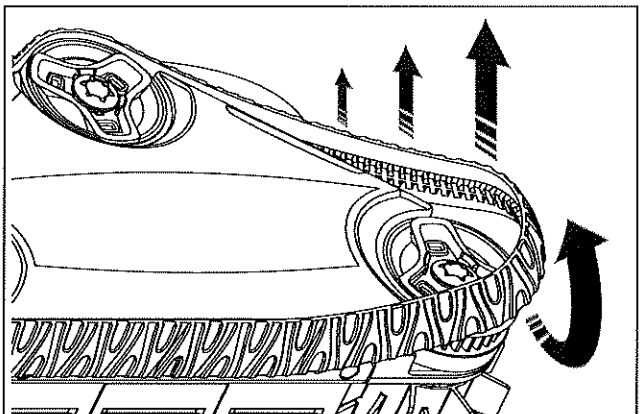

Figure 30. Pull the Track Over Wheels to Remove

3. To install a new track, place the inside rib of the track into the groove in the first wheel (see Figure 31).

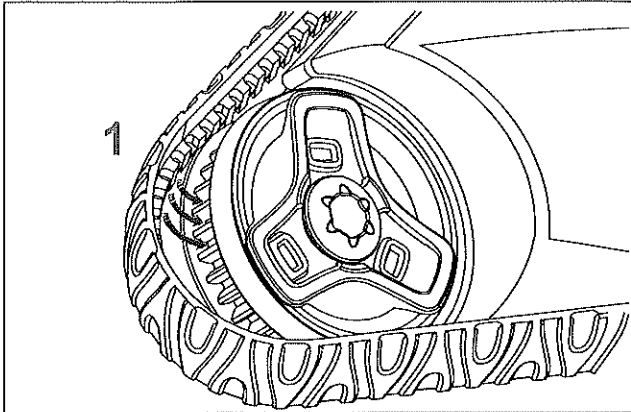

Figure 31. Position Track into Wheel Grooves

4. Stretch the track around the second wheel, then pull over the last wheel (see Figure 32). Push and position the rib of the track so that the track is seated properly in the groove of the wheel.

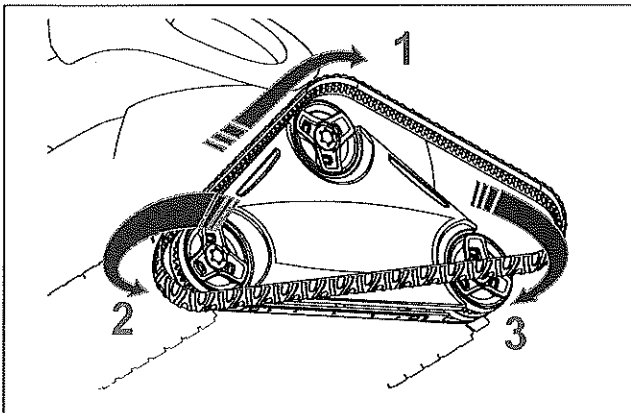

Figure 32. Stretch Track Around Wheels

5. Verify the rib of the track is positioned properly within the groove of each of the three wheels. If necessary, turn the wheels gently to seat track.

Section 6. Replacement Parts

The complete spare parts list and exploded view is available on the Polaris website at www.polarispool.com. In Canada, parts list and exploded view is available at www.polarispool.ca

Section 7. Troubleshooting

7.1 Using the Cleaner Error Indicator

The Cleaner Error Indicator  on the control unit flashes in a specific sequence to indicate one of three possible cleaner malfunctions.

Information LED Flashing	Solution
LED flashes once with one second interval.	Unplug the floating cable from the control unit and reconnect. If the problem is not resolved through troubleshooting, contact Polaris Technical Support at (USA) 1-800-822-7933; 1-888-647-4004 (Canada).
LED flashes twice with one second interval.	Turn cleaner wheels to ensure they are not jammed. Check brushes for debris. Start a new cleaning cycle. If the problem persists, contact Polaris Technical Support at (USA) 1-800-822-7933; 1-888-647-4004 (Canada).
LED flashes three times with one second interval.	Check the pump axis for debris. Check propellor for debris. Clean the filter. Start a new cleaning cycle. If the problem persists, contact Polaris Technical Support at (USA) 1-800-822-7933; 1-888-647-4004 (Canada).

7.2 General Troubleshooting

The following table lists some of the common symptoms, causes, and solutions for correcting cleaner operation problems.

Problem	Cause	Solution
The Cleaner Error Indicator flashes just after start (either pressing Power or Floor/Wall setting button for less than 20 seconds).	Floating cable may not be plugged into the control unit correctly.	Unplug floating cable from the control unit and reconnect.
	Cleaner may not be fully submerged.	Remove cleaner from the pool and re-submerge, see <i>Submerging the Cleaner</i> .
	Cleaner may need to be reset and begin a new cycle.	Press power button OFF, then Floor/Wall setting button to begin a new cycle.
	Propeller may be jammed and not turning correctly.	First contact your local retailer to request a diagnostic review, and if the problem is not resolved contact Polaris Technical Support at (USA) 1-800-822-7933.; 1-888-647-4004 (Canada).
	Tracks may be jammed and not turning correctly.	First contact your local retailer to request a diagnostic review, and if the problem is not resolved contact Polaris Technical Support at (USA) 1-800-822-7933.; 1-888-647-4004 (Canada).
The Cleaner Error Indicator flashes during the cleaning cycle.	Cleaner may be sucking air (lights will appear after 60 seconds air intake).	Remove cleaner from the pool and re-submerge, see <i>Submerging the Cleaner</i> .
The cleaner does not stay firmly on the pool bottom.	There is air in the appliance casing.	Remove cleaner from the pool and re-submerge, see <i>Submerging the Cleaner</i> .
	The filter canister is full or dirty.	Clean the filter canister, see <i>Cleaning the Filter Canister</i> .
	The impeller is damaged.	First contact your local retailer to request a diagnostic review, and if the problem is not resolved contact Polaris Technical Support at (USA) 1-800-822-7933.; 1-888-647-4004 (Canada).
The cleaner does not climb the pool walls or clean up to the waterline.	The filter canister is full or dirty.	Clean the filter canister, see <i>Cleaning the Filter Canister</i> .
	Walls of pool are slippery or slimy. Although the water seems clear, microscopic algae, invisible to the human eye, are present in the pool. As a result the pool walls become slippery and prevent the cleaner from climbing. Check tracks and brushes for wear and replace as necessary.	Adjust Surface Control System™ setting, see <i>Wall Cleaning</i> . Do a shock chlorination treatment to reduce the pH levels in the pool. DO NOT leave the cleaner in the pool during this treatment.
On startup the cleaner does not move.	No power supply to the cleaner.	Check that the outlet to which the control unit is connected is receiving electricity.
	Cleaner has shut down with error code or flashing lights.	Disconnect the control unit and wait at least 20 seconds before reconnecting. If the problem persists, contact Polaris Technical Support at 1-800-822-7933 (USA); 1-888-647-4004 (Canada).

Problem	Cause	Solution
Cleaner stops up to 20 seconds during cleaning cycle.	Cleaner is performing normal calibration operation.	No user action required. The pause does not affect the overall cleaning cycle.
Cable is tangling in the pool	Too much cable length in the water.	Do not unravel the entire cable. Use only the amount needed for the cleaner to cover the pool area. Place the remaining unused cable on the side of the pool. Follow the procedure in <i>Cord Tangling</i> to avoid and correct tangled cord.
The cleaner is not cleaning effectively.	The brushes have become smooth or the "wear" indicator shows.	Replace the brushes following the procedure in <i>Replacing the Brushes</i> .
	Filter canister is full or dirty.	Clean the filter canister following the procedure in <i>Cleaning the Filter Canister</i> .
	Floating cable is excessively coiled or kinked.	Make sure the floating cable is spread out over the pool. Ensure the cable is not too tightly wrapped or coiled when storing. If the problem persists, lay the cable straight in the sun to relax it and remove kinks. Follow the procedure in <i>Cord Tangling</i> to avoid and correct tangled cord.

NOTES

English

Zodiac Pool Systems, Inc.
2620 Commerce Way, Vista, CA 92081
1.800.822.7933 | www.ZodiacPoolSystems.com

POLARIS® and the Polaris 3-wheeled cleaner design are registered trademarks of Zodiac Pool Systems, Inc.

ZODIAC® is a registered trademark of Zodiac International, S.A.S.U., used under license. All other trademarks referenced herein are the property of their respective owners.

©2016 Zodiac Pool Systems, Inc. H0429900 Rev F

