

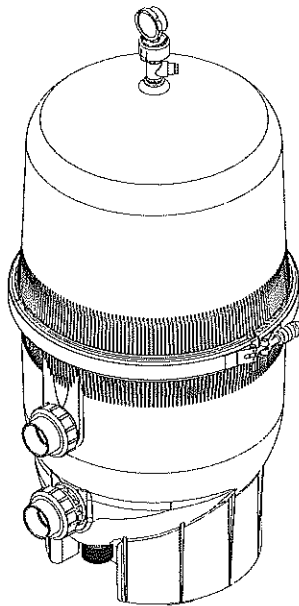

# CLEAN AND CLEAR® PLUS CARTRIDGE FILTER



## INSTALLATION AND USER'S GUIDE

IMPORTANT SAFETY INSTRUCTIONS  
*READ AND FOLLOW ALL INSTRUCTIONS*  
SAVE THESE INSTRUCTIONS



**▲ WARNING**



Pressurized air can cause the lid to separate from the tank with great force. To reduce the risk of severe injury or death, relieve pressure by opening air relief valve before opening filter. Before starting the pump after servicing, ensure that clamp band is correctly fastened. See Important Warnings and Safety Instructions (page iii) and follow all instructions exactly; including the *Opening the Filter* (page 4), *Installing the Filter Lid and Clamp Ring* (page 5), and *Start-Up Instructions* (page 6).

## CUSTOMER SERVICE / TECHNICAL SUPPORT

---

If you have questions about ordering Pentair Aquatic Systems replacement parts, and pool products, please contact:

### Customer Service and Technical Support, USA

(8 A.M. to 4:30 P.M. — Eastern/Pacific Times)

Phone: (800) 831-7133

Fax: (800) 284-4151

### Web site

Visit [www.pentairpool.com](http://www.pentairpool.com) or [www.staritepool.com](http://www.staritepool.com) for information about Pentair products.

### Sanford, North Carolina (8 A.M. to 4:30 P.M. ET)

Phone: (919) 566-8000

Fax: (919) 566-8920

### Moorpark, California (8 A.M. to 4:30 P.M. PT)

Phone: (805) 553-5000 (Ext. 5591)

Fax: (805) 553-5515

## TABLE OF CONTENTS

---

<b>For Your Safety</b> .....	<b>i</b>	<b>Maintenance</b> .....	<b>7</b>
<b>Customer Service / Technical Support</b> .....	<b>ii</b>	Maintaining the Pressure Gauge	7
<b>Important Warnings and Safety Instructions</b> ....	<b>iii</b>	Cleaning the Manual Air Relief Valve	7
<b>General Information</b> .....	<b>1</b>	When to Clean Your Filter	8
Filter Overview	1	Cleaning the Filter Cartridges	8
General Operation Information	1	Acid Soaking the Filter Cartridges	9
Pressure Tests	1	Replacing Filter Cartridges	10
<b>Installation</b> .....	<b>2</b>	<b>Troubleshooting</b> .....	<b>11</b>
Filter Location	2	<b>Technical Data</b> .....	<b>12</b>
Filter Plumbing	2	Flow Rates	12
Installing the Manual Air Relief Valve	3	Dimensional Drawings	12
<b>Opening, Closing and Start-Up</b> .....	<b>4</b>	<b>Replacement Parts</b> .....	<b>13</b>
Opening the Filter	4	Illustrated Parts View	13
Installing the Filter Lid and Clamp Ring	5	Parts List	14
Start-Up Instructions	6	On-Product Safety Labels	15

## IMPORTANT WARNINGS AND SAFETY INSTRUCTIONS



### IMPORTANT NOTICE:

This guide provides installation and operation instructions for the Clean and Clear® Plus Cartridge Filter. Consult Pentair Water Pool and Spa, Inc. with any questions regarding this equipment.

**Attention Installer:** This guide contains important information about the installation, operation and safe usage of this product. This information should be given to the owner and/or operator of this equipment after installation.

**Attention User:** This manual contains important information that will help you in operating and maintaining this filter. Please retain it for future reference.



This is the safety alert symbol. When you see this symbol on your system or in this manual, look for one of the following signal words and be alert to the potential for personal injury.



Warns about hazards that can cause death, serious personal injury, or major property damage if ignored.



Warns about hazards that may cause death, serious personal injury, or major property damage if ignored.



Warns about hazards that may or can cause minor personal injury or property damage if ignored.

### NOTE

Indicates special instructions not related to hazards.

Carefully read and follow all safety instructions in this manual and on equipment. Keep safety labels in good condition; replace if missing or damaged.

### Consumer Information and Safety

This filter is designed and manufactured to provide many years of safe and reliable service when installed, operated and maintained according to the information in this manual and the installation codes referred to in later sections. Throughout the manual, safety warnings and cautions are identified by the “⚠” symbol. Be sure to read and comply with all of the warnings and cautions.



Before installing this product, read and follow all warning notices and instructions which are included. Failure to follow safety warnings and instructions can result in severe injury, death, or property damage. Call (800) 831-7133 for additional free copies of these instructions or replacement safety labels.



Do not operate the filter until you have read and understand clearly all the operating instructions and warning messages for all equipment that is a part of the pool circulating system. The following instructions are intended as a guide for initially operating the filter in a general pool installation. Failure to follow all operating instructions and warning messages can result in property damage or severe personal injury or death.



Due to the potential risk that can be involved it is recommended that the pressure test be kept to the minimum time required by the local code. Do not allow people to work around the system when the circulation system is under pressure test. Post appropriate warning signs and establish a barrier around the pressurized equipment. If the equipment is located in an equipment room, lock the door and post a warning sign.

Never attempt to adjust any closures or lids or attempt to remove or tighten bolts when the system is pressurized. These actions can cause the filter to separate and could cause severe personal injury or death if they were to strike a person.



This filter must be installed by a qualified pool serviceman in accordance with all applicable local codes and ordinances. Improper installation could result in death or serious injury to pool users, installers, or others and may also cause damage to property.



Always disconnect power to the pool circulating system at the circuit breaker before servicing the filter. Ensure that the disconnected circuit is locked out or properly tagged so that it cannot be switched on while you are working on the filter. Failure to do so could result in serious injury or death to serviceman, pool users or others due to electric shock.



DO NOT permit children to use this product.

## IMPORTANT WARNINGS AND SAFETY INSTRUCTIONS

### **▲ WARNING**



#### **THIS SYSTEM OPERATES UNDER HIGH PRESSURE**

When any part of the circulating system, (e.g., closure, pump, filter, valve(s), etc.), is serviced, air can enter the system and become pressurized. Pressurized air can cause the top closure to separate which can result in severe injury, death, or property damage. To avoid this potential hazard, follow these instructions:

1. Let air and pressure out of system before and after servicing.
  - a. **Shut off pump and RELIEVE PRESSURE by opening the manual air/pressure relief valve before servicing, including before tightening the clamp bolt.** Follow the *Opening the Filter* instructions exactly (page 4).
  - b. Follow *Start-Up Instructions* exactly after completing service (page 6). **The air/pressure relief valve must remain open until water comes out, allowing all air out of the system.**
2. Install lid and clamp ring properly.
  - a. Follow the *Installing the Filter Lid and Clamp Ring* instructions exactly (page 5). **The nut must be tightened until the spring is compressed when clamp is installed.** Tap the clamp with a rubber mallet or similar tool after clamp installation to ensure proper seating.
3. Maintain circulation system properly to help prevent air entering the system.
  - a. Replace worn or damaged parts immediately, (e.g., closure, pressure gauge, valve(s), O-rings, etc.).
  - b. Maintain proper water level in the pool or spa.
4. Verify that the return line to the pool is unobstructed. Ensure return valves are open and any winterizing plugs are removed.

### **▲ WARNING**

#### **AVOID DAMAGING SYSTEM**

**Never Exceed Maximum Pressure of Components.** The maximum working pressure of this filter is 50 psi. Never subject this filter to higher pressure, even when conducting hydrostatic pressure tests. Pressures above 50 psi can damage your filter.

Be sure the maximum pressure of the filter system does not exceed the maximum pressure of any components within the system (typically stated on each component), including during hydrostatic or external leak tests. Exceeding the maximum pressure of a component can result in that component failing. If you do not know the pool or spa system operating pressure, install an ASME approved automatic Pressure Relief or Pressure Regulator in the circulation system set to the lowest working pressure of any of the components in the system.

### **▲ WARNING**



Certain codes may require pressure testing the system. Performing pressure tests increases the risk of component failure. Due to the potential risk that can be involved, keep the pressure test to the minimum time required by the local code and take precautions. If pressure testing is necessary, follow these precautions:

1. Keep people away.
  - a. Do not allow people to work around the system when the circulation system is under pressure test. Post appropriate warning signs and establish a barrier around the pressurized equipment. If the equipment is located in an equipment room, lock the door and post a warning sign.
2. Never exceed maximum operating pressure.
  - a. When performing hydrostatic pressure tests or when testing for external leaks of the completed filtration and plumbing system, ensure that the Maximum Pressure that the filtration system will be subjected to does not exceed the maximum working pressure of any of the components contained within the system.

# GENERAL INFORMATION

## **WARNING**



### **THIS SYSTEM OPERATES UNDER HIGH PRESSURE.**

When any part of the circulating system (e.g., Lock Ring, Pump, Filter, Valves, etc.) is serviced, air can enter the system and become pressurized. Pressurized air can cause the lid to separate which can result in serious injury, death, or property damage. To avoid this potential hazard, follow the instructions below.

## Filter Overview

- Large filter area designed for increased debris capacity
- NSF Listed
- High Flow™ Manual Air Relief Valve provided
- 1.5" x 2" Bulkhead Unions allows for easy piping installation

## General Operation Information

Read and follow all instructions and warnings before installing or servicing your filter. Proper installation and operation can prevent unnecessary repairs and maintenance.

## **WARNING**



Your filter is a piece of machinery, do not tamper with it, attempt to disassemble it or otherwise adjust it unless you fully understand it's operation. Serious injury or death can occur if the equipment is improperly handled. Consult a pool service professional for maintenance and service assistance.

1. The Clean and Clear® Plus Cartridge Filter operates under pressure and operates in a safe manner if clamped properly and without air in the circulating system.
2. The maximum working pressure of this filter is 50 psi. Never subject this filter to pressure in excess of this amount, even when conducting hydrostatic pressure tests.
3. Be sure the maximum pressure of the filter system does not exceed the maximum pressure of any components within the system during hydrostatic or external leak tests. Consult the maximum pressure stated on each component of the system.
4. The pressure gauge is the primary indicator of how the filter is operating. Maintain your pressure gauge in good working order.
5. **Clean your filter when pressure reads between 8-10 psi higher than the "Original Starting Pressure", or when significant reduction in flow is noticed.** The pressure reading increases as it filters dirt from your pool. This build up of pressure will vary due to different bathing loads, temperature, environmental conditions, etc.

**Note:** When using a variable speed pump the "Original Starting Pressure" will be dependent on the pump speed (RPM) when recording the original operating pressure. Record the "Original Pump RPM" in **Table 1**.

## Pressure Tests

When performing hydrostatic pressure tests or when testing for external leaks of the completed filtration and plumbing system, ensure that the Maximum Pressure that the filtration system will be subjected to **DOES NOT EXCEED THE MAXIMUM WORKING PRESSURE OF ANY OF THE COMPONENTS CONTAINED WITHIN THE SYSTEM.** In most cases, the maximum pressure will be stated on each component of the system.

If you do not know the pool or spa system operating pressure, install an ASME approved automatic Pressure Relief or Pressure Regulator in the circulation system set to the lowest working pressure of any of the components in the system.

**Table 1**

ORIGINAL STARTING PRESSURE IS: \_\_\_\_\_ psi.  
(pounds per square inch)

SERVICE THE MEDIA AT: \_\_\_\_\_ psi.

ORIGINAL PUMP RPM: \_\_\_\_\_ rpm.  
(for Variable Speed Pumps Only)

## INSTALLATION



**WARNING** This filter must be installed by a qualified pool technician in accordance with all applicable local codes and ordinances. Improper installation could result in death or serious injury to pool users, installers, servicers, or others and may also cause damage to property.



**WARNING** For Installation of Electrical Controls at Equipment Pad (ON/OFF Switches, Timers, Control Systems and Automation) Install all electrical controls at the equipment pad, such as ON/OFF switches, timers, control systems, etc. to allow the operation (startup, shutdown or servicing) of any pump or filter so the user does not place any portion of his/her body over or near the pump strainer lid, filter lid or valve closures. This installation should allow the user enough space to stand clear of the filter and pump strainer lid during system startup, shutdown or servicing of the system filter.

### Filter Location

1. The Clean and Clear® Plus Cartridge Filter should be mounted on a level concrete slab. **Position the filter so that instructions, warnings and the pressure gauge are visible to the operator and readable.** It also should be positioned so that the piping connections, control valve and waste drain plug are convenient and accessible for servicing and winterizing.
2. Be certain to install electrical controls (e.g., on/off switches, timers, control systems, etc.) so that the user is allowed enough space to stand clear of the filter and pump during startup, shutdown or servicing.
3. Allow sufficient clearance around the filter to permit visual verification that the clamp is properly installed around the tank flanges, see **Figure 1**.

**Note:** See page 5, *Installing the Filter Lid and Clamp Ring*.

4. Allow sufficient space above the filter to remove the filter lid for cleaning and servicing. This distance will vary with the model of filter you are using. See **Table 2** for the required vertical clearance.
5. Position the filter to safely direct water drainage away from electrical equipment or anything that might be damaged.
6. Position the High Flow™ Manual Air Relief Valve to safely direct purged air or water (See page 3, *Installing the Manual Air Relief Valve*).

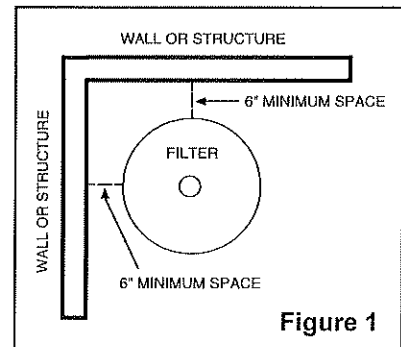

**Figure 1**

**Table 2**

Model No.	Size	Vert. Clearance Req. (From Ground Level)
CCP240	240 sq. ft.	56in.
CCP320	320 sq. ft.	62in.
CCP420	420 sq. ft.	68in.
CCP520	520 sq. ft.	74in.



**WARNING** RISK OF ELECTRICAL SHOCK OR ELECTROCUTION. Water discharged from an improperly positioned filter or valve can create an electrical hazard that can cause severe personal injury as well as damage property.

### Filter Plumbing

Make all plumbing connections in accordance with local plumbing and building codes. Do not use pipe joint compound, glue or solvent on the bulkhead connections. The provided filter plumbing connections include an O-ring seal.



**CAUTION** Use PTFE or silicone based lubricants when lubricating the O-rings on the union and bulkhead couplings. Use of petroleum based products will damage the equipment.

## Installing the Manual Air Relief Valve

**WARNING** The High Flow manual air relief valve and pressure gauge are included with this filter to help ensure safe operation of the equipment. Always maintain these components in good working condition.

1. Remove the High Flow™ Manual Air Relief Valve and the pressure gauge from the accessories package included with your Clean and Clear® Plus Cartridge Filter.
2. Thread the manual air relief valve into the threaded hole at the top of the filter tank.

**Note: Hand tighten only!** Over tightening the valve can cause damage to the tank or valve connection threads.

3. Verify that the valve is positioned to safely direct purged air or water away from electrical equipment or anything that might be damaged.

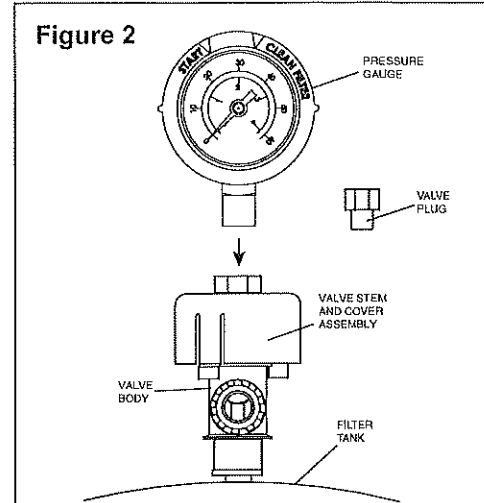

**WARNING**



**RISK OF ELECTRICAL SHOCK OR ELECTROCUTION.** Water discharged from an improperly positioned filter or valve can create an electrical hazard that can cause severe personal injury as well as damage property.

4. Remove the plug from the top of the manual air relief valve with a 9/16" wrench.
5. Wrap the pressure gauge connection threads with thread seal tape (two full wraps of tape will be enough).
6. Thread the pressure gauge into the top of the manual air relief valve. **Hand tighten only!**
7. Follow *Start-up Instructions* exactly (page 6).

## OPENING, CLOSING, AND START-UP

### CAUTION

The following information should be read carefully since it outlines the proper manner of care and operation for your filter system. As a result of following these instructions and taking the necessary preventative care, you can expect maximum efficiency and life from your filtration system.

### Opening the Filter

Follow these instructions **exactly** to prevent the lid from separating during system start-up, operation or servicing.

### WARNING



This filter operates under high pressure. Air can also enter the system and become pressurized.

If there is air in the system, there will be positive pressure that could cause the lid to separate from the filter when you release the clamp or during system start-up or operation (see Important Warnings and Safety Instructions, page ii-iii).

If there is no air in the system, there may be negative pressure, which would make the system hard to open.

Follow these instructions **exactly** - opening the relief valve equalizes the pressure and releases any trapped air within the system, making it safe and easy to open.

### RECOMMENDED EQUIPMENT:

- Ratchet Wrench
- 7/8" Socket
- Socket Extender (if needed)

### PROCEDURE:

1. Shut off pump and relieve pressure.
  - a. Turn the pump OFF, shut OFF any automatic controls (e.g., timers), and disconnect power to ensure that the system is not inadvertently started during maintenance.
  - b. Open the High Flow™ Manual Air Relief Valve by turning the valve cover assembly counter-clockwise until it snaps into the full open position.
  - c. Stand clear of the filter and wait until all pressure is relieved. Pressure gauge must read zero (0 psi).
2. Open the waste drain plug on the bottom of the Clean and Clear® Plus Cartridge Filter. Allow all water to drain from the bottom of the filter tank.
3. Loosen the clamp's barrel nut with a 7/8" wrench, allowing the spring coils to decompress. See **Figure 4**. Remove the barrel nut, spring and two washers from the T-bolt and place them in a safe place where they will not be lost.
4. Once the spring has fully decompressed the clamp assembly will rest in the open position. Carefully lift the filter lid straight up from the lower body of the filter. If the lid is tightly sealed to the filter body you may have to gently push the filter lid from side to side in order to separate the lid from the bottom tank manifold.

### CAUTION

DO NOT use the relief valve as a handle or lever since this may damage the valve.

5. Place the tank lid in a safe place where it will not be damaged while performing any maintenance.

**NOTE:** Attempt to minimize the amount of debris that comes in contact with the tank O-ring while it is exposed. This will help prolong the life of the O-ring.

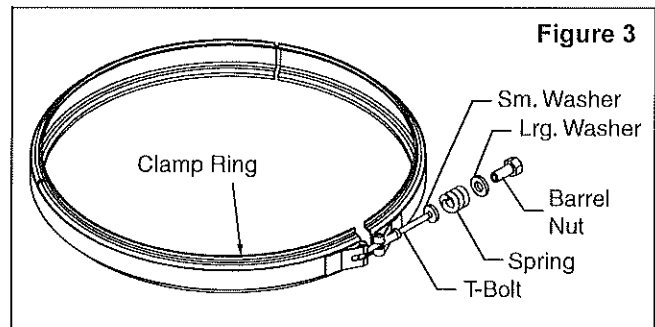

Figure 3

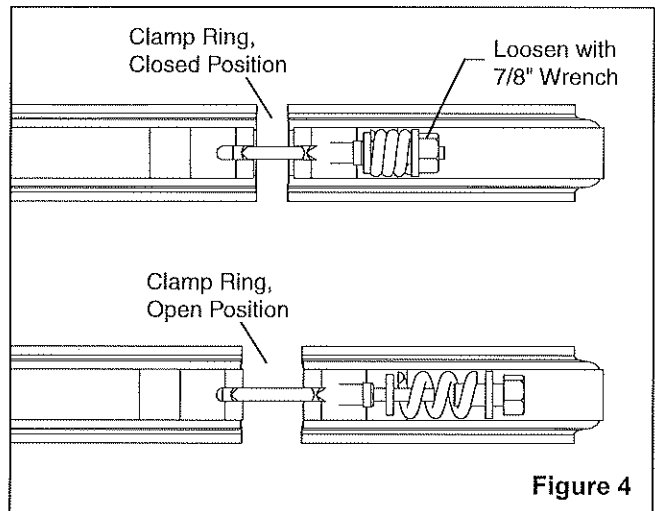

Figure 4



## Installing the Filter Lid and Clamp Ring

### ▲ WARNING



Follow these instructions exactly to prevent the lid from separating from the filter during system start-up or operation. (See *Important Warnings and Safety Instructions*, page ii-iii).

### RECOMMENDED EQUIPMENT:

- Ratchet Wrench
- 7/8" Socket
- Socket Extender (if needed)
- Rubber Mallet

### PROCEDURE:

1. Be sure the O-ring is clean and in position in the lower tank half. Press the Clean and Clear® Plus Cartridge Filter lid onto the lower half so the O-ring fits in between the tank halves.
2. Hold the ends of the clamp ring apart and place over both upper and lower tank flanges. Bring the ends of the filter clamp together.
3. Insert the T-bolt through the other side of the clamp and hold together.
4. Place the small washer onto the T-bolt.
5. Place the spring, large washer and barrel nut onto the T-bolt and tighten the nut by hand. Be sure the clamp ring fits easily on the tank flanges.
6. After tightening by hand:
  - a. Use a 7/8 in. wrench (ratchet wrench recommended) to tighten further.
  - b. Tap around the outside of the clamp ring with a rubber mallet (or similar tool) multiple times around the entire clamp to fit the clamp properly.
  - c. Continue to tighten until the spring coils touch.
  - d. Tap around the entire clamp again and verify the spring coils remain touching. If not, continue to tighten the nut.

**Note:** The clamp is installed correctly only when the spring coils remain touching after tapping the clamp (See Figure 5).

7. Close the waste drain plug at the bottom of the filter.
8. Follow **Start-Up Instructions** exactly (see page 6).

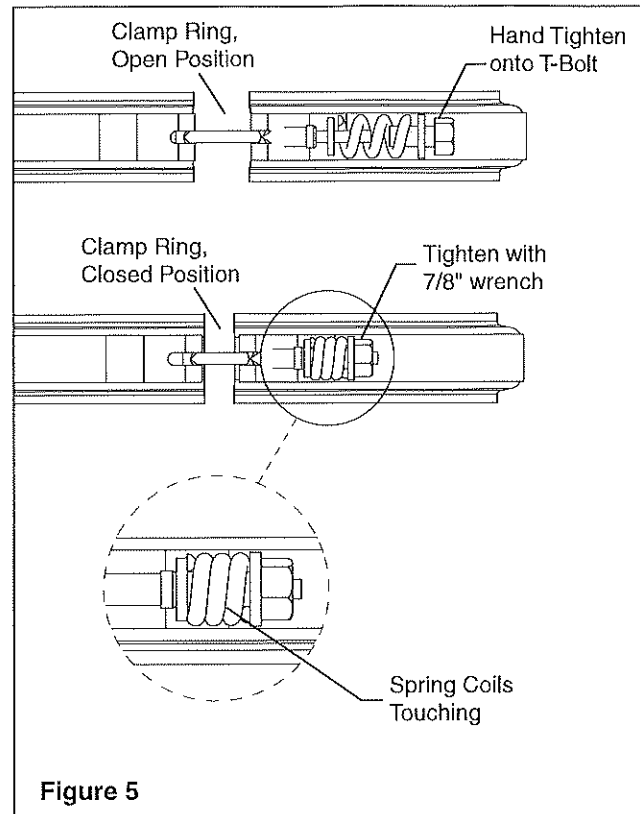

Figure 5

**Note:** Check the spring coils at least once a month to ensure proper tension. If spring coils do not touch then **shut off pump and relieve pressure** and tighten the nut and tap filter clamp until the coils touch.

### ▲ WARNING



DO NOT tighten the nut or attempt to adjust the clamp ring or lid while the system is turned on or under pressure. This could cause the lid to separate from the filter

## Start-Up Instructions

### ⚠ WARNING



Follow these instructions **exactly** to prevent the lid from separating from the filter during system start-up or operation. (See *Important Warnings and Safety Instructions*, page ii-iii).

1. Be sure the **spring on the clamp ring is fully compressed, with coils touching.**
2. Open the High Flow™ Manual Air Relief Valve by turning the valve cover assembly a quarter turn counter-clockwise, until it snaps into the full open position. See **Figure 6**.
3. Stand clear of the filter tank, then start the pump.
4. Watch for proper operation. The system is not working properly if:
  - a. The pressure gauge indicates pressure before water out-flow appears.
  - b. A solid stream of water does not appear within 30 seconds after the pump's inlet basket fills with water.
  - c. Water leaks from where the two halves of the filter come together.

If any of these conditions exist, **shut off the pump immediately**. Open the manual air relief valve to relieve pressure and clean the valve (see *Cleaning the Manual Air Relief Valve*, page 7). If the problem persists, call Pentair Technical Service at (800) 831-7133 for assistance.

5. After a steady stream of water appears, close the manual air relief valve by turning the valve cover assembly a quarter turn clockwise.
6. The first time the system is started up, fill out Table 1 on page 1 and the corresponding label on the equipment:
  - a. Record the "Original Starting Pressure"
  - b. Fill in the pressure at which to clean the filter (8-10 psi higher than the "Original Starting Pressure").
  - c. If the system includes a variable speed pump, record "Original Pump RPM".

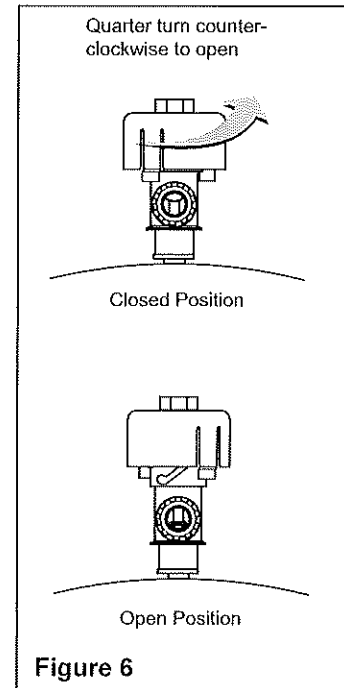

## MAINTENANCE

### Maintaining the Pressure Gauge

The pressure gauge is the primary indicator of how the system is operating, so correct functioning is critical. Replace the pressure gauge (Pentair P/N 190058) if it does not meet the requirements below:

1. Pressure gauge should go to zero (0) when the system is turned off and pressure is relieved.
2. Pressure gauge should indicate pressure when the system is operating.
3. The pressure gauge should be readable and not damaged in anyway

### Cleaning the Manual Air Relief Valve

#### RECOMMENDED EQUIPMENT:

- 5/16" Drill Bit (to check air passage)
- Silicone-based Lubricant (if needed)

#### PROCEDURE:

1. Shut off pump and relieve pressure.
  - a. Turn the pump OFF and shut OFF any automatic controls (e.g., timers) and disconnect power to ensure that the system is not inadvertently started during maintenance.
  - b. Open the manual air relief valve by turning the valve cover assembly a quarter turn counter-clockwise until it snaps into the full open position.
  - c. Stand clear of the filter and wait until all pressure is relieved. **Pressure gauge must read zero (0 psi).**
2. With the relief valve attached to the Clean and Clear® Plus Cartridge Filter tank, pull out the locking tabs and unlock the valve stem and cover assembly from the valve body with a counter-clockwise turn, see **Figure 7**.
3. Pull the valve stem and cover assembly straight up and away from the valve body.
4. Clean and check the valve stem and body:
  - a. Clean off any debris.
  - b. Verify that the filter tank's air passage is open by inserting a 5/16" drill bit through the valve body.
  - c. Verify that the valve stem O-rings are in good condition, properly positioned, and lubricated with a silicone-base lubricant.

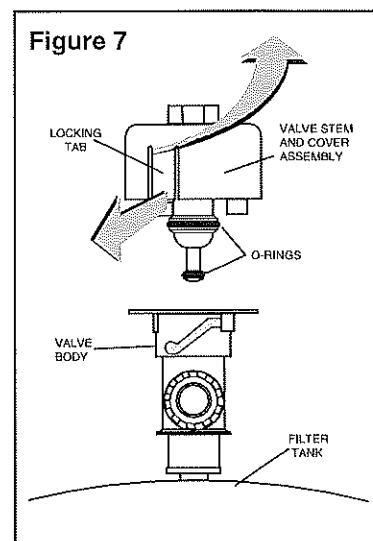

If needed, use only a PTFE or silicone-base lubricant on the O-rings. Use of petroleum based products on O-rings will damage the equipment.

5. Reinstall the valve stem and cover assembly with a downward and clockwise motion until it snaps into position.

## When to Clean Your Filter

Proper operation can prevent avoidable repairs and maintenance.

Use the pressure gauge to determine when to clean your Clean and Clear® Plus Cartridge Filter for proper operation. The pressure reading increases as dirt is filtered from your pool. This buildup of pressure will vary due to different bathing loads, temperature, environmental conditions, etc.

### ⚠ WARNING



Clean your filter when pressure reads between 8-10 psi higher than the "Original Starting Pressure" recorded in Table 1 (page 1), or when significant reduction in flow is noticed.

**Note:** When using a variable speed pump the "Original Starting Pressure" will be dependent on the pump speed (RPM) when recording the original operating pressure.

## Cleaning the Filter Cartridges

1. Follow *Opening the Filter* (page 4) exactly.
2. Remove hair and lint strainer pot lid from the pump and clean basket. Replace strainer basket and secure strainer pot lid.
3. Remove the compression spring and spring adapter by pulling them straight up.
4. Separate the top manifold from the filter's cartridges and lay the manifold to the side. See **Figure 8**.
5. Carefully remove each cartridge element separately.
6. Using a garden hose with a straight flow nozzle, wash down the entire filter element. Wash from the top down, holding the nozzle at a 45-degree angle to the cartridge (See **Figure 9**). Pay special attention to the area between pleats.
7. For cartridges used in pools or spas where high levels of perspiration, suntan lotions and other oils are present:
  - a. Soak the cartridge for at least one hour (overnight is most effective) in one of the following:
    - A commercial filter cleaner

### ⚠ WARNING

Heed all manufacturers' instructions and warnings when using polyhexamethylene biguanide sanitizers or other cartridge filter cleaner solutions.

- One cup trisodium phosphate (TSP) to five gallons of water
  - One cup dishwasher detergent to five gallons of water
- b. Rinse the cartridge to remove oils and cleaning solution.

### ⚠ CAUTION

Failure to remove all oils and cleaning solutions before acid soaking will result in permanent restriction of water flow through the filter and will cause premature cartridge failure.

8. Direct the water spray to wash out the inside of the tank body and bottom manifold. Water and debris will drain out through the open drain plug.
9. Check gasket around outer lip of bottom plate. Gasket must be firmly and evenly set around the entirety of the outer lip.
10. Place bottom manifold, four (4) cartridges and top manifold in place. Make sure the spring and standpipe assembly are retained on the top manifold.
11. Be certain the O-ring is in position in the lower tank half and free of debris.
12. Follow *Installing the Filter Lid and Clamp Ring* exactly (page 5).

**Figure 8**

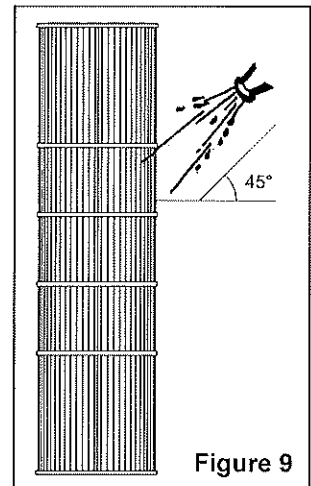
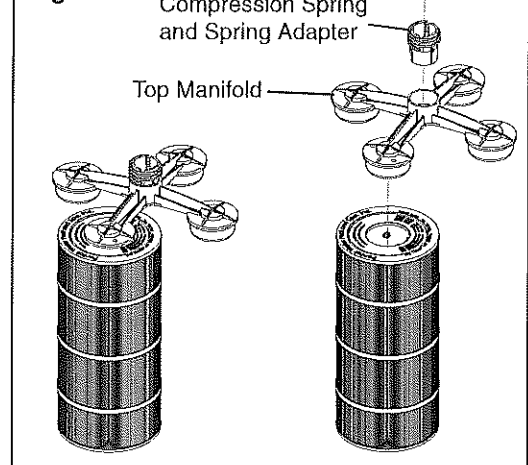

**Figure 9**

## Acid Soaking the Filter Cartridges

After an extended period of operation, it may be necessary to soak the cartridges in an acid solution. Acid soaking will remove algae, calcium carbonate, iron and other mineral build-ups from the cartridges. If not removed, these mineral deposits can lead to the restriction of water flow through the Clean and Clear® Plus Cartridge Filter and can impede efficient operation of the equipment.

### ⚠ WARNING

Muriatic acid is corrosive and can lead to inflammation or burns to body tissue.



ALWAYS wear rubber gloves, safety glasses and an N-95 dust mask when handling acid to prevent serious bodily injury.

### ⚠ CAUTION

To prevent degradation of the acid by UV light, store muriatic acid in an opaque container and away from direct sunlight.

### RECOMMENDED EQUIPMENT:

- Large Plastic Container
- Garden Hose with a Straight Flow Nozzle
- Muriatic Acid (stored in opaque container)
- Rubber Gloves
- Safety Glasses
- N-95 Dust Mask

### PROCEDURE:

1. Remove all oils and cleaning solutions from the cartridges.

### ⚠ CAUTION

Acid soaking without performing this step will result in permanent restriction of water flow through the filter and premature cartridge failure.

2. Put on protective equipment - rubber gloves, safety glasses and N-95 dust mask.
3. In a large plastic container, create a solution of one part muriatic acid to twenty parts water. See **Figure 10**.

### ⚠ WARNING

Introduce the muriatic acid as close to the water's surface as possible. This will minimize splash and reduce the risk of user contact with the acid.

4. Gently place the bottom of the cartridges into the acid solution. Allow the cartridges to soak in the solution for 10 minutes, or until bubbling stops.
5. Turn the cartridges over, placing the top halves into the solution. Allow the top halves of the cartridges to soak for 10 minutes, or until bubbling stops.
4. Remove the cartridges from the acid solution.
5. Using a garden hose with a straight flow nozzle, thoroughly wash down the entire filter element. Wash from the top down, holding the nozzle at a 45-degree angle to the cartridge. See **Figure 9**, on page 8.
6. Reinstall the cartridges and dispose of the acid solution in accordance with local regulations.

**Figure 10**

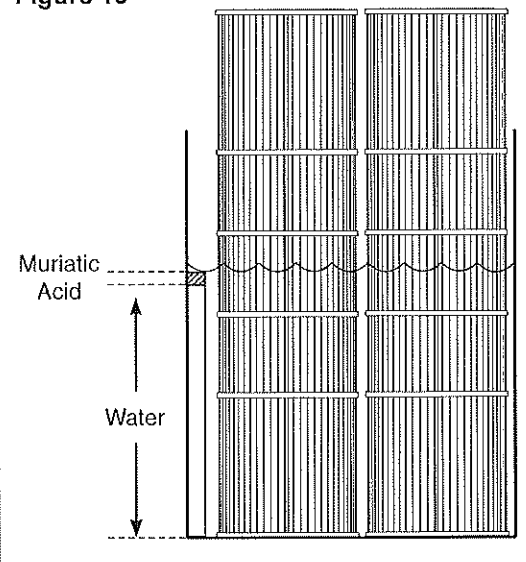

## Replacing Filter Cartridges

Filter cartridge element life will vary with pool conditions such as bather load, wind, dust, etc. You can expect an average cartridge life of three (3) years under normal conditions.

### To replace filter cartridges:

1. Follow *Opening the Filter* exactly (page 4).
2. Remove the compression spring and spring adapter by pulling them straight up. Once the spring and spring adapter have been removed, separate the top manifold from the filter cartridges and lay the manifold to the side. See **Figure 6**.
2. Carefully remove each cartridge element separately.
3. Check gasket around outer lip of bottom plate. Gasket must be firmly and evenly set around the entirety of the outer lip.
4. Install the replacement cartridges onto the bottom manifold. Reinstall the top manifold on to the new cartridges.

**Note:** Be sure the spring and standpipe assembly are retained on the top manifold.

5. Follow *Installing the Filter Lid and Clamp Ring* exactly (page 5).

## TROUBLESHOOTING

### 1. AIR ENTERING THE SYSTEM.

Air entering your Clean and Clear® Plus Cartridge Filter can cause lid separation. Correct any conditions in your filtration system that allow air to enter the system.

#### **WARNING**



Air entering the system can cause the lid to separate from the filter. If the below symptoms are observed, do not attempt to remove or tighten the clamping system or perform any other servicing until you have shut off pump and relieved all air and pressure in accordance with the Opening the Filter instructions (page 4). (See Important Warnings and Safety Instructions, page ii-iii)

#### **Symptoms:**

- Low water level in pool or spa - skimmer starving for water with pump running.
- Air bubbles or low water level in pump hair and lint pot
- Air bubbles coming out of water return lines into pool or spa with pump running
- Air is discharged from the air/pressure relief valve on top of the filter when the valve is opened with the pump running.

#### **Potential Causes and Solutions:**

- Low water level: *Add water to pool or spa.*
- Clogged skimmer basket: *Unclog.*
- Damaged or leaking components (e.g., split suction cleaner hose, leak in pump hair and lint pot lid, or leak in pump suction line): *Repair or replace component.*

### 2. SHORT FILTER CYCLES BETWEEN CLEANING.

Until the water initially put into the pool has been completely filtered, short filter cycles in between cleanings are normal. In most cases pool owners are dismayed by the undesirable color and appearance of water in a newly filled pool. Plaster dust can be responsible for short filter cycles, requiring frequent cleaning.

### 3. PRESSURE DROP ON GAUGE.

If pressure drops on gauge, check skimmer basket and pump basket first for debris. If the baskets are clean, there is likely a problem with the pump. Refer to pump manual for pump troubleshooting.

# TECHNICAL DATA

## Flow Rates

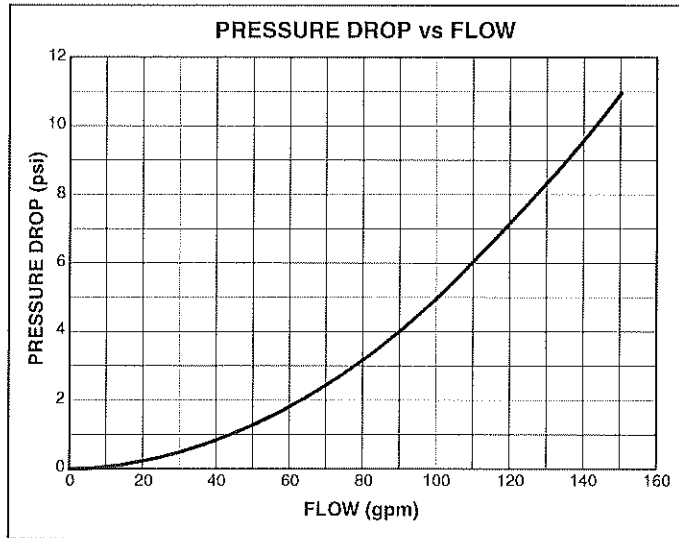

Clean and Clear® Plus Cartridge Filters						
Recommended Flow Rate						
Model #	Filter Area (Sq. Ft.)	Vertical Clearance*	Flow Rate (GPM)	Turnover Capacity (Gallons)		
				6 Hours	8 Hours	12 Hours
CCP240	240	56 in.	90	32,400	43,200	64,800
CCP320	320	62 in.	120	43,200	57,600	86,400
CCP420	420	68 in.	150	54,000	72,000	108,000
CCP520	520	74 in.	150	54,000	72,000	108,000

NOTE: Actual system flow will depend on plumbing size and other system components.  
 \* Required Clearance to remove filter elements and lid.

## Dimensional Drawings

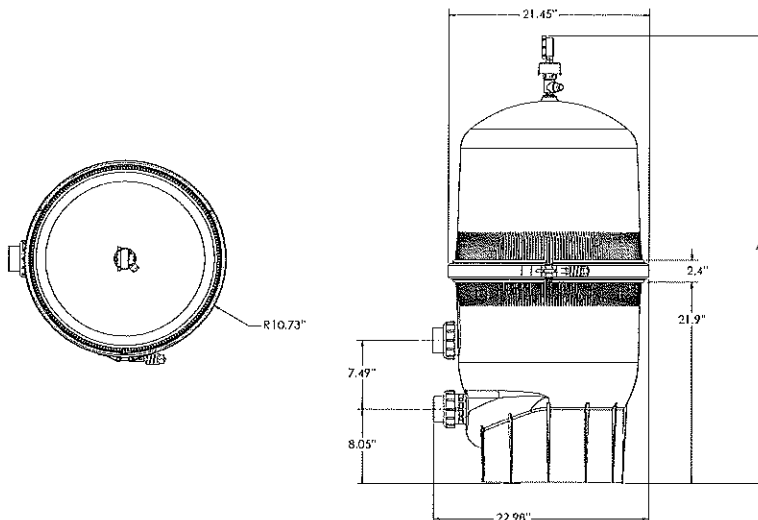

MODEL	DIM "A"
CCP 240	37"
CCP 320	43"
CCP 420	49"
CCP 520	56"



# REPLACEMENT PARTS

## Illustrated Parts View

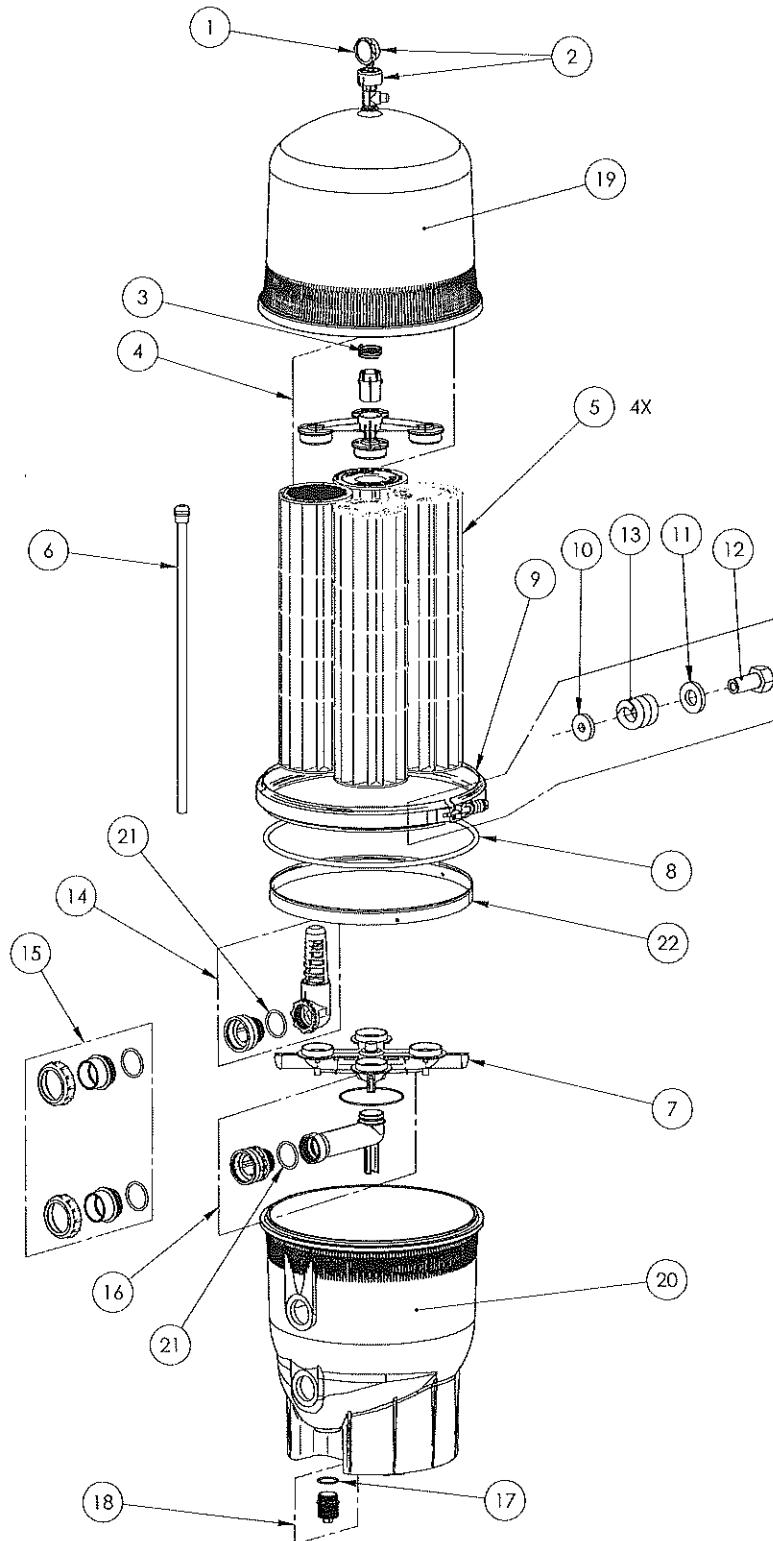

## Clean and Clear® Plus Cartridge Filter Parts List

### Replacement Parts

Item No.	Part No.	Description
1	190058	Pressure Gauge, with Indicator
2	98209800	High Flow Manual Air Relief Valve (HFMARV)
3	178616	Compression Spring
4	170026	Top Manifold, 240 C&C Plus
4	170027	Top Manifold, 320/420/520 C&C Plus
5	R173572	Cartridge Element, 240 C&C Plus, 4 req.
5	R174573	Cartridge Element, 320 C&C Plus, 4 req.
5	R173576	Cartridge Element, 420 C&C Plus, 4 req.
5	R173578	Cartridge element, 520 C&C Plus, 4 req.
6	170030	Air Bleed Tube Assy., 240 C&C Plus
6	170029	Air Bleed Tube Assy., 320 C&C Plus
6	170028	Air Bleed Tube Assy., 420 C&C Plus
6	178583	Air Bleed Tube Assy., 520 C&C Plus
7	170040	Bottom Manifold
8	39010200	O-ring, Tank Clamp (.470 O.D.)
9	190003	Clamp Band Replacement Kit
10	195610	Clamp Washer, Small I.D.
11	195611	Clamp Washer, Large I.D.
12	194997	Clamp Nut
13	195612	Clamp Spring, 4-Coil
14	190039	Baffle Assy., C&C Plus
15	98960311	Union Kit, Black
15	271096	2" Valve Adapter Kit, 1 ½ in. x 2 in. (set), White
15	270004	2" Valve Adapter Kit, 1 ½ in. x 2 in. (set), Black
15	274426Z	2 x 2.5" Valve Adapter Kit,

Item No.	Part No.	Description
16	170036	Pipe Assy. Outlet, C&C Plus
17	190143	O-ring, Drain
18	190030	Drain Plug, without O-Ring
19	170023	Tank, Lid Assy., 240 C&C Plus
19	170024	Tank, Lid Assy., 320 C&C Plus
19	178581	Tank, Lid Assy., 420 C&C Plus
19	178582	Tank, Lid Assy., 520 C&C Plus
20	178578	Tank, Bottom Assy. (Includes Items 7, 14, 16 and 18)
21	86006900	O-ring
22	195339	Ring, Steel Back-up
-	192019	Drain Plug Wrench
-	171013	Label Kit w/ Air Relief, 240 C&C Plus
-	171014	Label Kit w/ Air Relief, 320/420/520 C&C Plus
-	190106Z	Air Bleed Screen Cap

(-) Not Shown





1620 HAWKINS AVE., SANFORD, NC 27330 • (919) 566-8000  
10951 WEST LOS ANGELES AVE., MOORPARK, CA 93021 • (805) 553-5000

[WWW.PENTAIRPOOL.COM](http://WWW.PENTAIRPOOL.COM)

All Pentair trademarks and logos are owned by Pentair or one of its global affiliates. Clean & Clear<sup>®</sup>, High Flow<sup>™</sup> and Eco Select<sup>®</sup> are trademarks and/or registered trademarks of Pentair Water Pool and Spa, Inc. and/or its affiliated companies in the United States and/or other countries. Unless expressly noted, names and brands of third parties that may be used in this document are not used to indicate an affiliation or endorsement between the owners of these names and brands and Pentair Water Pool and Spa, Inc. Those names and brands may be the trademarks or registered trademarks of those third parties. Because we are continuously improving our products and services, Pentair reserves the right to change specifications without prior notice. Pentair is an equal opportunity employer.

© 2017 Pentair Water Pool and Spa, Inc. All rights reserved. This document is subject to change without notice.



P/N 178558 Rev. P 7/6/17