

DualSense D CAN

Sensor for activating and safeguarding automatic sliding doors, including emergency exits, in accordance with EN 16005 and DIN 18650, with CANopen interface in accordance with EN 50325

1	Description	2	4.1	Software configuration	6
1.1	Function	2	4.2	Mechanical settings	8
1.2	Interface	2	5	Operation	10
1.3	Scope of delivery	2	5.1	Commissioning	10
2	Safety instructions	2	5.2	Status display	10
3	Installation	2	5.3	Maintenance	10
3.1	Mounting position	2	6	Faults	10
3.2	Mounting preparation	2	6.1	Tools	11
3.3	Mounting	2	7	Technical data	12
3.4	Connecting to CAN bus	5	8	Contact	13
4	Settings	6			

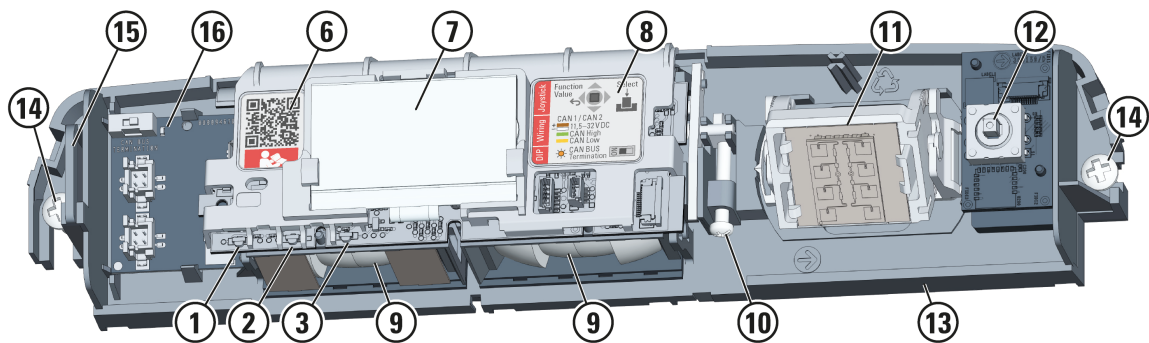
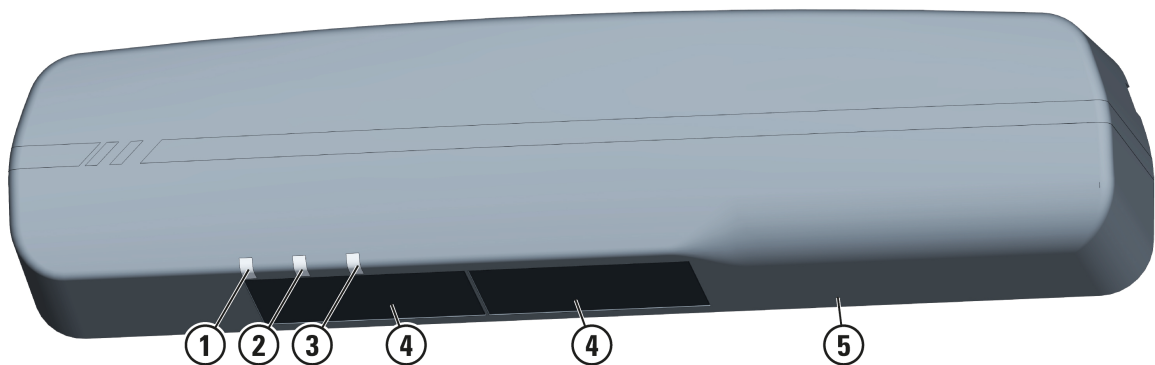

- | | | | |
|----------|---------------------------------|-----------|-----------------------------------|
| 1 | Red LED (active infrared, AIR) | 9 | Optics (4 AIR lenses each) |
| 2 | Green LED (radar) | 10 | AIR angle adjustment |
| 3 | Blue LED (configuration) | 11 | Radar module |
| 4 | Infrared light window (AIR) | 12 | Joystick |
| 5 | Cover | 13 | Support plate |
| 6 | QR link to online documentation | 14 | Fastening clips |
| 7 | Display | 15 | Cable strain relief |
| 8 | Connection label | 16 | CAN bus connections, DIP switches |

1 Description

1.1 Function

The sensor is designed for mounting above an automatic pedestrian door and for connection to the door controller.

To activate the door, a radar field detects the movement of people.

To safeguard the door, an AIR field (active infrared) detects the presence of people.

1.2 Interface

The sensor communicates with the door controller via a bus system using the CANopen protocol according to EN 50325-4 and the safety concept according to IEC 61784-3.

Using the sensor requires a door controller that is specifically configured to interpret the sensor signals. To set up a door controller, please contact:

✉ service@bircher.com ☎ +41 52 687 1366

1.3 Scope of delivery

Standard package contents

- Sensor with cover
- Connection cable, with plug connector on the sensor side
- Cover plates for AIR lenses
- Mounting materials
- Drilling template
- QuickStart guide

Optional accessories

- Rain cover
- Curved adapter
- Ceiling mounting bracket
- Ceiling mounting kit
- CAN connection cable, with plug connector on both sides

2 Safety instructions



Read the operating instructions carefully before commissioning the device. Keep the instructions for future use.

Intended use

The manufacturer is only liable for products used as intended. Only use this product for the following purpose:

Sensor for activating and safeguarding automatic sliding doors, including emergency exits, in accordance with EN 16005 and DIN 18650, with CANopen interface in accordance with EN 50325

Personnel qualification

Only trained and qualified personnel may install and commission the device.

The installer is responsible for installing the device and the connected system in accordance with the regulations and standards.

General safety instructions

It is the responsibility of the equipment installer to carry out a risk assessment and to install the system, in compliance with applicable regulations and safety standards.

If installation according to EN 61558 is required, the detector may only be operated using safety extra-low voltages (SELV) with safe electrical isolation.

The cables must be protected against mechanical damage.

3 Installation

3.1 Mounting position

Door requirements for the sensor:

- Always position a sensor above the main closing edge.

Requirements for the environment:

- Surface must be stable, vibration-proof and grounded.
- The sensor requires an unobstructed field of view to detect objects.
- Avoid proximity to fluorescent lamps.
- Avoid pointing strong streams of air (currents of warm air, ventilation systems) at the sensor.
- Shield the sensor against extreme weather conditions, e.g. with a rain cover, canopy or installation under the door lintel.

Sensor distance to door level:

- Max. 300 mm as standard, see section "**Set the AIR inclination angle**".
- A reduced distance is recommended for mounting with the ceiling mounting kit, see section "**Ceiling mounting kit**".

3.2 Mounting preparation

- 1) Disconnect the power supply to the door controller.
- 2) Specify the mounting position.
- 3) Lay the connection cable. Ensure that the cable is routed so that it is free of electromagnetic interference. Avoid e.g. parallel routing of the cables for the sensor and door drive.

The cable end with plug connector must be laid towards the sensor.

Lay cables with plug connectors at both ends between sensors connected in series (optional accessory).

- 4) Remove the cover from the sensor.
- 5) Prepare the **Mechanical settings** according to the installation situation:
 - To mount for a door in a narrow aisle, turn the radar module.
 - To limit the AIR field, cover lenses.
 - Set the AIR inclination angle according to the table.

3.3 Mounting

The sensor is attached to or above the door frame as standard.

The sensor can also be attached in the door frame or under the ceiling with the corresponding accessories, see **3.3.1 "Ceiling mounting with angle"**

Optionally, installation in a suspended ceiling is possible, see **3.3.2 "Ceiling mounting kit"**

- 1) Glue the drilling template onto the intended location. Pull the edge of the drilling template (marked gray in the picture) away from the gluing point.

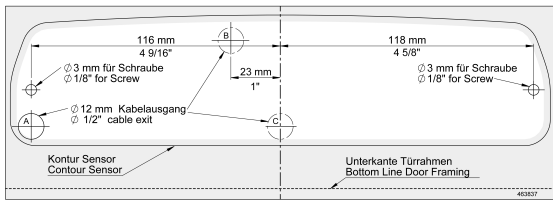

- 2) Make two core holes \varnothing 2.0 to 2.5 mm in the door frame at mounting points. Alternatively, place dowels above the frame.
- 3) Drill a cable aperture \varnothing 12 mm in the door frame at position A, B or C.
- 4) Position the following optional accessories on the screw holes:

Curved adapter

to level the mounting surface on a revolving door

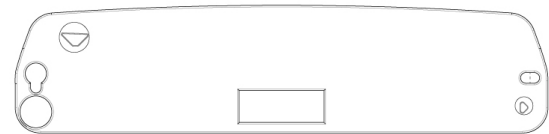
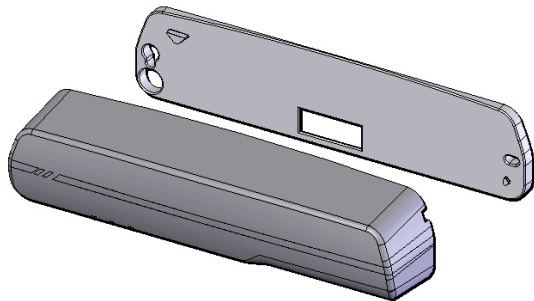

Rain cover

to protect sensors on the external facade

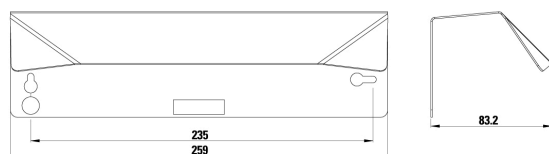
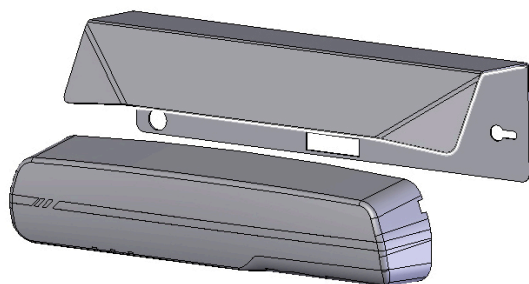

- 5) Position the connection cable.
To connect the sensor in series, position both connection cables.

- 6) Screw the support plate of the sensor to the mounting points.

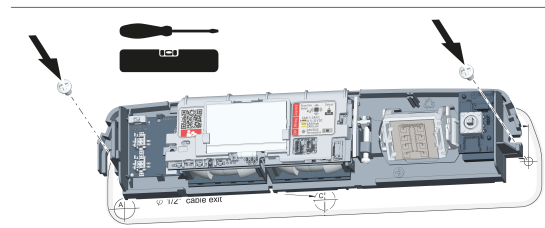

3.3.1 Ceiling mounting with angle

To mount the detector on the ceiling or in the lintel, use the angle profile (optional accessory).

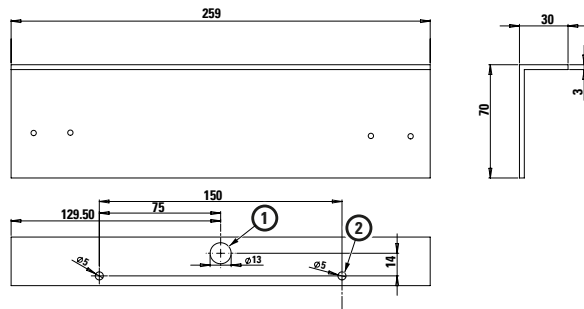
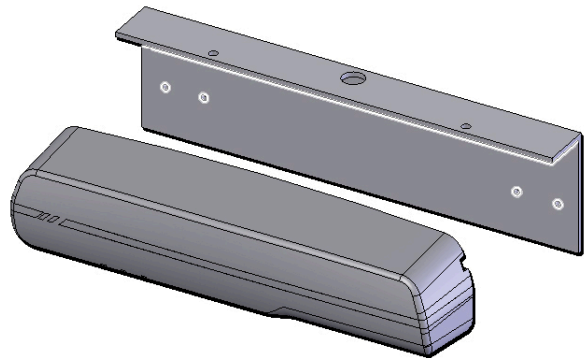

- 1 Cable aperture
- 2 Hole for screw

Use the angle profile instead of the drilling template.

- 1) With the help of the angle profile, mark the positions of the cable outlet (1) and the two screws (2).
- 2) Drill a cable aperture \varnothing 12 mm and, if necessary, screw holes \varnothing 3 mm.
- 3) Attach the angle profile.
- 4) Position the cable.
- 5) Screw the support plate of the sensor to the mounting points.

3.3.2 Ceiling mounting kit

To integrate the detector into the ceiling cladding, use the integration kit (optional accessory).

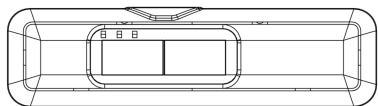
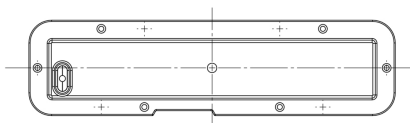
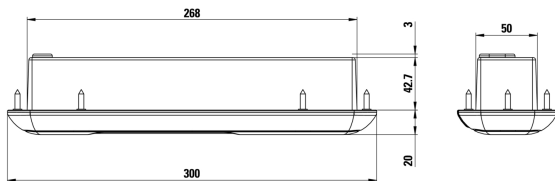
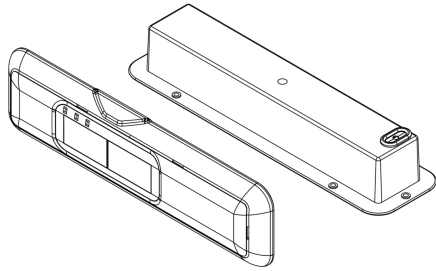

NOTE

Configuration-friendly mounting position

The detector is removed from the installation housing for configuration. An AIR inclination angle of $\geq 0^\circ$ must be set to prevent the sensor display from hitting the housing wall when it is reinserted. AIR angle values below 0° must be readjusted after each configuration.

- To avoid an AIR inclination angle below 0° , limit the mounting distance R:

Mounting height H (mm)	Distance R (mm)
≤ 2200	≤ 200
≤ 3000	≤ 250

For details, see section **"Set the AIR inclination angle"**

Do **not** use: Cover and drilling template from the standard scope of delivery of the detector.

- 1) Glue the drilling template from the ceiling mounting kit onto the mounting site.

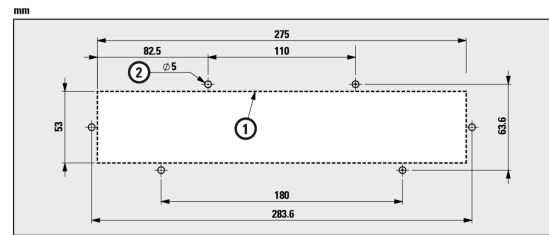

- 2) Cut a recess in the ceiling cladding along line (1).
- 3) Center-punch the positions for self-drilling screws or drill screw holes $\varnothing 3$ mm.
- 4) Remove the mounting template.
- 5) Pull the connection cable through the opening in the ceiling mounting kit.

For sensors connected in series, pull both cables through the opening.

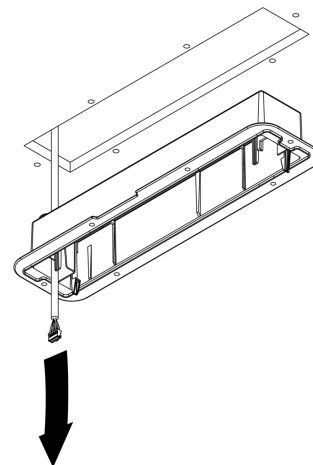

- 6) Insert the mounting housing into the recess and screw the flange to the ceiling.

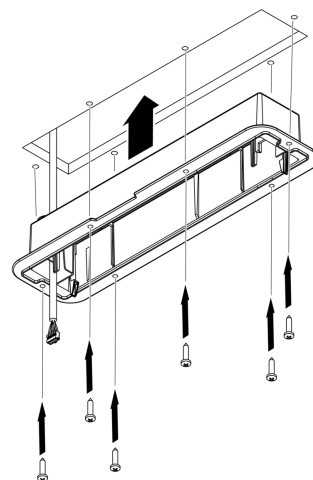

- 7) Connect the sensor to the connection cable and adjust the sensor settings, see section **Settings**. To align the AIR field, slide the detector into the mounting housing until it clicks into place.

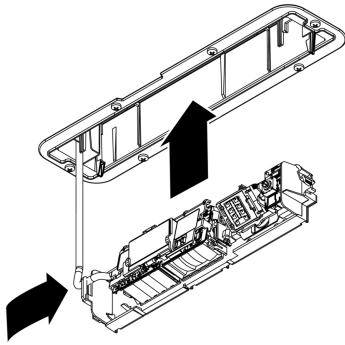

To close the ceiling mounting kit, press the supplied cover onto the flange of the mounting housing. The edge of the cover snaps into place on the flange.

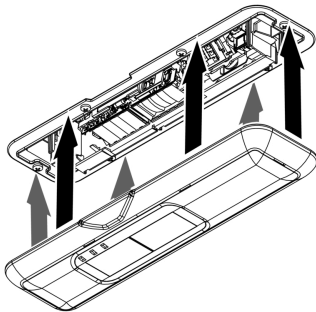

To open the cover, lever the edges out of the catch hooks.

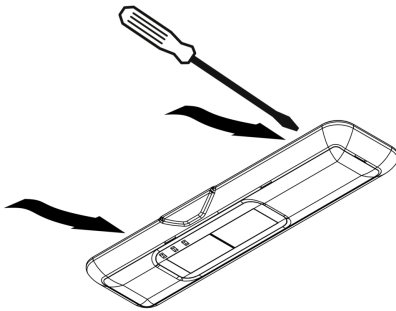

You must open the cover for the following purposes:

- Cleaning the infrared windows
- Changing the detector settings

3.4 Connecting to CAN bus

Connecting sensors

Connect the sensors that are part of the door system to the door controller in series:

- 1) Plug the plug connector of the laid cables into one of the two CAN bus slots on the sensor.
- 2) The last sensor in the series (Z) is connected to only one cable. Activate the termination resistor here by setting the dip switch on this sensor to **ON**. The indicator light on the DIP switch now lights up.

For all other sensors (A, B), the DIP switch must be set to **OFF**.

- 3) Connect the cable end without the plug connector to the door controller on the first device in the series (A) as indicated below.

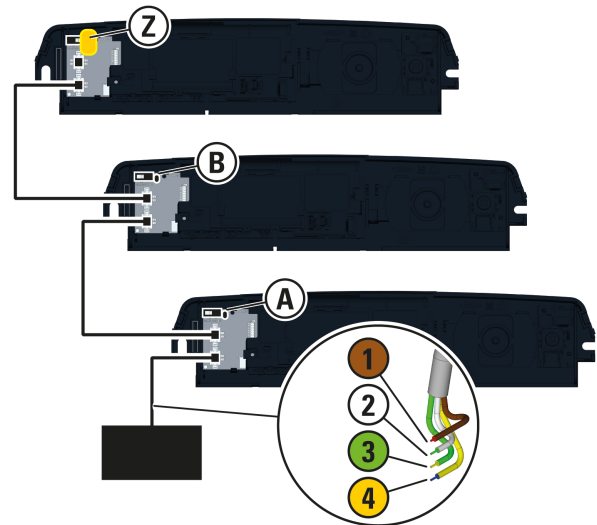

	1 brown	+	11.5 – 32 V DC
	2 White	-	
	3 Green		CAN H (high)
	4 yellow		CAN L (low)

Locating sensors on the bus

- 1) Switch on the power supply to the door controller.
- 2) Connect to the door controller user interface.
- 3) Use LSS (Layer Setting Service) to make the following settings on the sensors on the bus.

The network address (node ID)

must be changed. A unique address is required for each device.

Factory setting	255
Required address	2 to 127

The bit rate

can be changed. A lower bit rate is usually more robust against electromagnetic environmental influences.

Factory setting	125 kbit/s
Alternative	250 kbit/s

- 4) For each sensor type used on the bus, load an EDS (Electronic Data Sheet) file from the manufacturer's homepage into the PLC. Assign the appropriate EDS to the sensors.

You can now configure the sensors on the respective sensor display or centrally via the user interface of the door controller.

4 Settings

4.1 Software configuration

4.1.1 Operate display and joystick

The current detector status is shown on the display. **AIR** displays a presence detection. **Radar** indicates motion detection. A fault code is shown in the event of faults. To configure the detector, press the joystick.

Joystick action in the status view



The display switches to the menu view. The menu view lists the configurable parameters, categorizing them into menu groups. Besides the parameter name, the currently set value is also shown. Use the menu view to navigate between the parameters.

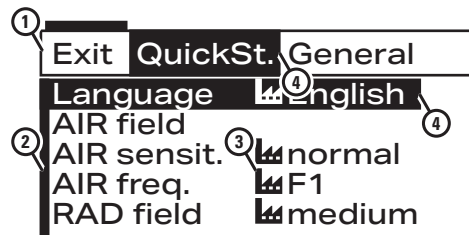

Menu view

- 1 Menu group
- 2 Parameter
- 3 Currently set value
- 4 Selection in the navigation

Joystick action in the menu view

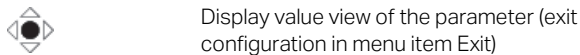
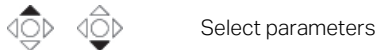
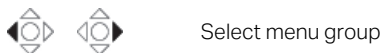

To change the value for the selected parameter, press the joystick. The display switches to the value view. The value view lists the configurable values of a parameter. Select the relevant value and/or return to the menu view.

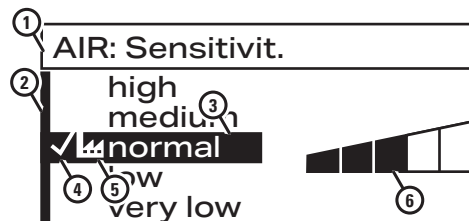

Value view

- 1 Displayed parameter
- 2 Configurable values
- 3 Selected value
- 4 Selection of the currently set value
- 5 Selection of the factory setting
- 6 Visual explanation of the selected value

Joystick action in the value view



Joystick action in the value view

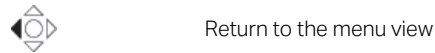

You can close the configuration in the menu by selecting **Exit**. Alternatively, the display switches to the status view after a time-out.

Time-out

1 minute not actuated	Configuration closes automatically
3 minutes not actuated	Password protection active (if set)

4.1.2 Configure parameter

Initial installation

- 1) Press the joystick.
- 2) Follow the QuickStart menu shown on the display. Configure the parameters and the mechanical settings as described in the following. Close the QuickStart menu by restarting the detector (menu item **Start**).
- 3) For doors in escape and emergency routes: If you use the frequency output, go to **Radar** in the menu and select the value **Frequency** for the parameter **Output RAD**.
- 4) Test the door system. If necessary, optimize other parameters.
- 5) If desired, protect the configuration in the menu group **General** with a password.
- 6) Finish configuration in the menu group **Exit**.

i NOTE

Default settings

The detector starts with the default settings. Alternative default settings can be selected in the **General** menu group. The default settings take into account typical features of certain applications:

footpath situation, wind screen, retirement home, especially high, wide or narrow doors.

Attention! Selecting default settings overwrites the set values for all parameters.

i NOTE

QuickStart

The QuickStart menu guides you through the basic steps of the initial installation. It also indicates when mechanical settings need to be made.

Overview of menu groups

Parameter name	Notes on selecting a suitable value
----------------	-------------------------------------

QuickStart

Select your menu language during initialization.

AIR field	Configure the mechanical settings as described under Set presence detection .
-----------	--

AIR sensitivity	Configuring presence detection: Make the following selection for a mounting height <ul style="list-style-type: none"> – above 3.0 m high – above 2.6 m medium – above 2.2 m normal The settings low and very low are suitable for special floor conditions. If installation in accordance with standard EN 18650 is required, select high . Test presence detection with a test specimen. Adjust the setting until the test specimen is always reliably recognized.
AIR frequency	Important for series circuits: To avoid conflicts due to overlapping infrared fields, select different frequency settings for adjacent detectors.
Radar field	Configuring motion detection: Set a size for the radar field so that the door opens at the desired time. If necessary, adjust the position of the radar module mechanically, see Set motion detection .
Start	Finish initialization by restarting the detector and teaching in presence detection (AIR).

General

Language	Menu language setting
Outputs	Separate: Only radar detection opens the door, Combined: Radar and AIR detection open the door.
Default settings	Typical settings for specific applications. Attention: All parameters will be overwritten. Test the settings and adjust the values as needed.
Reset	Restart teaches the detector in again. Factory setting deletes all manual settings, including password.
Password	Dialog for setting a password consisting of 4 digits. At 0000, the password protection is inactive (factory setting). For any other combination of digits, the password is requested when the configuration menu is started. The menu is locked again 3 minutes after the configuration is finished. If the password is lost, disconnect the detector from the power source. After reconnection, the configuration is open for 1 minute to set a new password.
LED	Configuring the LED display: By factory default, the green status LED shows radar detections, while the red LED shows AIR detections. For details, see section 5.2 "Status display" You can switch off the LEDs. You can switch on all the LEDs to display an additional blue flashing signal while the sensor is being configured via the CAN bus.

Radar

Field	Size of the area for motion detection: Test the relevant setting.
Direction recognition	The Forward setting only detects movement towards the door, Both also away from the door.
Cross traffic	The Optimized setting reduces the response to cross traffic.

Filter	Turning on the filter can reduce interference from unwanted ambient effects. The filter also lowers the sensitivity of the radar. Test this setting if necessary.
Output RADAR	Settings for Radar output, solid state relay, max. 34 V DC, max. 40 mA: active (NO): Normally open contact, closes on detection. passive (NC): Normally closed contact, opens on detection. Frequency: Contact normally opens and closes with 100 Hz, stops on detection (suitable for door in escape route, see Electrical connection). Voltage output for radar does not require any specific settings.

AIR

Sensitivity	See QuickStart .
Presence	The selected time determines the time after which a stationary object is ignored and the door is permitted to close.



ATTENTION

Standard-compliant setting:

- min. 30 s acc. to EN 16005
- min. 60 s acc. to DIN 18650

Output AIR	The switching logic active (NO) closes, passive (NC) opens the contact when the safety-relevant function is triggered. The slave (NO) and slave (NC) settings are required for series circuits.
Break	The safety-relevant function can be switched off for 15 minutes for maintenance work. The red LED flashes during the break. Attention! This function can only be activated in the CAN network via the door controller, not using the joystick.
Frequency	See QuickStart .

Info

Information on the status of the device for troubleshooting. For more details, see section **6.1 "Tools"**

Log	Messages and error codes
AIR sign.	AIR signal level for analysis purposes in case of complicated ambient conditions.
Config ID	Currently saved detector configuration as a QR code, which you can take a picture of for support purposes.
Op. hours	Operating hours counter
SW	Software version

CAN

Information on the status of the device for troubleshooting.

Position	Assigning a sensor position in the door system that facilitates identification of the device in the user interface of the door controller
Node ID	Displays the network address of the sensor on the bus
Bit rate	Displays the transmission rate used on the bus

NMT status	Indicates whether the sensor is currently being configured, is ready for operation or has been stopped
CAN bus	Indicates whether the cable connections in the bus are undamaged

Exit



Exit configuration

4.2 Mechanical settings

4.2.1 Set motion detection

For motion detection, the detector contains a radar module. The module generates a conical radar field with an oval cross-section. The radar module setting determines the position where the field recognizes movement of people.

Rotate radar module

A short, wide radar field is generated as standard. By rotating the radar module, you can generate a long, narrow field, e.g. for installation for a door in a narrow hallway.

Wide radar field

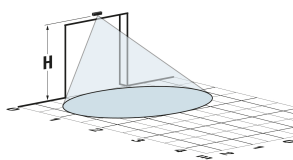
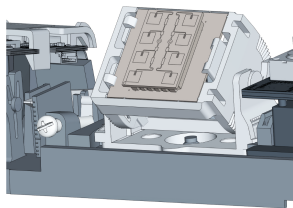

max. 4.00 × 2.00 m

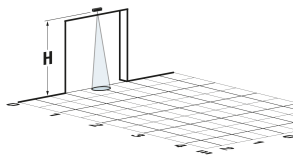

min. 1.90 × 1.00 m

Narrow radar field

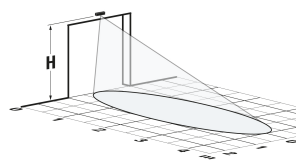
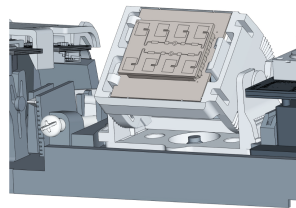

max. 2.00 × 4.00 m

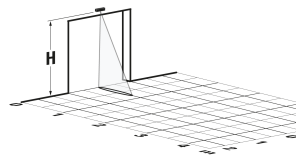

min. 1.00 × 4.00 m

To adjust the field dimensions, see section [4.1.2 "Configure parameter"](#)

To generate a narrow radar field:

- 1) Remove the module on the right from the locking hook.

- 2) Rotate the module by 90°.
- 3) Press the module back into the locking hook.

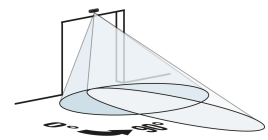
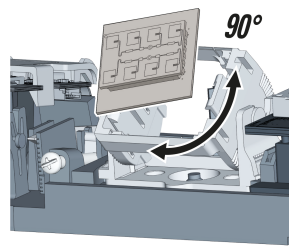

Align the radar module

The radar module can be manually tilted at an angle of 0 to 90° and swiveled 20° to either side.

- 1) Adjust the swivel angle so that the radar module is aligned to the path in front of the door.
- 2) Adjust the inclination angle so that the movement of people is detected at the desired distance from the door.

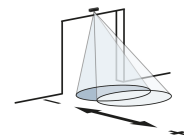
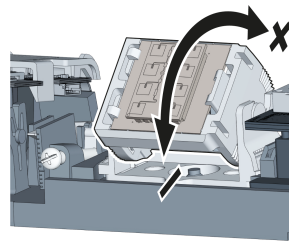
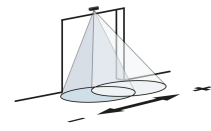
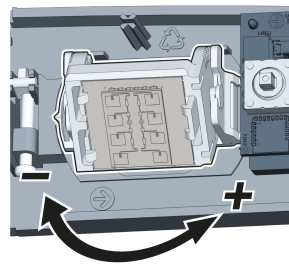

4.2.2 Set presence detection

The detector is equipped with a safety device. To prevent injuries caused by automatic door movements, the detector detects the presence of people with an AIR field (active infrared light). Optics with 4 lenses creates an AIR light field made of 4 segments (A to D).

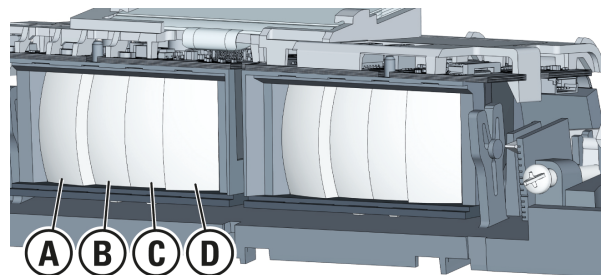

The size of the AIR field on the floor depends on the mounting height of the detector (see drawing with example values for the height $H = 220$ cm).

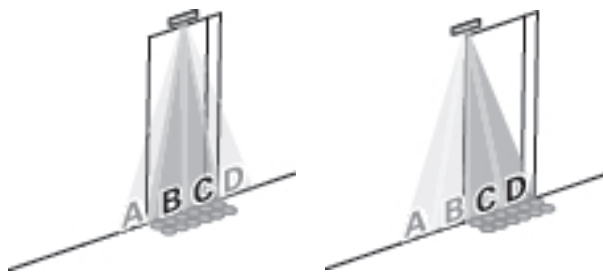
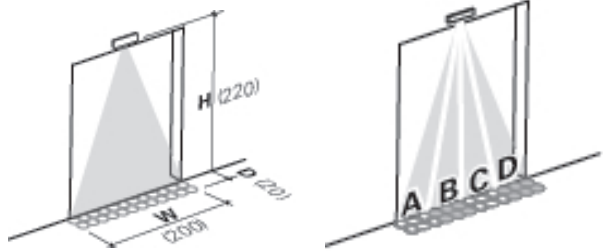

To prevent the safety device from being triggered unnecessarily, the AIR field should be limited to the door's movement range. If the AIR field is too large, the door cannot close if there are people next to the entrance. In the narrow door illustrated above, for example, the segments A and D and the segments A and B of the main closing edge on the side unnecessarily trigger the safety device.

Restrict the AIR field

- To prevent the safety device from being triggered unnecessarily, limit the AIR field to the required size.

Cover the lenses (A to D) for segments that are not required. Insert the enclosed plastic plates in the slots in front of the lenses. Select the plate size appropriate for the lens.

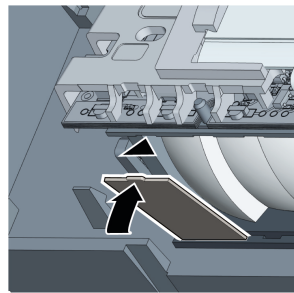
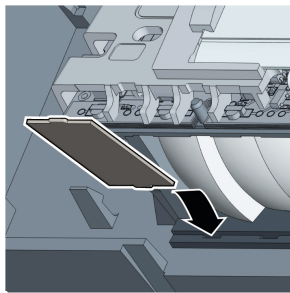
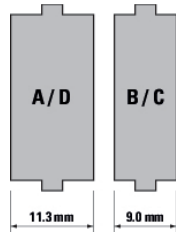

Set the AIR inclination angle

The AIR field must be aligned to the floor with the smallest possible distance to the door, but not to the door itself. If the AIR field recognizes the door, the door will not be able to close. The distance to the door can be adjusted continuously with the AIR angle adjustment.

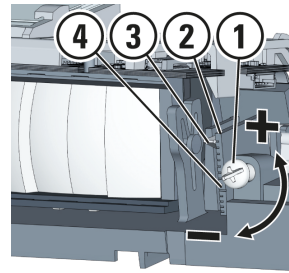

AIR angle adjustment

- 1 Adjusting screw
- 2 Inclination angle scale
- 3 Pointer
- 4 Marking 0°

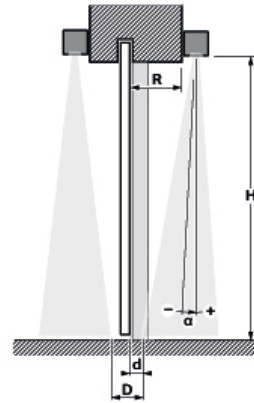

Cross section of the sliding door, with detectors and AIR fields opposite on both sides

- H** Mounting height of detector
- R** Distance between the detector and door
- α** AIR inclination angle (vertical: 0°)
- d** Distance between the AIR field and door
- D** Distance from AIR fields opposite

The AIR inclination angle is set to +6° at the factory.

- Use the AIR angle adjustment to adjust the inclination angle to the mounting situation. Select one of the following methods.

Method A (with connected detector):

- 1) Slide a sheet of paper under the door so that a white strip 5 to 8 cm deep (distance d) remains visible in front of the door.
- 2) Turn the adjusting screw (1) to the right until the AIR field detects the sheet of paper on the floor.

Method B (already possible during mounting preparation):

- 1) Measure the **depth R** of the lintel and the **mounting height H** of the detector.
- 2) Determine the appropriate **inclination angle α** using the guide value table.
- 3) Turn the adjusting screw (1) to the right until the pointer (3) on the scale (2) reaches the desired **inclination angle α** . At the 0° mark (4), the AIR field is aligned vertically downwards.

(mm)	Distance R						
Height H	0	50	100	150	200	250	300
1800	+6°	+5°	+3°	+1°	0°	-2°	-3°
2000	+6°	+5°	+3°	+2°	0°	-1°	-3°
2200	+5°	+4°	+3°	+2°	0°	-1°	-2°
2400	+5°	+4°	+3°	+2°	+1°	0°	-2°
2600	+5°	+4°	+3°	+2°	+1°	0°	-1°
2800	+5°	+4°	+3°	+2°	+1°	0°	-1°
3000	+5°	+4°	+3°	+2°	+1°	0°	-1°
3200	+5°	+4°	+3°	+2°	+1°	+1°	0°
3400	+5°	+4°	+3°	+2°	+2°	+1°	0°
3600	+5°	+4°	+3°	+2°	+2°	+1°	0°
3800	+5°	+4°	+3°	+2°	+2°	+1°	0°
4000	+5°	+4°	+3°	+2°	+2°	+1°	0°

Guide values for the inclination angle α



NOTE

for detector with ceiling mounting kit:

An AIR inclination angle $\alpha \geq 0^\circ$ simplifies the configuration, see section "**Ceiling mounting kit**". Refer to the table for the mounting distances R suitable for angle value $\geq 0^\circ$ at the intended mounting height H.

As soon as the detectors on both sides of the sliding door are set, measure the **distance D** between the AIR fields. Make sure that D is ≤ 18 cm. Test the safety device with a test specimen.

5 Operation

5.1 Commissioning

- 1) Remove all objects from the door area that are not part of the normal surroundings of the door system. Make sure that there are no people in the door area.
- 2) Start the sensor in the **QuickStart** menu.
- 3) Place the cover on the sensor.

The separator between the AIR light windows in the cover fits in the groove between the two AIR optics.

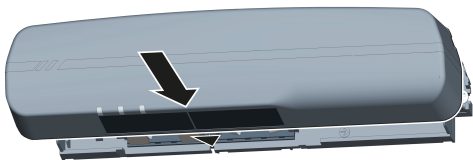

- 4) Wait until the LEDs stop flashing. Note: Continuous flashing signals indicate a fault, see section **Faults**.
- 5) Test the door system and, if necessary, modify the **Settings**.



WARNING

Risk of crushing if incorrectly adjusted

The safety function (presence detection) of the sensor must be set with sufficient sensitivity to detect people.

5.2 Status display

LED display	Operating status	
	lights up green	moving object in radar field
	lights up red	new object in AIR field
	flashes green	Radar hardware fault
	flashes red	a) AIR signal too strong/weak b) AIR break (15 minutes) c) AIR hardware fault
	alternately flashes red and green	Detector restart (9 seconds)
	flashes red and green at the same time	a) Power supply faulty b) Sensor defective
	flashes green quickly	5-second display for finding and assigning, triggered by CAN function

5.3 Maintenance

Monthly

- ▶ Test the safety device of the door system.

Annually

- ▶ Remove dust from the inside of the AIR windows.

6 Faults

Door fault pattern

LED signal

Display: possibly error code
Possible cause ▶ Possible remedies

Door opens and closes alternately with no one present

	LED lights up green
Radar detects door movement	a) Mechanical settings: Increase the inclination angle of the radar field (away from the door leaf). b) Configuration: Reduce the size of the radar field.

Door opens with no one present

	LED lights up green
Moving objects in the radar field	▶ Remove plants, signs, flags from the radar field.

 LED lights up green	
Radar interference due to vibration of the detector	▶ Mount the detector on a vibration-free surface.
Radar interference by fluorescent lights	▶ Configuration: Reduce the size of the radar field.
Radar interference by further detector	a) Mechanical settings: Swivel the radar field of the adjacent, interfering detector out of the detection area. b) Configuration: Reduce the size of the radar field. c) Configuration: Activate the radar filter.

Door opens with no one present

 LED flashes green	
Display: Message A2202 ... A2213 Sensor defective	▶ Replace the sensor.

Door does not close

 LED lights up red	
AIR detects door movement	▶ Mechanical settings: Increase the inclination angle of the AIR field (away from the door leaf).
Moving objects in the AIR field	▶ Remove plants, signs, flags from the AIR field.
AIR interference due to vibration of the detector	▶ Fix the mounting points of the detector.
AIR interference by fluorescent lights	▶ Use a different kind of lighting.
AIR interference due to puddles of water or snowfall	▶ Configuration: Decrease the AIR sensitivity. Caution! Safety-relevant function may be impaired.
AIR interference due to further detector	▶ AIR configuration: Select another frequency.
AIR interference due to door drive or other electromagnetic influences	a) Optimize the cabling (3.2 "Mounting preparation") b) Configuration: Decrease the AIR sensitivity. Caution! Safety-relevant function may be impaired.

Door does not move

 LEDs do not light up	
Presence detection (AIR) is configured incorrectly	▶ Configuration Output AIR : Switch between active and passive .

Door does not move

 LED flashes red	
Display: Message A2102 AIR signal too weak	a) Clean the AIR light windows and restart the detector (configuration/general/reset). b) Mechanical settings: Readjust the angle of the AIR field. Check the effect on the signal strength in the signal monitor (configuration info: AIR sign). c) Cover light-absorbing floors in the AIR field with a light-colored surface. Check the effect on the signal strength (configuration info: AIR sign).
Display: Message A2103 AIR signal too strong	a) Mechanical settings: Readjust the angle of the AIR field. Check the effect on the signal strength in the signal monitor (configuration info: AIR sign). b) Cover reflective floors in the AIR field with a matt surface. Check the effect on the signal strength (configuration info: AIR sign).
Display: Message A2104 ... 2121 Sensor defective	▶ Replace the sensor.

Door does not move

 LEDs flash red and green simultaneously	
Display: Message A2004 ... A2007 Supply voltage too low	▶ Ensure that the supply voltage is sufficient. If the supply voltage is guaranteed according to the technical data, replace the detector.
Display: Message E ... Sensor defective	▶ Replace the sensor.

6.1 Tools

In complicated environments and in the event of faults, the configuration menu offers an analysis tool and status data for the detector. Use this information for support requests as well.

Info configuration menu/menu group:

- Log data with messages and error codes
- AIR signal display for analysis
- Configuration code for support requests
- Operating hours counter
- Software version

AIR signal display

The detector has 3 infrared channels. Their signal level is displayed under **AIR sign.** Analysis of the signal level can help when configuring the detector in difficult ambient conditions.

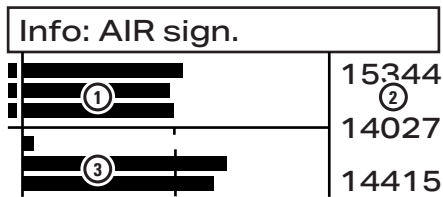

AIR signal level

- 1 Absolute values, visual
- 2 Absolute values, numerical
(Guide value with and without detection:
min. 180, max. 29000)
- 3 Values relative to the switch point (central), visual
(indicates whether a signal triggers switching)

Absolute values outside of the guide value thresholds can indicate e.g. problems with reflective or extremely light-absorbing floors. Changing the floor covering will fix the issue.

Observing the signal level can indicate whether unexpected detections are triggered due to door movements or electromagnetic influences of the door drive. Accordingly, problems can be fixed by adjusting the AIR inclination angle/cable routing for the door drive.

Allow manufacturer support to assist you in analysis.

Configuration code

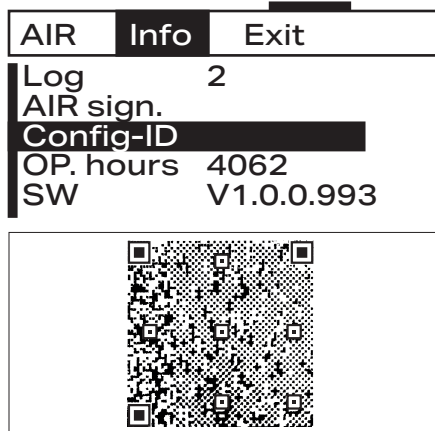

Under **Config ID**, the entire current device configuration is displayed as a QR code. If you require support, take a picture of the code and e-mail it to support.

✉ service@bircher.com ☎ +41 52 687 1366

7 Technical data

Technology	Active infrared (AIR) Radar
Mounting height	min. 1.8 m, max. 4.0 m EN 16005 up to 3.0 m DIN 18650 up to 3.0 m
Dimensions of field/spot on the floor	See the specifications for mounting height 2.20 m below

Dimensions of AIR field	max. 2.00 x 0.20 m
Dimensions of AIR spot	30 x 30 mm
Number of AIR spots	2 rows with 12 spots each
Performance level AIR	PLd, Cat. 2 (EN ISO 13849-1)
Dimensions of wide radar field (W x L)	min. 1.90 x 1.00 m, max. 4.00 x 2.00 m
Dimensions of narrow radar field (W x L)	min. 1.00 x 4.00 m, max. 2.00 x 4.00 m
Radar transmission frequency	24.2 GHz
Radar transmission output	< 13 dBm
Radar performance level	PLd, Cat. 2 (EN ISO 13849-1) for frequency or voltage output

Interface

Bus protocol	CANopen acc. to 50325
Safety concept	IEC 61784-3
Performance level CAN	PLd, Cat. 2 (EN ISO 13849-1)
Available bit rates	125 kbit/s, 250 kbit/s
Available network addresses	1 – 127

Mechanical data

Housing material	ABS / PA
Housing color	black, silver, white
Dimensions (L x W x D)	252 x 61 x 51 mm
Weight	250 g
Protection class	IP54 (EN 60529)

Electrical data

Supply voltage	11.5 – 32 V DC
Operating current	max. 120 mA at 24 V
Inrush current	max. 240 mA

Ambient conditions

Ambient temperature	min. -20 °C, max. +60 °C
Relative humidity	max. 95 %, non-condensing

Disposal



The product contains electrical or electronic components. Do not dispose of the product with household waste.

Notice on conformity



BBC Bircher AG declares that this product conforms with the following guidelines and directives of the EU:

MD 2006/42/EC RED 2014/53/EU
RoHS 2011/65/EU

EC type-examination certificate:
44 205 13131912 0044 TÜV NORD

For the detailed Declaration of Conformity, follow the QR code or link below.

Technical documentation



You will find all documents on the manufacturer website
www.bircher.com

8 Contact

If you have any questions about the device, please contact us:

✉ service@bircher.com ☎ +41 52 687 1366

BBC Bircher Smart Access

BBC Bircher AG, Wiesengasse 20, CH-8222 Beringen
www.bircher.com