

Factory Automation

MELSEC iQ-F Series

FX5U-32MT/ES Specifications

Performance specifications

Control system		Stored-program repetitive operation
Input/output control system		Refresh system (Direct access input/output allowed by specification of direct access input/output [DX, DY])
No. of input/output points	(1) No. of input/output points	256 points or less/384 points or less* *Supported with CPU module firmware version 1.100 and later. In addition, GX Works3 version 1.047Z and later is required.
	(2) No. of remote I/O points	384 points or less/512 points or less* *Supported with CPU module firmware version 1.100 and later. In addition, GX Works3 version 1.047Z and later is required.
	Total No. of points of (1) and (2)	512 points or less
Programming specifications	Programming language	Ladder diagram (LD), structured text (ST), function block diagram/ladder diagram (FBD/LD), sequential function chart (SFC)* *For supported versions, refer to MELSEC iQ-F FX5 User's Manual (Application).
	Programming extension function	Function block (FB), function (FUN), label programming (local/global)
	Constant scan	0.2 to 2000 ms (can be set in 0.1 ms increments)
	Fixed cycle interrupt	1 to 60000 ms (can be set in 1 ms increments)
	Timer performance specifications	100 ms, 10 ms, 1 ms
	No. of program executions	32
	No. of FB files	16 (Up to 15 for user)
Operation specifications	Execution type	Standby type, initial execution type, scan execution type, fixed scan execution type, event execution type
	Interrupt type	Internal timer interrupt, input interruption, high-speed comparison match interrupt, interrupt by modules* *Interrupt from the intelligent function module and high-speed pulse input/output module.
Command processing time	LD X0	34 ns* *When the program capacity is 64 k steps.
	MOV D0 D1	34 ns* *When the program capacity is 64 k steps.
Memory capacity	Program capacity	64 k steps/128 k steps* (128 kbytes/256 kbytes, flash memory) *Supported with CPU module firmware version 1.100 or later. In addition, GX Works3 version 1.047Z or later is required.
	SD memory card	Memory card capacity (SD/SDHC memory card: Max. 16 Gbytes)
	Device/label memory	120 kbytes
	Data memory/standard ROM	5 Mbytes
Flash memory (Flash ROM) write count		Maximum 20000 times
		1

File storage capacity	Device/label memory		32
	Data memory	P: No. of program files	16
		FB: No. of FB files	511
	SD memory card	2 Gbytes	The number of files stored in the root folder. 65534
		4 Gbytes, 8 Gbytes, 16 Gbytes	The number of files stored in the root folder. Year, month, day, hour, minute, second, day of week (leap year automatic detection)
Clock function	Display data		Differences per month ± 45 sec./25°C (TYP)
	Precision		Large-capacity capacitor Clock data is retained using the power accumulated in a large-capacity capacitor incorporated into the PLC. When voltage of the large-capacity capacitor drops, clock data is no longer accurately retained. The retention period of a fully charged capacitor (electricity is conducted across the PLC for at least 30 minutes) is 10 days (ambient temperature: 25°C). How long the capacitor can hold the data depends on the operating ambient temperature. When the operating ambient temperature is high, the holding period is short.
Power failure retention (clock data)	Retention method		10 days (Ambient temperature: 25°C)
	Retention time		Maximum 12 k word
Power failure retention (device)	Power failure retention capacity		It is possible to back up all devices in device (high-speed) area. When a battery is used, it is also possible to back up devices in device (standard) area.
Number of device points			1024 points
No. of user device points	Input relay (X)	Octal	The total number of X and Y assigned to I/O points is up to 256 points/384 points* *Supported with CPU module firmware version 1.100 or later. In addition, GX Works3 version 1.047Z or later is required.
			1024 points
	Output relay (Y)	Octal	The total number of X and Y assigned to I/O points is up to 256 points/384 points* *Supported with CPU module firmware version 1.100 or later. In addition, GX Works3 version 1.047Z or later is required.
			32768 points (can be changed with parameter)
	Internal relay (M)	Decimal	Can be changed with parameters within the capacity range of the CPU built-in memory.
			32768 points (can be changed with parameter)
	Latch relay (L)	Decimal	Can be changed with parameters within the capacity range of the CPU built-in memory.
			32768 points (can be changed with parameter)
	Link relay (B)	Hexadecimal	Can be changed with parameters within the capacity range of the CPU built-in memory.
			32768 points (can be changed with parameter)
	Annunciator (F)	Decimal	Can be changed with parameters within the capacity range of the CPU built-in memory.
			32768 points (can be changed with parameter)
	Link special relay (SB)	Hexadecimal	Can be changed with parameters within the capacity range of the CPU built-in memory.
			4096 points (fixed)
	Step relay (S)	Decimal	1024 points (can be changed with parameter)
Can be changed with parameters within the capacity range of the CPU built-in memory.			
Timer system (Timer (T))	Decimal	1024 points (can be changed with parameter)	
		Can be changed with parameters within the capacity range of the CPU built-in memory.	
Accumulation timer system (Accumulation timer (ST))	Decimal	1024 points (can be changed with parameter)	
		Can be changed with parameters within the capacity range of the CPU built-in memory.	
Counter system (Counter (C))	Decimal	1024 points (can be changed with parameter)	
		Can be changed with parameters within the capacity range of the CPU built-in memory.	
Counter system (Long counter (LC))	Decimal	8000 points (can be changed with parameter)	
		Can be changed with parameters within the capacity range of the CPU built-in memory.	
Data register (D)	Decimal	32768 points (can be changed with parameter)	
		Can be changed with parameters within the capacity range of the CPU built-in memory.	
Link register (W)	Hexadecimal	32768 points (can be changed with parameter)	
		Can be changed with parameters within the capacity range of the CPU built-in memory.	

	Link special register (SW)	Hexadecimal	32768 points (can be changed with parameter) Can be changed with parameters within the capacity range of the CPU built-in memory.
No. of system device points	Special relay (SM)	Decimal	10000 points (fixed)
	Special register (SD)	Decimal	12000 points (fixed)
Module access device	Intelligent function module device	Decimal	65536 points (designated by U□\G□)
No. of index register points	Index register (Z)	Decimal	24 points The sum of index register (Z) and long index register (LZ) is 24 words.
	Long index register (LZ)	Decimal	12 points The sum of index register (Z) and long index register (LZ) is 24 words.
No. of file register points	File register (R)	Decimal	32768 points (can be changed with parameter) Can be changed with parameters within the capacity range of the CPU built-in memory.
	Extended file register (ER)	Decimal	32768 points (are stored in SD memory card)
No. of nesting points	Nesting (N)	Decimal	15 points (fixed)
No. of pointer points	Pointer (P)	Decimal	4096 points
	Interrupt pointer (I)	Decimal	178 points (fixed)
Others	Decimal constant (K)	Signed	16 bits: -32768 to +32767 32 bits: -2147483648 to +2147483647
		Unsigned	16 bits: 0 to 65535 32 bits: 0 to 4294967295
	Hexadecimal constant (H)		16 bits: 0 to FFFF 32 bits: 0 to FFFFFFFF
	Real constant (E)	Single precision	E-3.40282347+38 to E-1.17549435-38, 0, E1.17549435-38 to E3.40282347+38
	Character string		Shift-JIS code max. 255 single-byte characters (256 including NULL)
Power supply specifications			
Rated voltage		100 to 240 V AC	
Voltage fluctuation range		-15%, +10%	
Frequency rating		50/60 Hz	
Allowable instantaneous power failure time		Operation can be continued upon occurrence of instantaneous power failure for 10 ms or less. When the supply voltage is 200 V AC or higher, the time can be change to 10 to 100 ms by editing the user program.	
Power fuse		250 V, 3.15 A Time-lag fuse	
Rush current		25 A max. 5 ms or less/100 V AC 50 A max. 5 ms or less/200 V AC	
Power consumption		30 W This item shows value when all 24 V DC service power supplies are used in the maximum configuration connectable to the CPU module. (The current of the input circuit is included.)	
24 V DC service power supply capacity		[When using 24 V DC service power supply for input circuit of CPU module] Ambient temperature 0 to 55°C: 400 mA Ambient temperature is lower than 0°C: 300 mA [When using external power supply for input circuit of CPU module] Ambient temperature 0 to 55°C: 480 mA Ambient temperature is lower than 0°C: 380 mA When I/O modules are connected, they consume current from the 24 V DC service power supply. For details on the 24 V DC service power supply, refer to MELSEC IQ-F FX5S/FX5UJ/FX5U/FX5UC User's Manual (Hardware).	
5 V DC built-in power supply capacity		900 mA	
Input specifications			
No. of input points		16 points	
Input connection type		Removable terminal block (M3 screws)	

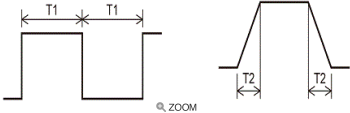
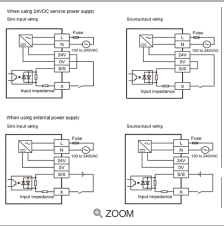
Input type	Sink/source	
Input signal voltage	24 V DC +20%, -15%	
Input signal current	X0 to X17	5.3 mA/24 V DC
Input impedance	X0 to X17	4.3 kΩ
ON input sensitivity current	X0 to X17	3.5 mA or more
OFF input sensitivity current	1.5 mA or less	
Input response frequency	X0 to X5	200 kHz When capturing pulses of a response frequency of 50 to 200 kHz, refer to MELSEC iQ-F FX5S/FX5UJ/FX5U/FX5UC User's Manual (Hardware).
	X6 to X17	10 kHz
Pulse waveform		
	X0 to X5	T1 (pulse width): 2.5 μs or more T2 (rise/fall time): 1.25 μs or less
	X6 to X17	T1 (pulse width): 50 μs or more T2 (rise/fall time): 25 μs or less
Input response time (H/W filter delay)	X0 to X5	ON: 2.5 μs or less OFF: 2.5 μs or less
	X6 to X17	ON: 30 μs or less OFF: 50 μs or less
Input response time (Digital filter setting value)	None, 10 μs, 50 μs, 0.1 ms, 0.2 ms, 0.4 ms, 0.6 ms, 1 ms, 5 ms, 10 ms (initial values), 20 ms, 70 ms When using this product in an environment with much noise, set the digital filter.	
Input signal format (Input sensor form)	No-voltage contact input Sink: NPN open collector transistor Source: PNP open collector transistor	
Input circuit insulation	Photo-coupler insulation	
Indication of input operation	LED is lit when input is on	
Input circuit configuration		
Output specifications		
No. of output points	16 points	
Output connection type	Removable terminal block (M3 screws)	
Output type	Transistor/sink output	
External power supply	5-30 V DC	
Max. load	0.5 A/point The total load current per common terminal should be the following value. 4 output points/common terminal: 0.8 A or less	
Open circuit leakage current	0.1 mA or less/30 V DC	
Voltage drop when ON	Y0 to Y3	1.0 V or less
	Y4 and subsequent	1.5 V or less
Response time	Y0 to Y3	2.5 μs or less/10 mA or more (5-24 V DC)

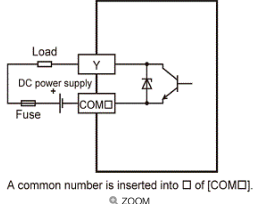
	Y4 and subsequent	0.2 ms or less/200 mA or more (24 V DC)
Output circuit insulation		Photo-coupler insulation
Indication of output operation		LED is lit when output is on
Output circuit configuration		 <p>A common number is inserted into □ of [COM□].</p> <p>Q, ZOOM</p>

Function specifications

Firmware update function		This function updates the module's firmware using an SD memory card.
Scan monitoring function (Watchdog timer setting)		Detects an error in the hardware and program of the CPU module by monitoring the scan time.
Clock function		This function is used for the time management in the function which the system operates such as the date of the event history function, and data logging function.
Online change	Online ladder block change	Writes the part of a program edited on the ladder editor using the engineering tool to the CPU module in units of ladder blocks. Edited contents spanning multiple portions can be written to the CPU module at once.
Interrupt function	Multiple interrupt function	When an interrupt occurs while an interrupt program triggered by another cause is running, stops the program if its priority is lower than that of the new interrupt, and runs the higher-priority program whenever its execution condition is satisfied.
PID control function		Performs PID control by the PID control instruction.
Constant scan		Keeps the scan time constant and executes program repeatedly.
Remote operation	Remote RUN/STOP	Changes the CPU module status to the RUN/STOP/PAUSE status externally while the RUN/STOP/RESET switch of the CPU module is in RUN status.
	Remote PAUSE	Changes the CPU module status to the RUN/STOP/PAUSE status externally while the RUN/STOP/RESET switch of the CPU module is in RUN status.
	Remote RESET	Resets the CPU module externally while the CPU module is in the STOP status.
Device/label memory area setting		Sets the capacity of each area in the device/label memory.
Program capacity setting		Set to change program capacity.
Internal buffer capacity setting		Sets the capacity of the area (internal buffer) used by the system to temporarily store the results of data logging and memory dump processing.
Initial device value setting		Sets the initial values of devices used in the program directly (not via the program) to the devices.
Latch function		Holds the contents of the device and label of the CPU module when the power is turned ON etc.
Memory card function	SD memory card forced stop	Makes the SD memory card unavailable without turning OFF the power even when the function accessing the SD memory card is executed.
	Boot operation	Transfers the file stored in the SD memory card to the transfer destination memory judged automatically by the CPU module when the power is turned ON or is reset.
Device/label access service processing setting		Sets the number of execution times of the device/label access service processing executed by END processing, with parameter.
Data logging function		Collects data at the specified interval or any desired timing, and stores them as a file on the SD memory card.
Memory dump function		Saves the data in the devices of the CPU module at a desired timing.
Real-time monitor function		Monitors the data in the specified device of the CPU module at a specified interval or at a desired timing in real time.
RAS function	Self-diagnostics function	Self-diagnoses the CPU module to see whether an error exist or not.
	Error clear	Batch-clears all the continuation errors being detected.

	Event history function	Collects operations executed and errors detected from the modules, and saves them in the CPU module, expansion board, expansion adapter, and intelligent module. The saved logs can be checked in chronological order.
Data backup/restoration function		Backs up program files, parameter files, and device/label data files in a CPU module to an SD memory card. The backup data can be restored as needed.
Security function		Protects resources stored in PCs and resources in the units in the system of the FX5 from illegal access by a third party such as theft, alteration, accidental operation and unauthorized execution.
IP filter function		Identifies the IP address of external devices over Ethernet, and blocks access from an invalid IP address.
High-speed input/output function	High-speed counter function	Performs high-speed counter, pulse width measurement, input interruption, etc. by using the input of the CPU module or high-speed pulse input/output module.
	Pulse width measurement function	Performs high-speed counter, pulse width measurement, input interruption, etc. by using the input of the CPU module or high-speed pulse input/output module.
	Input interrupt function	Performs high-speed counter, pulse width measurement, input interruption, etc. by using the input of the CPU module or high-speed pulse input/output module.
	Positioning function	Executes positioning operation by using the transistor output of the CPU module or high-speed pulse input/output module.
	PWM output function	Executes a PWM output by using the transistor output of the CPU module or high-speed pulse input/output module.
Built-in analog function	Analog input function	Two analog inputs are built in the FX5U CPU module so that voltage input can be performed.
	Analog output function	One analog output are built in the FX5U CPU module so that voltage output can be performed.
Built-in Ethernet function		An Ethernet related function such as connection to MELSOFT products and GOTs, socket communication, file transfer using FTP, Web server (HTTP), SNMP client, and simple CPU communication function.
CC-Link IE Field Network Basic function		This function exchanges data between the manager station and remote station using general-purpose Ethernet.
Serial communication function		A function related to the serial communication such as N:N Network, parallel link, MC protocol, inverter communication function and non-protocol communication.
MODBUS communication function		Connection with the products which support MODBUS RTU/TCP is available. The master and slave functions can be used.

General specifications

Operating ambient temperature			-20 to 55°C, non-freezing The simultaneous ON ratio of available PLC inputs or outputs changes with respect to the ambient temperature, refer to MELSEC iQ-F FX5S/FX5UJ/FX5U/FX5UC User's Manual (Hardware). The operating ambient temperature is 0 to 55°C for products manufactured before June 2016. For details on Intelligent function modules, refer to manuals of each product. In the case where operating ambient temperature is lower than 0°C, the specifications are different from the above description. For details, refer to MELSEC iQ-F FX5S/FX5UJ/FX5U/FX5UC User's Manual (Hardware).
Storage ambient temperature			-25 to 75°C, non-freezing
Operating ambient humidity			5 to 95%RH, non-condensation When used in a low-temperature environment, use in an environment with no sudden temperature changes. If there are sudden temperature changes because of opening/closing of the control panel or other reasons, condensation may occur, which may cause a fire, fault, or malfunction. Furthermore, use an air conditioner in dehumidifier mode to prevent condensation.
Storage ambient humidity			5 to 95%RH, non-condensation
Vibration resistance	Installed on DIN rail	Frequency: 5 to 8.4 Hz	Half amplitude: 1.75 mm 10 times each in X, Y, Z directions (80 min in each direction) The criterion is shown in IEC61131-2. When the system has equipment which specification values are lower than above mentioned vibration resistance specification values, the vibration resistance specification of the whole system is corresponding to the lower specification.
		Frequency: 8.4 to 150 Hz	Acceleration: 4.9 m/s ² 10 times each in X, Y, Z directions (80 min in each direction) The criterion is shown in IEC61131-2. When the system has equipment which specification values are lower than above mentioned vibration resistance specification values, the vibration resistance specification of the whole system is corresponding to the lower specification.
	Direct installing	Frequency: 5 to 8.4 Hz	Half amplitude: 3.5 mm 10 times each in X, Y, Z directions (80 min in each direction) The criterion is shown in IEC61131-2.

		When the system has equipment which specification values are lower than above mentioned vibration resistance specification values, the vibration resistance specification of the whole system is corresponding to the lower specification.
	Frequency: 8.4 to 150 Hz	Acceleration: 9.8 m/s^2 10 times each in X, Y, Z directions (80 min in each direction) The criterion is shown in IEC61131-2. When the system has equipment which specification values are lower than above mentioned vibration resistance specification values, the vibration resistance specification of the whole system is corresponding to the lower specification.
Shock resistance		147 m/s^2 , Action time: 11 ms, 3 times by half-sine pulse in each direction X, Y, and Z The criterion is shown in IEC61131-2.
Noise durability		By noise simulator at noise voltage of 1000 Vp-p, noise width of 1 μs and period of 30 to 100 Hz
Dielectric withstand voltage	Between power supply terminal (AC power supply) and ground terminal	1.5 kV AC for one minute
	Between 24 V DC service power supply connected to input terminal (24 V DC) and ground terminal	500 V AC for one minute
	Between output terminal (transistor) and ground terminal	500 V AC for one minute
Insulation resistance	Between power supply terminal (AC power supply) and ground terminal	10 M Ω or higher by 500 V DC insulation resistance tester
	Between 24 V DC service power supply connected to input terminal (24 V DC) and ground terminal	10 M Ω or higher by 500 V DC insulation resistance tester
	Between output terminal (transistor) and ground terminal	10 M Ω or higher by 500 V DC insulation resistance tester
Grounding		Class D grounding (grounding resistance: 100 Ω or less) (Common grounding with a heavy electrical system is not allowed) For grounding, refer to MELSEC iQ-F FX5S/FX5UJ/FX5U/FX5UC User's Manual (Hardware).
Working atmosphere		Free from corrosive or flammable gas and excessive conductive dust
Operating altitude		0 to 2000 m The PLC cannot be used at a pressure higher than the atmospheric pressure to avoid damage.
Installation location		Inside a control panel The programmable controller is assumed to be installed in an environment equivalent to indoor.
Overvoltage category		II or less This indicates the section of the power supply to which the equipment is assumed to be connected between the public electrical power distribution network and the machinery within premises. Category II applies to equipment for which electrical power is supplied from fixed facilities. The surge voltage withstand level for up to the rated voltage of 300 V is 2500 V.
Pollution degree		2 or less This index indicates the degree to which conductive material is generated in the environment in which the equipment is used. Pollution level 2 is when only non-conductive pollution occurs. Temporary conductivity caused by condensation must be expected occasionally.