

Product Brochure

Industrial robot arm / Collaborative robot arm / Electric gripper /
Intelligent actuator / Automation solutions

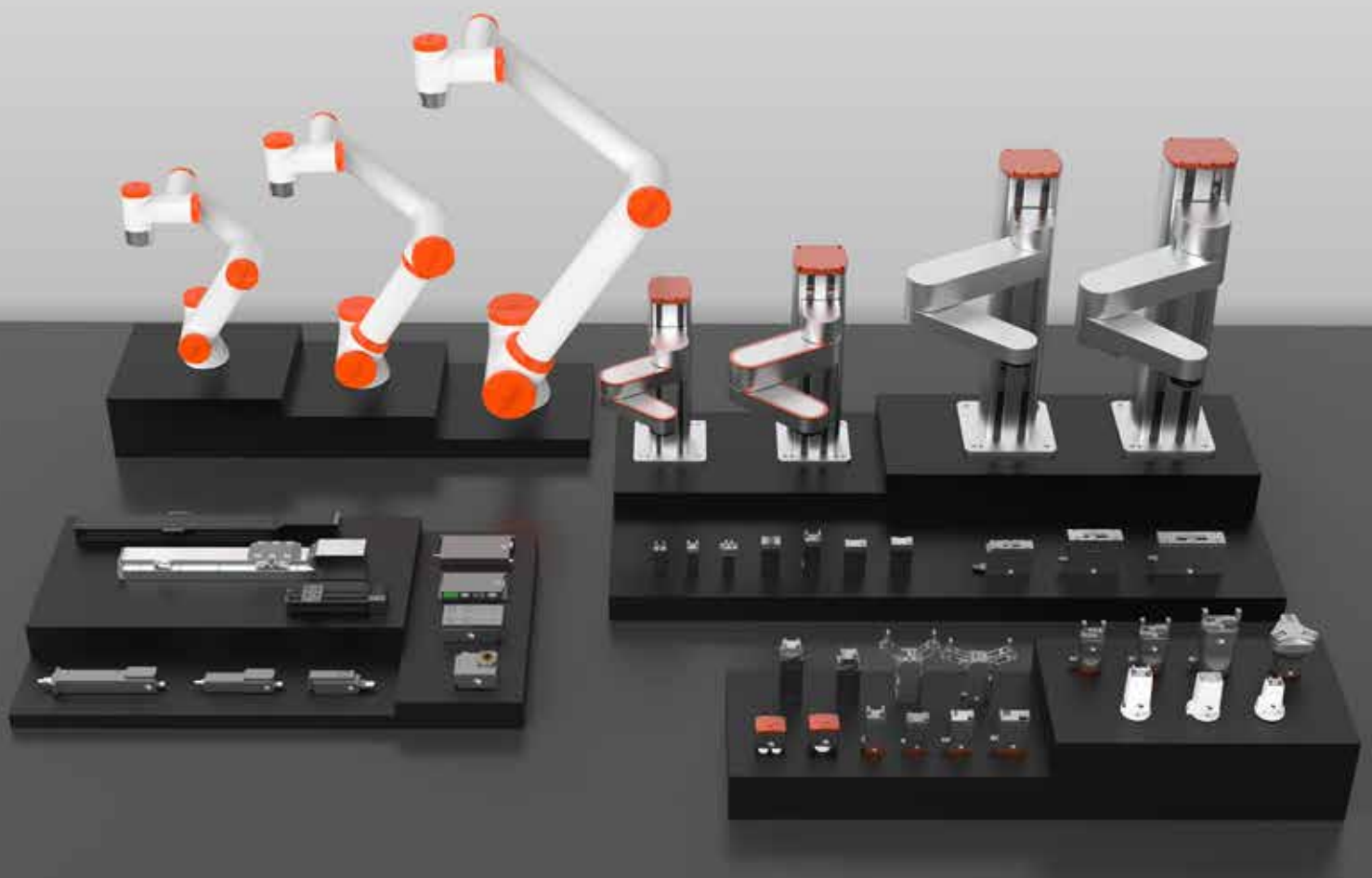



Making Automation Easier



 YouTube



 LinkedIn



 Company website

Content

About Hitbot	01
Company Introduction	01
Honor & Cooperation	02
Product Series	03
Industry Application	04
HITBOT OS Software	07
Hitbot OS Platform Advantages	07
Differences with Traditional PLC	10
Hitbot OS Platform Controller	12
Robotic Arm Series	15
Four-axis Robotic Arm	22
Six-axis Robotic Arm	43
Introduction to Robot Software	53
Gripper for Six-axis Robotic Arm	54
Gripper for Four-axis Robotic Arm	55
Electric Gripper Series	56
Z-EFG Series	64
Z-ECG Series	90
Z-ERG Series	92
Electric Suction Cup Series	94
Z-ESC Series	95
Linear Rotary Actuator	96
Z-Mod-LRA Series	97
Intelligent Electric Actuator Series	99
Z-Mod-SE Series	103
Z-Mod-KK Series	110
Actuator Model Definition	113
Z-Mod-EPA Series	114
Z-Mod-MS Series	115
Z-Mod-RP Series	116
Software Introduction	118
Accessory Package	123
Accessory Definition	123
Accessories Package List	123
Machining	125
Frequently Asked Questions	127



Company Introduction

Huiling-tech (HITBOT) Robotic Co., Ltd, a Xiaomi ecological chain enterprise, was founded in 2015 and is a leading player in the electric gripper industry and the pioneer of direct-drive robotic arms. We focus on the research and development of core technology, adhere to product innovation, and provide industry customers with ultimate cost-effective robot products and automation solutions in an efficient, low-cost, and modular way. We are committed to making automation simpler and have made robots more accessible to the automation industry, reducing the barriers to automation transformation from multiple perspectives such as cost and usability. Our products have been deployed in dozens of countries such as the United States, Germany, Japan, and South Korea, and have been widely applied in various fields such as 6C, healthcare, new retail, automotive, education, and have served thousands of customers such as Xiaomi, Huawei, Foxconn, and Panasonic.

Honor & Cooperation

Honors

HITBOT has a strong technical team that gathers top technical talents. With its comprehensive strength, we provide customers with efficient and professional robotic arm and related product solutions. We have obtained over 330 patents, including more than 60 invention patents, and have received multiple domestic awards. Our products have also been CE and FCC certified.



330+ patents, including 60+ invention patents



10+ domestic awards



Specialized and innovative enterprise



CE, FCC Certified



Part of our partners



Product Series

Standard Product



Four-axis Robotic Arm

Pioneer of direct-drive robotic arms

With high precision, small size, and more flexible inner-side rotation of the arm, the product is highly integrated and designed as a one-piece unit, without an external control box. The Z-axis height can be customized, and it also supports exclusive advantages such as inverted deployment.

Six-axis Robotic Arm

Making Automation Easily

With high precision, large load capacity, and high integration, the product uses drag-and-play teaching and graphical programming, as well as collision detection and customized collision level to reduce the operational threshold and facilitate application in various industries.

End Effector

Leading Flexible Gripping Solutions

With an internally integrated servo system, the end effectors can meet flexible gripping requirements for production, enabling digital control, precise control of speed, position, and gripping force.

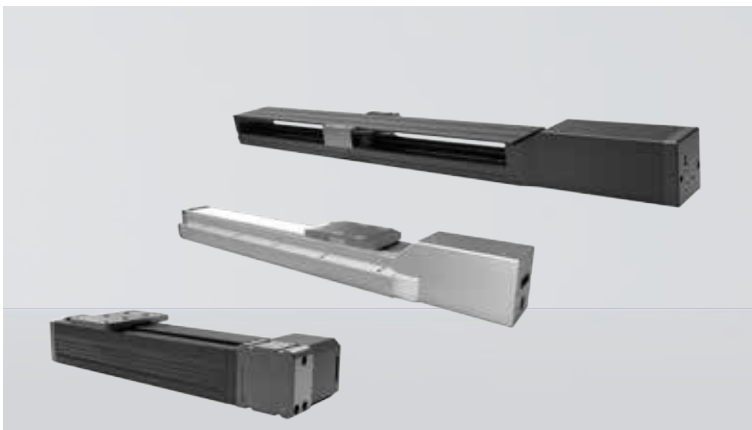

Intelligent Actuator

Ultimate cost-effectiveness

The intelligent electric actuator eliminates the need for couplings, highly integrates the external motor and controller, and achieves ultimate space utilization and maximum stroke utilization.

Industry Solution

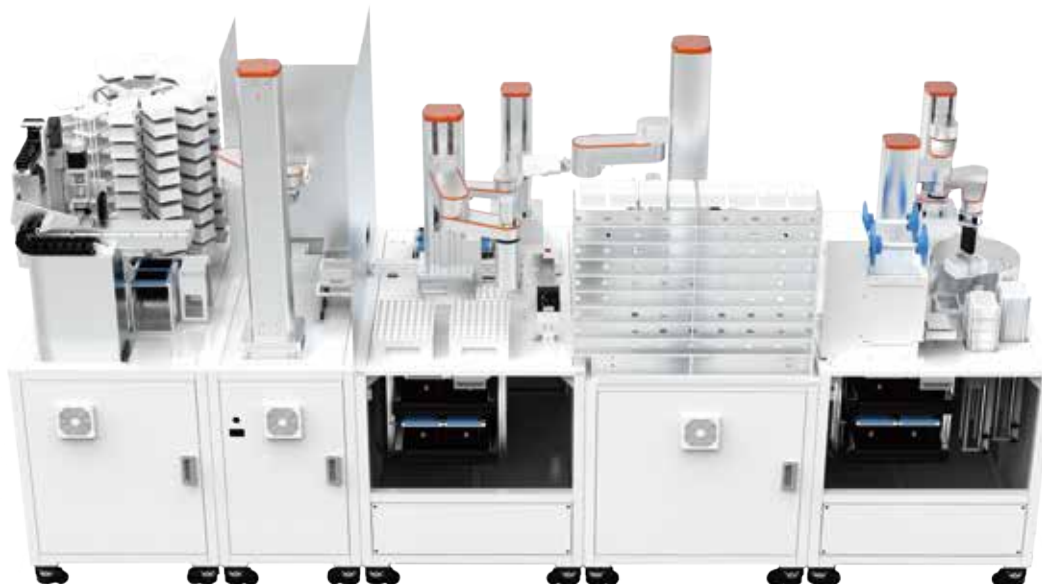

Fully Automatic Nucleic Acid Detection Line

Customized fully automatic detection line services are provided according to different requirements such as site, throughput, consumables, and detection process. The line can integrate customer's existing instruments and equipment such as sample distribution, nucleic acid extraction, liquid transfer workstation, QPCR, biosafety cabinet, etc., reducing integration costs and shortening the cycle. It can also add functions such as labeling and support for mixing 10 or more samples, freeing up high-end laboratory talent and achieving one-stop service

Cap-Twist Module

Life Sciences

Synthetic Biology Laboratory, Molecular Biology Laboratory, Gene Synthesis/Microbiology Laboratory, Cell Biology Laboratory, Biochemistry Laboratory, Nucleic Acid Detection, Protein Expression, Bacterial Strain Construction and Screening, Medium Formulation Optimization, Fermentation Process Development...

Life Science

Microbial Testing and Identification in Drugs, Clinical Samples, and Cosmetics...

Food Science

Microbial Monitoring and Identification in Food...

Environmental Science

Microbial Monitoring and Identification in the environment...

Any other scenario involving the switch of a screw cap



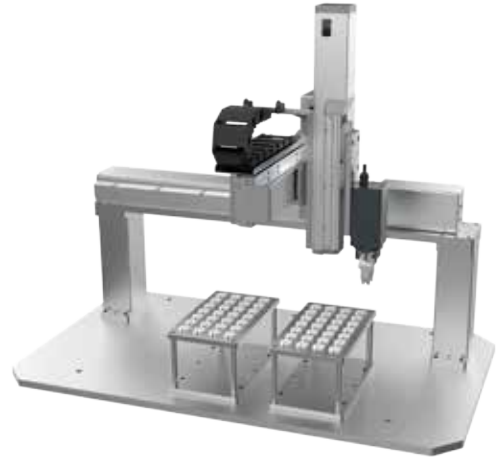

Three-axis Electric Actuator Retrieval Equipment

Simple, flexible, and highly profitable, making automation incredibly easy. The purchase cost is reduced by 50%, with an integrated motor and distributed control board solution, eliminating high-cost equipment such as PLCs and serial port servers. Labor costs are reduced by 40%, with no need for separate programming of the electrical control part. Engineers only need to add electrical and executive control components in the HFlow system to complete the development of the drive. After-sales costs are reduced by 90%, with modular construction, module assembly, and less wiring in the integrated bus, making maintenance simple.



Automatic Assembly Line for Temperature and Humidity Meter

Different products, sites, and processes can be spliced and combined to provide fully customized automation for products with significantly different processes. Other functions such as assembly, screw locking, glue dispensing, welding, and packaging can also be added as needed. It supports hardware control such as PLCs and industrial computers, and the software can be added, deleted, or changed according to specific processes. The device comes with operation manuals and videos for all components, as well as case-based operating guides and teaching experiments, making it extremely suitable for teaching guidance.



Medical Industry



6C Electronics Industry



Other Industries



Education Industry

Industry Application

The 6C electronics industry, medical and chemical industry, testing industry, new retail, food and beverage, automotive parts industry, textile industry, plastic industry, scientific research education, and makers.



Chemical Industry



Automobile Industry



Advanced Manufacturing



New Retail Industry

Application Scenarios

Loading and unloading of finished products and parts, sorting and holding of samples for testing, circuit board welding, dispensing, screwing, 3D printing, laser engraving.

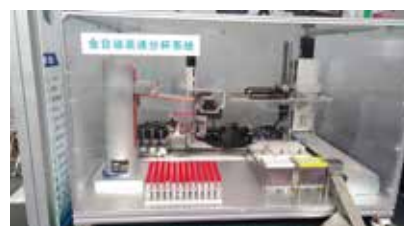
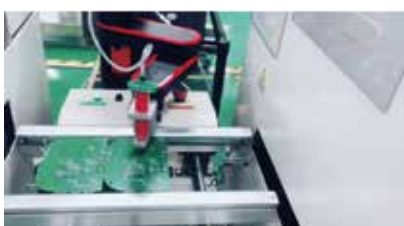

HOTBOT Operating System



HITBOT Operating System

Hitbot Operating System is a domestic automation software independently developed by Hitbot, the software integrates equipment programming, control, and design, and can realize the whole design process from scheme design, landing, implementation, and maintenance.

In the scheme design stage, the scheme design efficiency can be improved through scene construction, design model import, simulation editing, measurement, etc.; electrical topology diagram, through standardized robot control language, you can quickly complete wiring and equipment debugging by simply dragging modules, reducing the difficulty of wiring and equipment debugging; graphical programming, in a virtual environment, through visual workflow, replaces the programming of many modeling tasks with simple machine motion programming; digital twin, the software runs consistently with the actual equipment, with the help of real-time data and algorithm models, simulates, verifies, predicts, and controls remote equipment, with automatic saving and co-editing functions, real-time remote viewing of equipment status, empowering non-standard automation industry equipment suppliers and solution engineers to make automation easier

1

Quick establishment,improve the efficiency of solution design.

Choose Hitbot standardized equipment for different industries, disassemble 3D models for import, quickly build production line solutions, and realize 3D scene equipment assembly. Conduct various attempts and layouts in a simulation environment to quickly verify the feasibility of the solution, reduce trial and error costs, and improve solution design efficiency.

2

Virtual debugging,virtual-real electrical connection reduces debugging difficulty.

Hitbot's integrated software control platform system achieves unification with the hardware controller, 1:1 electrical connection between virtual and real devices, and standardized control language with portable drag operation, making it easy to complete wiring connection and debugging between devices.

3

Even without programming knowledge, you can easily get started with BLOCKLY graphical programming

The integrated platform combines advanced graphical programming technology with humanized design, and has a rich equipment library and the ability to quickly build non-standard automation. In a virtual environment, you can quickly start machine motion programming, visualize workflows, replace many modeling tasks, and make machine motion programs simpler. Even people without a good programming ability can easily start programming operations.

4

Digital twin deployment,shorten project cycle

The integrated platform has the function of modular installation and deployment. It can quickly build an automated production line in the form of Lego. Through 3D simulation software, it can build scenes, import design models, perform simulation editing, and measure, and realize a series of operations such as the first hardware motion simulation. At the same time, the twin production line data can detect and optimize the operating status of the production line in real time, realizing the virtual-real synchronization of the actual scene and the twin system.

5

Large third-party equipment library

The third-party equipment library of Hitbot Integrated Platform has great scale advantages. It not only covers the largest hardware matrix of Hitbot brand standardized hardware (six-axis robotic arms, four-axis robotic arms, electric grippers and intelligent actuators), but also is compatible with most brands of automation products on the market. No matter what kind of equipment you have, as long as it can communicate, it can be easily integrated into Hitbot Integrated Platform.

Ordinary development process

Ordinary development does not require the installation of any software, and you can start your project creation with just a browser. It is easily accessible anytime and anywhere, without being restricted by devices and environments. The simple operation interface and efficient development process allow your ideas to be quickly implemented. It saves developers time and energy, improves development efficiency, and is your ideal choice for completing automation projects.

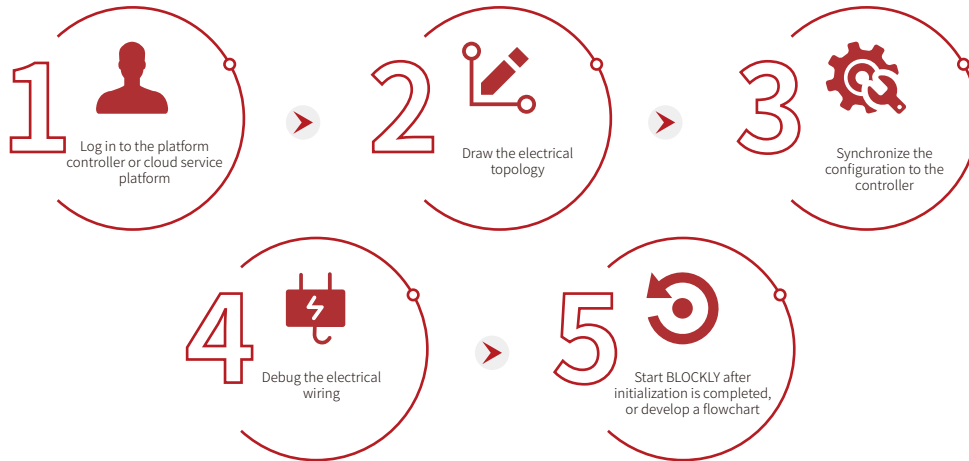

Digital twin process

Hitbot operating system, innovation leads the future. Its digital twin function is powerful, and requires a separate installation program, but it can open up a new development experience for you. Accurately simulate the actual operation of the equipment, and use real-time data and algorithm models to achieve remote simulation, verification, prediction and control of equipment. Automatic saving and co-editing functions make collaboration more efficient. Whether it is solution optimization or troubleshooting, digital twins can provide powerful assistance to escort your project.

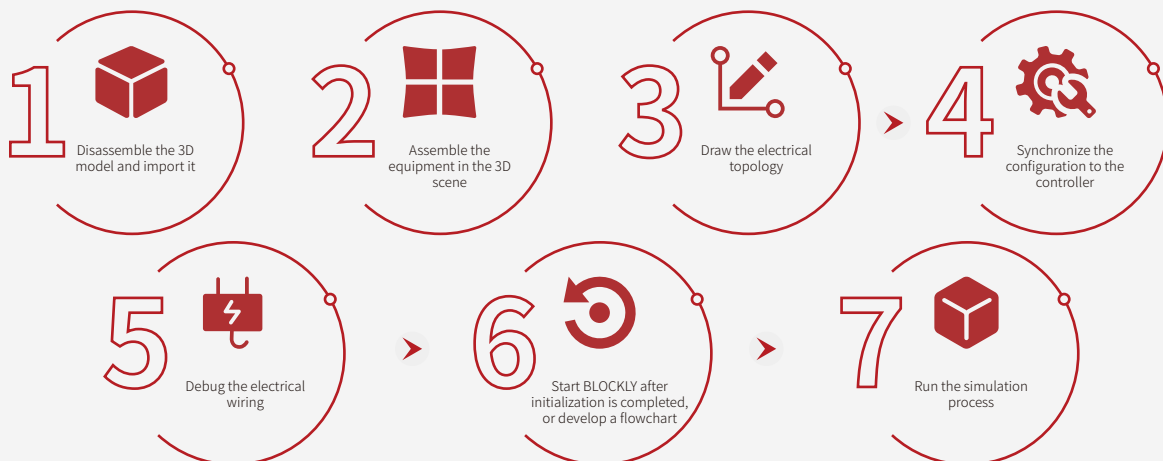

Differences with Traditional PLC



Traditional PLC system hardware topology

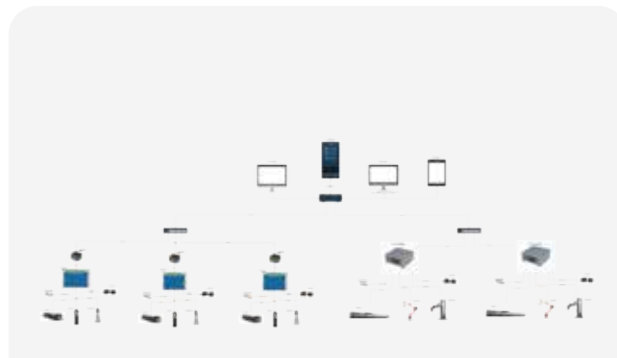

Hitbot OS Automatic System

Traditional Programming Problems and Hitbot Solutions

	Difficulties of current programming	HITBOT OS Solutions
Hardware requirement	Involving various types of hardware devices and communication protocols, you need to have a sufficient understanding of the working principles and functions of the hardware in order to correctly select and configure the hardware devices.	The integrated platform has a rich device library that covers various types and specifications of equipment. Engineers can directly call the equipment without spending a lot of time searching for and adapting the equipment.
Complex programming language	The programming language is very different from the traditional high-level programming language, such as the use of logic diagrams, function diagrams, structured text, etc. For beginners, it is difficult to learn and understand these programming languages.	The platform does not require any code and uses a graphical programming method that is intuitive, easy to understand, and simple to operate. Even if you have no programming experience, you can easily get started and operate it.
Complicated logic control	Programming involves a lot of logical control, which requires analysis and design of complex logical relationships. For some special application scenarios, such as complex calculations and algorithm requirements, it is necessary to respond flexibly to improve the efficiency and accuracy of programming.	It can quickly integrate resources according to user-specific needs and unique scenarios, and replace the programming of many modeling tasks through standardized robot control language and visual workflow, making machine motion programs simple, and designing, optimizing and verifying layouts faster and easier.
Difficult for debugging	During the programming process, many errors can only be discovered during actual operation, which requires engineers to have superb debugging skills and experience. When problems occur, error logs and debugging tools are needed to analyze and solve the problems.	What you see is what you get. By simply dragging modules, you can quickly complete wiring and device debugging. You can connect the wires according to the wiring diagram debugged on the platform.



4 Axis Robotic Arm

We are the pioneer of direct-drive robotic arms, and the arm has the characteristics of high precision, small size, more flexible rotation with internal arms, etc. The product is highly integrated, with an integrated design, no external control box, the Z-axis height can be customized, and it also supports upside-down deployment and other unique advantages.



6 Axis Robotic Arm

It helps enterprises to easily realize automation, and has the characteristics of high precision, large payload, and high integration. The product adopts drag-to-teach and graphical programming, as well as collision detection and customized collision level to lower the operating threshold and facilitate application in various industries.



End Effector

It helps enterprises to easily realize automation, and has the characteristics of high precision, large payload, and high integration. The product adopts drag-to-teach and graphical programming, as well as collision detection and customized collision level to lower the operating threshold and facilitate application in various industries.



Intelligent Actuator

The extremely cost-effective intelligent actuator eliminates the coupling, highly integrated external motor and controller, and maximizes the utilization of space and stroke.

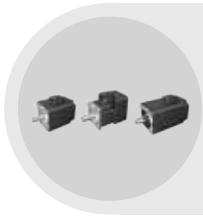

Integrated low-voltage servo motor

Strong power, excellent performance, our motors provide you with an unparalleled operating experience, using innovative technology, stable and durable. Choose our motors to make the power stronger and work more efficiently.



4-Axis Robotic Arm Controller

Hitbot four-axis robotic arm controller is precise, intelligent, efficient and stable. It can easily handle various complex tasks, help enterprises realize automated production, improve efficiency, and lead the new trend of intelligent manufacturing.

6-Axis Robotic Arm Controller

Hitbot six-axis robotic arm controller is intelligent, precise, efficient and stable. It can easily handle complex operations, help enterprises automate production, and start a new journey of intelligent manufacturing.



Multi-axis I/O Controller

Hitbot multi-axis I/O controller seamlessly connects to various equipments. It is compact and easy to install, simple to maintain and cost-effective.



Central Controller

With excellent computing power and precise control strategies, it can easily control complex automation processes.



Rich module

Hundreds of thousands of combinations are available, ready to use.



Various interface configurations

User connectors, gas circuit interfaces and network communication interfaces are reserved.



Reliable quality assurance

Embedded modules, precision reducers, whole machine repeat positioning accuracy detection, trajectory accuracy detection.



Diverse application fields

Automobile, photovoltaic, lithium battery, 3C, biomedicine and home appliances and other industries.



Authoritative Certification

Hitbot has passed many domestic and international authoritative certifications, such as CE, FCC, etc., leading the industry development with excellent quality.



Hitbot Intelligent Manufacturing Factory

Advanced equipment and professional team are perfectly combined to create high-quality products and help the development of enterprises.

Hitbot OS Platform Controller

4 Axis Controller(Z-CTR-SCR-NOR)



Specification

Items	Specification
Controller power supply	24V~48V
Communication	MQTT、Modbus_TCP、OPC-UA
Development environment	Windows/Linux/Mac/Android/iOS
LAN	1
WAN	1
Dimension	196*106*39mm
Device weight	435g (Without wire)
Material	Galvanized sheet
Working temperature	0-45°C
Working humidity	90%RH

6-Axis Controller(Z-CTR-ROB-ECT)



Specification

Items	Specification
Protection level	IP20
Outside the control box (I/O terminal)	Digital input(DI) 16 Digital output (DO) 16
	Analog input (AI) 2 Analog output (AO) 2
	USB*2
	HDMI*1
Controller power supply	220V/50Hz
Communication	MQTT、Modbus_TCP、OPC-UA
External expansion axis	EtherCAT expansion
Development environment	Windows/Linux/Mac/Android/iOS
Dimension	340×260×80 mm
Device weight	5kg(Without wire)
Material	Galvanized sheet
Working temperature	0-45°C
Operating humidity	90%RH

Multi-axis Controller(H-OS-AXI-ECT)



Specification

Items	Specification
Controller power supply	24V~48V
Communication	MQTT、Modbus_TCP、OPC-UA
Development environment	Windows/Linux/Mac/Android/iOS
LAN	1
WAN	1
Dimension	196*106*39mm
Device weight	435g (Without wire)
Material	Galvanized sheet
Working temperature	0-45°C
Working humidity	90%RH
WAN	1
Dimension	196*106*39mm
Device weight	435g (Without wire)
Material	Galvanized sheet
Working temperature	0-45°C
Working humidity	90%RH

Central Controller(H-OS-CTR-ARM)



H-OS-CTR-ARM is the HITBOT OS central controller. It is equipped with an octa-core 64-bit CPU with a main frequency of up to 2.4GHz, an integrated ARM Mali-G610 MP4 quad-core GPU, and a built-in AI accelerator NPU, which can provide 6TOPS computing power.

Specification

Items	Specification
CPU	Quad-core Cortex-A76 and Quad-core Cortex-A55
GPU	Mali-G610 MP4 (4x256KB L2 Cache)
RAM	8GB LPDDR4X
ROM	32GB EMMC
WAN	1 x 2.5G Ethernet
LAN	1 x 1000M Ethernet
USB3.0	x 2
HDMI OUT	x 1
power supply	24V~55V
OS system	Linux
weight	305g (Without wire)
Dimension	117*105*28mm
Working temperature	0-45°C
Working humidity	90%RH

- (1) Built-in full version of HITBOT OS.
- (2) Supports all device control drivers in the HITBOT OS device library.
- (3) Supports HDMI output.
- (4) Supports USB3.0 interface.

- (5) Supports dual Gigabit wired network ports and 2.4G/5G dual-band Wi-Fi (optional).
- (6) Supports multiple operating systems: Linux Debian&buildroot
- (7) Built-in watchdog and RTC battery, supporting 7*24 hours stable operation.

Robotic Arm Series

The Z-Arm is a revolutionary lightweight collaborative robot that dares to overturn industry standards and uses a built-in drive/control method.



Z-Arm XX32

Z-Arm XX42

Z-Arm XX42B

Z-Arm XX42E

Z-Arm XX50

Z-Arm XX60

Z-Arm XX60B



Z-Arm S622

Z-Arm S922

Z-Arm S1400

Z-Arm S1034

Z-Arm S1854

Collaboration and Safety

For processes that require high flexibility, tactile sensing, and flexibility, traditional robotic arms are difficult and expensive to implement. Human-robot collaboration is more efficient, and with unique collaborative functions, it can safely collaborate with humans without isolation fencing.

Quick Changeover

Especially suitable for flexible production of small batches and multiple categories that require frequent line changes. Flexible reorganization and easy adjustment of production stations.

Extremely Space-Saving

Small arms, stacking operation space is essential. Built-in drive/control body design

Superior Cost Performance

Superior cost performance compared to linear module replacement.

Simple and Easy to Use

Even if you don't know anything about robotic arms, you can learn to use it in 5 minutes because of its simple operation. Open Interface

Custom Z-Axis

Tailor-made for vertical travel.

Model Definition

Standard Model

Z-Arm T1832C0-T-FXXX-01

T	18	32	C	0	T	FXXX-01
Blank: Four-axis F: Five-axis T: Three-axis	Z-axis stroke For example, 180, the value here is 18	Arm Length For example, 320, the value here is 32	C: Cooperative C N: Non-cooperative	0: Silver 1: Black	Empty: Standard version T: Inverted version	F: Customization option, if it is a standard product, it is blank XXX: Customer number 01: Version number

Z-Arm T2442C0-A0M1-T-FXXX-01

T	24	42	C	0	A0	M1	T	FXXX-01
Blank: Four-axis F: Five-axis T: Three-axis	Z-axis stroke For example, 210, the value here is 21 For example, 240, the value here is 24	42: Arm length 420, with synchronized Z-axis belt 42E: Arm length 420, with Z-axis module	C: Cooperative C N: Non-cooperative	0: Silver 1: Black	A0: Two straight-through wires A2: Two air pipes	M1: Second arm body movement range $\pm 164\text{deg}$ (external rotation) M2: Second arm body movement range 15deg-345deg (internal rotation)	Empty: Standard version T: Inverted version	F: Customization option, if it is a standard product, it is blank XXX: Customer number 01: Version number

High-end Model

Z-Arm T2442BN0-A0M1-T-FXXX-01

T	24	42	B	N	0	A0	M1	T	FXXX-01
Blank: Four-axis F: Five-axis T: Three-axis	Z-axis stroke For example, 240, the value here is 24	42: Arm length 420	B: Advanced version	C: Cooperative C N: Non-cooperative	0: Silver 1: Black	A0: Two straight-through wires A2: Two air pipes	M1: Second arm body movement range $\pm 164\text{deg}$ (external rotation) M2: Second arm body movement range 15deg-345deg (internal rotation)	Empty: Standard version T: Inverted version	F: Customization option, if it is a standard product, it is blank XXX: Customer number 01: Version number

Z-Arm T4150N0-A0M1-T-FXXX-01

T	41	50	N	0	A0	M1	T	FXXX-01
Blank: Four-axis F: Five-axis T: Three-axis	Z-axis stroke For example, 410, the value here is 41	50: Arm length 500	C: Cooperative C N: Non-cooperative	0: Silver 1: Black	A0: Two straight-through wires A2: Two air pipes	M1: Second arm body movement range $\pm 164\text{deg}$ (external rotation) M2: Second arm body movement range 15deg-345deg (internal rotation)	Empty: Standard version T: Inverted version	F: Customization option, if it is a standard product, it is blank XXX: Customer number 01: Version number

Z-Arm T4160BN0-A0M1-T-FXXX-01

T	41	60	B	N	A0	M1	T	FXXX-01
Blank: Four-axis F: Five-axis T: Three-axis	Z-axis stroke For example, 410, the value here is 41	60: Arm length 600	B: The advanced version Empty: Standard Edition	C: Cooperative C N: Non-cooperative	A0: Two straight-through wires A2: Two air pipes	M1: Second arm body movement range $\pm 164\text{deg}$ (external rotation) M2: Second arm body movement range 15deg-345deg (internal rotation)	Empty: Standard version T: Inverted version	F: Customization option, if it is a standard product, it is blank XXX: Customer number 01: Version number

Specifications



Four-axis Collaborative Robots

Item		Z-Arm XX32	Z-Arm XX42
Basic Information	1-axis arm length	160mm	220mm
	1-axis rotation angle	±90°	±90°
	2-axis arm length	160mm	200mm
	2-axis rotation angle	±143°	±164° (Optional: 15°~345°)
	Z-axis stroke	180mm (Height customizable)	240mm (Height customizable)
	R-axis rotation range	±1080°	±1080°No mechanical limit / ±170°With mechanical limit
Linear speed		1017mm/s (Payload 0.5kg)	1220mm/s (Payload 2kg)
Repeatability		±0.02mm	±0.03mm
Standard payload		0.5kg	2kg
Maximum payload		1kg	3kg
Degrees of freedom		4	4
Power supply		220V/110V50-60HZ adapted to DC24V peak power 320W	220V/110V50-60HZ adapted to DC24V peak power 500W
Communication		Ethernet	Ethernet
Z-axis height can be customized		0.1~0.5m	0.1~1m
Electrical reserved interface		/	Standard: Socket panel straight through small arm lower cover plate, 2 pieces of 4*23awg (unshielded) wire Optional: Socket panel straight through flange, 2 pieces of φ4 air pipe
Optional accessories		Z-EFG-8S/Z-EFG-12/Z-EFG-20/Z-EFG-20S	Z-EFG-8S/Z-EFG-12/Z-EFG-20/Z-EFG-20S/Z-EFG-30/Z-EFG-50, 5th axis, 3D printing
Working environment		Temperature: 0~45°C Humidity: 20~80%RH (non-condensing)	Temperature: 0~45°C Humidity: 20~80%RH (non-condensing)
I/O port digital quantity input (isolation)		9+3	9+3+arm extension (8 in and 8 out; gripper dedicated port: pulse or 485)
I/O port digital quantity output (isolation)		9+3	9+3+arm extension (8 in and 8 out; gripper dedicated port: pulse or 485)
I/O port analog quantity input (4-20mA)		/	/
I/O port analog quantity output (4-20mA)		/	/
Overall height		500mm	596mm
Machine weight		180mm stroke net weight is about 11kg	240mm stroke net weight is about 19kg
Base outline size		200*200*10mm	200*200*10mm
Base fixing hole spacing		160*160mm equipped with four M5*12 screws	160*160mm equipped with four M8*20 screws
Collision detection		✓	✓
Drag teaching		✓	✓
Hardware emergency stop		✓	✓
Debugging/Online upgrading (USB port)		✓	✓
Chassis compatibility		Fully compatible with Z-Arm 1632	/
Flange compatibility		Compatible with Z-Arm 1632 flange	Compatible with Z-Arm 2140 flange

Note: As the product continues to be updated and iterated upon, if there are any changes to the product parameters, we will not notify separately.



Z-Arm XX42B

Z-Arm XX42E

Z-Arm XX50

220mm	220mm	275mm
±90°	±90°	±90°
200mm	200mm	225mm
±164° (Optional: 15°~345°)	±164° (Optional: 15°~345°)	±164° (Optional: 15°~345°)
240mm (Height customizable)	210mm (Height customizable)	410mm (Height customizable)
±1080°No mechanical limit / ±170°With mechanical limit	±1080° No mechanical limit / ±170° With mechanical limit	±1080° No mechanical limit / ±170° With mechanical limit
1600mm/s (Payload4kg)	1220mm/s (Payload 2kg)	1400mm/s (Payload 4kg)
±0.03mm	±0.03mm	±0.05mm
4kg	2kg	4kg
5kg	3kg	5kg
4	4	4
220V/110V50-60HZ adapted to DC48V peak power 2000W	220V/110V50-60HZ adapted to DC24V peak power 500W	220V/110V50-60HZ adapted to DC48V peak power 960W
Ethernet	Ethernet	Ethernet
0.1~0.5m	0.11m、0.21m、0.31m、0.41m、0.51m	0.1~1m
Standard: Socket panel straight through small arm lower cover plate, 2 pieces of 4*23awg (unshielded) wire Optional: Socket panel straight through flange, 2 pieces of φ4 air pipe	Standard: Socket panel straight through small arm lower cover plate, 2 pieces of 4*23awg (unshielded) wire Optional: Socket panel straight through flange, 2 pieces of φ4 air pipe	Standard: Socket panel straight through small arm lower cover plate, 2 pieces of 4*23awg (unshielded) wire Optional: Socket panel straight through flange, 2 pieces of φ4 air pipe
E-EFG-8S/Z-EFG-12/Z-EFG-20/Z-EFG-20S/Z-EFG-20F/Z-ERG-20C/Z-EFG-30/Z-EFG-50/Z-EFG-100	Z-EFG-8S/Z-EFG-12/Z-EFG-20/Z-EFG-20S/Z-EFG-30/Z-EFG-50, 5th axis, 3D printing	Z-EFG-8S/Z-EFG-12/Z-EFG-20/Z-EFG-20S/Z-EFG-20F/Z-ERG-20C/Z-EFG-30/Z-EFG-50/Z-EFG-100, 5th axis, 3D printing
Temperature: 0~45°C Humidity: 20~80%RH (non-condensing)	Temperature: 0~45°C Humidity: 20~80%RH (non-condensing)	Temperature: 0~45°C Humidity: 20~80%RH (non-condensing)
9+3+arm extension (8 in and 8 out; gripper dedicated port: pulse or 485)	9+3+arm extension (8 in and 8 out; gripper dedicated port: pulse or 485)	9+3+arm extension (8 in and 8 out; gripper dedicated port: pulse or 485)
9+3+arm extension (8 in and 8 out; gripper dedicated port: pulse or 485)	9+3+arm extension (8 in and 8 out; gripper dedicated port: pulse or 485)	9+3+arm extension (8 in and 8 out; gripper dedicated port: pulse or 485)
/	/	/
/	/	/
683mm	566mm	830mm
240mm stroke net weight is about 27kg	240mm stroke net weight is about 18kg	240mm stroke net weight is about 28kg
250*250*15mm	200*200*10mm	250*250*15mm
200*200mm equipped with four M8*20 screws	160*160mm equipped with four M8*20 screws	200*200mm equipped with four M8*20 screws
/	✓	/
/	✓	✓
✓	✓	✓
✓	✓	✓
Fully compatible with Z-Arm XX60	Fully compatible with Z-Arm XX42	Fully compatible with Z-Arm XX60
Compatible with Z-Arm XX60 flange	Compatible with Z-Arm 2140 flange	Compatible with Z-Arm XX42 flange



Four-axis Collaborative Robots

Item		Z-Arm XX60	Z-Arm XX60B
Basic Information	1-axis rotation arm length	325mm	325mm
	1-axis rotation angle	±90°	±90°
	2-axis arm length	275mm	275mm
	2-axis rotation angle	±164° (Optional: 15°~345°)	±164° (Optional: 15°~345°)
	Z-axis stroke	410mm (Height customizable)	410mm (Height customizable)
	R-axis rotation range	±1080° No mechanical limit / ±170° With mechanical limit	±1080° No mechanical limit / ±170° With mechanical limit
Linear speed		1500mm/s (Payload 3kg)	2000mm/s (Payload 4kg)
Repeatability		±0.05mm	±0.02mm
Standard payload		3kg	4kg
Maximum payload		3.5kg	5kg
Degrees of freedom		4	4
Power supply		220V/110V50-60HZ adapted to DC48V peak power 960W	220V/110V50-60HZ adapted to DC48V peak power 2000W
Communication		Ethernet	Ethernet
Z-axis height can be customized		0.1~1m	0.1~0.8m
Electrical reserved interface		Standard: Socket panel straight through small arm lower cover plate, 2 pieces of 4*23awg (unshielded) wire Optional: Socket panel straight through flange, 2 pieces of φ4 air pipe	Standard: Socket panel straight through small arm lower cover plate, 2 pieces of 4*23awg (unshielded) wire Optional: Socket panel straight through flange, 2 pieces of φ4 air pipe
Optional accessories		Z-EFG-8S/Z-EFG-12/Z-EFG-20/Z-EFG-20S/Z-EFG-20F/Z-ERG-20C/Z-EFG-30/ Z-EFG-50/Z-EFG-100, 5th axis, 3D printing	Z-EFG-8S/Z-EFG-12/Z-EFG-20/Z-EFG-20S/Z-EFG-20F/Z-ERG-20C/ Z-EFG-30/Z-EFG-50/Z-EFG-100
Working environment		Temperature: 0~45°C Humidity: 20~80%RH (non-condensing)	Temperature: 0~45°C Humidity: 20~80%RH (non-condensing)
I/O port digital quantity input (isolation)		9+3+arm extension (8 in and 8 out; gripper dedicated port: pulse or 485)	9+3+arm extension (8 in and 8 out; gripper dedicated port: pulse or 485)
I/O port digital quantity output (isolation)		9+3+arm extension (8 in and 8 out; gripper dedicated port: pulse or 485)	9+3+arm extension (8 in and 8 out; gripper dedicated port: pulse or 485)
I/O port analog quantity input (4-20mA)		/	/
I/O port analog quantity output (4-20mA)		/	/
Overall height		830mm	860mm
Machine weight		410mm stroke net weight is about 28kg	410mm stroke net weight is about 36.5kg
Base outline size		250*250*15mm	250*250*15mm
Base fixing hole spacing		200*200mm equipped with four M8*20 screws	200*200mm equipped with four M8*20 screws
Collision detection		/	/
Drag teaching		✓	/
Hardware emergency stop		✓	✓
Debugging/Online upgrade (USB port)		✓	✓
Chassis compatibility		/	Fully compatible with Z-Arm XX60
Flange compatibility		Fully compatible with Z-Arm XX42	Compatible with Z-Arm XX42 flange

Note: As the product continues to be updated and iterated upon, if there are any changes to the product parameters, we will not notify separately.



Six-axis Cobots

Item	Z-Arm S622	Z-Arm S922	Z-Arm S1400
Weight	≈15kg	≈22kg	≈40kg
Effective Payload	3kg	5kg	10kg
Working Radius	622mm	922mm	1400mm
Joint range of motion Software limits	1 Axis: ±175° 2 Axis: +85°, -265° 3 Axis: ±150° 4 Axis: +85°, -265° 5 Axis: ±175° 6 Axis: ±175°	1 Axis: ±175° 2 Axis: +85°, -265° 3 Axis: ±160° 4 Axis: +85°, -265° 5 Axis: ±175° 6 Axis: ±175°	1 Axis: ±175° 2 Axis: +85°, -265° 3 Axis: ±160° 4 Axis: +85°, -265° 5 Axis: ±175° 6 Axis: ±175°
Typical TCP Speed	1m/s	1m/s	1m/s
Repeatability	±0.02mm	±0.02mm	±0.05mm
Installation Area	φ128mm	φ149mm	φ190mm
Mounting Direction	Vertical, Horizontal, Inverted	Vertical, Horizontal, Inverted	Vertical, Horizontal, Inverted
Control Box Size	342*260*90mm (No bumps)	342*260*90mm (No bumps)	342*260*90mm (No bumps)
Degree of Freedom	6	6	6
Control Box I/O Ports	Digital Input: 16 Digital Output: 16 Analog input: 2 Analog output: 2	Digital Input: 16 Digital Output: 16 Analog input: 2 Analog output: 2	Digital Input: 16 Digital Output: 16 Analog input: 2 Analog output: 2
End I/O Ports	Analog input: 1 Analog output: 1 Digital Input: 2 Digital Output: 2	Analog input: 1 Analog output: 1 Digital Input: 2 Digital Output: 2	Analog input: 1 Analog output: 1 Digital Input: 2 Digital Output: 2
I/O Power	24V/1.5A	24V/1.5A	24V/1.5A
Communication	I/O, TCP/IP, Modbus_TCP/RTU, Profinet	I/O, TCP/IP, Modbus_TCP/RTU, Profinet	I/O, TCP/IP, Modbus_TCP/RTU, Profinet
Development Environment	C#/C++/Python/java/ROS	C#/C++/Python/java/ROS	C#/C++/Python/java/ROS
Noise	<65dB	<65dB	<65dB
Protection level	IP54	IP54	IP54
Coordinated Operation	Equipped with collision detection, allowing for custom collision levels	Equipped with collision detection, allowing for custom collision levels	Equipped with collision detection, allowing for custom collision levels
Power supply	220V/50HZ	220V/50HZ	220V/50HZ
Working environment	<ul style="list-style-type: none"> Keep away from corrosive gases, liquids and explosive gases Avoid operating the equipment under unstable current conditions Keep away from vibrations, and vibration intensity should not exceed 0.5G Avoid dust, smoke, and water 	<ul style="list-style-type: none"> Keep away from corrosive gases, liquids and explosive gases Avoid operating the equipment under unstable current conditions Keep away from vibrations, and vibration intensity should not exceed 0.5G Avoid dust, smoke, and water 	<ul style="list-style-type: none"> Keep away from corrosive gases, liquids and explosive gases Avoid operating the equipment under unstable current conditions Keep away from vibrations, and vibration intensity should not exceed 0.5G Avoid dust, smoke, and water
Temperature Range	0~45°C	0~45°C	0~45°C
Humidity Range	20~80%RH (non-condensing)	20~80%RH (non-condensing)	20~80%RH (non-condensing)
Outlet specifications	Cable length 3.7m	Cable length 3.7m	Cable length 3.7m



Six-axis Cobots

Item	Z-Arm S1034	Z-Arm S1854
Weight	≈40kg	≈85kg
Effective Payload	16kg	20kg
Working Radius	1034mm	1854mm
Joint range of motion Software limits	1 Axis: ±175° 2 Axis: +85°, -265° 3 Axis: ±160° 4 Axis: +85°, -265° 5 Axis: ±175° 6 Axis: ±175°	1 Axis: ±175° 2 Axis: +85°, -265° 3 Axis: ±160° 4 Axis: +85°, -265° 5 Axis: ±175° 6 Axis: ±175°
Typical TCP Speed	1m/s	2m/s
Repeatability	±0.05mm	±0.1mm
Installation Area	φ190mm	φ240mm
Mounting Direction	Vertical, Horizontal, Inverted	Vertical, Horizontal, Inverted
Control Box Size	342*260*90mm (No bumps)	342*180*44.5mm (No bumps)
Degree of Freedom	6	6
Control Box I/O Ports	Digital Input: 16 Digital Output: 16 Analog input: 2 Analog output: 2	Digital Input: 16 Digital Output: 16 Analog input: 2 Analog output: 2
End I/O Ports	Analog input: 1 Analog output: 1 Digital Input: 2 Digital Output: 2	Analog input: 1 Analog output: 1 Digital Input: 2 Digital Output: 2
I/O Power	24V/1.5A	24V/1.5A
Communication	I/O, TCP/IP, Modbus_TCP/RTU, Profinet	I/O, TCP/IP, Modbus_TCP/RTU, Profinet
Development Environment	C#/C++/Python/java/ROS	C#/C++/Python/java/ROS
Noise	<65dB	<70dB
Protection level	IP54	IP54
Coordinated Operation	Equipped with collision detection, allowing for custom collision levels	Equipped with collision detection, allowing for custom collision levels
Power supply	220V/50HZ	220V/50HZ
Working environment	<ul style="list-style-type: none"> · Keep away from corrosive gases, liquids and explosive gases · Avoid operating the equipment under unstable current conditions · Keep away from vibrations, and vibration intensity should not exceed 0.5G · Avoid dust, smoke, and water 	<ul style="list-style-type: none"> · Keep away from corrosive gases, liquids and explosive gases · Avoid operating the equipment under unstable current conditions · Keep away from vibrations, and vibration intensity should not exceed 0.5G · Avoid dust, smoke, and water
Temperature Range	0-45°C	0-45°C
Humidity Range	20-80%RH (non-condensing)	20-80%RH (non-condensing)
Outlet specifications	Cable length 3.7m	Cable length 3.7m

Unique Features of 4-Axis Robot Arm

Integrated Motor Control, No Additional Wiring



- 1** Customizable height



- 2** Deployable in an inverted position

Note

The XX32 Z-axis can be customized to a height of 0.1-0.5m;

The XX42, XX50, and XX60 Z-axes can be customized to a height of 0.1-1m;

The XX42E Z-axis can be customized to a height of 0.11m, 0.21m, 0.31m, 0.41m, or 0.51m.

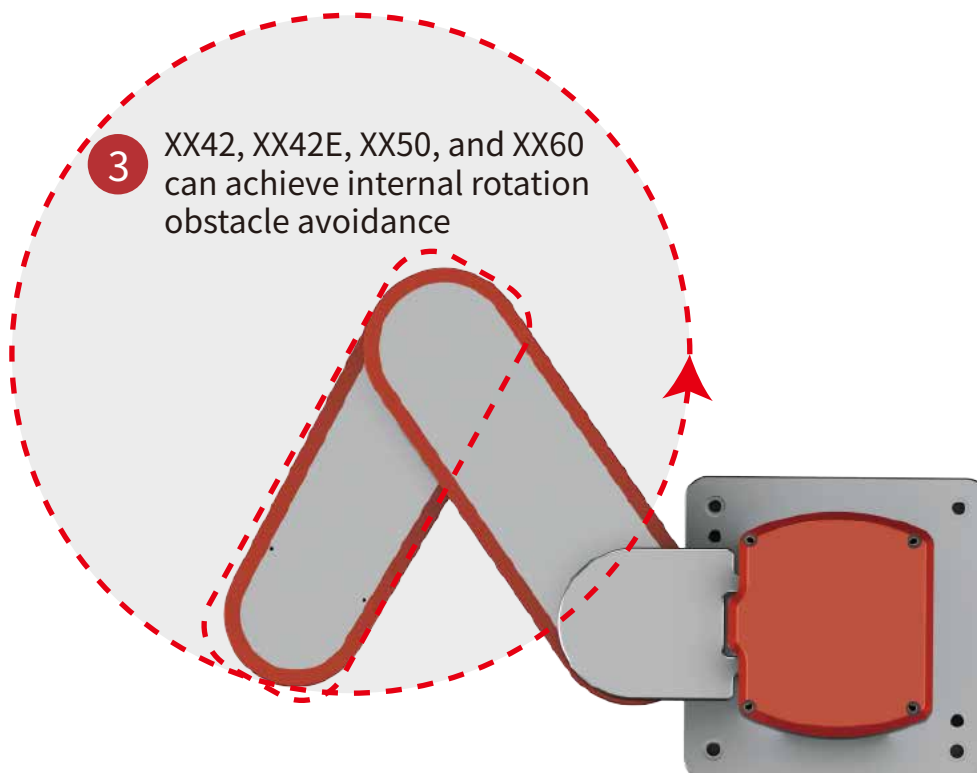

Z-Arm 1832/Z-Arm XX32



- High precision**
 Repeatability $\pm 0.02\text{mm}$
- Z-axis customization**
 0.1-0.5m
- Arm span**
 J1 Axis 160mm
 J2 Axis 160mm
- Cost-effective**
 Industrial-grade quality
 Competitive price

Range of motion and dimension

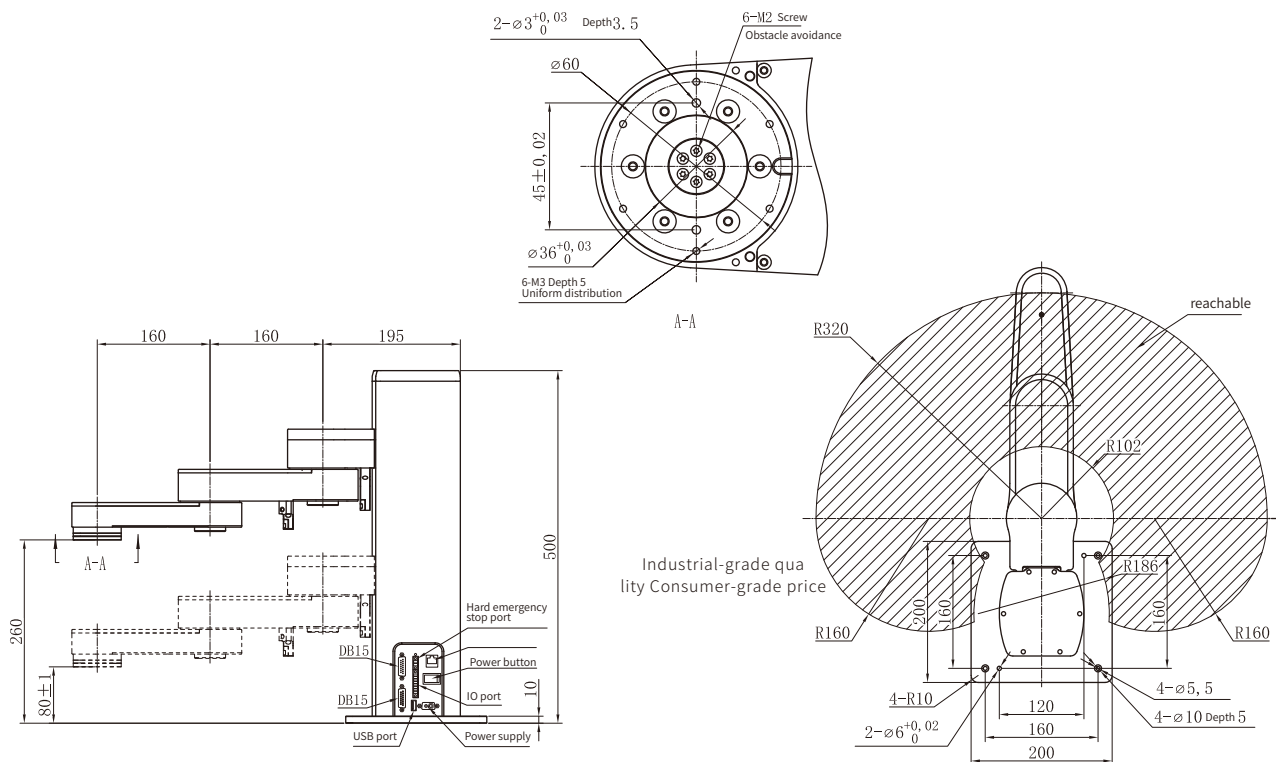

Note:

There is a cable below the arm of the machine, which is not shown in the figure, please refer to the real product
 Some hardware of the control panel of the robot arm is not shown in the figure, please refer to the real product.

Specifications

Item Z-Arm XX32	Parameters
1-axis arm length	160mm
1-axis rotation angle	±90°
2-axis arm length	160mm
2-axis rotation angle	±143°
Z-axis stroke	180mm (Height customizable)
R-axis rotation range	±1080°
Linear speed	1017mm/s (Payload0.5kg)
Repeatability	±0.02mm
Standard payload	0.5kg
Maximum payload	1kg
Degree of freedom	4
Power supply	220V/110V50-60HZ adapted to DC24V peak power 320W
Communication	Ethernet
Z-Axis can be customized in height	0.1~0.5m
Electrical reserved interface	/
Optional accessories	Z-EFG-8S/Z-EFG-12/Z-EFG-20/Z-EFG-20S
Working environment	Temperature: 0~45°C Humidity: 20~80%RH (non-condensing)
I/O port digital quantity input (Isolated)	9+3
I/O port digital quantity output (Isolated)	9+3
I/O port analog quantity input (4-20mA)	/
I/O port analog quantity output (4-20mA)	/
Machine height	500mm
Machine weight	180mm stroke net weight is about 11kg
Base external dimensions	200*200*10mm
Distance between base fixing holes	160*160mm equipped with four M8*20 screws
Collision detection	✓
Drag teaching	✓
Hard emergency stop	✓
Debugging/Online upgrading (USB port)	✓
Outlet specification	AC cable & DC cable:2 meters,can't use drag chain
Cycle time	2.28s

Z-Arm 2442/Z-Arm XX42



High precision

Repeatability $\pm 0.03\text{mm}$

Maximum payload

3kg

Arm span

J1 Axis 220mm
J2 Axis 200mm

Cost-effective

Industrial-grade quality
Competitive price

Integrated design of end effector



Range of motion and dimension

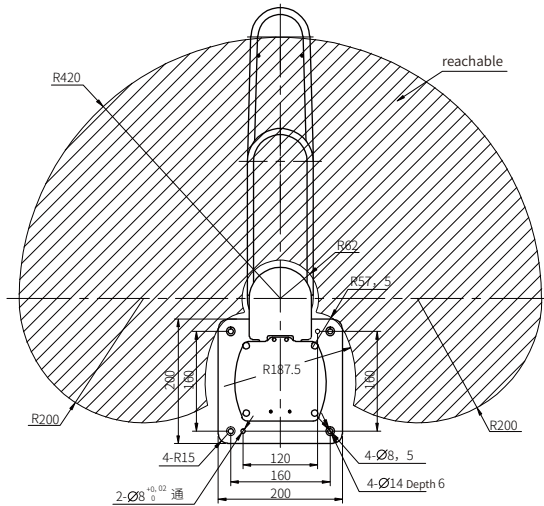

M1Version
(External rotation)

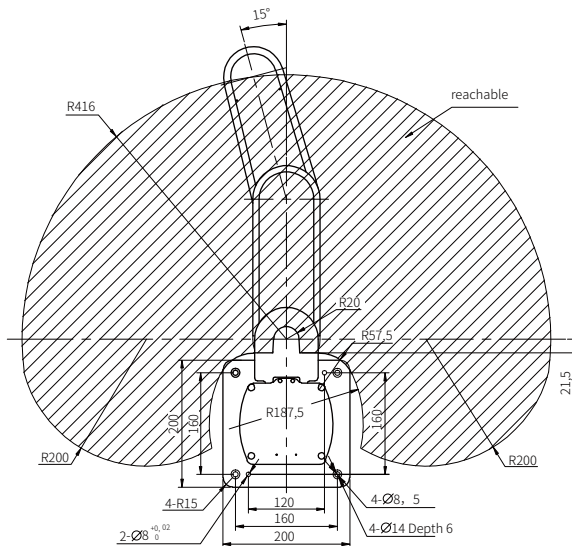
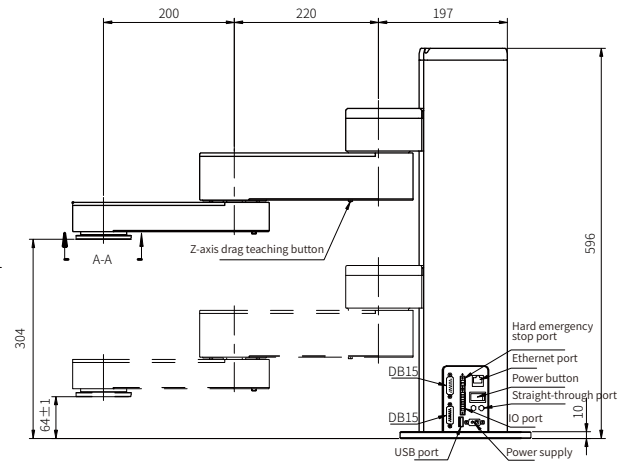

M2Version
(Internal rotation)

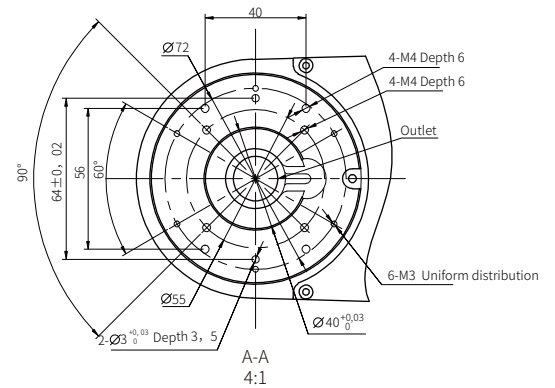

Note: Some hardware of the control panel of the robot arm is not shown in the figure, please refer to the real product.

Specifications

Item Z-Arm XX42	Parameters
1-axis arm length	220mm
1-axis rotation angle	±90°
2-axis arm length	200mm
2-axis rotation angle	±164° (Optional: 15°~345°)
Z-axis stroke	240 (Height customizable)
R-axis rotation range	±1080° No mechanical limit / ±170° With mechanical limit
Linear speed	1220mm/s (Payload 4kg)
Repeatability	±0.03mm
Standard payload	2kg
Maximum payload	3kg
Degree of freedom	4
Power supply	220V/110V50-60HZ adapted to DC48V peak power 2000W
Communication	Ethernet
Z-Axis can be customized in height	0.1~1m
Electrical reserved interface	Standard: Socket panel straight through small arm lower cover plate, 2 pieces of 4*23awg (unshielded) wire Optional: Socket panel straight through flange, 2 pieces of φ4 air pipe
Optional accessories	E-EFG-8S/Z-EFG-12/Z-EFG-20/Z-EFG-20S/Z-EFG-20F/ Z-ERG-20C/Z-EFG-30/Z-EFG-50/Z-EFG-100
Working environment	Temperature: 0~45°C Humidity: 20~80%RH (non-condensing)
I/O port digital quantity input (Isolated)	9+3+arm extension (8 in and 8 out; gripper dedicated port: pulse or 485)
I/O port digital quantity output (Isolated)	9+3+arm extension (8 in and 8 out; gripper dedicated port: pulse or 485)
I/O port analog quantity input (4-20mA)	/
I/O port analog quantity output (4-20mA)	/
Machine height	596mm
Machine weight	240mm stroke net weight is about 19kg
Base external dimensions	200*200*10mm
Distance between base fixing holes	160*160mm equipped with four M8*20 screws
Collision detection	✓
Drag to teach	✓
Hard emergency stop	✓
Debugging/Online upgrading (USB port)	✓
Outlet specification	AC cable & DC cable:2 meters
Cycle time	2.066s

Z-Arm 2442B/Z-Arm XX42B



High precision

Repeatability $\pm 0.02\text{mm}$

Maximum payload

5kg

Arm span

J1 Axis 220mm

J2 Axis 200mm

Cost-effective

Industrial-grade quality

Competitive price

Integrated design of end effector



Range of motion and dimension

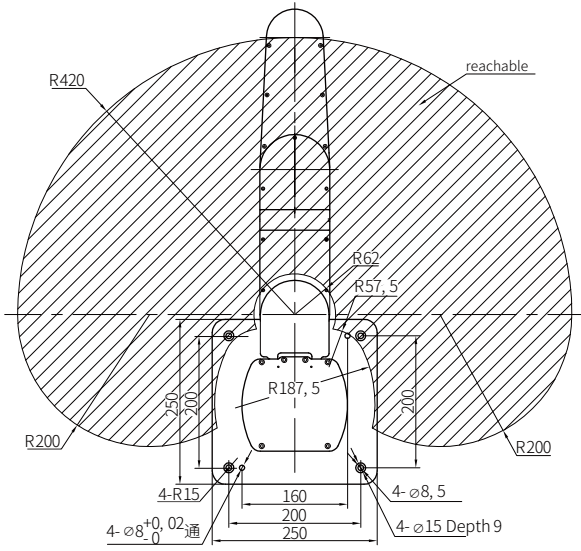

M1Version
(External rotation)

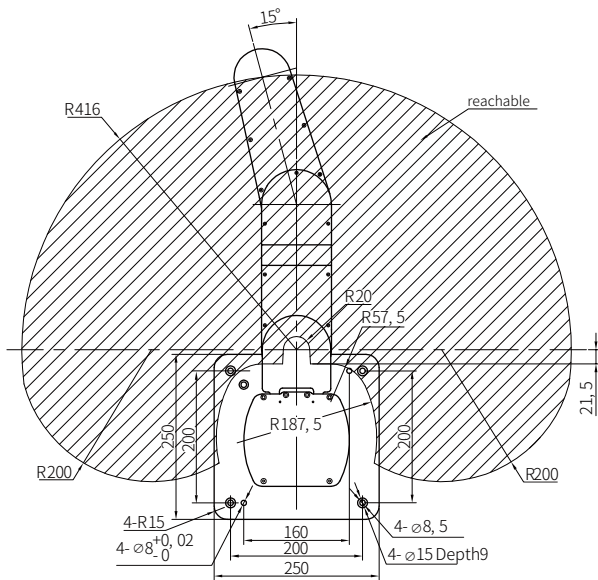
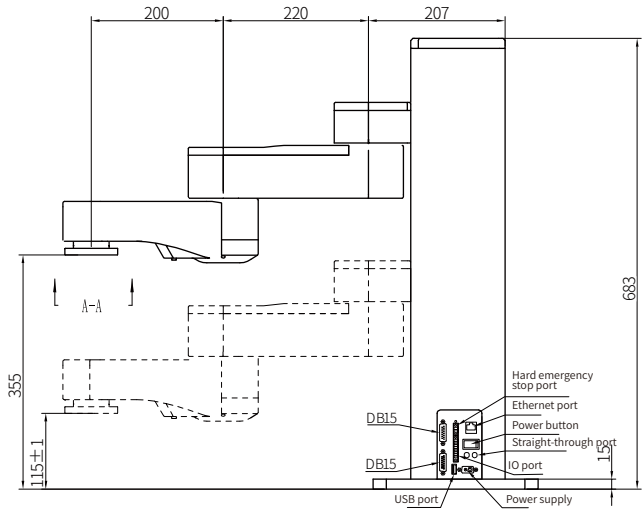

M2Version
(Internal rotation)

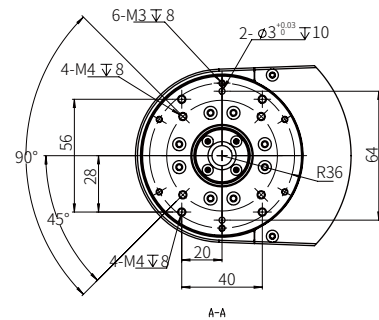

Note: Some hardware of the control panel of the robot arm is not shown in the figure, please refer to the real product.

Specifications

ItemZ-Arm XX42B	Parameters
1-axis arm length	220mm
1-axis rotation angle	±90°
2-axis arm length	200mm
2-axis rotation angle	±164° (Optional: 15°~345°)
Z-axis stroke	240 (Height customizable)
R-axis rotation range	±1080° No mechanical limit / ±170° With mechanical limit
Linear speed	1600mm/s (Payload 4kg)
Repeatability	±0.02mm
Standard payload	4kg
Maximum payload	5kg
Degree of freedom	4
Power supply	220V/110V50-60HZ adapted to DC48V peak power 960W
Communication	Ethernet
Z-Axis can be customized in height	0.1~0.5m
Electrical reserved interface	Standard: Socket panel straight through small arm lower cover plate, 2 pieces of 4*23awg (unshielded) wire Optional: Socket panel straight through flange, 2 pieces of φ4 air pipe
Optional accessories	Z-EFG-8S/Z-EFG-12/Z-EFG-20/Z-EFG-20S/Z-EFG-20F/Z-ERG-20C/Z-EFG-30/Z-EFG-50/Z-EFG-100, 5th axis, 3D printing
Working environment	Temperature: 0~45°C Humidity: 20~80%RH (non-condensing)
I/O port digital quantity input (Isolated)	9+3+arm extension (8 in and 8 out; gripper dedicated port: pulse or 485)
I/O port digital quantity output (Isolated)	9+3+arm extension (8 in and 8 out; gripper dedicated port: pulse or 485)
I/O port analog quantity input (4-20mA)	/
I/O port analog quantity output (4-20mA)	/
Machine height	683mm
Machine weight	240mm stroke net weight is about 27kg
Base external dimensions	250*250*15mm
Distance between base fixing holes	200*200mm equipped with four M8*20 screws
Collision detection	/
Drag teaching	/
Hard emergency stop	✓
Debugging/Online upgrading (USB port)	✓
Outlet specification	AC cable & DC cable:2 meters
Cycle time	1.895s

Z-Arm 2142E/Z-Arm XX42E



High precision

Repeatability $\pm 0.03\text{mm}$

Maximum payload

3kg

Arm span

J1 Axis 220mm
J2 Axis 200mm

Cost-effective

Industrial-grade quality
Competitive price

Integrated design of end effector



Range of motion and dimension

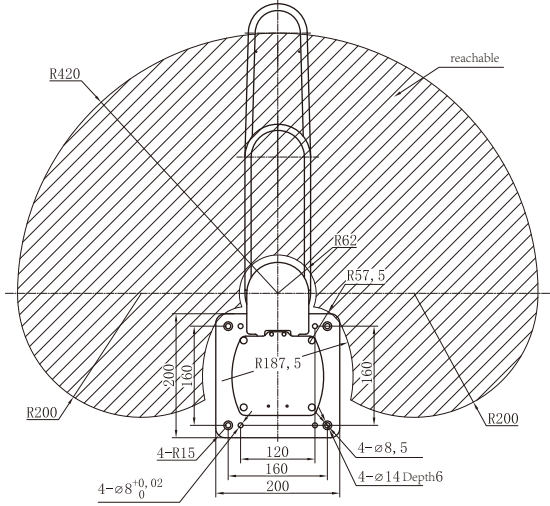

M1Version
(External rotation)

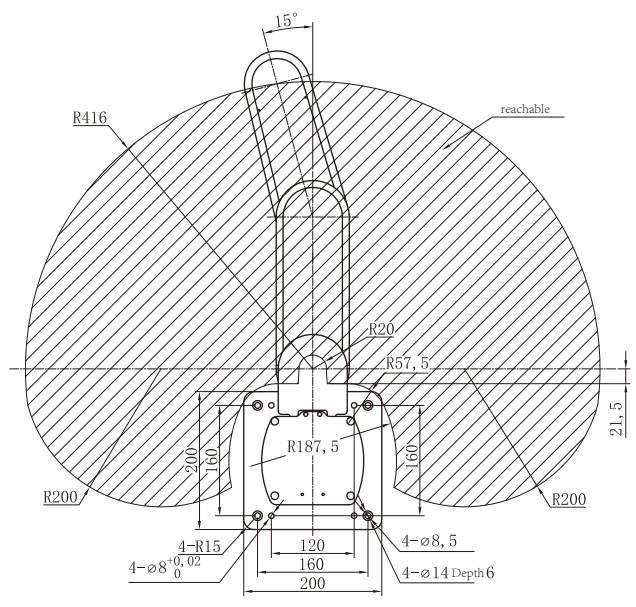
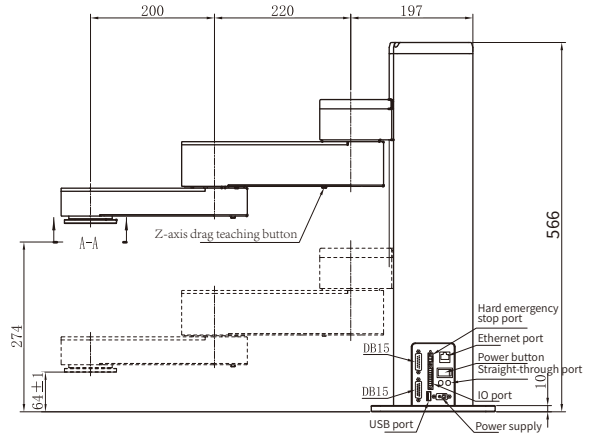

M2Version
(Internal rotation)

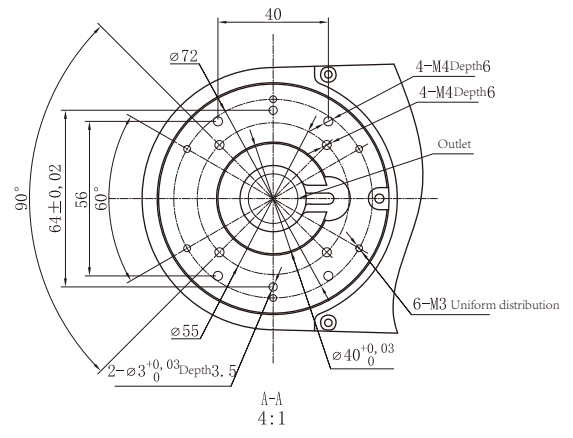

Note: Some hardware of the control panel of the robot arm is not shown in the illustration, please refer to the real product.

Specifications

Item Z-Arm-XX42E	Parameters
1-axis arm length	220mm
1-axis rotation angle	±90°
2-axis arm length	200mm
2-axis rotation angle	±164° (Optional: 15°~345°)
R-axis rotation range	210 (Height customizable)
Z-axis stroke	±1080° No mechanical limit / ±170° With mechanical limit
Standard payload	1220mm/s (Payload 2kg)
Linear speed	±0.03mm
Repeatability	2kg
Maximum payload	3kg
Degree of freedom	4
Power supply	220V/110V50-60HZ adapted to DC24V peak power 500W
Communication	Ethernet
Z-Axis can be customized in height	0.11m、0.21m、0.31m、0.41m、0.51m
Electrical reserved interface	Standard: Socket panel straight through small arm lower cover plate, 2 pieces of 4*23awg (unshielded) wire Optional: Socket panel straight through flange, 2 pieces of φ4 air pipe
Optional accessories	Z-EFG-8S/Z-EFG-12/Z-EFG-20/Z-EFG-20S/Z-EFG-30/ Z-EFG-50, 5th axis, 3D printing
Working environment	Temperature: 0~45°C Humidity: 20~80%RH (non-condensing)
I/O port digital quantity input (Isolated)	9+3+arm extension (8 in and 8 out; gripper dedicated port: pulse or 485)
I/O port digital quantity output (Isolated)	9+3+arm extension (8 in and 8 out; gripper dedicated port: pulse or 485)
I/O port analog quantity input (4-20mA)	/
I/O port analog quantity output (4-20mA)	/
Base external dimensions	566mm
Machine height	210mm stroke net weight is about 18kg
Machine weight	200*200*10mm
Distance between base fixing holes	160*160mm equipped with four M8*20 screws
Collision detection	✓
Hard emergency stop	✓
Drag teaching	✓
Debugging/Online upgrading (USB port)	✓
Outlet specification	AC cable & DC cable:2 meters
Cycle time	2.066s

Z-Arm 4150/Z-Arm XX50



High precision

Repeatability $\pm 0.05\text{mm}$

Customizable Z-Axis

0.1-1m

High payload

Standard payload 4 kg
Maximum payload 5 kg

Maximum speed

Standard payload 4 kg
line speed 1.4m/s

Cost-effective

Industrial-grade quality
Competitive price

Integrated design of end effector



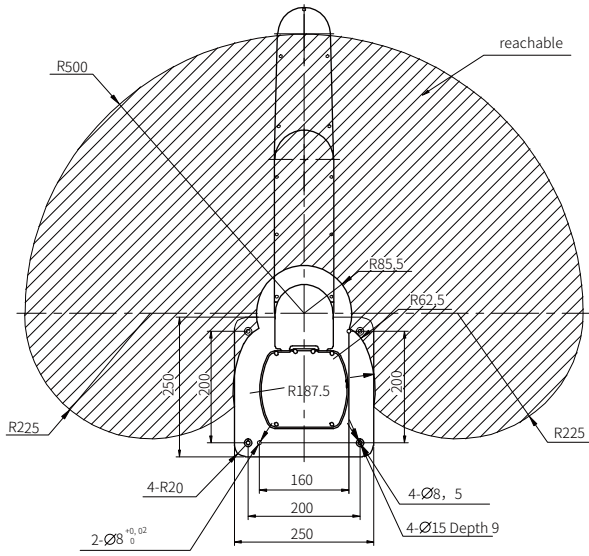

M1Version
(External rotation)

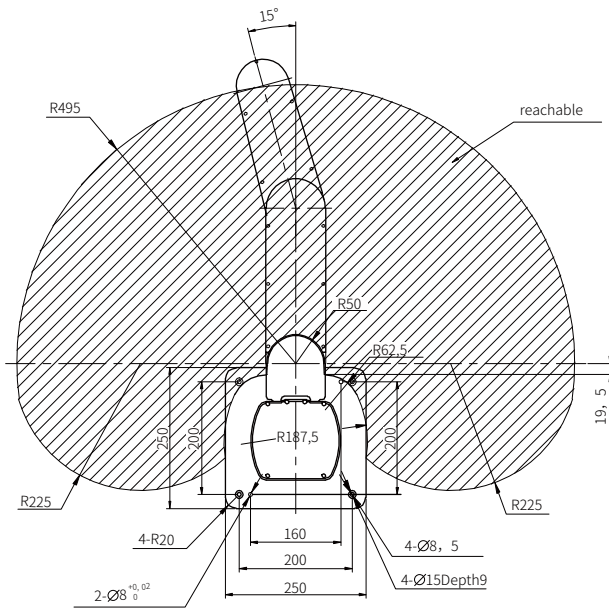
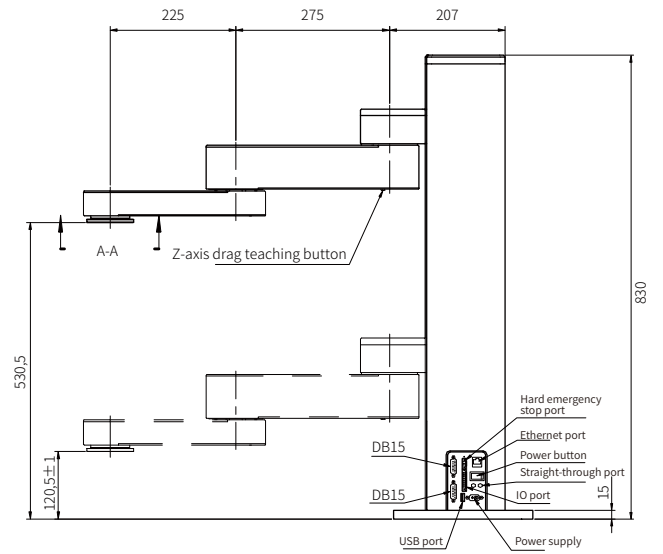

M2Version
(Internal rotation)

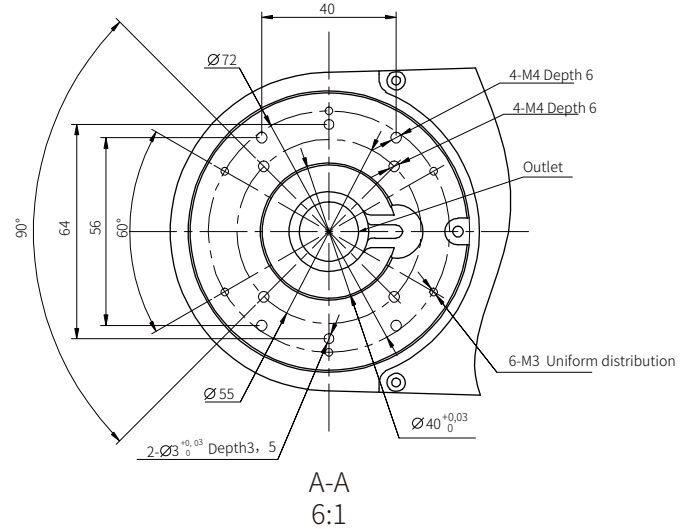

Note: Some hardware of the control panel of the robot arm is not shown in the illustration, please refer to the real product.

Specifications

Item Z-Arm XX50	Parameters
1-axis arm length	275mm
1-axis rotation angle	±90°
2-axis arm length	225mm
2-axis rotation angle	±164° (Optional: 15°~345°)
Z-axis stroke	410 (Customizable height)
R-axis rotation range	±1080° No mechanical limit / ±170° With mechanical limit
Linear speed	1400mm/s (Payload 4kg)
Repeatability	±0.05mm
Standard payload	4kg
Maximum payload	5kg
Degree of freedom	4
Power supply	220V/110V50-60HZ adapted to DC48V peak power 960W
Communication	Ethernet
Z-Axis can be customized in height	0.1~1m
Electrical reserved interface	Standard: Socket panel straight through small arm lower cover plate, 2 pieces of 4*23awg (unshielded) wire Optional: Socket panel straight through flange, 2 pieces of φ4 air pipe
Optional accessories	Z-EFG-8S/Z-EFG-12/Z-EFG-20/Z-EFG-20S/Z-EFG-20F/Z-ERG-20C/ Z-EFG-30/Z-EFG-50/Z-EFG-100, 5th axis, 3D printing
Working environment	Temperature: 0~45°C Humidity: 20~80%RH (non-condensing)
I/O port digital quantity input (Isolated)	9+3+arm extension (8 in and 8 out; gripper dedicated port: pulse or 485)
I/O port digital quantity output (Isolated)	9+3+arm extension (8 in and 8 out; gripper dedicated port: pulse or 485)
I/O port analog quantity input (4-20mA)	/
I/O port analog quantity output (4-20mA)	/
Machine height	830mm
Machine weight	410mm stroke net weight is about 28kg
Base external dimensions	250*250*15mm
Distance between base fixing holes	200*200mm equipped with four M8*20 screws
Collision detection	/
Drag teaching	✓
Hard emergency stop	✓
Debugging/Online upgrading (USB port)	✓
Outlet specification	AC cable & DC cable:2 meters
Cycle time	2.370s

Z-Arm 4160/Z-Arm XX60



- High precision**
Repeatability $\pm 0.05\text{mm}$
- Customizable Z-Axis**
0.1-1m
- Arm span**
J1 Axis 325mm
J2 Axis 275mm
- Cost-effective**
Industrial-grade quality
Competitive price

Integrated design of end effector



Range of motion and dimension

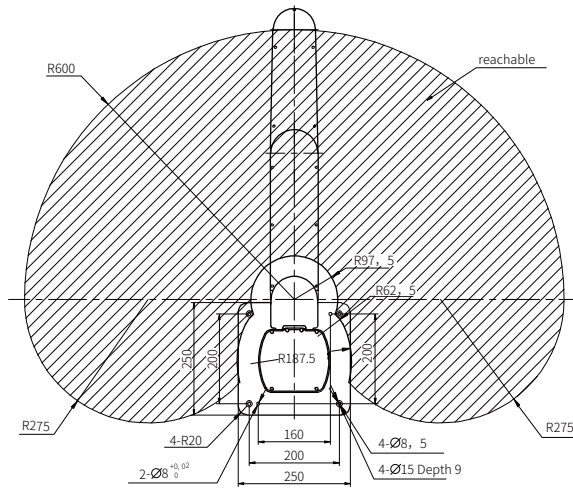

M1Version
(External rotation)

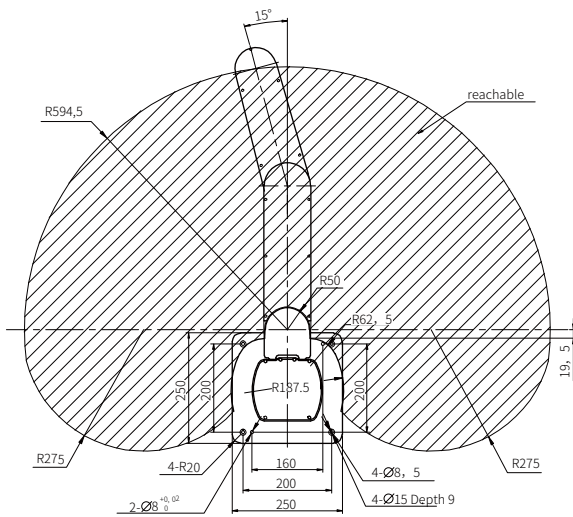
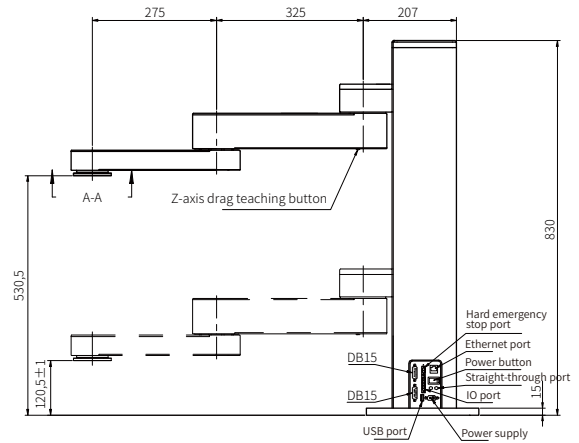

M2Version
(Internal rotation)

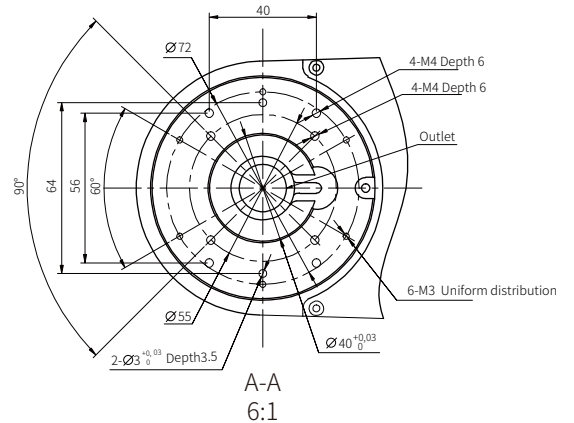

Note: Some hardware of the control panel of the robot arm is not shown in the illustration, please refer to the real product.

Specifications

Item Z-Arm XX60	Parameters
1-axis arm length	325mm
1-axis rotation angle	$\pm 90^\circ$
2-axis arm length	275mm
2-axis rotation angle	$\pm 164^\circ$ (Optional: $15^\circ \sim 345^\circ$)
Z-axis stroke	410 (Height customizable)
R-axis rotation range	$\pm 1080^\circ$ No mechanical limit / $\pm 170^\circ$ With mechanical limit
Linear speed	1500mm/s (Payload 3kg)
Repeatability	$\pm 0.05\text{mm}$
Standard payload	3kg
Maximum payload	3.5kg
Degree of freedom	4
Power supply	220V/110V50-60HZ adapted to DC48V peak power 960W
Communication	Ethernet
Z-Axis can be customized in height	0.1~1m
Electrical reserved interface	Standard: Socket panel straight through small arm lower cover plate, 2 pieces of 4*23awg (unshielded) wire Optional: Socket panel straight through flange, 2 pieces of $\phi 4$ air pipe
Optional accessories	Z-EFG-8S/Z-EFG-12/Z-EFG-20/Z-EFG-20S/Z-EFG-20F/Z-ERG-20C/Z-EFG-30/Z-EFG-50/Z-EFG-100, 5th axis, 3D printing
Working environment	Temperature: $0 \sim 45^\circ\text{C}$ Humidity: 20~80%RH (non-condensing)
I/O port digital quantity input (Isolated)	9+3+arm extension (8 in and 8 out; gripper dedicated port: pulse or 485)
I/O port digital quantity output (Isolated)	9+3+arm extension (8 in and 8 out; gripper dedicated port: pulse or 485)
I/O port analog quantity input (4-20mA)	/
I/O port analog quantity output (4-20mA)	/
Machine height	830mm
Machine weight	410mm stroke net weight is about 28.5kg
Base external dimensions	250*250*15mm
Distance between base fixing holes	200*200mm equipped with four M8*20 screws
Collision detection	/
Drag teaching	✓
Hard emergency stop	✓
Debugging/Online upgrading (USB port)	✓
Outlet specification	AC cable & DC cable: 2 meters
Cycle time	2.112s

Z-Arm 4160B/Z-Arm XX60B



High precision

Repeatability $\pm 0.02\text{mm}$

Customizable Z-Axis

0.1-0.8m

Large payload

Standard payload 4 kg
Maximum payload 5 kg

Maximum speed

Standard payload 5 kg
line speed 2m/s

Cost-effective

Industrial-grade quality
Competitive price

Integrated design of end effector



Range of motion and dimension

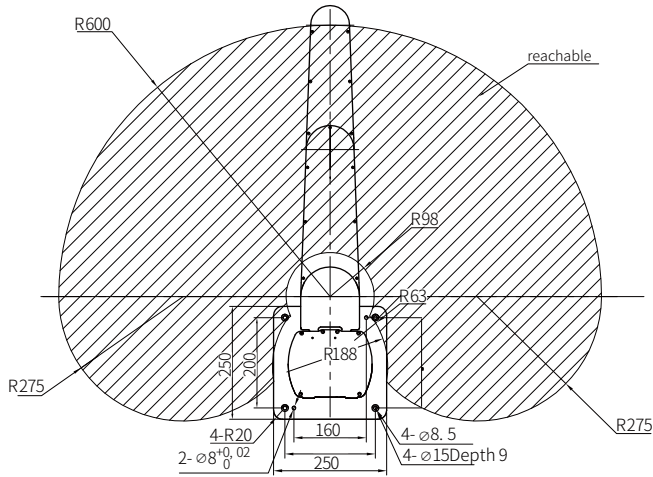

M1Version
(External rotation)

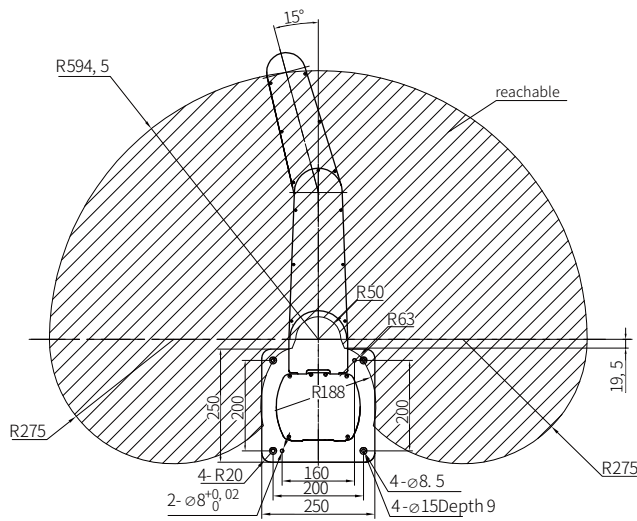
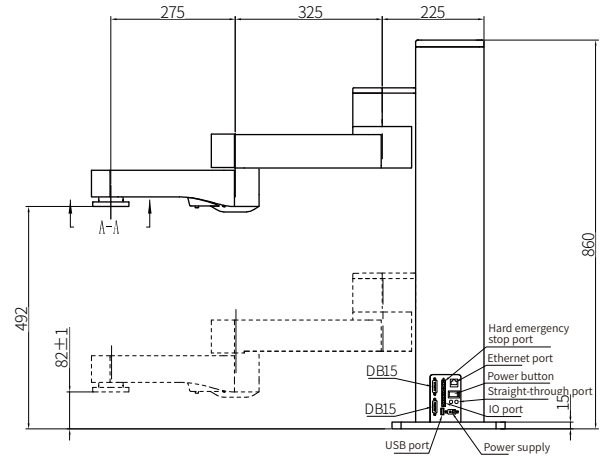

M2Version
(Internal rotation)

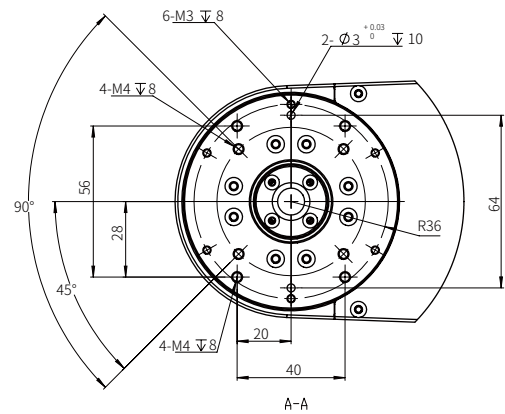

Note: Some hardware of the control panel of the robot arm is not shown in the illustration, please refer to the real product.

Specifications

Item Z-Arm XX60B	Parameters
1-axis arm length	325mm
1-axis rotation angle	±90°
2-axis arm length	275mm
2-axis rotation angle	±164° (Optional: 15°~345°)
Z-axis stroke	410 (Customizable height)
R-axis rotation range	±1080° No mechanical limit / ±170° With mechanical limit
Linear speed	2000mm/s (Payload 4kg)
Repeatability	±0.02mm
Standard payload	4kg
Maximum payload	5kg
Degree of freedom	4
Power supply	220V/110V50-60HZ adapted to DC48V peak power 2000W
Communication	Ethernet
Z-Axis can be customized in height	0.1~0.8m
Electrical reserved interface	Standard: Socket panel straight through small arm lower cover plate, 2 pieces of 4*23awg (unshielded) wire Optional: Socket panel straight through flange, 2 pieces of φ4 air pipe
Optional accessories	Z-EFG-8S/Z-EFG-12/Z-EFG-20/Z-EFG-20S/Z-EFG-20F/Z-ERG-20C/ Z-EFG-30/Z-EFG-50/Z-EFG-100
Working environment	Temperature: 0~45°C Humidity: 20~80%RH (non-condensing)
I/O port digital quantity input (Isolated)	9+3+arm extension (8 in and 8 out; gripper dedicated port: pulse or 485)
I/O port digital quantity output (Isolated)	9+3+arm extension (8 in and 8 out; gripper dedicated port: pulse or 485)
I/O port analog quantity input (4-20mA)	/
I/O port analog quantity output (4-20mA)	/
Machine height	860mm
Machine weight	410mm stroke net weight is about 36.5kg
Base external dimensions	250*250*15mm
Distance between base fixing holes	200*200mm equipped with four M8*20 screws
Collision detection	/
Drag teaching	/
Hard emergency stop	✓
Debugging/Online upgrading (USB port)	✓
Outlet specification	AC cable & DC cable:2 meters
Cycle time	1.431s

Z-Arm S622 Cobot



Control box



Button box

Horizontal and vertical,
comprehensive in all aspects

Easy to operate
Highly integrated
Wide range of applications

Space saving
Easy to deploy

Lightweight and flexible
Cost-effective

Specifications

Item	Parameters
Weight	≈15kg
Effective Payload	3kg
Working Range	622mm
Joint Range of Motion Software Limits	1 axis: ±175° 2 axis: +85°, -265° 3 axis: ±150° 4 axis: +85°, -265° 5 axis: ±175° 6 axis: ±175°
Typical TCP Speed	1m/s
Repeatability	±0.02mm
Installation Area	φ128mm
Mounting Direction	Vertical, Horizontal, Inverted
Control Box Size	245*180*44.5mm
Degree of Freedom	6
End I/O Ports	Digital Input (DI) : 2 Digital Output (DO) : 2 analog input (AI) : 1 analog output (AO) : 1
Control Box I/O Ports	Digital Input (DI) : 16 Digital Output (DO) : 16 analog input (AI) : 2 analog output (AO) : 2
I/O Power Supply	24V/1.5A
Communication	I/O、TCP/IP、Modbus_TCP/RTU、Profinet
Development Environment	C#/C++/Python/java/ROS
Noise	<65dB
Protection Level	IP54
Coordinated Operation	Equipped with collision detection, allowing for custom collision levels
Power Supply	220V/50HZ
Working Environment	<ul style="list-style-type: none"> · Keep away from corrosive gases, liquids and explosive gases · Keep away from vibrations, and vibration intensity should not exceed 0.5G · Avoid operating the equipment under unstable current conditions · Avoid dust, smoke, and water
Temperature Range	0~45°C
Humidity Range	20-80%RH (Non-condensing)
Outlet Specification	Cable length 3.7m

Range of motion and dimension

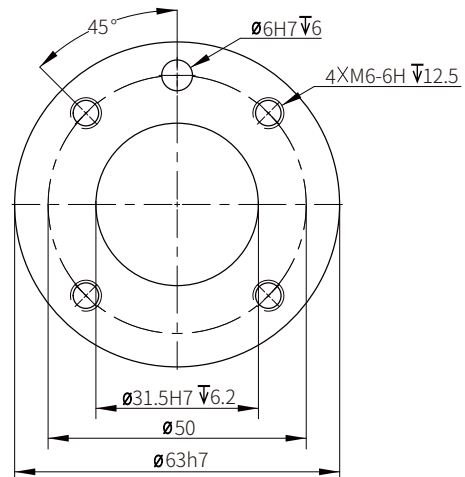
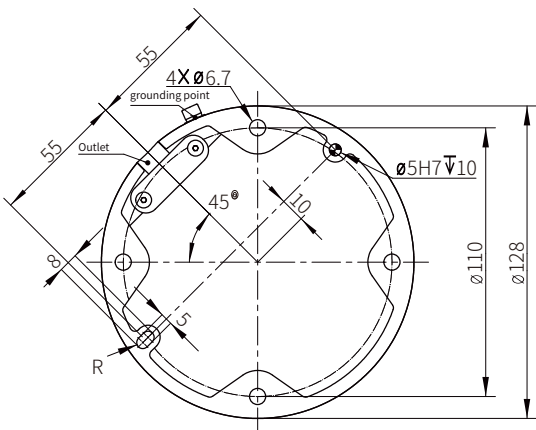
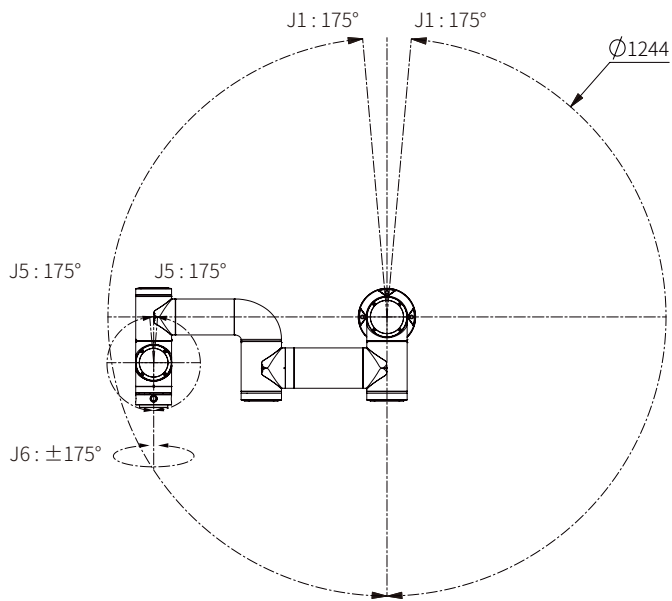
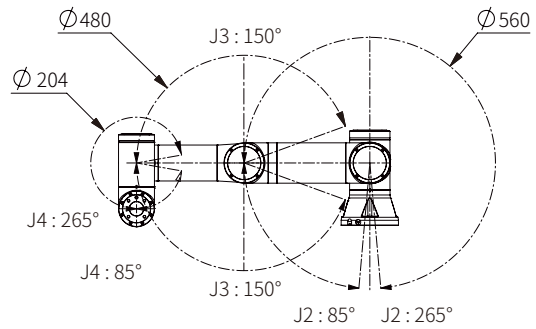
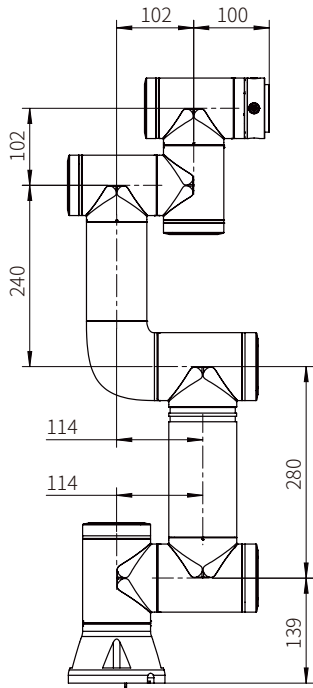

International standard adopted for the robot end effector

Z-Arm S922 Cobot



Control box



Button box

Horizontal and vertical,
comprehensive in all
aspects

Easy to operate

Drag teaching and graphical programming effectively reduce application threshold and time cost, with a user-friendly PC operating interface.

Highly Integrated

Reducer, motor, encoder, and drive control are integrated in one unit for quick disassembly and assembly.

Wide Range of Application

Can be used in the automotive industry, electronics industry, food and beverage industry, medical and health care, and laboratory research fields, etc.; meet various functional requirements, such as assembly, picking and placing, screw twisting, and glue dispensing.

Specifications

Item	Parameters
Weight	≈22kg
Effective Payload	5kg
Working Range	922mm
Joint Range of Motion Software Limits	1axis: ±175° 2axis: +85°, -265° 3axis: ±160° 4axis: +85°, -265° 5axis: ±175° 6axis: ±175°
Typical TCP Speed	1m/s
Repeatability	±0.02mm
Installation Area	φ149mm
Mounting Direction	Vertical, Horizontal, Inverted
Control Box Size	245*180*44.5mm
Degree of Freedom	6
End I/O Ports	Digital Input (DI) : 2 Digital Output (DO) : 2 analog input (AI) : 1 analog output (AO) : 1
Control Box I/O Ports	Digital Input (DI) : 16 Digital Output (DO) : 16 analog input (AI) : 2 analog output (AO) : 2
I/O Power Supply	24V/1.5A
Communication	I/O、TCP/IP、Modbus_TCP/RTU、Profinet
Development Environment	C#/C++/Python/java/ROS
Noise	<65dB
Protection Level	IP54
Coordinated Operation	Equipped with collision detection, allowing for custom collision levels
Power Supply	220V/50HZ
Working Environment	<ul style="list-style-type: none"> · Keep away from corrosive gases, liquids and explosive gases · Keep away from vibrations, and vibration intensity should not exceed 0.5G · Avoid operating the equipment under unstable current conditions · Avoid dust, smoke, and water
Temperature Range	0~45°C
Humidity Range	20~80%RH (Non-condensing)
Outlet Specification	Cable length 3.7m

Range of motion and dimension

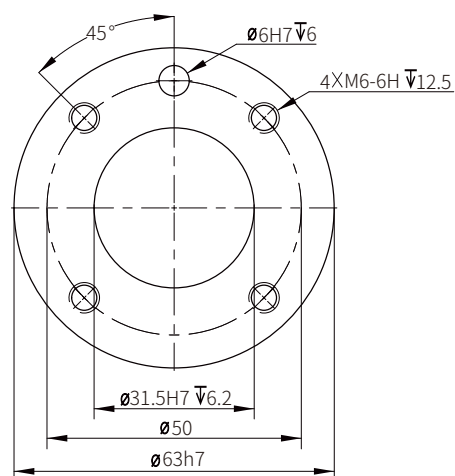
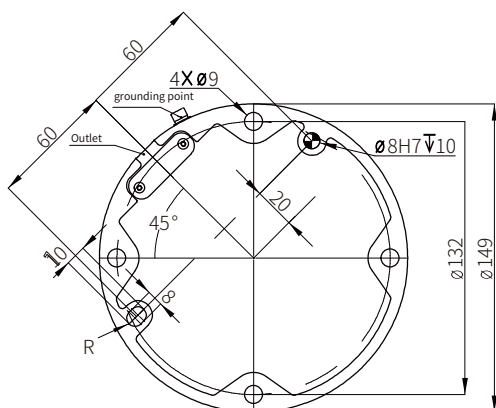
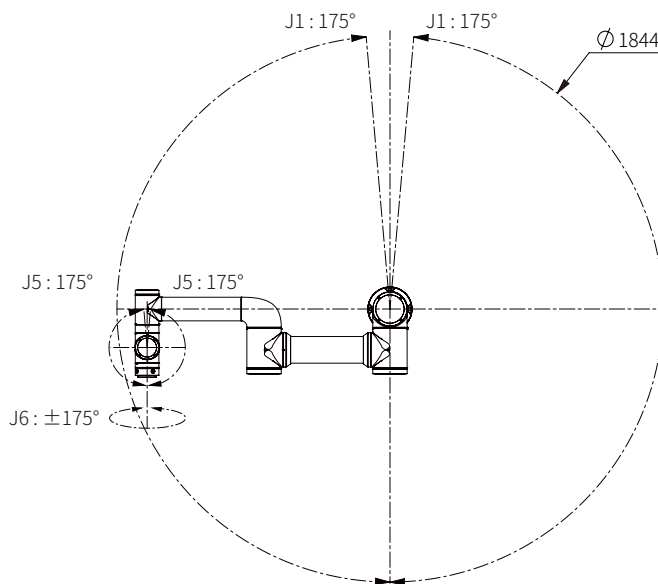
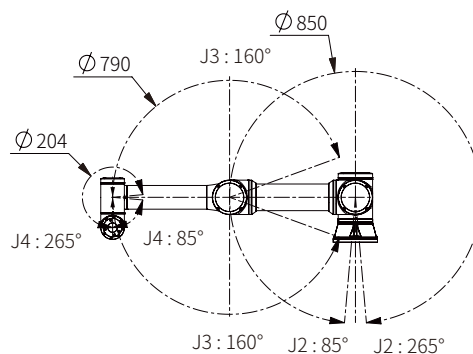
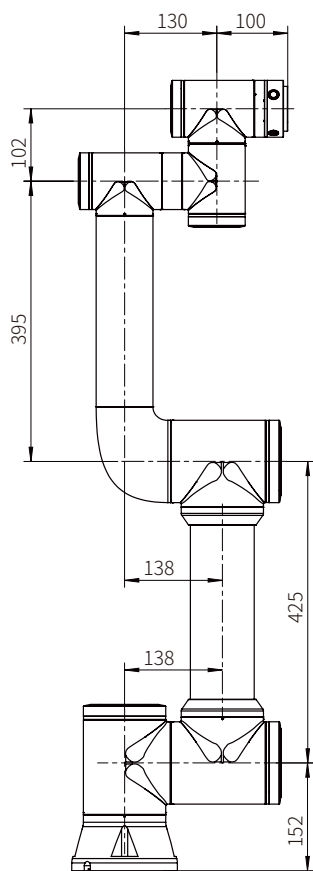

International standard adopted for the robot end effector

Z-Arm S1400 Cobot



Control box



Button box

Horizontal and vertical,
comprehensive in all aspects

Easy to operate
Highly Ingerated
Wide Range of Application

Larger payload
Longer arm reach
Higher Precision

Specifications

Item	Parameters
Weight	≈40kg
Effective Payload	10kg
Working Range	1400mm
Joint Range of Motion Software Limits	1axis: ±175° 2axis: +85°, -265° 3axis: ±160° 4axis: +85°, -265° 5axis: ±175° 6axis: ±175°
Typical TCP Speed	1m/s
Repeatability	±0.05mm
Installation Area	φ190mm
Mounting Direction	Vertical, Horizontal, Inverted
Control Box Size	245*180*44.5mm
Degree of Freedom	6
End I/O Ports	Digital Input (DI) : 2 Digital Output (DO) : 2 analog input (AI) : 1 analog output (AO) : 1
Control Box I/O Ports	Digital Input (DI) : 16 Digital Output (DO) : 16 analog input (AI) : 2 analog output (AO) : 2
I/O Power Supply	24V/1.5A
Communication	I/O、TCP/IP、Modbus_TCP/RTU、Profinet
Development Environment	C#/C++/Python/java/ROS
Noise	<65dB
Protection Level	IP54
Coordinated Operation	Equipped with collision detection, allowing for custom collision levels
Power Supply	220V/50HZ
Working environment	· Keep away from corrosive gases, liquids and explosive gases · Keep away from vibrations, and vibration intensity should not exceed 0.5G · Avoid operating the equipment under unstable current conditions · Avoid dust, smoke, and water
Temperature Range	0~45°C
Humidity Range	20~80%RH (Non-condensing)
Outlet Specification	Cable length 3.7m

Range of motion and dimension

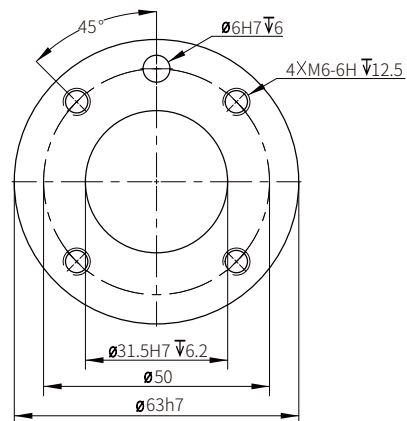
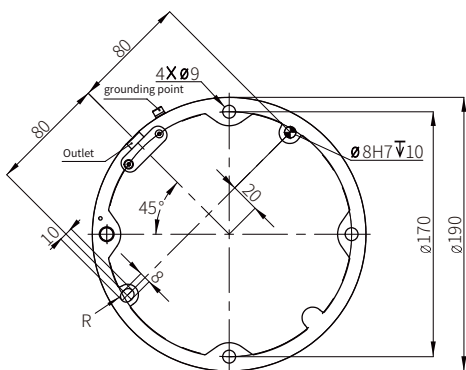
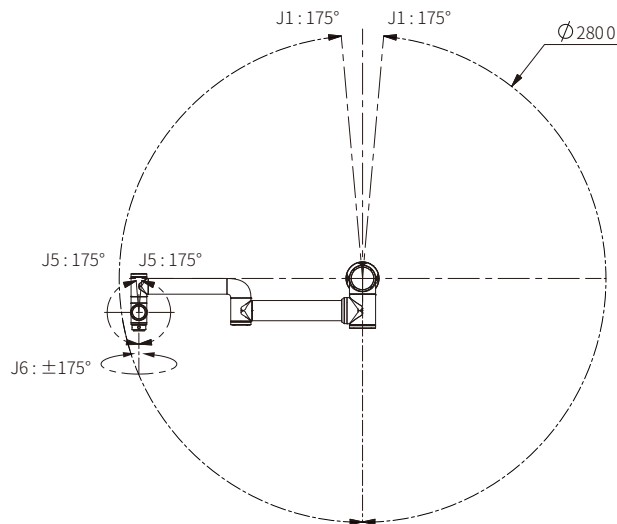
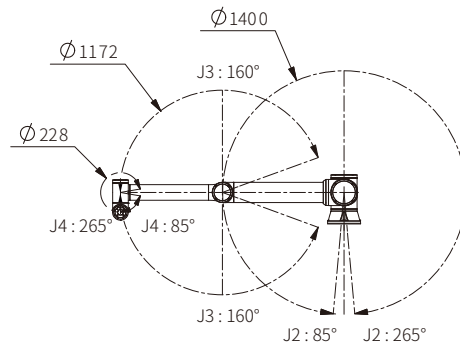
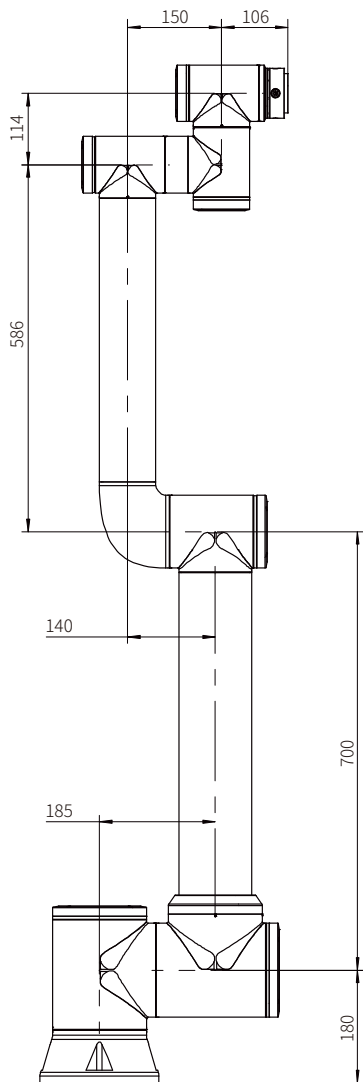

International standard adopted for the robot end effector

Z-Arm S1034 Cobot



Control box



Button box

Horizontal and vertical,
comprehensive in all aspects

Easy to operate
Highly Ingerated
Wide Range of Application

Larger payload
Longer arm reach
Higher Precision

Specifications

Item	Parameters
Weight	≈40kg
Effective Payload	16kg
Working Range	1034mm
Joint Range of Motion Software Limits	1axis: ±175° 2axis: +85°, -265° 3axis: ±160° 4axis: +85°, -265° 5axis: ±175° 6axis: ±175°
Typical TCP Speed	1m/s
Repeatability	±0.05mm
Installation Area	φ190mm
Mounting Direction	Vertical, Horizontal, Inverted
Control Box Size	245*180*44.5mm
Degree of Freedom	6
End I/O Ports	Digital Input (DI) : 2 Digital Output (DO) : 2 analog input (AI) : 1 analog output (AO) : 1
Control Box I/O Ports	Digital Input (DI) : 16 Digital Output (DO) : 16 analog input (AI) : 2 analog output (AO) : 2
I/O Power Supply	24V/1.5A
Communication	I/O、TCP/IP、Modbus_TCP/RTU、Profinet
Development Environment	C#/C++/Python/java/ROS
Noise	<65dB
Protection Level	IP54
Coordinated Operation	Equipped with collision detection, allowing for custom collision levels
Power Supply	220V/50HZ
Working environment	· Keep away from corrosive gases, liquids and explosive gases · Keep away from vibrations, and vibration intensity should not exceed 0.5G · Avoid operating the equipment under unstable current conditions · Avoid dust, smoke, and water
Temperature Range	0~45°C
Humidity Range	20-80%RH (Non-condensing)
Outlet Specification	Cable length 3.7m

Range of motion and dimension

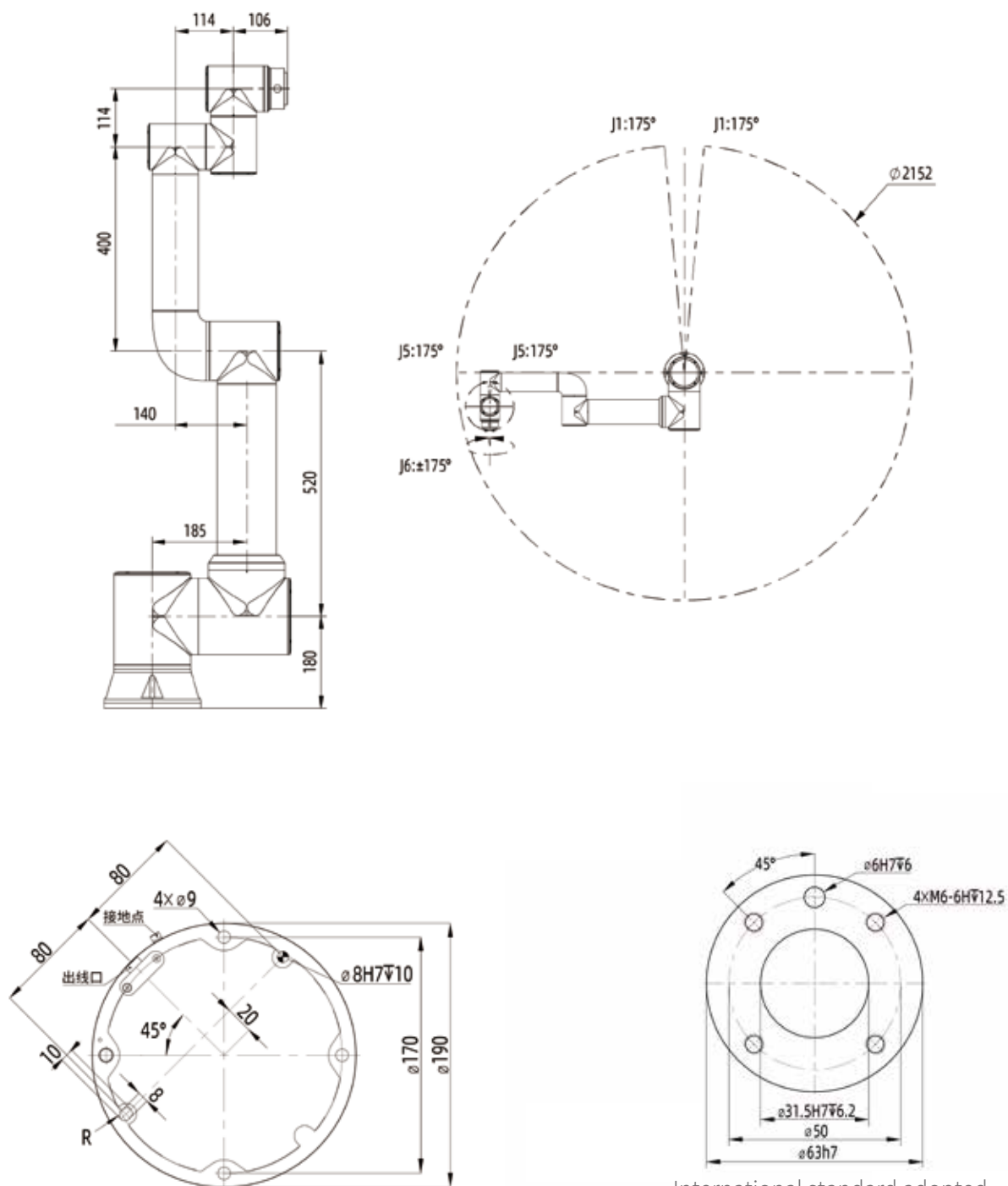

International standard adopted for the robot end effector

Z-Arm S1854 Cobot



Specifications



Control box



Button box

Horizontal and vertical,
comprehensive in all aspects

Easy to operate
Highly Ingerated
Wide Range of Application

Larger payload
Longer arm reach
Higher Precision

Item	Parameters
Weight	≈85kg
Effective Payload	20kg
Working Range	1854mm
Joint Range of Motion Software Limits	1axis: ±175° 2axis: +85°, -265° 3axis: ±160° 4axis: +85°, -265° 5axis: ±175° 6axis: ±175°
Typical TCP Speed	2m/s
Repeatability	±0.1mm
Installation Area	φ240mm
Mounting Direction	Vertical, Horizontal, Inverted
Control Box Size	245*180*44.5mm
Degree of Freedom	6
End I/O Ports	Digital Input (DI) : 2 Digital Output (DO) : 2 analog input (AI) : 1 analog output (AO) : 1
Control Box I/O Ports	Digital Input (DI) : 16 Digital Output (DO) : 16 analog input (AI) : 2 analog output (AO) : 2
I/O Power Supply	24V/1.5A
Communication	I/O、TCP/IP、Modbus_TCP/RTU、Profinet
Development Environment	C#/C++/Python/java/ROS
Noise	<70dB
Protection Level	IP54
Coordinated Operation	Equipped with collision detection, allowing for custom collision levels
Power Supply	220V/50HZ
Working environment	· Keep away from corrosive gases, liquids and explosive gases · Keep away from vibrations, and vibration intensity should not exceed 0.5G · Avoid operating the equipment under unstable current conditions · Avoid dust, smoke, and water
Temperature Range	0~45°C
Humidity Range	20-80%RH (Non-condensing)
Outlet Specification	Cable length 3.7m

Range of motion and dimension

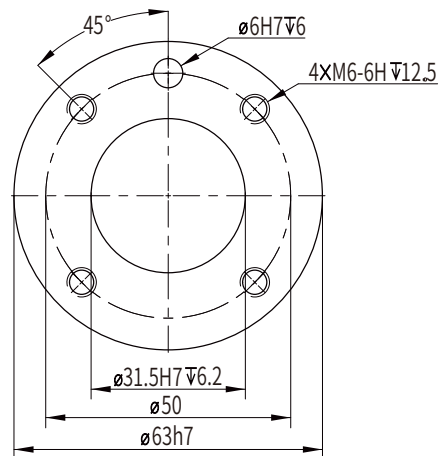
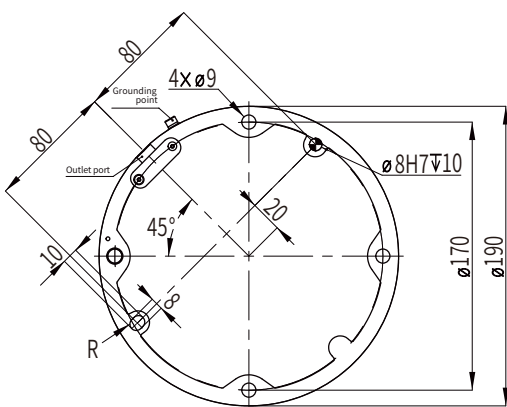
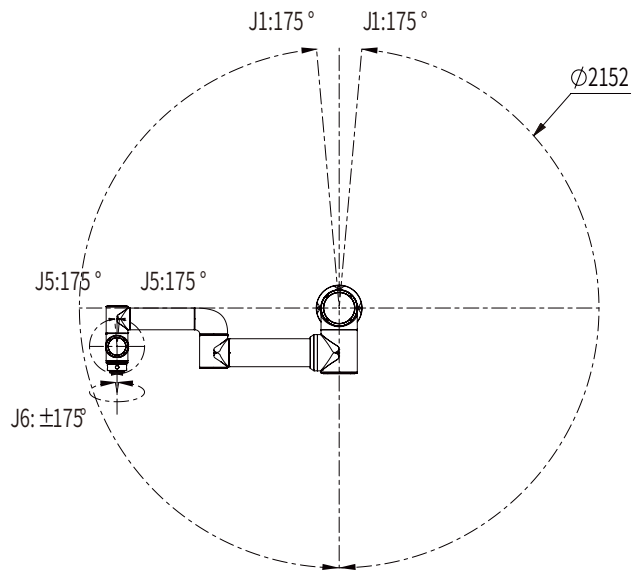
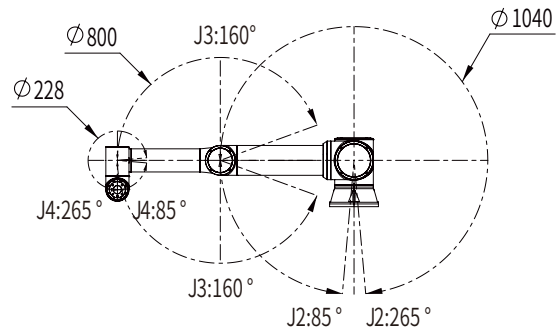
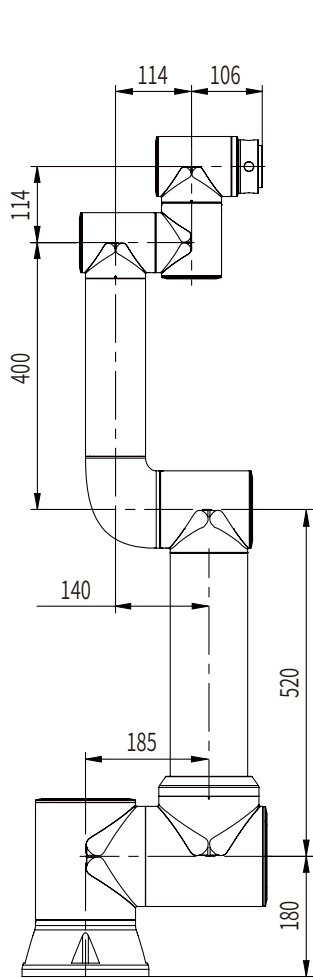

International standard adopted for the robot end effector

Software Description

Four-axis Software Description

This software is based on graphical programming and provides basic function modules such as position, output signals, electric grippers, trays, delay, sub-processes, reset, etc. Users can drag and drop the above basic modules in the programming area to achieve logic control of the robotic arm-related process, which is convenient, intuitive, simple, and easy to learn.

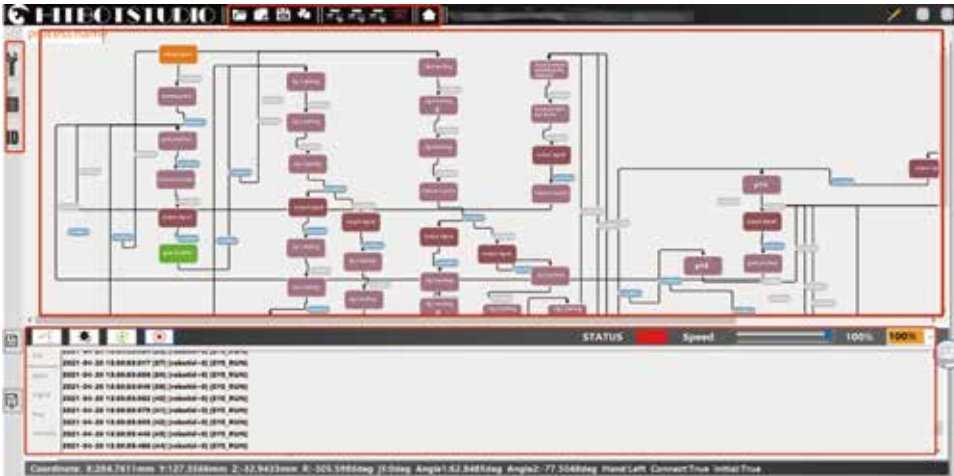

Six-Axis Software Description

The control of the six-axis robotic arm is based on the WEB. Users can easily access the control page through a browser to operate the robotic arm. The software provides multiple motion modes and rich tool control. The arm supports drag teaching, trajectory teaching, and collision protection, making human-robot collaboration simpler and more convenient. It also supports tool coordinate setting, modularization of programming elements, graphical and command configuration, low-code, simplicity, easy learning, and easy maintenance.

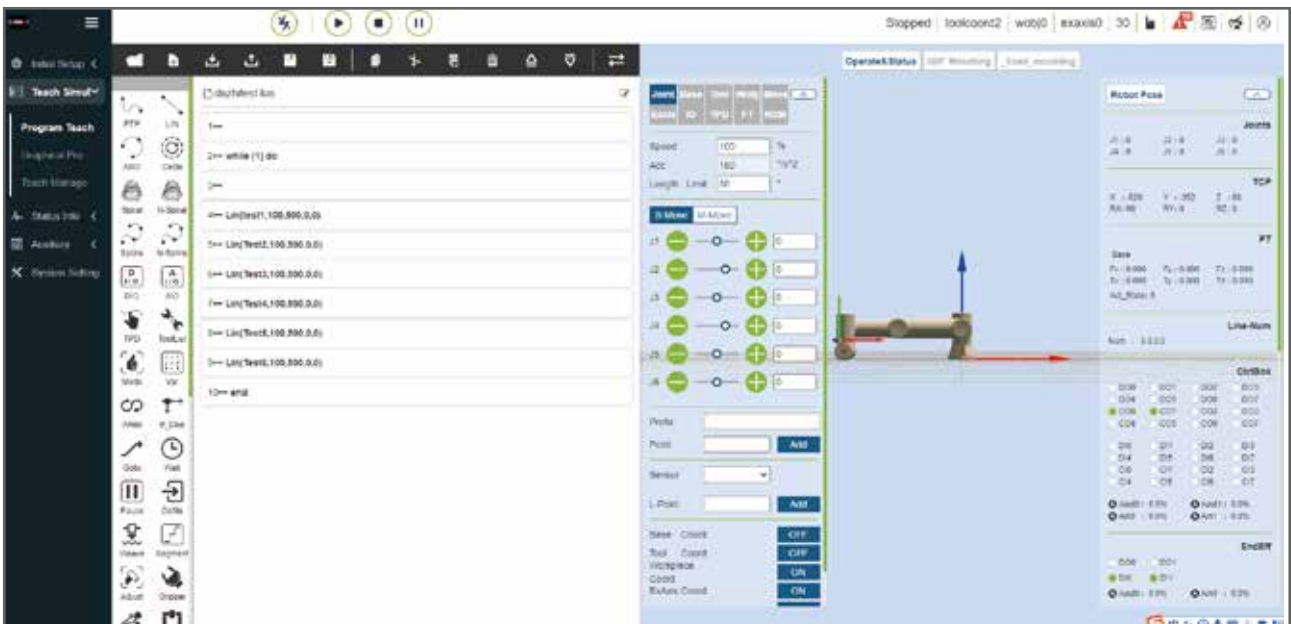

Grippers for 6-Axis Robotic Arm

 Adapted

 Non-supported

Gripper Model	IO	485
Z-EFG-8S	✓	✗
Z-EFG-12	✓	✗
Z-EFG-20	✓	✗
Z-EFG-20P	✓	✓
Z-EFG-50	✓	✓
Z-ESC-70-1	✓	✓
Z-ESC-70-4	✓	✓
Z-ERG-20C	✓	✓
Z-ERG-20-100	✓	✓
Z-EFG-C35	✓	✓
Z-EFG-C50	✓	✓
Z-EFG-C65	✓	✓
Z-ECG-20	✓	✓
Z-EFG-100	✓	✓
Z-EFG-130	✓	✓
Z-EFG-40-100	✗	✗
Z-EFG-60-150	✗	✗
Z-EFG-80-200	✗	✗

Gripper for Four-axis Robotic arm

Adapted

Non-supported

Robot Model Gripper Model		Hard Emergency Stop Version				
		XX32	XX42	XX42E	XX50	XX60
Z-EFG-Pulse type	Z-EFG-20-NM	✓	✓	✓	✓	✓
	Z-EFG-8S-NK	✓	✓	✓	✓	✓
Z-EFG-I/O type	Z-EFG-12-NK	✓	✓	✓	✓	✓
	Z-EFG-20-NK	✓	✓	✓	✓	✓
	Z-EFG-20S-NK	✓	✓	✓	✓	✓
	Z-EFG-20F-ALL	✗	✓	✓	✓	✓
	Z-EFG-20P-ALL	✗	✓	✓	✓	✓
Z-EFG-485 type	Z-EFG-26-ALL	✗	✓	✓	✓	✓
	Z-EFG-26P-ALL	✗	✓	✓	✓	✓
	Z-EFG-30-ALL	✗	✓	✓	✓	✓
	Z-EFG-50-ALL	✗	✓	✓	✓	✓
	Z-EFG-100-TXA	✗	✗	✗	✗	✗
	Z-ERG-20-ALL	✗	✗	✗	✗	✗
	Z-ERG-20C-ALL	✗	✓	✓	✓	✓
	Z-ERG-20-100-ALL	✗	✓	✓	✓	✓
	Z-ECG-10-ALL	✗	✗	✗	✗	✗
	Z-ESC-70-ALL	✗	✓	✓	✓	✓
	Z-EFG-C35-ALL	✗	✓	✓	✓	✓
	Z-EFG-C50-ALL	✗	✗	✗	✗	✗
	Z-EFG-C65-ALL	✗	✗	✗	✗	✗
	Z-ECG-20-ALL	✗	✗	✗	✗	✗
	Z-EFG-130-ALL	✗	✓	✓	✓	✓
	Z-EFG-40-100-ALL	✗	✗	✗	✗	✗
	Z-EFG-60-150-ALL	✗	✗	✗	✗	✗
	Z-EFG-80-200-ALL	✗	✗	✗	✗	✗



Hitbot electric gripper

The internal integrated servo system can meet the needs of flexible clamping in production, digital control, and precise control of speed, position and clamping strength.



Electric Gripper Series

Driving a revolution of electric replacing pneumatic, leading domestically in small electric grippers with integrated servo systems

- Z-EFG-8S/Z-EFG-FS: Adjustable gripping force
- Z-EFG-20/Z-EFG-R: Adjustable stroke
- Z-EFG-12/Z-EFG-L: Design of electric gripper vs. frequency of pneumatic gripper
- Z-EFG-30/Z-EFG-50: Precise control through Modbus
- Z-ERG-20 Rotary gripper : supports infinite rotation

The Z-EFG series is a small electric gripper with integrated servo systems that leads domestically. It can perfectly replace an air compressor + filter + solenoid valve + throttle valve + pneumatic gripper.

The Z-EFG series supports flexible gripping and can grip fragile and deformable items such as test tubes and eggs, which pneumatic grippers cannot do.

The end-effectors of the electric gripper Z-EFG series can be replaced at any time, and users can design their own end-effectors according to the objects they need to grip to ensure that the gripper can maximize its gripping capabilities.

The Z-EFG series can be adapted to robots such as Universal Robots, Aubo, and Ailite, and can be called directly in the Urcap library of UR robots.

- Can grip fragile and deformable objects such as test tubes, eggs, and rings
- For use in places without air supply such as laboratories and hospitals
- Long lifespan: surpasses the pneumatic gripper with millions of cycles
- Built-in controller: small footprint, easy to integrate
- Multiple control methods



Z-EFG-8S



Z-EFG-12



Z-EFG-20



Z-EFG-20P



Z-EFG-20F



Z-EFG-50PALL



Z-EFG-50PECT



Z-EFG-80



Z-EFG-40-100



Z-EFG-60-150



Z-EFG-C35



Z-EFG-C50



Z-EFG-C65



Z-EFG-C80

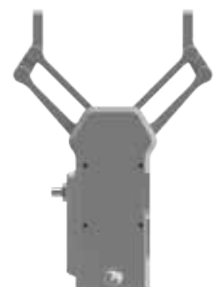

Z-EFG-100

Model definition

Z-EFG-8SPK-U-FXXX-01

EFG	8S	PK	U	FXXX-01
EFG: 2-finger parallel electric gripper ECG: 3-finger slider electric gripper EMG: electromagnetic electric gripper ERG: rotary electric gripper	4: 4mm Stroke 8S: 8mm Stroke 10: 10mm Stroke 12: 12mm Stroke 20/20S/20P/20F/20C: 20mm Stroke 26/26P: 26mm Stroke 30: 30mm Stroke C35: 35mm Stroke 40: 40mm Stroke 50/C50: 50mm Stroke 60: 60mm Stroke C65: 65mm Stroke 80: 80mm Stroke 100: 90mm Stroke 130: 120mm Stroke FS: 8mm stroke hex-axis robotic arm upgrade version R: 20mm stroke hex-axis robotic arm upgrade version L: 12mm stroke hex-axis robotic arm upgrade version	Communication mode: NK: Standard NPN type I/O control NM: Standard NPN type pulse control PK: Standard NPN type I/O control PM: Standard PNP Pulse Control NMA: NPN-type Pulse Control Power-On Hold PMA: PNP-type Pulse Control Power-On Hold TXA: RS-485 Communication ALL: RS-485 Communication+IO (Note 2)	Cable outlet method (Note 1): HCA: 5-core aviation plug male connector (GX12) HCB: 4-core aviation plug male connector (M8) HW: Rubber tail wire U: UR version outlet (plug + Lumberg cable) A: AUBO version outlet (plug + Lumberg cable) E: ELITE version outlet S: Compatible with S622/S922/S1400 Z1: Outlet used with HITBOT XX32 (unshielded wire) Z2: Outlet used with HITBOT 2140/XX42 (non-hollow flange) (unshielded wire) Z3: Outlet used with HITBOT XX42/XX60/XX50 (hollow flange internal wiring) LMC: Nut side outlet LMH: Nut rear outlet CG: Side cover	F: Customization option, if it is a standard product, it is blank. XXX: Customer number 01: Version number

Note 1: Unless specifically stated (such as with HITBOT), shielded wire is provided.

Note 2: I/O can run points set by 485 (standard NPN type).

Note 3: The above communication and cable outlet methods are based on the actual machine parameters, not arbitrary options.



Z-EFG-20S



Z-EFG-26



Z-EFG-26P



Z-EFG-30



Z-EFG-50



Z-EFG-80-200



Z-EFG-FS



Z-EFG-L



Z-EFG-R



Z-EFG-RP



Z-EFG-130



Z-ECG-10



Z-ECG-20



Z-ERG-20C



Z-ERG-20-100

Electric Gripper Series

Specifications



Item	Parallel electric gripper					
	Z-EFG-8S	Z-EFG-12	Z-EFG-20	Z-EFG-20P	Z-EFG-20F	Z-EFG-20S
Total stroke	8mm	12mm	20mm	20mm	20mm	20mm
Clamping force	8~20N	30N	30~80N	30~80N	1~8N	8~20N
Recommended clamping weight ≤	0.3kg	0.5kg	0.8kg	0.8kg	0.1kg	0.3kg
Stroke adjustment	Non-adjustable	Non-adjustable	Adjustable	Adjustable	Adjustable	Non-adjustable
Clamping force adjustment	Adjustable	Non-adjustable	Adjustable	Adjustable	Adjustable	Adjustable
Machine weight	0.25kg	0.34kg	0.46kg	0.46kg	0.5kg	0.35kg
Dimensions	30*24*93.9mm	48*32*105.6mm	44*30*124.7mm	44*30*124.7mm	52*32*103mm	43*24*93.9mm
One-way motion time	0.1s	0.2s	0.45s	0.4s	0.1s	0.15s
Rated voltage	24V	24V	24V	24V	24V	24V
Peak current	0.6A	1A	1A	1A	1A	0.6A
Optional communication	NK/PK	NK/PK	NK/PK/NM/PM	ALL	ALL	NK/PK
Optional outlet	HW/Z1/CG	HW	HCA/HW/Z1/CG	CG	LMC	HW
Standard outlet specification	Cable length 45cm, 5 cores	Cable length 45cm, 5 cores	Cable length 45cm, 5 cores	Cable length 2m, 8 cores	Cable length 2m, 8 cores	Cable length 45cm, 5 cores

Note:The recommended clamping weight and maximum clamping weight are not the same concept, and the maximum clamping weight is directly related to the fixture design. The maximum clamping weight is about 3-4 times the recommended clamping weight. (Due to continuous product updates and iterations, if there are changes in product parameters, we will not notify separately.)



Parallel electric gripper

Z-EFG-26	Z-EFG-26P	Z-EFG-30	Z-EFG-50	Z-EFG-50PALL	Z-EFG-50PECT
26mm	26mm	30mm	50mm	50mm	50mm
6~15N	15~50N	10~40N	15~50N	15~50N	15~50N
0.3kg	0.5kg	0.4kg	0.5kg	0.5kg	0.5kg
Adjustable	Adjustable	Adjustable	Adjustable	Adjustable	Adjustable
Adjustable	Adjustable	Adjustable	Adjustable	Adjustable	Adjustable
0.45kg	0.5kg	0.55kg	0.7kg	1kg	1kg
55*26*97mm	55*29*103mm	52*38*108mm	68*38*108mm	84*38*108mm	84*38*108mm
0.25s	0.3s	0.2s	0.3s	0.3s	0.3s
24V	24V	24V	24V	24V	24V
1A	1A	2A	2A	2A	2A
ALL	ALL	ALL	ALL	ALL	EtherCAT (External drive, does not occupy PLC axis position)
LMC	LMC	LMC/LMH/CG	LMC/LMH	LMC/LMH	LMC/LMH
Cable length 2m, 8 cores	Cable length 2m, 8 cores	Cable length 2m, 12 cores	Cable length 2m, 12 cores	Cable length 2m, 12 cores	Main cable 2m, 8 cores encoder cable and 5 cores power supply cable



Item	Parallel electric gripper	Collaborative electric gripper			
	Z-EFG-80	Z-EFG-C35	Z-EFG-C50	Z-EFG-C65	Z-EFG-C80
Total stroke	80mm	35mm	50mm	65mm	80mm
Clamping force	15~50N	15~50N	40~140N	60~300N	40~140N
Recommended clamping weight ≤	0.5kg	1kg	2kg	6kg	3kg
Stroke adjustment	Adjustable	Adjustable	Adjustable	Adjustable	Adjustable
Clamping force adjustment	Adjustable	Adjustable	Adjustable	Adjustable	Adjustable
Machine weight	0.85kg	0.5kg	1.15kg	1.65kg	1.5kg
Dimensions	98*38*108mm	63*63*92mm	72*72*100.5mm	90*90*115mm	95*80*97mm
One-way motion time	0.5s	0.5s	0.5s	0.8s	0.6s
Rated voltage	24V	24V	24V	24V	24V
Peak current	2A	1A	2A	2A	2A
Optional communication	ALL	ALL	ALL	ALL	ALL
Optional outlet	LMC/LMH	LMC	LMC	LMC	LMC/LMH
Standard outlet specification	Cable length 2m, 12 cores	Cable length 2m, 12 cores	Cable length 2m, 12 cores	Cable length 2m, 12 cores	Cable length 2m, 12 cores

Note:The recommended clamping weight and maximum clamping weight are not the same concept, and the maximum clamping weight is directly related to the fixture design. The maximum clamping weight is about 3-4 times the recommended clamping weight. (Due to continuous product updates and iterations, if there are changes in product parameters, we will not notify separately.)



Collaborative grippers				Wide grippers		
Z-EFG-FS	Z-EFG-L	Z-EFG-R	Z-EFG-RP	Z-EFG-40-100	Z-EFG-60-150	Z-EFG-80-200
8mm	12mm	20mm	20mm	40mm	60mm	80mm
8~20N	30N	30~80N	30~80N	30~200N (Adjustable)	40~300N (Adjustable)	60~400N (Adjustable)
0.3kg	0.5kg	0.8kg	0.8kg	1kg	1.7kg	2kg
Non-adjustable	Non-adjustable	Adjustable	Adjustable	Adjustable	Adjustable	Adjustable
Adjustable	Non-adjustable	Adjustable	Adjustable	Adjustable	Adjustable	Adjustable
0.3kg	0.4kg	0.5kg	0.5kg	1kg	1.7kg	2kg
67*67*101.9mm	68*68*113.6mm	68*68*132.7mm	44*30*124.7mm	119*37*85mm	140*47*112mm	172*50*105mm
0.1s	0.2s	0.45s	0.4s	0.4s	0.6s	0.8s
24V	24V	24V	24V	24V	24V	24V
0.6A	1A	1A	1A	4A	8A	8A
NK	NK	NK/NM/NMA	ALL	ALL	ALL	ALL
U/A/E/S/J/ J2 (Male)	U/A/E/S/J/ J2 (Male)	HCA/U/A/E/S/Z1/ J/J2 (Male)	CG	LMC	LMC	LMC
Cable length 15cm, 5 cores	Cable length 15cm, 5 cores	Cable length 15cm, 5 cores	Cable length 15cm, 5 cores	Cable length 2m, 12 cores	Cable length 2m, 12 cores	Cable length 2m, 12 cores



Y-type grippers		3-Fingers grippers		Item	Rotary electric gripper	
Z-EFG-100	Z-EFG-130	Z-ECG-10	Z-ECG-20		Z-ERG-20C	Z-ERG-20-100
90mm	130mm	10mm	20mm	Total Sstroke	20mm	20mm
35~60N	40~130N	3~10N	30~80N	Clamping force	10~35N	30~100N
0.5kg	1kg	0.2kg	1kg	Recommended clamping weight ≤	0.4kg	1kg
Adjustable	Adjustable	Adjustable	Adjustable	Stroke adjustment	0.3Nm	1.5Nm
Adjustable	Adjustable	Adjustable	Adjustable	Clamping force adjustment	180RPM	180RPM
0.93kg	0.8kg	0.5kg	1.5kg	Body weight	Infinte rotation	Infinte rotation
203*144*45mm (Open) 222*64*45mm (Close)	177*187*72mm (Open) 224*66.5*72mm (Close)	73*73*95.5mm	114*114*124.5mm	Machine weight Dimensions	1kg 54*54*141mm	1.2kg 54*54*170mm
1s	0.9s	0.3s	0.5s	One-way motion time	0.3s	0.3s
24V	24V	24V	24V	Rated voltage	24V	24V
1.5A	2A	1A	2A	Peak current	3A	4A
TXA	ALL	ALL	ALL	Optional communication	ALL	ALL
HCB/S	LMC	LMC	LMC	Optional outlet	LMH	LMH
Cable length 2m, 4 cores	Cable length 2m, 12 cores	Cable length 2m, 8 cores	Cable length 2m, 12 cores	Standard outlet specification	Cable length 2m, 12 cores	Cable length 2m, 12 cores

Z-EFG-8S



Features

- 0.1-second closing time
- The force is adjustable in four gears and can be adjusted through the knob
- Long service life: multi cycles, better than pneumatic gripper
- Built-in controller: small footprint, easy to integrate
- Control method: I/O input/output

Specifications

Item	Parameters
Total stroke	8mm (Non-adjustable)
Clamping force	8~20N (Adjustable)
Repeatability	$\pm 0.02\text{mm}$
Recommended clamping weight	$\leq 0.3\text{kg}$
Transmission method	Rack and pinion + cross roller guide
Motion element grease supply	Every six months or one million actions/revolutions
Shortest motion time for one-way stroke	0.1s
Motion mode	Two-finger parallel movement
Weight	0.25kg
Dimensions	30*24*93.9mm
Working voltage	24V $\pm 10\%$
Rated current	0.2A
Peak current	0.6A
Power	5W
Protection level	IP40
Motor type	Servo motor
Temperature range	5~55°C
Humidity range	35~80%RH (Non-condensing)
Outlet specification	5 core cable,length 45cm

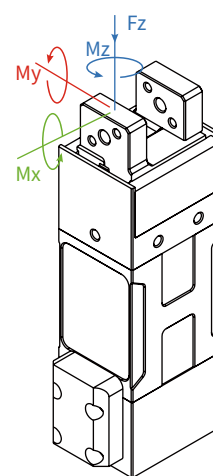

Allowable static load in vertical direction

Fz: 120 N

Allowable payload torque

Mx: 1.6 N·m

My: 1.8 N·m

Mz: 1.5 N·m

Range of motion and dimension

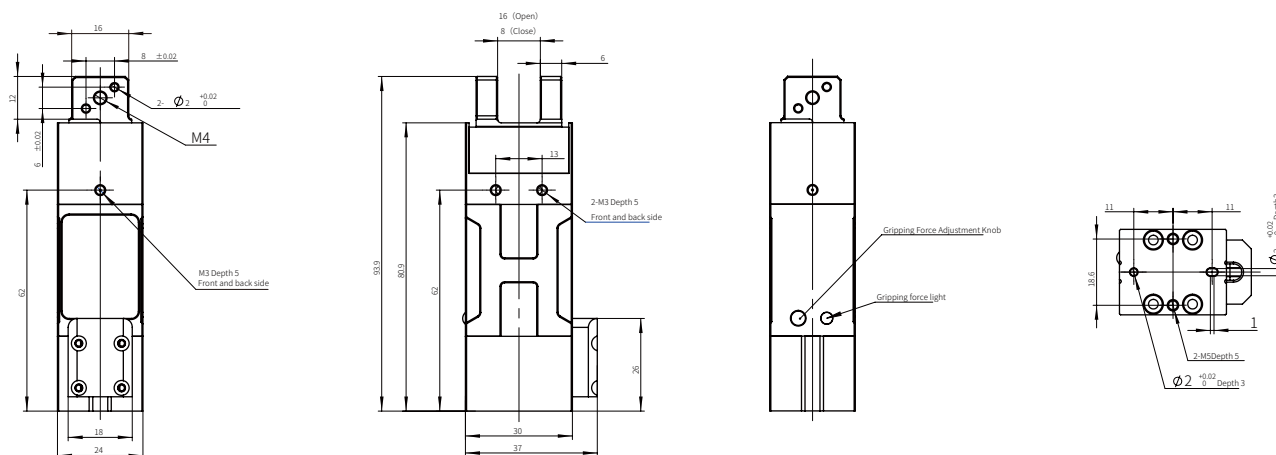

Z-EFG-12



Features

- Fast opening and closing
- Suitable for gripping in small spaces and fragile objects
- Long service life: millions of cycles, better than pneumatic grippers
- Built-in controller: small footprint, easy to interate
- Control method: I/O input and output

Specifications

Item	Parameters
Total Stroke	12mm (Non-adjustable)
Clamping force	30N (Non-adjustable)
Repeatability	±0.02mm
Recommended clamping weight	≤0.5kg
Transmission method	Precision planetary reducer+roller guide
Motion element grease supply	Every six months or one million actions/revolutions
Shortest motion time for one-way stroke	0.2s
Motion mode	Two-finger parallel movement
Weight	0.34kg
Dimensions	48*32*105.6mm
Working voltage	24V±10%
Rated current	0.2A
Peak current	1A
Power	5W
Protection level	IP40
Motor type	Servo motor
Temperature Range	5-55°C
Humidity Range	35-80%RH (Non-condensing)
Outlet specification	5 core cable,length 45cm

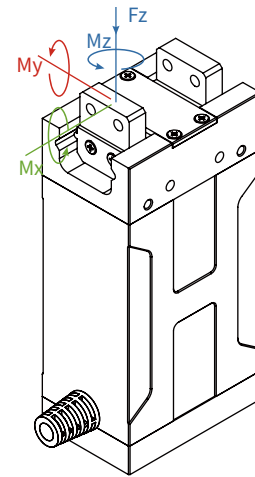

Allowable static load in vertical direction

Fz:	100 N
-----	-------

Allowable payload torque

Mx:	1.3 N·m
My:	1.03 N·m
Mz:	0.95 N·m

Range of motion and dimension

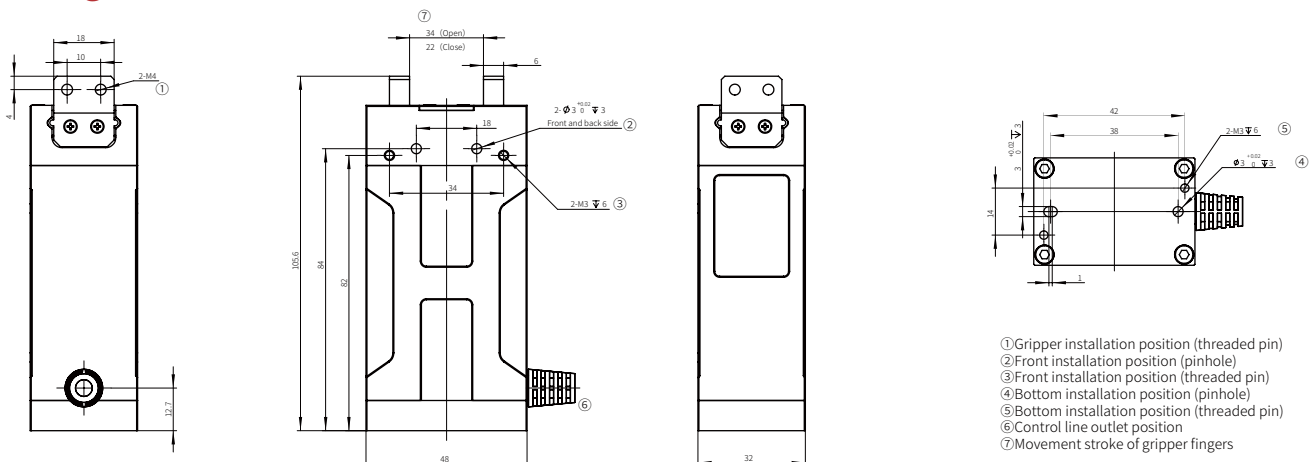

Z-EFG-20



Features

- Large clamping force
- Adjustable stroke and clamping force
- Suitable for gripping in small spaces and fragile objects
- Long service life: millions of cycles, better than pneumatic grippers
- Built-in controller: small footprint, easy to integrate
- Control method: I/O

Specifications

Item	Parameters
Total stroke	20mm (Adjustable)
Clamping force	30-80N (Adjustable)
Repeatability	±0.02mm
Recommended clamping weight	≤0.8kg
Transmission method	Rack and pinion + cross roller guide
Motion element grease supply	Every six months or one million actions/revolutions
Shortest motion time for one-way stroke	0.45s
Motion mode	Two-finger parallel movement
Weight	0.46kg
Dimensions	44*30*124.7mm
Working voltage	24V±10%
Rated current	0.2A
Peak current	1A
Power	5W
Protection level	IP40
Motor type	Servo motor
Temperature range	5-55°C
Humidity range	35-80%RH (Non-condensing)
Outlet specification	5 core cable,length 45cm

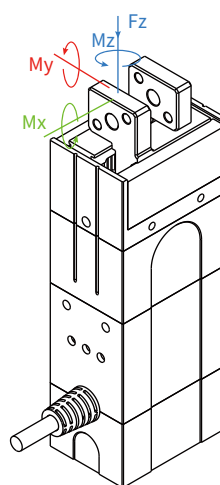

Allowable static load in vertical direction

Fz: 150 N

Allowable payload torque

Mx: 2.1 N·m

My: 2.34 N·m

Mz: 2 N·m

Range of motion and dimension

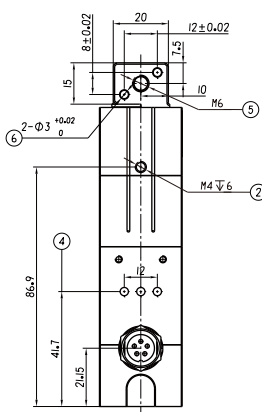
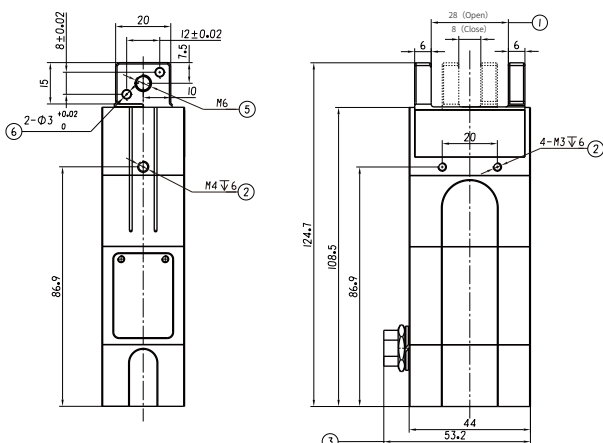

- ① Finger travel distance of the gripper
- ② Side installation position (threaded hole)
- ③ Aviation socket wiring position
- ④ Gripper force adjustment position (left one) and indicator light (right one)
- ⑤ Gripper installation position (threaded hole)
- ⑥ Gripper installation position (pinhole)
- ⑦ Bottom installation position (pinhole)
- ⑧ Bottom installation position (threaded hole)

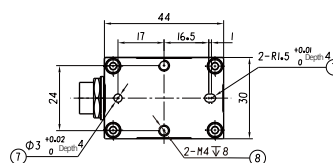

Z-EFG-20P



Features

- Large clamping force
- Adjustable stroke and clamping force
- Long service life: millions of cycles, better than pneumatic grippers
- Built-in controller: small footprint, easy to integrate
- Control method: 485 (Modbus RTU), I/O

Specifications

Item	Parameters
Total stroke	20mm (Adjustable)
Clamping force	30-80N (Adjustable)
Repeatability	±0.02mm
Recommended clamping weight	≤0.8kg
Transmission method	Rack and pinion + cross roller guide
Motion element grease supply	Every six months or one million actions/revolutions
Shortest motion time for one-way stroke	0.4s
Motion mode	Two-finger parallel movement
Weight	0.46kg
Dimensions	44*30*124.7mm
Working voltage	24V±10%
Rated current	0.2A
Peak current	1A
Power	5W
Protection level	IP40
Motor type	Servo motor
Temperature Range	5-55°C
Humidity range	35-80%RH (Non-condensing)
Outlet specification	8 core cable,length 2m

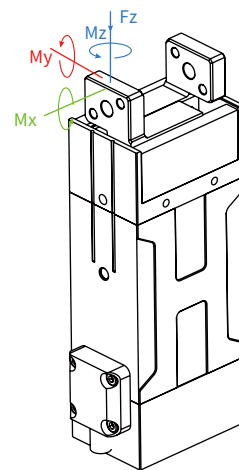

Allowable static load in vertical direction

Fz: 150 N

Allowable payload torque

Mx: 2.1 N·m

My: 2.34 N·m

Mz: 2 N·m

Range of motion and dimension

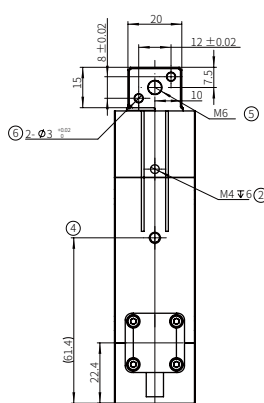
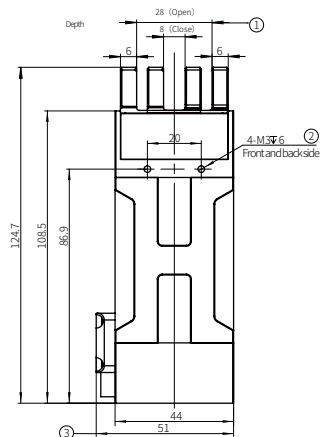
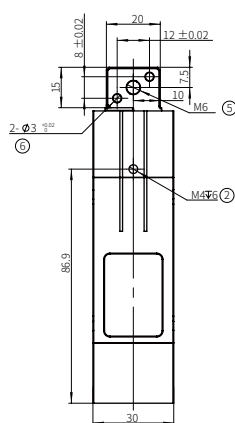

- ① Finger travel distance of the gripper
- ② Side installation position (threaded hole)
- ③ Side cover outlet direction optional
- ④ Indicator position
- ⑤ Fixture mounting position (threaded hole)
- ⑥ Fixture mounting position (pin hole)
- ⑦ Bottom mounting position (pin hole)
- ⑧ Bottom mounting position (threaded hole)

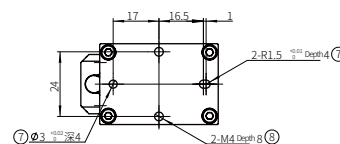

Z-EFG-20F



Features

- High precision force control, $\pm 0.3\text{N}$
- Force, position, and speed can be precisely controlled via Modbus
- Long service life: millions of cycles, better than pneumatic grippers
- Built-in controller: small footprint, easy to integrate
- Control method: 485 (Modbus RTU), I/O

Specifications

Item	Parameters
Total stroke	20mm (Adjustable)
Clamping force	1-8N (Adjustable)
Repeatability	$\pm 0.02\text{mm}$
Recommended clamping weight	$\leq 0.1\text{kg}$
Transmission method	Rack and pinion + linear guide
Motion element grease supply	Every six months or one million actions/revolutions
Shortest motion time for one-way stroke	0.1s
Motion mode	Two-finger parallel movement
Weight	0.5kg
Dimensions	52*32*103mm
Working voltage	24V $\pm 10\%$
Rated current	0.4A
Peak current	1A
Power	10W
Protection level	IP40
Motor type	Servo motor
Temperature range	5-55°C
Humidity range	35-80%RH (Non-condensing)
Outlet specification	8 core cable,length 2m

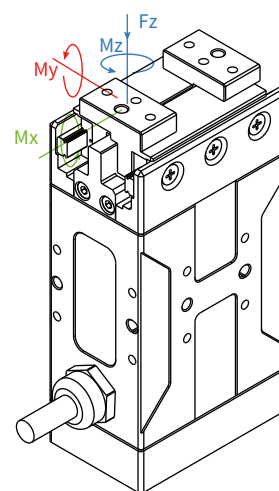

Allowable static load in vertical direction

Fz: 120 N

Allowable payload torque

Mx: 0.6 N·m

My: 1 N·m

Mz: 1 N·m

Range of motion and dimension

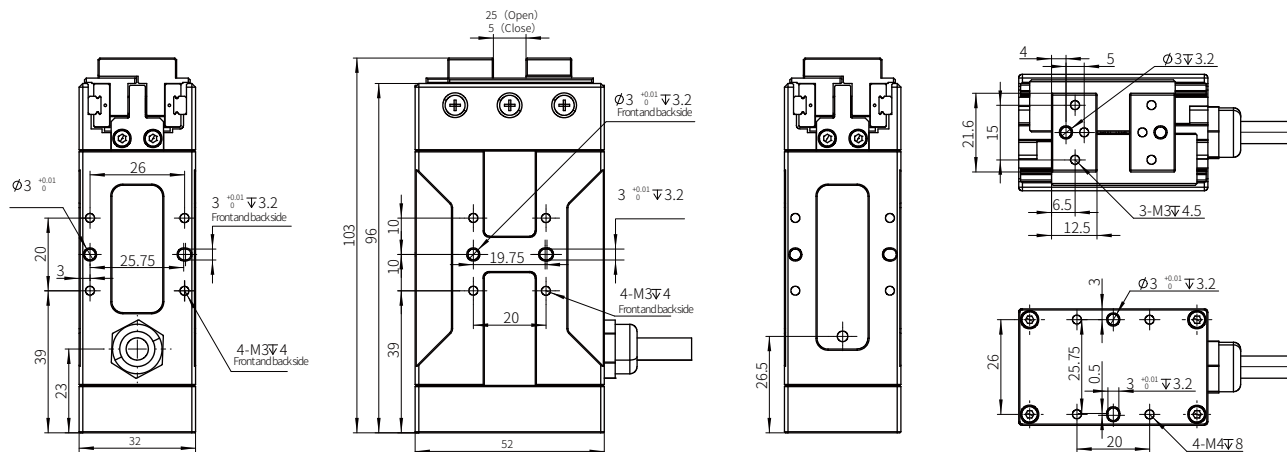

Z-EFG-20S



Features

- 0.15-second closing time
- Four adjustable gripping forces
- Long service life: millions of cycles, better than pneumatic grippers
- Built-in controller: small footprint, easy to integrate
- Control method: I/O input/output

Specifications

Item	Parameters
Total stroke	20mm (Non-adjustable)
Clamping force	8~20N (Adjustable)
Repeatability	±0.02mm
Recommended clamping weight	≤0.3kg
Transmission method	Rack and pinion + cross roller guide
Motion element grease supply	Every six months or one million actions/revolutions
Shortest motion time for one-way stroke	0.15s
Motion mode	Two-finger parallel movement
Weight	0.35kg
Dimensions	43*24*93.9mm
Working voltage	24V±10%
Rated current	0.2A
Peak current	0.6A
Power	5W
Protection level	IP40
Motor type	Servo motor
Temperature range	5~55°C
Humidity range	35~80%RH (Non-condensing)
Outlet specification	5 core cable,length 45cm

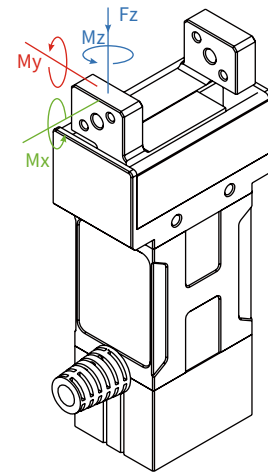

Allowable static load in vertical direction

Fz: 150 N

Allowable payload torque

Mx: 2.1 N·m

My: 2.34 N·m

Mz: 2 N·m

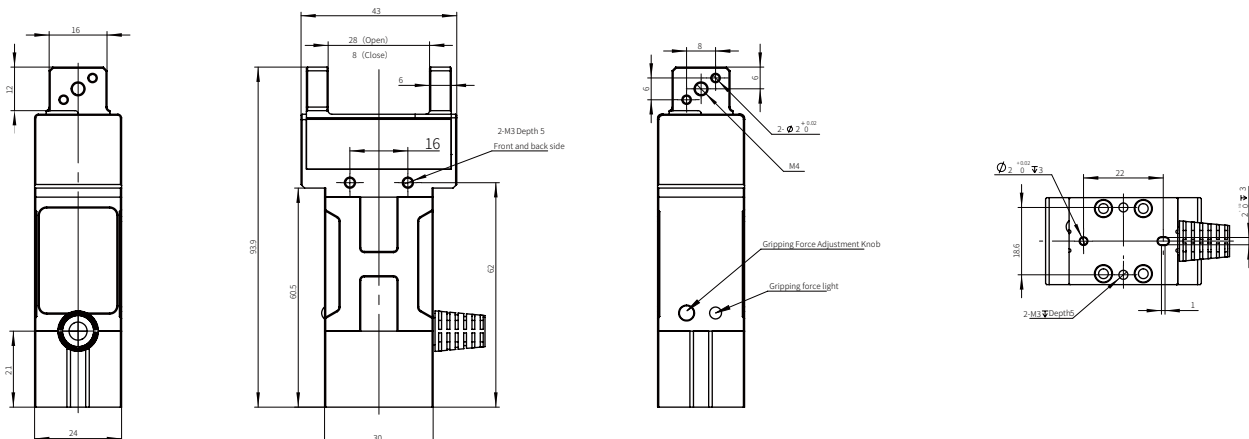

Z-EFG-26



Features

- Clamping dropdown detection, area output function
- Force, position, and speed can be precisely controlled via Modbus
- Long service life: millions of cycles, better than pneumatic grippers
- Built-in controller: small footprint, easy to integrate
- Control method: 485 (Modbus RTU), I/O

Specifications

Item	Parameters
Total stroke	26mm (Adjustable)
Clamping force	6~15N (Adjustable)
Repeatability	$\pm 0.02\text{mm}$
Recommended clamping weight	$\leq 0.3\text{kg}$
Transmission method	Precision planetary gearbox + cross roller guide
Motion element grease supply	Every six months or one million actions/revolutions
Shortest motion time for one-way stroke	0.25s
Motion mode	Two-finger parallel movement
Weight	0.45kg
Dimensions	55*26*97mm
Working voltage	24V $\pm 10\%$
Rated current	0.4A
Peak current	1A
Power	10W
Protection level	IP40
Motor type	Servo motor
Temperature range	5~55°C
Humidity range	35~80%RH (Non-condensing)
Outlet specification	8 core cable,length 2m

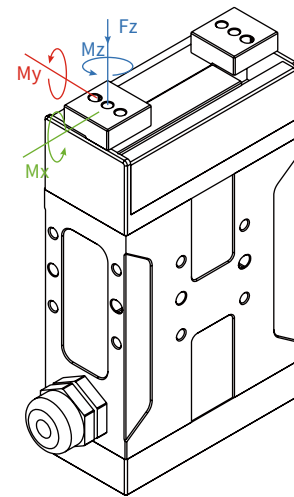

Allowable static load in vertical direction

Fz: 250 N

Allowable payload torque

Mx: 2.4 N·m

My: 2.6 N·m

Mz: 2 N·m

Range of motion and dimension

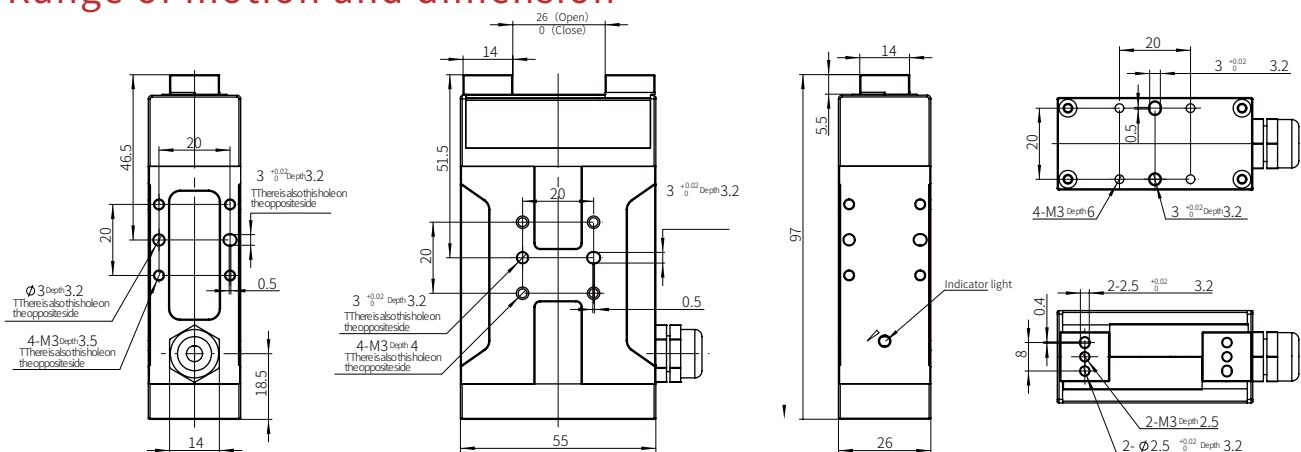

Z-EFG-26P



Features

- Clamping drop detection, area output function
- Force, position, and speed can be precisely controlled via Modbus
- Long service life: millions of cycles, better than pneumatic grippers
- Built-in controller: small footprint, easy to integrate
- Control method: 485 (Modbus RTU), I/O

Specifications

Item	Parameters
Total stroke	26mm (Adjustable)
Clamping force	15-50N (Adjustable)
Repeatability	±0.02mm
Recommended clamping weight	≤0.5kg
Transmission method	Precision planetary gearbox + cross roller guide
Motion element grease supply	Every six months or one million actions/revolutions
Shortest motion time for one-way stroke	0.3s
Motion mode	Two-finger parallel movement
Weight	0.5kg
Dimensions	55*29*103mm
Working voltage	24V±10%
Rated current	0.4A
Peak current	1A
Power	10W
Protection level	IP40
Motor type	Servo motor
Temperature range	5-55°C
Humidity range	35-80%RH (Non-condensing)
Outlet specification	8 core cable,length 2m

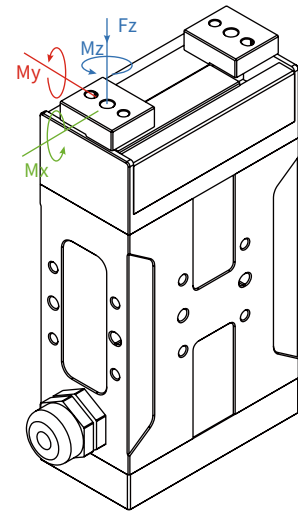

Allowable static load in vertical direction

Fz: 250 N

Allowable payload torque

Mx: 2.4 N·m

My: 2.6 N·m

Mz: 2 N·m

Range of motion and dimension

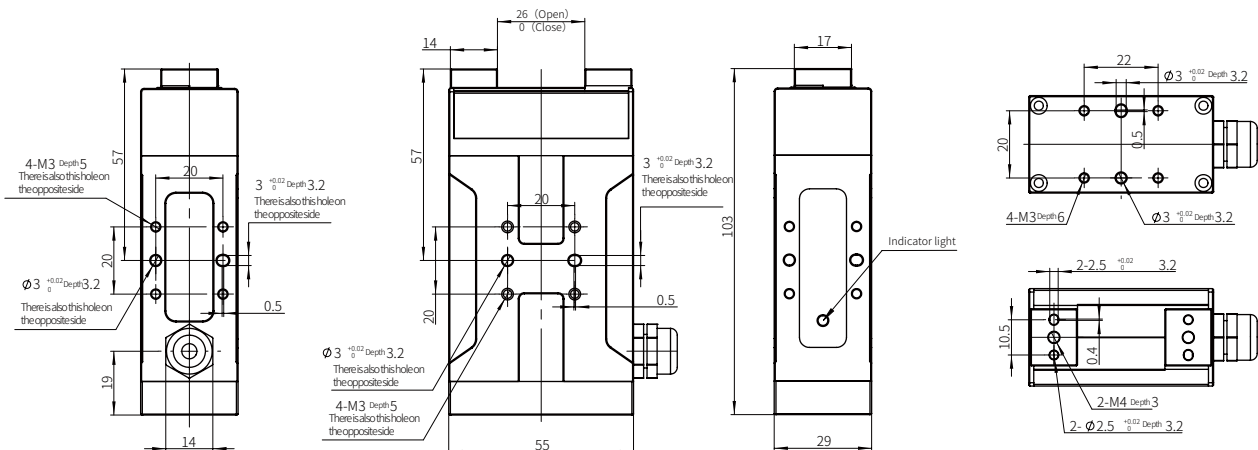

Z-EFG-30



Features

- Clamping drop detection, area output function
- Force, position, and speed can be precisely controlled via Modbus
- Long service life: millions of cycles, better than pneumatic grippers
- Built-in controller: small footprint, easy to integrate
- Control method: 485 (Modbus RTU), I/O

Specifications

Item	Parameters
Total stroke	30mm (Adjustable)
Clamping force	10~40N (Adjustable)
Repeatability	±0.02mm
Recommended clamping weight	≤0.4kg
Transmission method	Rack and pinion + linear guide
Motion element grease supply	Every six months or one million actions/revolutions
Shortest motion time for one-way stroke	0.2s
Motion mode	Two-finger parallel movement
Weight	0.55kg
Dimensions	52*38*108mm
Working voltage	24V±10%
Rated current	0.5A
Peak current	2A
Power	12W
Protection level	IP40
Motor type	Servo motor
Temperature range	5~55°C
Humidity range	35~80%RH (Non-condensing)
Outlet specification	12 core cable,length 2m

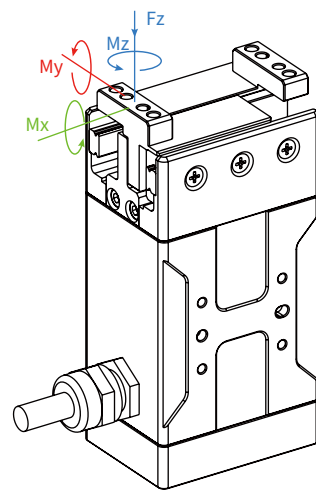

Allowable static load in vertical direction

Fz: 200 N

Allowable payload torque

Mx: 1.6 N·m

My: 1.2 N·m

Mz: 1.2 N·m

Range of motion and dimension

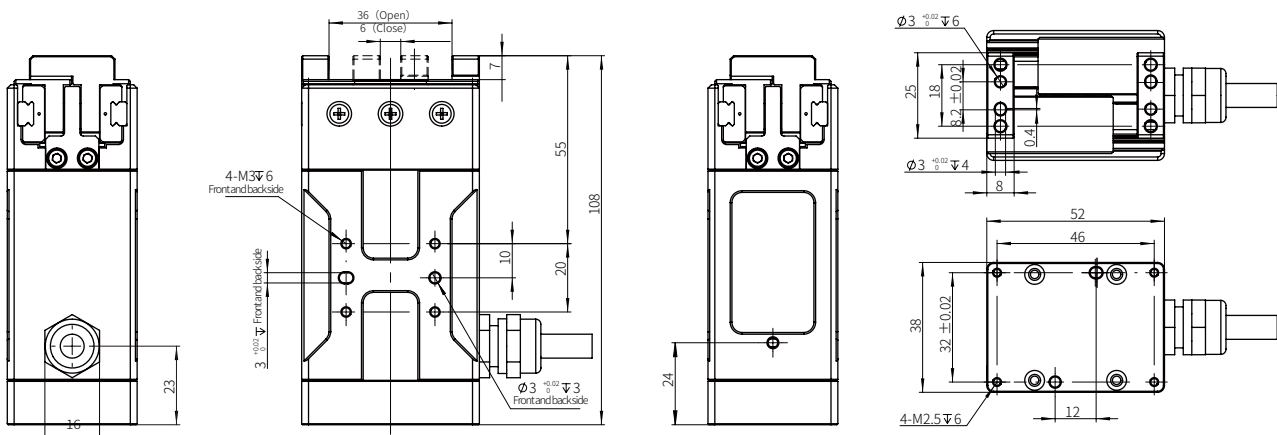

Z-EFG-50



Features

- Clamping drop detection, area output function
- Force, position, and speed can be precisely controlled via Modbus
- Long service life: millions of cycles, better than pneumatic grippers
- Built-in controller: small footprint, easy to integrate
- Control method: 485 (Modbus RTU), I/O

Specifications

Item	Parameters
Total stroke	50mm (Adjustable)
Clamping force	15-50N (Adjustable)
Repeatability	±0.02mm
Recommended clamping weight	≤0.5kg
Transmission method	Rack and pinion + linear guide
Motion element grease supply	Every six months or one million actions/revolutions
Shortest motion time for one-way stroke	0.3s
Motion mode	Two-finger parallel movement
Weight	0.7kg
Dimensions	68*38*108mm
Working voltage	24V±10%
Rated current	0.5A
Peak current	2A
Power	12W
Protection level	IP40
Motor type	Servo motor
Temperature range	5-55°C
Humidity range	35-80%RH (Non-condensing)
Outlet specification	12 core cable,length 2m

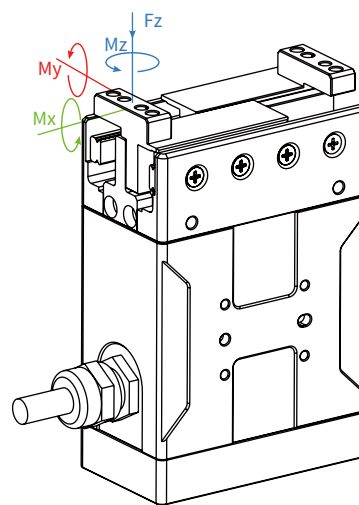

Allowable static load in vertical direction	
Fz:	200 N
Allowable payload torque	
Mx:	1.6 N·m
My:	1.2 N·m
Mz:	1.2 N·m

Range of motion and dimension

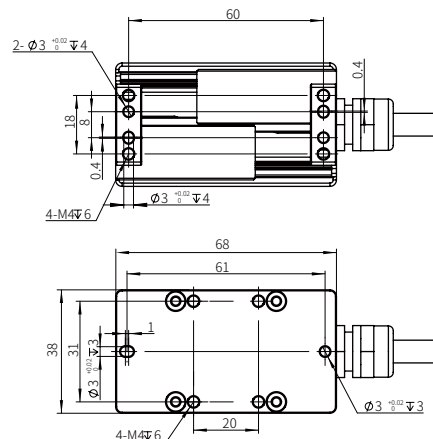
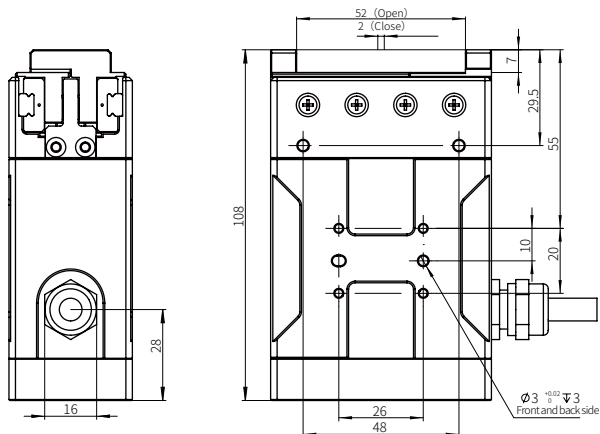

Z-EFG-50P ALL



Features

- Clamping drop detection, area output function
- Force, position, and speed can be precisely controlled via Modbus
- Long service life: millions of cycles, better than pneumatic grippers
- Built-in controller: small footprint, easy to integrate
- Control method: 485 (Modbus RTU), I/O
- Rigid clamping structure and large load allowable torque

Specifications

Item	Parameters
Total stroke	50mm (Adjustable)
Clamping force	15-50N (Adjustable)
Repeatability	±0.02mm
Recommended clamping weight	≤0.5kg
Transmission method	Rack and pinion + ball guide rail
Motion element grease supply	Every six months or one million actions/revolutions
Shortest motion time for one-way stroke	0.3s
Motion mode	Two-finger parallel movement
Weight	1kg
Dimensions	84*38*108mm
Working voltage	24V±10%
Rated current	0.5A
Peak current	2A
Power	12W
Protection level	IP40
Motor type	Servo motor
Temperature range	5-55°C
Humidity range	35-80%RH (Non-condensing)
Outlet specification	12 core cable,length 2m

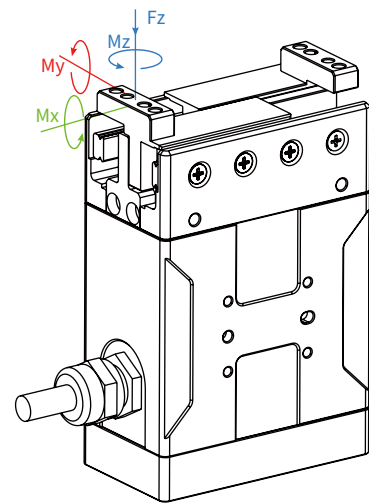

Allowable static load in vertical direction

Fz: 200 N

Allowable payload torque

Mx: 1.6 N·m

My: 1.2 N·m

Mz: 1.2 N·m

Range of motion and dimension

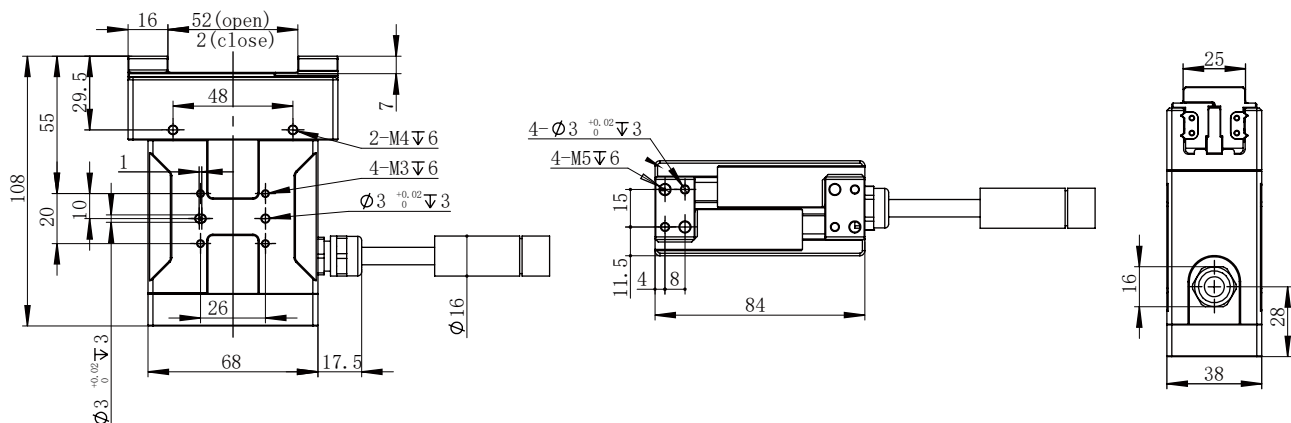

Z-EFG-50P ECT



Features

- Clamping drop detection, area output function
- Force, position, and speed can be precisely controlled via Modbus
- Long service life: millions of cycles, better than pneumatic grippers
- Built-in controller: small footprint, easy to integrate
- Control method: 485 (Modbus RTU), I/O
- Rigid clamping structure and large load allowable torque

Specifications

Item	Parameters
Total stroke	50mm (Adjustable)
Clamping force	15-50N (Adjustable)
Repeatability	±0.02mm
Recommended clamping weight	≤0.5kg
Transmission method	Rack and pinion + ball guide rail
Motion element grease supply	Every six months or one million actions/revolutions
Shortest motion time for one-way stroke	0.3s
Motion mode	Two-finger parallel movement
Weight	1kg
Dimensions	84*38*108mm
Working voltage	24V±10%
Rated current	0.5A
Peak current	2A
Power	12W
Protection level	IP40
Motor type	Servo motor
Temperature range	5-55°C
Humidity range	35-80%RH (Non-condensing)
Outlet specification	5 core cable,length 2m

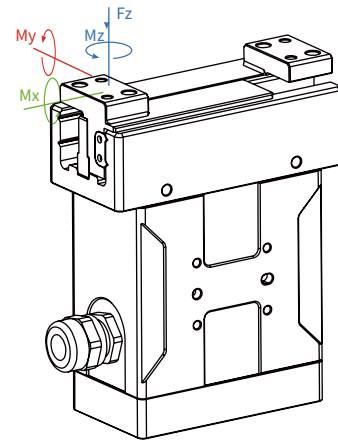

Allowable static load in vertical direction

Fz: 200 N

Allowable payload torque

Mx: 2.0 N·m

My: 2.0 N·m

Mz: 2.0 N·m

Range of motion and dimension

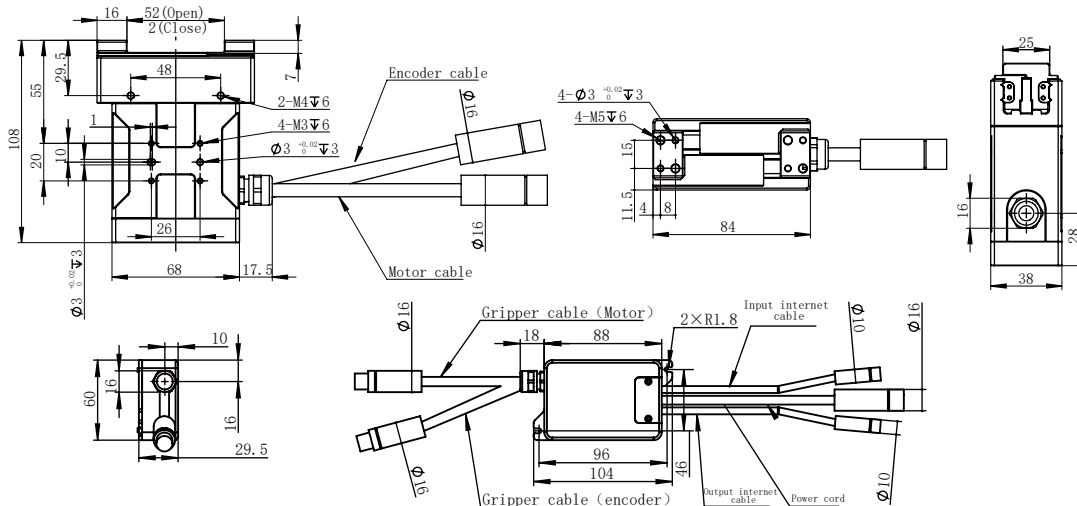

Z-EFG-80



Features

- Clamping drop detection, area output function
- Force, position, and speed can be precisely controlled via Modbus
- Long service life: millions of cycles, better than pneumatic grippers
- Built-in controller: small footprint, easy to integrate
- Control method: 485 (Modbus RTU), I/O
- Rigid clamping structure and large load allowable torque

Specifications

Item	Parameters
Total stroke	80mm (Adjustable)
Clamping force	15-50N (Adjustable)
Repeatability	±0.02mm
Recommended clamping weight	≤0.5kg
Transmission method	Rack and pinion + ball guide rail
Motion element grease supply	Every six months or one million actions/revolutions
Shortest motion time for one-way stroke	0.5s
Motion mode	Two-finger parallel movement
Weight	0.85kg
Dimensions	98*38*108mm
Working voltage	24V±10%
Rated current	0.5A
Peak current	2A
Power	12W
Protection level	IP20
Motor type	Servo motor
Temperature range	5-55°C
Humidity range	35-80%RH (Non-condensing)
Outlet specification	12 core cable,length 2m

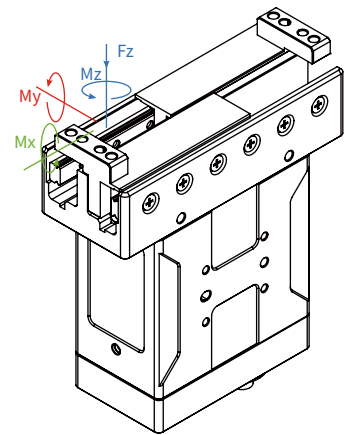

Allowable static load in vertical direction

Fz: 200 N

Allowable payload torque

Mx: 1.6 N·m

My: 1.2 N·m

Mz: 1.2 N·m

Range of motion and dimension

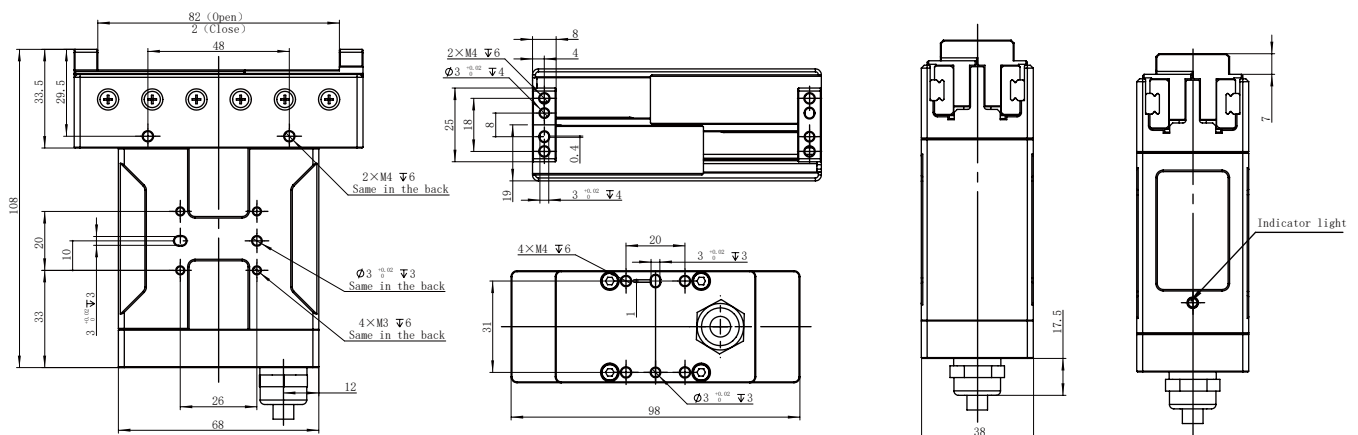

Z-EFG-C35



Features

- Clamping drop detection, area output function
- Force, position, and speed can be precisely controlled via Modbus
- Long service life: millions of cycles, better than pneumatic grippers
- Built-in controller: small footprint, easy to integrate
- Control method: 485 (Modbus RTU), I/O

Specifications

Item	Parameters
Total stroke	35mm (Adjustable)
Clamping force	15-50N (Adjustable)
Repeatability	±0.03mm
Recommended clamping weight	≤1kg
Transmission method	Precision planetary gearbox + cross roller guide
Motion element grease supply	Every six months or one million actions/revolutions
Shortest motion time for one-way stroke	0.5s
Motion mode	Two-finger parallel movement
Weight	0.5kg
Dimensions	63*63*92mm
Working voltage	24V±10%
Rated current	0.3A
Peak current	1A
Power	8W
Protection level	IP54
Motor type	Servo motor
Temperature range	5-55°C
Humidity range	35-80%RH (Non-condensing)
Outlet specification	12 core cable,length 2m

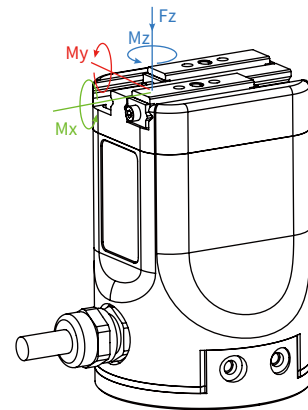

Allowable static load in vertical direction

Fz: 150 N

Allowable payload torque

Mx: 2.5 N·m

My: 2 N·m

Mz: 3 N·m

Range of motion and dimension

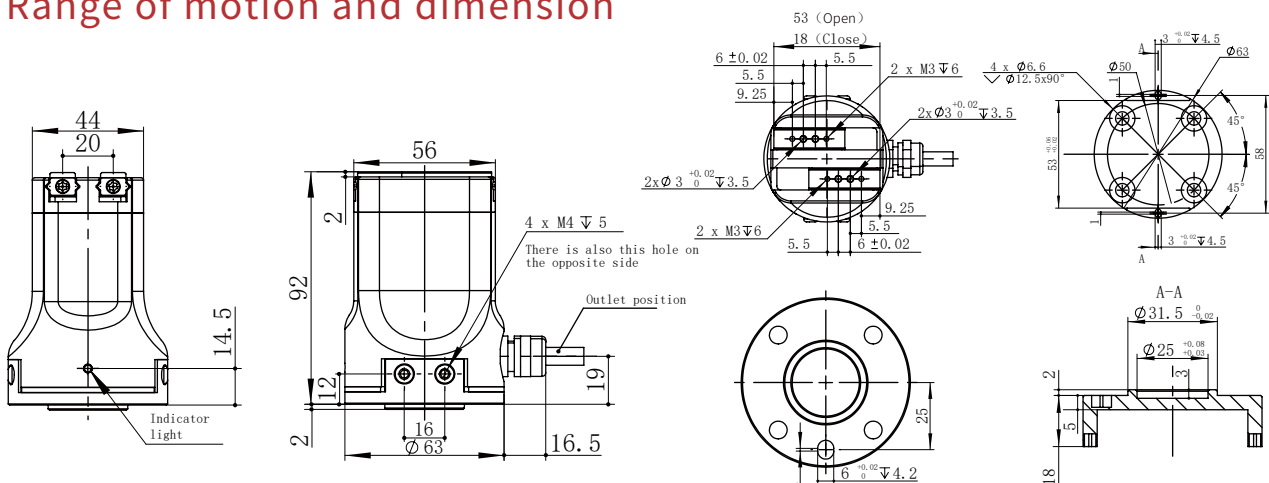

Z-EFG-C50



Features

- Clamping drop detection, area output function
- Force, position, and speed can be precisely controlled via Modbus
- Long service life: millions of cycles, better than pneumatic grippers
- Built-in controller: small footprint, easy to integrate
- Control method: 485 (Modbus RTU), I/O

Specifications

Item	Parameters
Total stroke	50mm (Adjustable)
Clamping force	40-140N (Adjustable)
Repeatability	±0.03mm
Recommended clamping weight	≤2kg
Transmission method	Precision planetary gearbox + cross roller guide
Motion element grease supply	Every six months or one million actions/revolutions
Shortest motion time for one-way stroke	0.5s
Motion mode	Two-finger parallel movement
Weight	1.15kg
Dimensions	72*72*100.5mm
Working voltage	24V±10%
Rated current	0.8A
Peak current	2A
Power	20W
Protection level	IP54
Motor type	Servo motor
Temperature range	5-55°C
Humidity range	35-80%RH (Non-condensing)
Outlet specification	12 core cable,length 2m

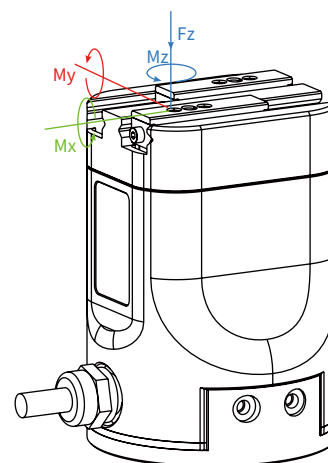

Allowable static load in vertical direction

Fz: 300 N

Allowable payload torque

Mx: 7 N·m

My: 7 N·m

Mz: 7 N·m

Range of motion and dimension

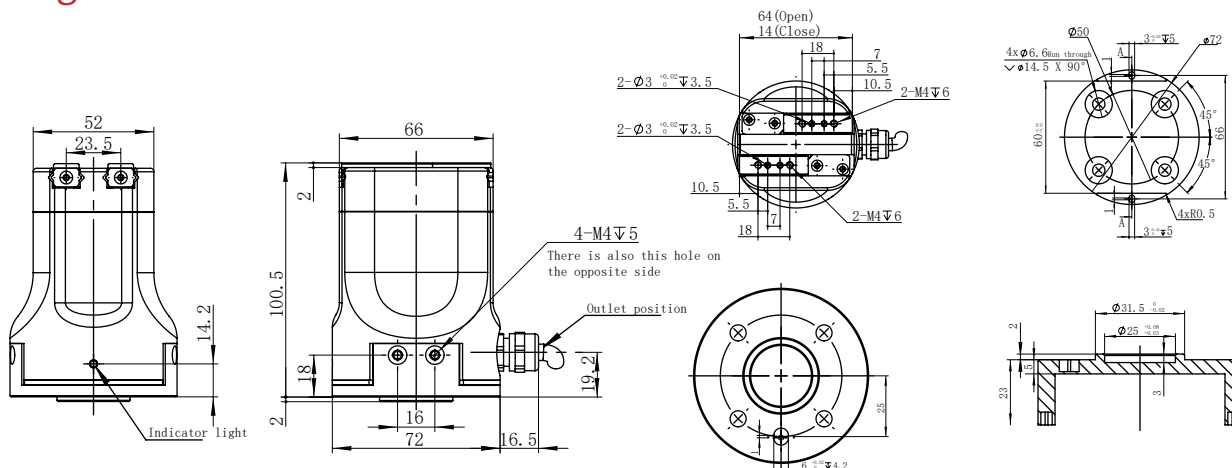

Z-EFG-C65



Features

- Clamping drop detection, area output function
- Force, position, and speed can be precisely controlled via Modbus
- Long service life: millions of cycles, better than pneumatic grippers
- Built-in controller: small footprint, easy to integrate
- Control method: 485 (Modbus RTU), I/O

Specifications

Item	Parameters
Total stroke	65mm (Adjustable)
Clamping force	60-300N (Adjustable)
Repeatability	±0.03mm
Recommended clamping weight	≤6kg
Transmission method	Precision planetary gearbox
Motion element grease supply	Every six months or one million actions/revolutions
Shortest motion time for one-way stroke	0.85s
Motion mode	Two-finger parallel movement
Weight	1.65kg
Dimensions	90°90°115mm
Working voltage	24V±10%
Rated current	0.8A
Peak current	2A
Power	20W
Protection level	IP54
Motor type	Servo motor
Temperature range	5-55°C
Humidity range	35-80%RH (Non-condensing)
Outlet specification	12 core cable,length 2m

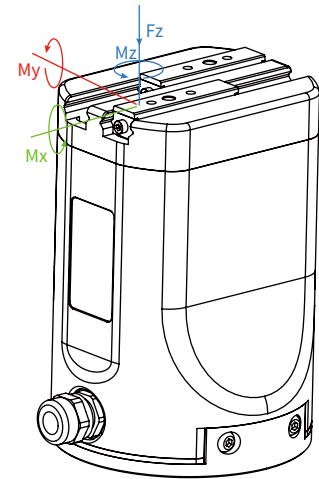

Allowable static load in vertical direction

Fz:	600 N
-----	-------

Allowable payload torque

Mx:	15 N·m
My:	15 N·m
Mz:	15 N·m

Range of motion and dimension

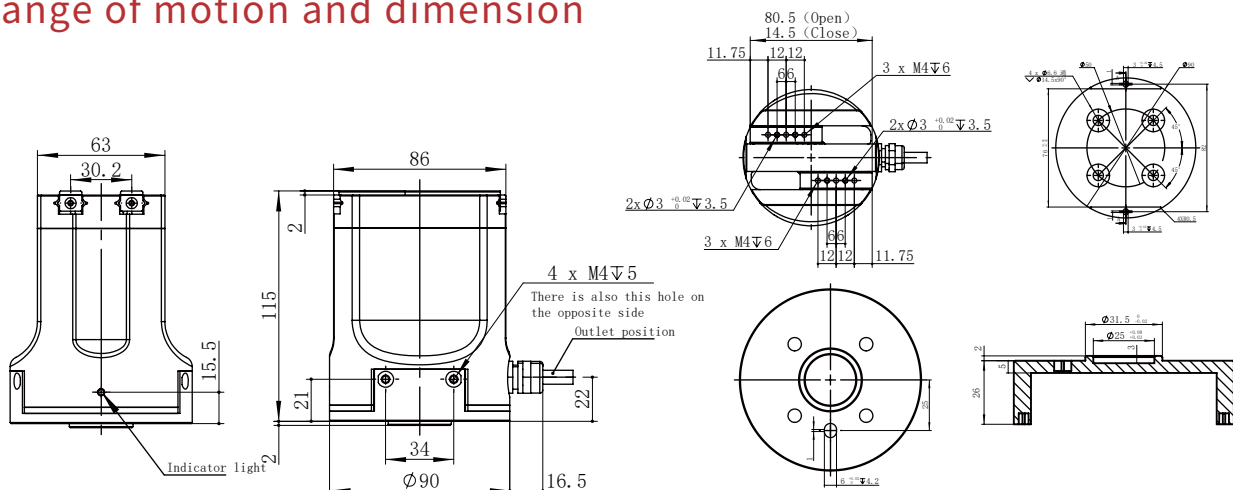

Z-EFG-FS



Features

- Small size, adjustable clamping force
- Suitable for small spaces and fragile objects
- Exclusive for 6-axis robot arm
- Long service life: surpasses pneumatic grippers with millions of cycle times
- Built-in controller: occupies small space, easy to integrate
- Control method: I/O input and output

Specifications

Item	Parameters
Total stroke	8mm (Non-adjustable)
Clamping force	8~20N (Adjustable)
Repeatability	±0.02mm
Recommended clamping weight	≤0.3kg
Transmission method	Rack and pinion + cross roller guide
Motion element grease supply	Every six months or one million actions/revolutions
Shortest motion time for one-way stroke	0.1s
Motion mode	Two-finger parallel movement
Weight	0.3kg
Dimensions	67*67*101.9mm
Working voltage	24V±10%
Rated current	0.2A
Peak current	0.6A
Power	5W
Protection level	IP40
Motor type	Servo motor
Temperature range	5~55°C
Humidity range	35~80%RH (Non-condensing)
Compatible with 6-axis robots	UR, Aubo and other cobots
Outlet specification	5 core cable,length 15cm

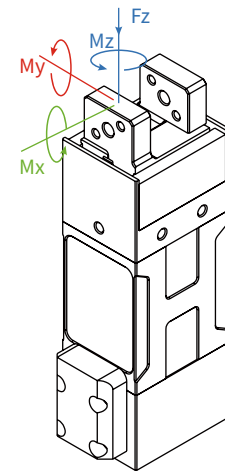

Allowable static load in vertical direction

Fz: 120 N

Allowable payload torque

Mx: 1.6 N·m

My: 1.8 N·m

Mz: 1.5 N·m

Range of motion and dimension

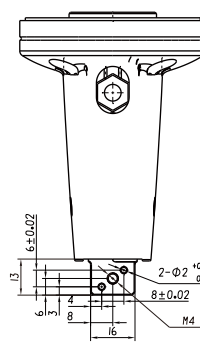
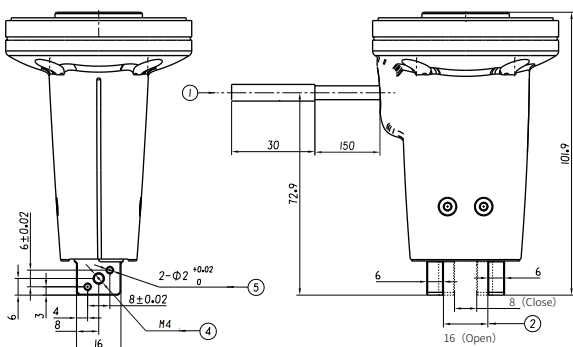

- ①DRKMV8-354
- ②Electric gripper stroke 8mm
- ③Mounting position, connected to the UR robotic arm end flange with 4 M6 screws
- ④ Mounting position for the gripper (M4 screws)
- ⑤Installation position, fixture installation position (∅2Parallel pin hole)

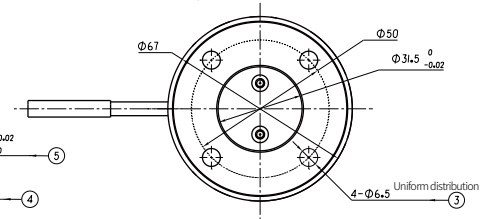

Z-EFG-L



Features

- Fast opening and closing
- Suitable for small spaces and fragile objects
- Exclusive for 6-axis robot arm
- Long service life: surpasses pneumatic grippers with millions of cycle times
- Built-in controller: occupy small space, easy to integrate
- Control method: I/O input and output

Specifications

Item	Parameters
Total stroke	12mm (Non-adjustable)
Clamping force	30N (Adjustable)
Repeatability	$\pm 0.02\text{mm}$
Recommended clamping weight	$\leq 0.5\text{kg}$
Transmission method	Rack and pinion + cross roller guide
Motion element grease supply	Every six months or one million actions/revolutions
Shortest motion time for one-way stroke	0.2s
Motion mode	Two-finger parallel movement
Weight	0.4kg
Dimensions	68*68*113.6mm
Working voltage	24V $\pm 10\%$
Rated current	0.2A
Peak current	1A
Power	5W
Protection level	IP40
Motor type	Servo motor
Temperature range	5-55°C
Humidity range	35-80%RH (Non-condensing)
Compatible with 6-axis robots	UR, Aubo and other robots
Outlet specification	5 core cable,length 15cm

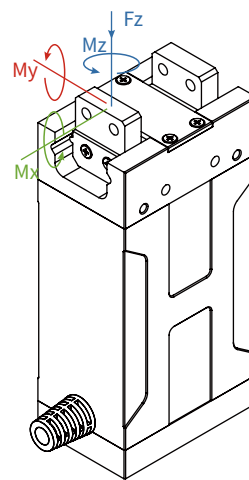

Allowable static load in vertical direction

Fz: 100 N

Allowable payload torque

Mx: 1.3 N·m

My: 1.03 N·m

Mz: 0.95 N·m

Range of motion and dimension

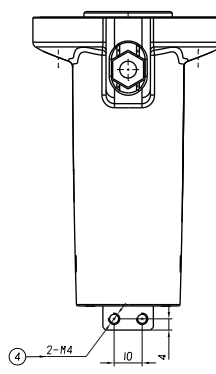
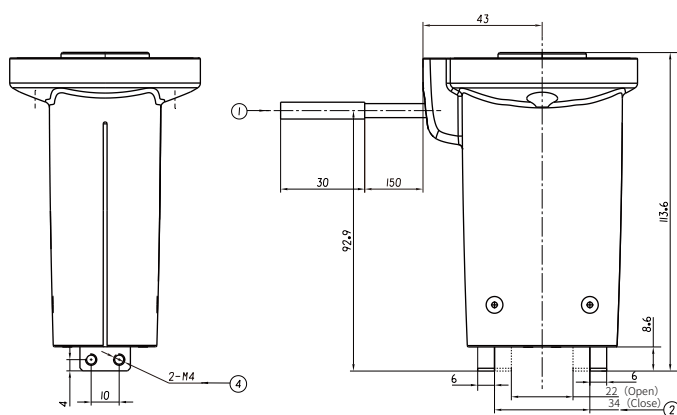

① DRKMV8-354

② Electric gripper with 12mm stroke

③ Mounting position, connected to the UR robotic arm end flange with 2 M6 screws

④ Mounting position for the gripper

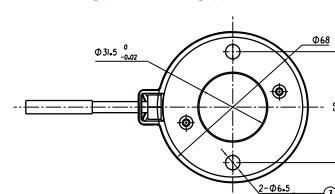

Z-EFG-R



Features

- Large clamping force
- Adjustable clamping force and stroke
- Exclusive for 6-axis robot arm
- Long service life: surpasses pneumatic grippers with millions of cycle times
- Built-in controller: occupies small space, easy to integrate
- Control method: 485 (Modbus RTU), I/O

Specifications

Item	Parameters
Total stroke	20mm (Adjustable)
Clamping force	30-80N (Adjustable)
Repeatability	±0.02mm
Recommended clamping weight	≤0.8kg
Transmission method	Rack and pinion + cross roller guide
Motion element grease supply	Every six months or one million actions/revolutions
Shortest motion time for one-way stroke	0.45s
Motion mode	Two-finger parallel movement
Weight	0.5kg
Dimensions	68*68*132.7mm
Working voltage	24V±10%
Rated current	0.2A
Peak current	1A
Power	5W
Protection level	IP40
Motor type	Servo motor
Temperature range	5-55°C
Humidity range	35-80%RH (Non-condensing)
Compatible with 6-axis robots	UR, Aubo and other cobots
Outlet specification	5 core cable,length 15cm

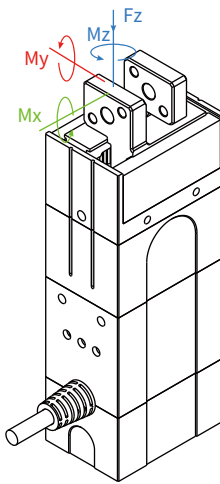

Allowable static load in vertical direction

Fz: 150 N

Allowable payload torque

Mx: 2.1 N·m

My: 2.34 N·m

Mz: 2 N·m

Range of motion and dimension

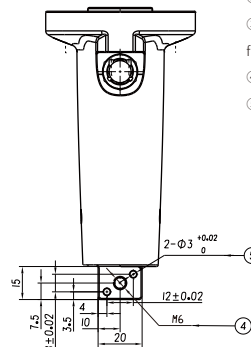
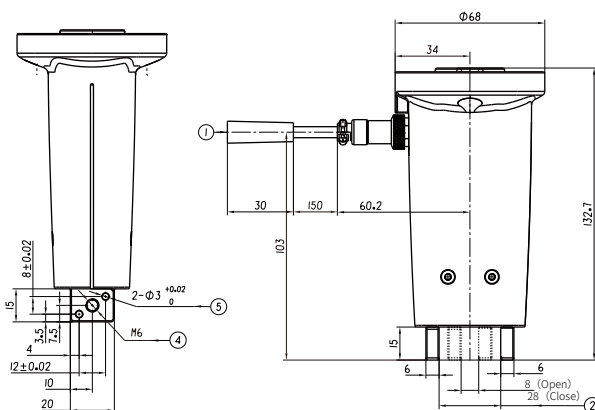

- ① 5-core aviation connector RKMV8-354
- ② Electric gripper with 20mm stroke
- ③ Mounting position, connected to the UR robotic arm end flange with 2 M6 screws
- ④ Mounting position for the gripper (M6 screws)
- ⑤ Mounting position for the gripper (Ø3 cylindrical pin hole)

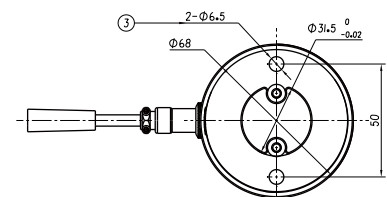

Z-EFG-RP



Features

- Large clamping force
- Adjustable clamping force and stroke
- Exclusive 20mm stroke electric gripper for 6-axis robot arm
- Long service life: surpasses pneumatic grippers with millions of cycle times
- Built-in controller: occupies small space, easy to integrate
- Control method: I/O input and output

Specifications

Item	Parameters
Total stroke	20mm (Adjustable)
Clamping force	30-80N (Adjustable)
Repeatability	±0.02mm
Recommended clamping weight	≤0.8kg
Transmission method	Rack and pinion + cross roller guide
Motion element grease supply	Every six months or one million actions/revolutions
Shortest motion time for one-way stroke	0.4s
Motion mode	Two-finger parallel movement
Weight	0.5kg
Dimensions	68*68*132.7mm
Working voltage	24V±10%
Rated current	0.2A
Peak current	1A
Power	5W
Protection level	IP40
Motor type	Servo motor
Temperature range	5-55°C
Humidity range	35-80%RH (Non-condensing)
Compatible with 6-axis robots	UR, Aubo and other cobots
Outlet specification	5 core cable,length 15cm

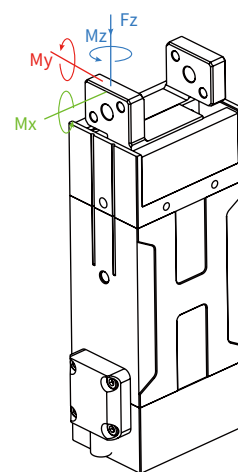

Allowable static load in vertical direction

Fz: 150 N

Allowable payload torque

Mx: 2.1 N·m

My: 2.34 N·m

Mz: 2 N·m

Range of motion and dimension

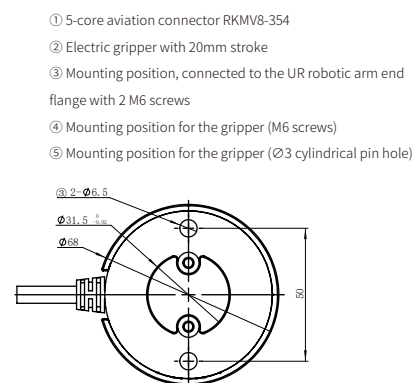
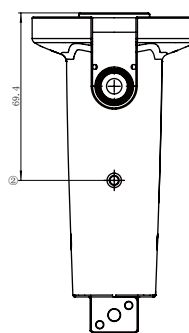
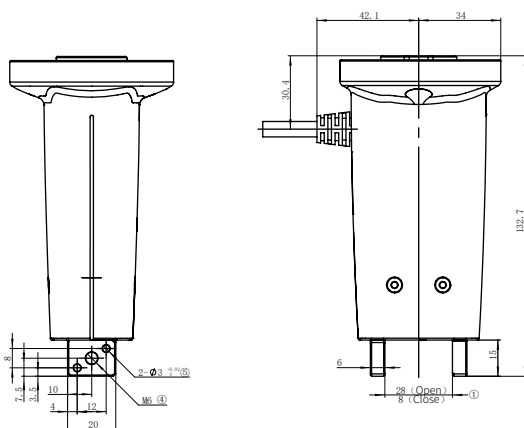

① 5-core aviation connector RKMV8-354

② Electric gripper with 20mm stroke

③ Mounting position, connected to the UR robotic arm end flange with 2 M6 screws

④ Mounting position for the gripper (M6 screws)

⑤ Mounting position for the gripper (∅3 cylindrical pin hole)

Z-EFG-40-100

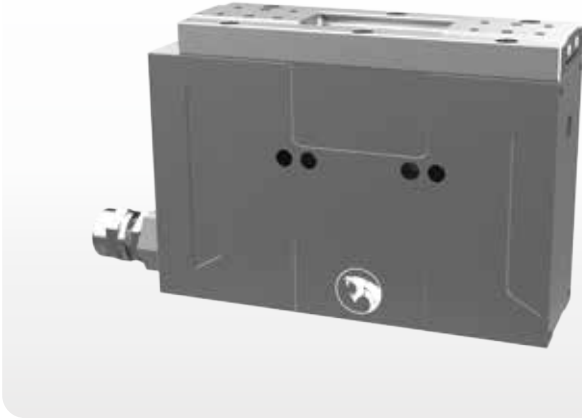

Features

- Large clamping force, power-off locking
- Adjustable clamping force and stroke
- Long service life: millions of cycles, better than pneumatic grippers
- Built-in controller: small footprint, easy to integrate
- Control method: 485 (Modbus RTU), I/O

Specifications

Item	Parameters
Total stroke	40mm (Adjustable)
Clamping force	30-200N (Adjustable)
Repeatability	±0.02mm
Recommended clamping weight	≤1kg
Transmission method	Screw + synchronous belt + ball guide
Motion element grease supply	Every six months or one million actions/revolutions
Shortest motion time for one-way stroke	0.4s
Motion mode	Two-finger parallel movement
Weight	1kg
Dimensions	119*37*85mm
Working voltage	24V±10%
Rated current	0.5A
Peak current	4A
Power	12W
Protection level	IP40
Motor type	Servo motor
Temperature range	5~55°C
Humidity range	35-80%RH (Non-condensing)
Outlet specification	12 core cable,length 2m

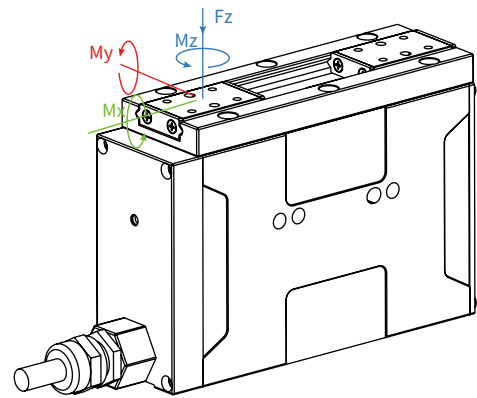

Allowable static load in vertical direction	
Fz:	200 N
Allowable payload torque	
Mx:	8 N·m
My:	6.1 N·m
Mz:	6.1 N·m

Range of motion and dimension

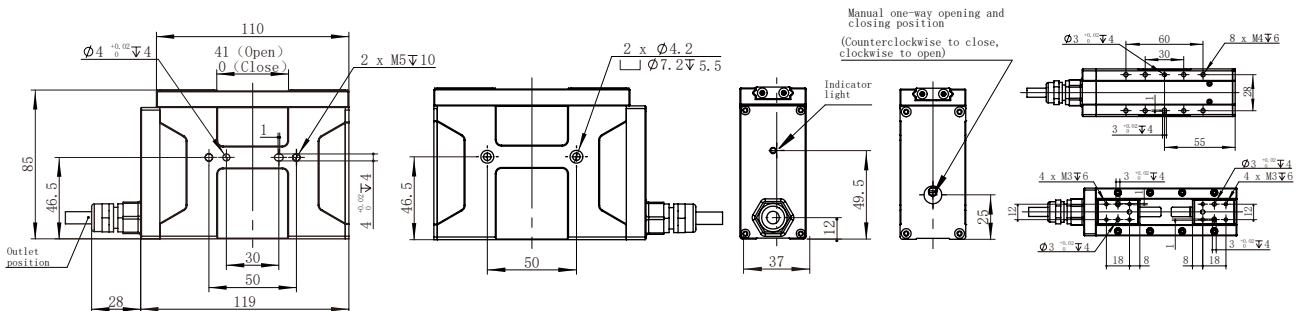

Z-EFG-60-150



Features

- Large clamping force, power-off locking
- Adjustable clamping force and stroke
- Long service life: millions of cycles, better than pneumatic grippers
- Built-in controller: small footprint, easy to integrate
- Control method: 485 (Modbus RTU), I/O

Specifications

Item	Parameters
Total stroke	60mm (Adjustable)
Clamping force	40-300N (Adjustable)
Repeatability	±0.02mm
Recommended clamping weight	≤1.5kg
Transmission method	Screw + synchronous belt + ball guide
Motion element grease supply	Every six months or one million actions/revolutions
Shortest motion time for one-way stroke	0.6s
Motion mode	Two-finger parallel movement
Weight	1.7kg
Dimensions	140*47*112mm
Working voltage	24V±10%
Rated current	1A
Peak current	8A
Power	30W
Protection level	IP40
Motor type	Servo motor
Temperature range	5-55°C
Humidity range	35-80%RH (Non-condensing)
Outlet specification	12 core cable,length 2m

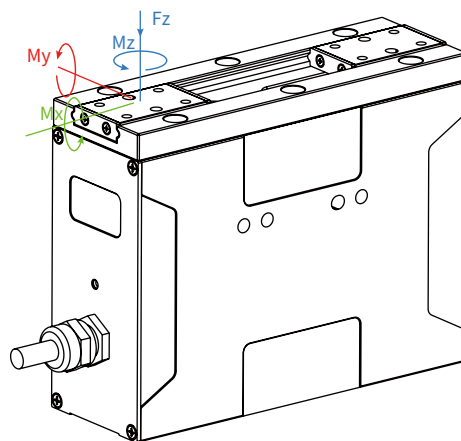

Allowable static load in vertical direction

Fz: 250 N

Allowable payload torque

Mx: 58.5 N·m

My: 15 N·m

Mz: 25.5 N·m

Range of motion and dimension

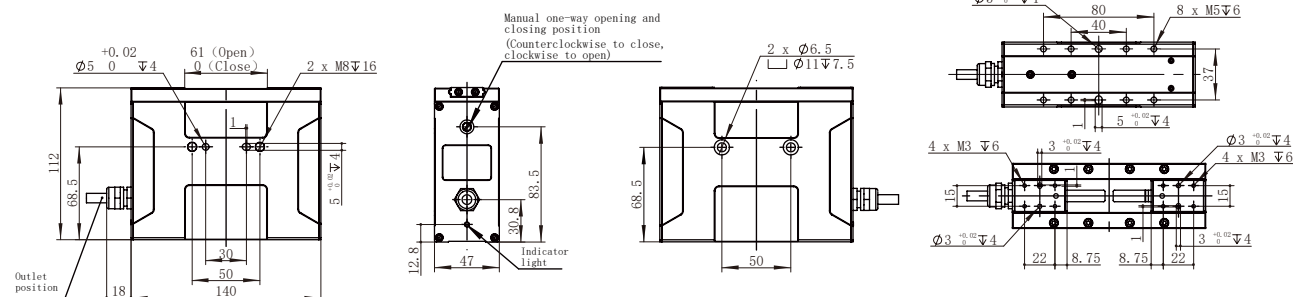

Z-EFG-80-200



Features

- Large clamping force
- Force, position, and speed can be precisely controlled via Modbus
- Long service life: millions of cycles, better than pneumatic grippers
- Built-in controller: small footprint, easy to integrate
- Control method: 485 (Modbus RTU), I/O

Specifications

Item	Parameters
Total stroke	80mm (Adjustable)
Clamping force	60-400N (Adjustable)
Repeatability	±0.02mm
Recommended clamping weight	≤2kg
Transmission method	Screw + synchronous belt + ball guide
Motion element grease supply	Every six months or one million actions/revolutions
Shortest motion time for one-way stroke	0.8s
Motion mode	Two-finger parallel movement
Weight	2kg
Dimensions	172*50*105mm
Working voltage	24V±10%
Rated current	1A
Peak current	8A
Power	30W
Protection level	IP40
Motor type	Servo motor
Temperature range	5-55°C
Humidity range	35-80%RH (Non-condensing)
Outlet specification	12 core cable,length 2m

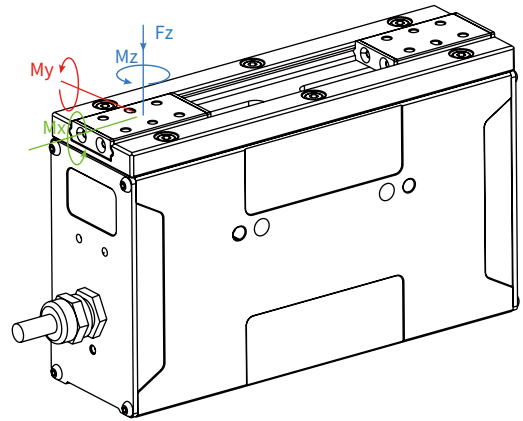

Allowable static load in vertical direction

Fz: 250 N

Allowable payload torque

Mx: 58.5 N·m

My: 15 N·m

Mz: 25.5 N·m

Range of motion and dimension

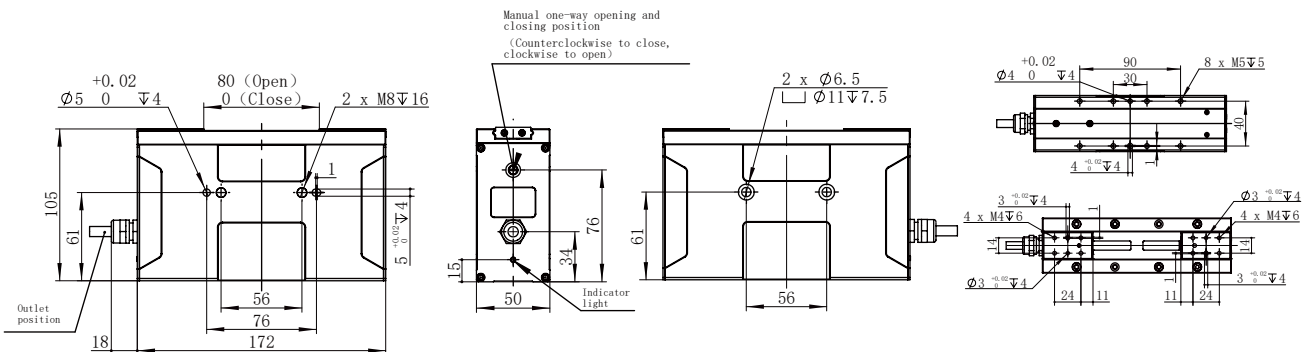

Z-EFG-100

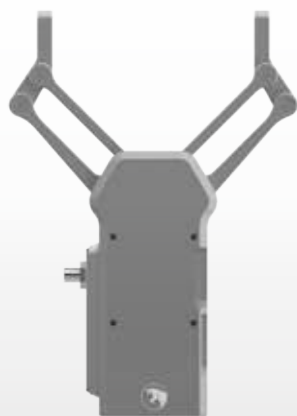

Features

- Adjustable clamping force and stroke
- Long service life: over 10 million cycles, better than pneumatic grippers
- Built-in controller: small footprint and easy to integrate
- Control method: 485 communication

Specifications

Item	Parameters
Total stroke	90mm (Adjustable)
Clamping force	35-60N (Adjustable)
Repeatability	±0.02mm
Recommended clamping weight	≤0.5kg
Transmission method	Lead screw + linkage mechanism
Motion element grease supply	Every six months or one million actions/revolutions
Shortest motion time for one-way stroke	1s
Motion mode	Two finger swing
Weight	0.93kg
Dimensions	203*144*45mm (Open) 222*64*45mm (Close)
Working voltage	24V±10%
Rated current	0.3A
Peak current	1.5A
Power	12W
Protection level	IP40
Motor type	Servo motor
Temperature range	5-55°C
Humidity range	35-80%RH (Non-condensing)
Outlet specification	4 core cable,length 2m

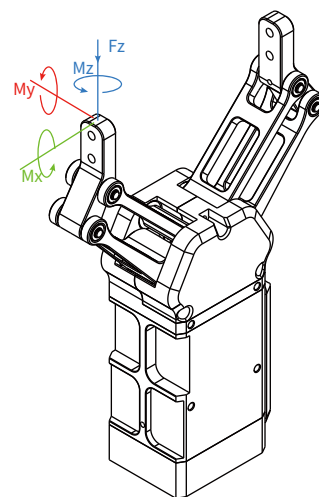

Allowable static load in vertical direction

Fz: 150 N

Allowable payload torque

Mx: 2 N·m

My: 1.5 N·m

Mz: 1.5 N·m

Range of motion and dimension

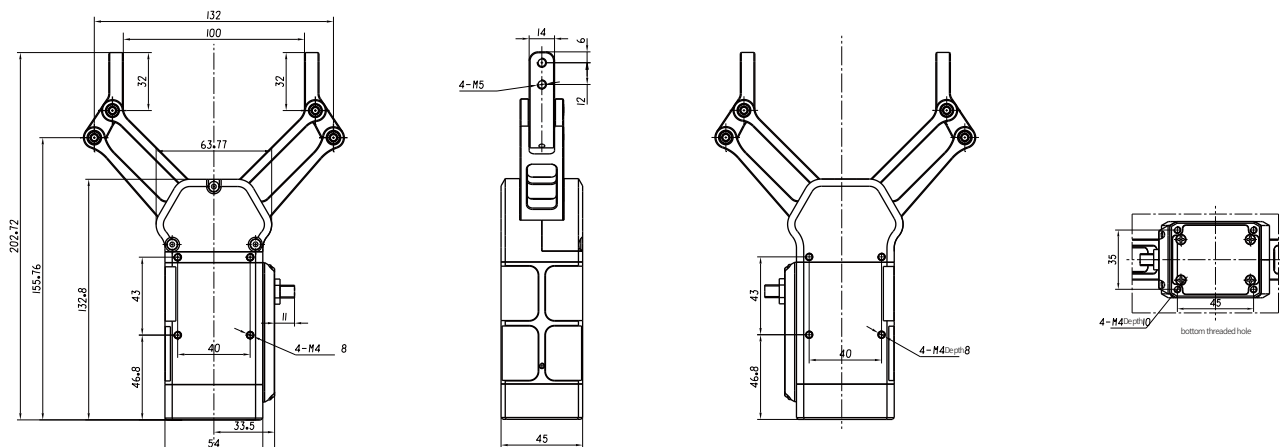

Z-EFG-130



Features

- Adjustable clamping force and stroke
- Long service life: over 10 million cycles, better than pneumatic grippers
- Built-in controller: small footprint and easy to integrate
- Control method: 485 communication I/O

Specifications

Item	Parameters
Total stroke	130mm (Adjustable)
Clamping force	40-130N (Adjustable)
Repeatability	±0.02mm
Recommended clamping weight	≤1kg
Transmission method	Lead screw + linkage mechanism
Motion element grease supply	Every six months or one million actions/revolutions
Shortest motion time for one-way stroke	0.9s
Motion mode	Two finger swing
Weight	0.8kg
Dimensions	171*187*40mm (Open) 218*66.5*40mm (Close)
Working voltage	24V±10%
Rated current	0.4A
Peak current	2A
Power	10W
Protection level	IP40
Motor type	Servo motor
Temperature range	5~55°C
Humidity range	35~80%RH (Non-condensing)
Outlet specification	12 core cable,length 2m

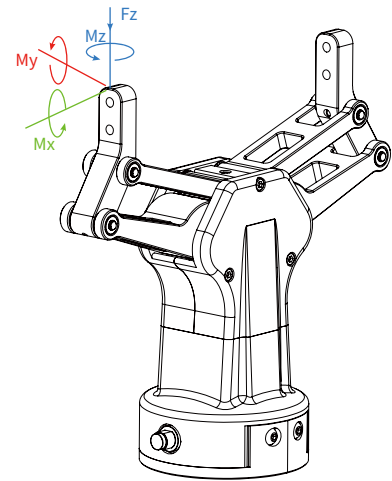

Allowable static load in vertical direction

Fz: 200 N

Allowable payload torque

Mx: 2 N·m

My: 2 N·m

Mz: 2 N·m

Range of motion and dimension

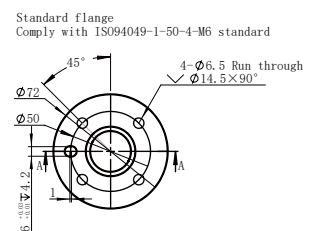
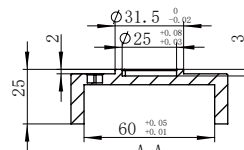
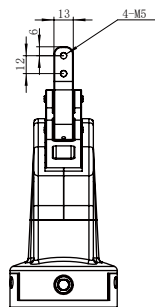
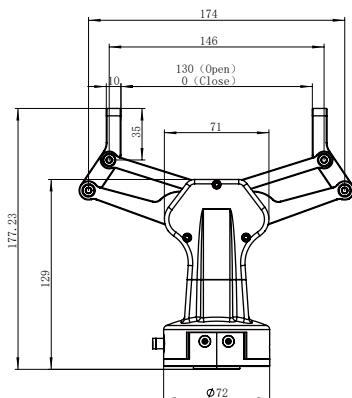

Z-ECG-10



Features

- Clamping drop detection and area output function
- Force, position, and speed can be controlled precisely through Modbus
- Three-finger centralized gripper
- Built-in controller: small footprint and easy to integrate
- Control method: 485 (Modbus RTU), I/O

Specifications

Item	Parameters
Total stroke	10mm (Adjustable)
Clamping force	3-10N (Adjustable)
Repeatability	±0.03mm
Recommended clamping weight	≤0.2kg
Transmission method	Precise planetary reducer + ball guide
Motion element grease supply	Every six months or one million actions/revolutions
Shortest motion time for one-way stroke	0.3s
Motion mode	three-finger parallel movement
Weight	0.5kg
Dimensions	73*73*95.5mm
Working voltage	24V±10%
Rated current	0.3A
Peak current	0.6A
Power	10W
Protection level	IP40
Motor type	Servo motor
Temperature range	5-55°C
Humidity range	35-80%RH (Non-condensing)
Outlet specification	8 core cable,length 2m

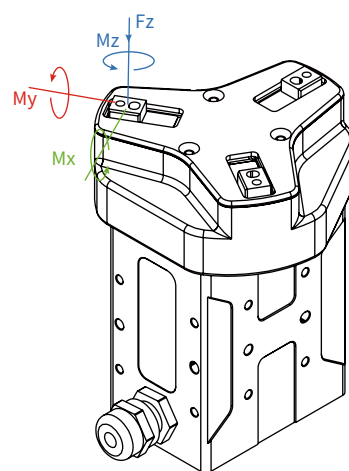

Allowable static load in vertical direction

Fz: 70 N

Allowable payload torque

Mx: 0.64 N·m

My: 0.4 N·m

Mz: 0.48 N·m

Range of motion and dimension

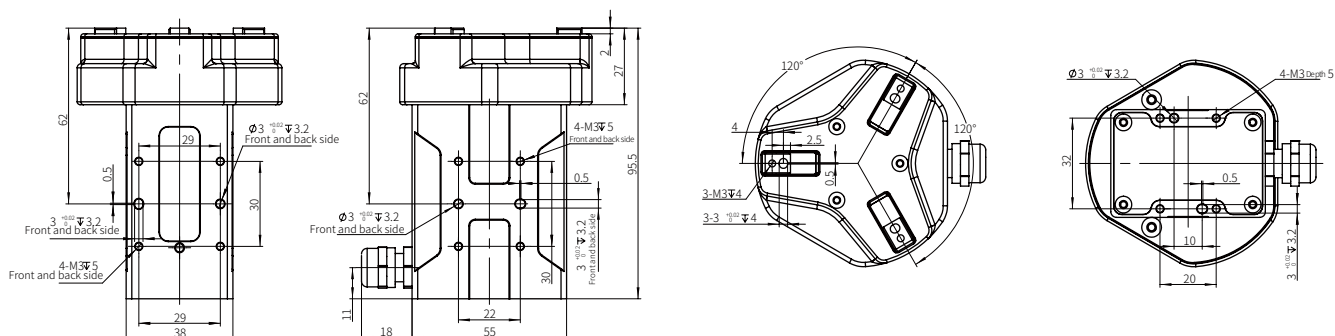

Z-ECG-20



Features

- Clamping drop detection and area output function
- Force, position, and speed can be controlled precisely through Modbus
- Three-finger centralized gripper
- Built-in controller: small footprint and easy to integrate
- Control method: 485 (Modbus RTU), I/O

Specifications

Item	Parameters
Total stroke	20mm (Adjustable)
Clamping force	30-80N (Adjustable)
Repeatability	±0.03mm
Recommended clamping weight	≤1kg
Transmission method	Precise planetary reducer + ball guide
Motion element grease supply	Every six months or one million actions/revolutions
Shortest motion time for one-way stroke	0.5s
Motion mode	three-finger parallel movement
Weight	1.5kg
Dimensions	114*124.5*114mm
Working voltage	24V±10%
Rated current	0.8A
Peak current	2A
Power	20W
Protection level	IP67
Motor type	Servo motor
Temperature range	5-55°C
Humidity range	35-80%RH (Non-condensing)
Outlet specification	12 core cable,length 2m

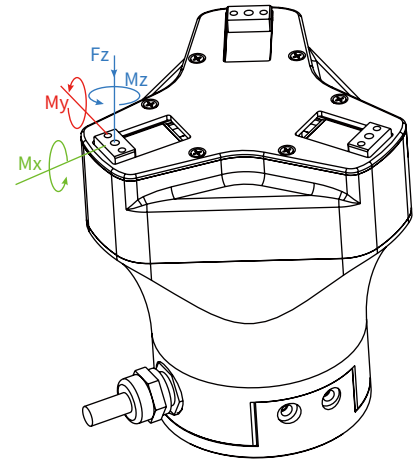

Allowable static load in vertical direction	
Fz:	150 N

Allowable payload torque	
Mx:	1.5 N·m
My:	1.5 N·m
Mz:	1.5 N·m

Range of motion and dimension

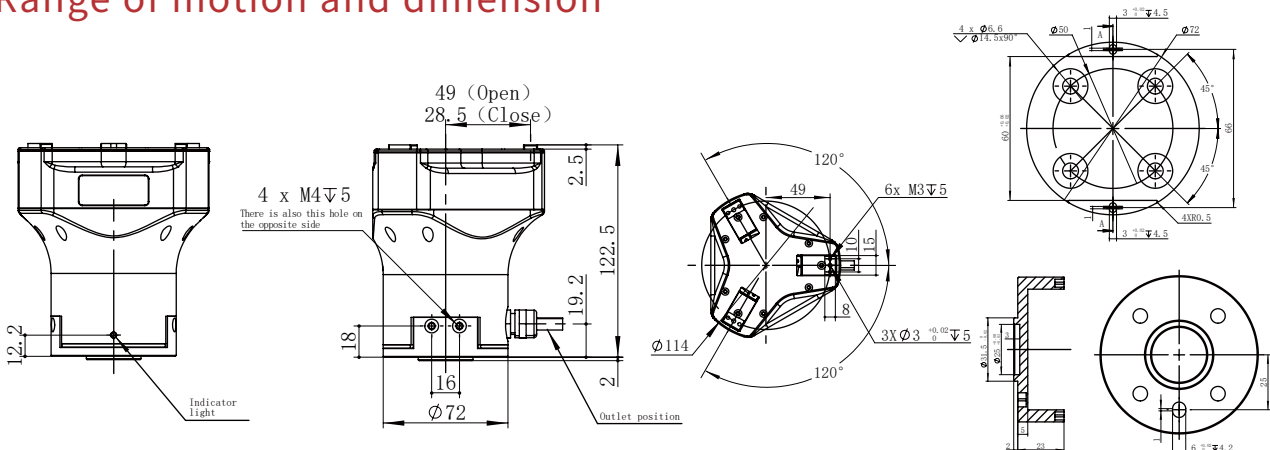

Z-ERG-20-100



Features

- Supports unlimited rotation and relative rotation, no slip rings, low maintenance cost
- Rotation and gripping force, position, and speed can be precisely controlled
- Maximum gripping force of 100N, maximum rotation torque of 1.5N·m
- Long service life: over 10 million cycles, better than pneumatic grippers
- Built-in controller: small footprint and easy to integrate
- Control method: supports Modbus bus control, I/O control

Specifications

Item	Parameters
Total stroke	20mm (Adjustable)
Clamping force	30-100N (Adjustable)
Repeatability	±0.2mm
Recommended clamping weight	≤1kg
Transmission method	Precise planetary reducer+ cross roller guide
Motion element grease supply	Every six months or one million actions/revolutions
Shortest motion time for one-way stroke	0.3s
Maximum rotation torque	1.5 N·m
Maximum rotation speed	180 RPM
Rotation range	Infinite rotation
Rotation clearance	±1°
Weight	1.2kg
Dimensions	54*54*170mm
Working voltage	24V±10%
Rated current	2A
Peak current	4A
Power	50W
Protection level	IP40
Motor type	Servo motor
Temperature range	5-55°C
Humidity range	35-80%RH (Non-condensing)
Outlet specification	12 core cable,length 2m

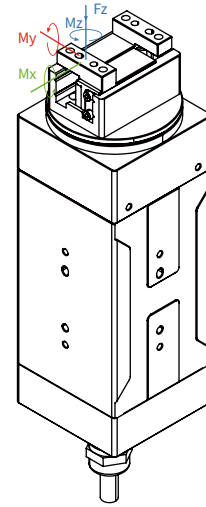

Allowable static load in vertical direction

Fz: 150 N

Allowable payload torque

Mx: 1.6 N·m

My: 1.8 N·m

Mz: 1.6 N·m

Range of motion and dimension

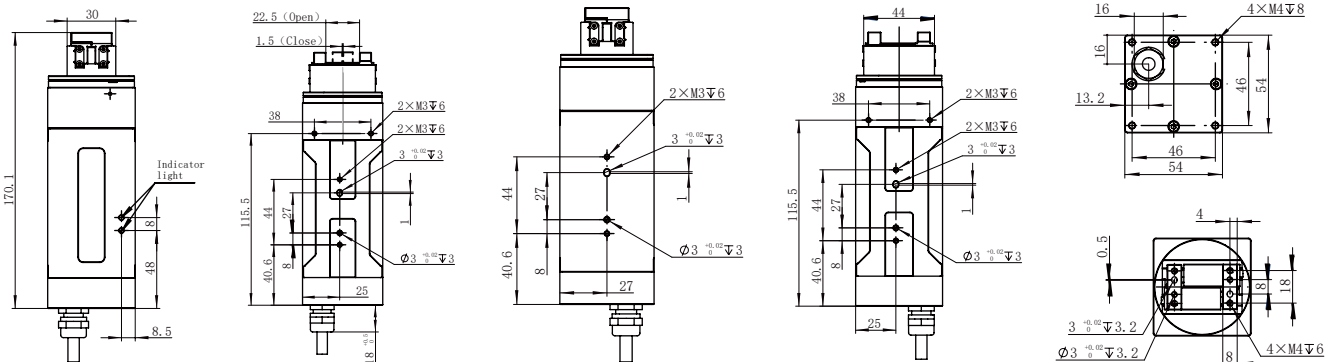

Electric Suction Cup Series

Drive a revolution to replace pneumatic with electric power
Domestically leading small electric suction cup with integrated servo system

Strong suction force, fast suction

Built-in controller, small size, easy to integrate

No need for air source, low maintenance cost

Multiple control methods, easy to operate

Compatible with different numbers and sizes of suction cups

Intelligent detection of suction and release, safe and reliable

Model definition

Z-ESC-70ALL-1-LMC-FXXX-01

ESC	70	ALL	1	LMC	FXXX-01
ESC: Electric suction cup	Specification: 70: width is 70	Communication method: ALL: 485 communication + I/O	Number of suction cups 1: 1 4: 4	Cable outlet method LMC: Nut side outlet	F: Customization option, if it is a standard product, it is blank. XXX: Customer number 01: Version number

Application scenarios

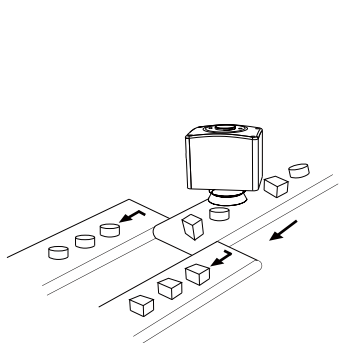

Disorderly placement, sorting and selection of parts

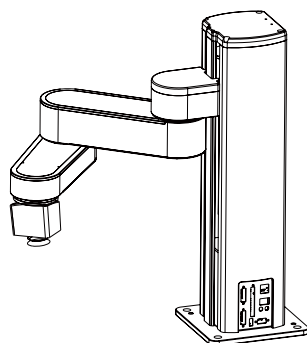

No need for air source

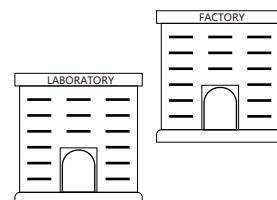

Applications in medical, new retail, 3C industries, etc.

Z-ESC-70



Features

- Compatible with different numbers and sizes of suction cups
- No need for air source, long life
- Release and detection of suction
- Built-in controller: small space occupation, easy integration
- Control method: 485 (Modbus RTU), I/O

Specifications

Item	Parameters
Maximum vacuum degree	50%
Suction	10-50N
Flow rate	1.5L/min
Recommended suction weight*	≤1kg
Suction/release time	0.5S/0.3S
Number of suction cups	1-4
Weight	0.35kg
Dimensions	70*52*74.5mm
Working voltage	24V±10%
Rated current	0.3A
Peak current	0.6A
Power	10W
Protection level	IP40
Noise	60dB (A)
Motor type	Servo motor
Temperature range	5-55°C
Humidity range	35-80%RH (Non-condensing)
Outlet specification	8 core cable,length 2m

*Note: Recommended suction weight is affected by the number and model of suction cups.

Range of motion and dimension

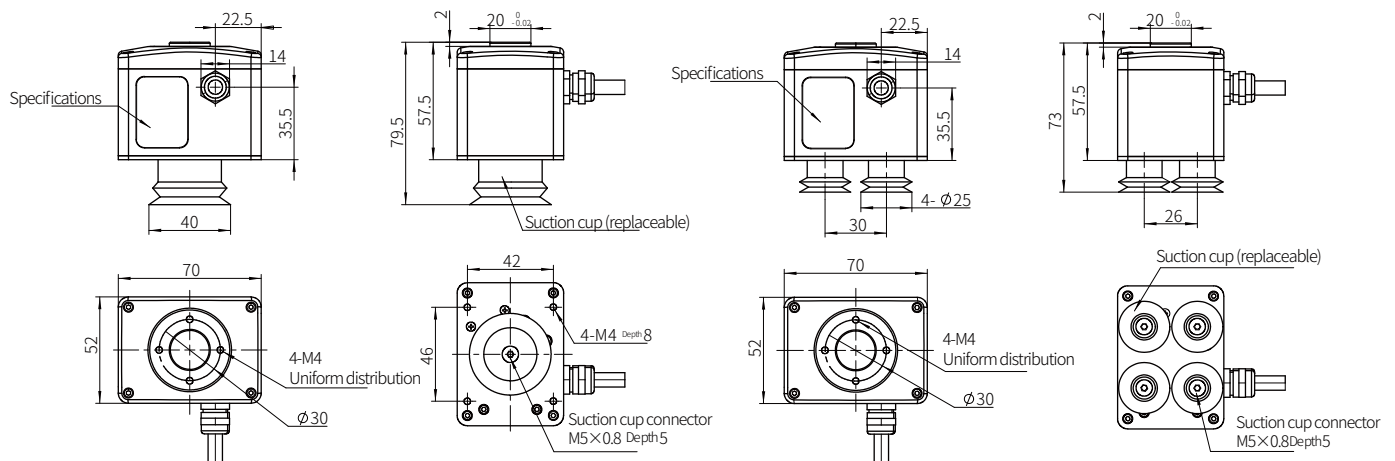

Voice Coil Actuator Series

Choosing our voice coil actuator means choosing the strong support of cutting-edge technology, which injects a smart "core" into your product and allows us to join hands in the new era of future technology!

High speed and high precision, meeting the requirements of high speed and precision pick and place

Long service life, millions of cycle

Hollow shaft design, supports built-in air tube

Two axis integrated, Z axis linear and rotary movements

Soft loading, protect objects intelligently

Built-in spring in Z axis to prevent it from falling off when power off

Model definition

Z-Mod-LRA-25-25-M1-ALL-100-FXXX-1L

LRA	25	25	M1	ALL	100	FXXX-1L
LRA: Linear Rotary Actuators	Thickness: 20: 20mm Frame 25: 25mmFrame 30: 30mmFrame	Journey: 20: 20mm Journey 25: 25mm Journey 30: 30mm Journey	Encoder: M1: Magnetic coding 1μm	Communication method: ALL: I/O+485 bus+pulse	Length of built-in cable: 100mm	F: Non-standard customization options, if it is a standard product, it will be empty XXX: Customer number SS: Customized output shaft CC: Custom cables ST: Custom surface treatment NS: Without protection spring 1L: Additional cable length 0.5m 2L: Additional cable length 1m 3L: Additional cable length 1.5m 4L: Additional wiring length 2m (Incremental in 0.5m units, the maximum length is no more than 10L, i.e. 5m)

Application scenarios

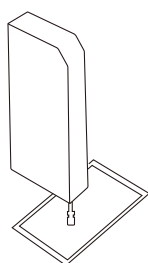

Chip Attach



High-speed and high-precision pick and place

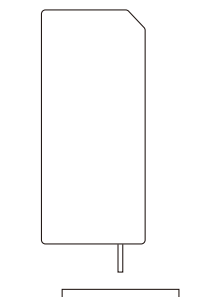

Workpiece inspection

Linear Rotary Actuators Z-Mod-LRA-25-25

Features



- Micron-level travel resolution, repeatability, and force control accuracy of $\pm 3g$
- Drive external and small footprint, light and easy to use, adjustable parameters, slider structure, high precision and speed
- High-speed and high-frequency, precision components can realize 100 million cycles, beyond the traditional motion module.
- Force, position, and speed can be precisely controlled via Modbus
- Control method: 485 (Modbus RTU), I/O, pulse

Specifications

Item	Parameters
Stroke	25mm
No-load frequency	30Hz
Continuous thrust	8N
Peak thrust	12N
Linear travel resolution	0.001mm
Repeatability	$\pm 0.005mm$
Force control accuracy	$\pm 3g$
Rotation repeatability	$\pm 0.02^\circ$
Maximum rotation torque	0.072N·m
Maximum rotation speed	2000RPM
Total weight	1kg
Dimensions	180*100*25mm
Control method	I/O control, pulse control, 485 bus control, EtherCat, CAN
Applicable controller	Z-Mod-DCIC-4
Operating voltage	DC24V $\pm 10\%$
Rated current	(Straight line)1.2A, (Rotation)1A
Peak current	(Straight line)2.2A, (Rotation)2.5A
Protection level	IP40
Use environment	0-40°C, below 85% RH (no frost)

Torque direction

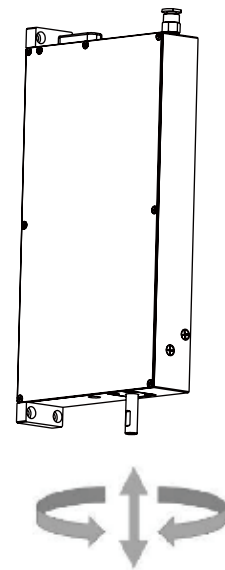

Range of motion and dimension

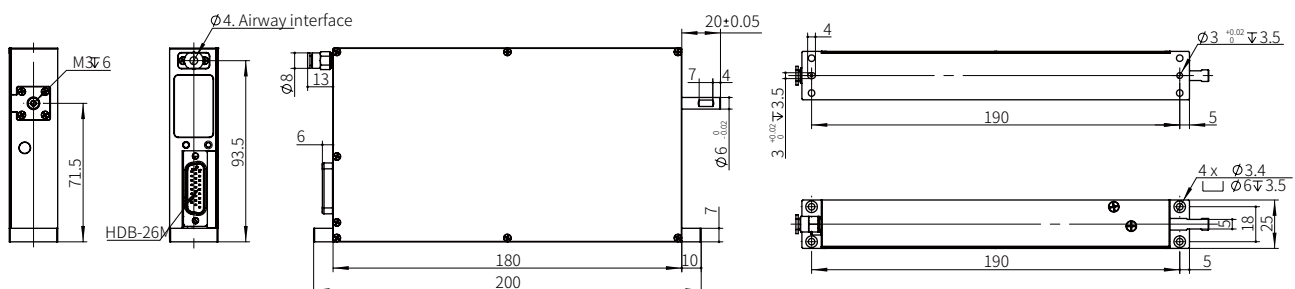

Linear Rotary Actuators Z-Mod-LRA-30-50-M1

Features



- Micron-level travel resolution, repeatability, and force control accuracy of $\pm 3\mu\text{m}$
- Drive external and small footprint, light and easy to use, adjustable parameters, slider structure, high precision and speed
- High-speed and high-frequency, precision components can realize 100 million cycles, beyond the traditional motion module.
- Force, position, and speed can be precisely controlled via Modbus
- Control method: 485 (Modbus RTU), I/O

Specifications

Item	Parameters
Total Stroke	50mm (Adjustable)
Thrust	10N(Adjustable)
Repeatability	$\pm 0.02\text{mm}$
Linear weight	$\leq 200\text{g}$
Transmission mode	Ball spline lead screw
Grease supply	Every 6 months or 1 million movement
Minium moving time	0.35s
Maxium torque	0.05N · m
Maxium speed	2000RPM
Rotation range	Infinite rotation
Weight	650g
Dimension	175*95*30mm
Working voltage	DC24V $\pm 10\%$
Rated current	2A
Peak current	4A
Power	50W
Protection level	IP40
Motor type	Servo motor
Temperature range	5~55°C
Humidity range	35-80% RH (no frost)
Outlet specification	12 core cable, 2 m

Torque direction

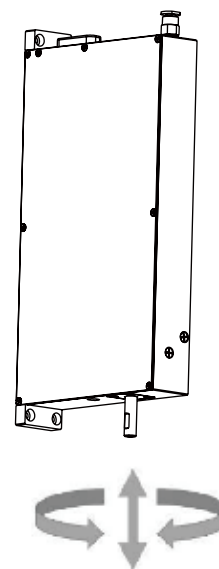

Range of motion and dimension

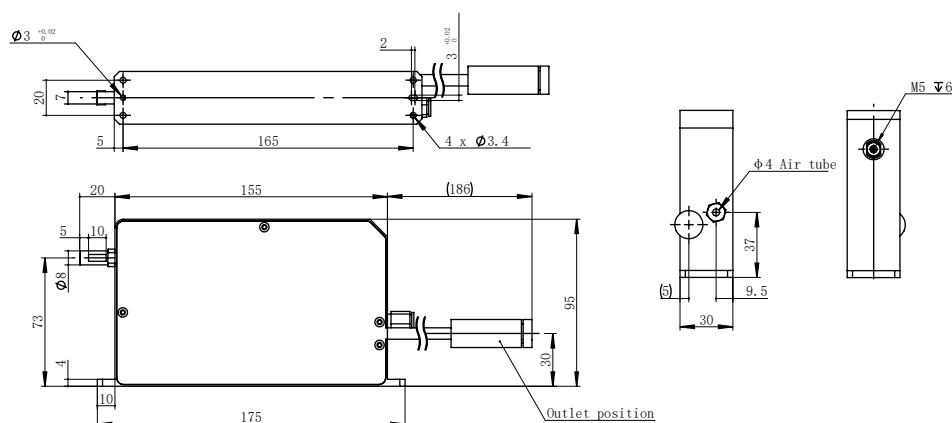

Intelligent Electric Actuator Series

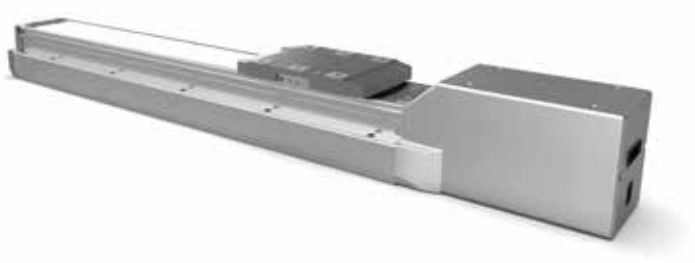

- Innovative craftsmanship

- Simplicity in beauty

- Lightweight and convenient

- Customizable applications

Highly integrated system

- Innovative design that eliminates the need for sensors, while integrating the motor.
- Controller within the module for optimal use of space and stroke.

Easy-to-use software

- No need to build a motion platform, as Z-Arm series control software enables user-friendly operation.
- The simplified programming environment allows even inexperienced users to work collaboratively

Simplified but not simple

- Servo series: no external sensors required

Cost-effective

- Z-Mod offers industrial-grade performance at an affordable price, with more personalized services.

Unique collaborative features

- Higher placement accuracy can be achieved by adjusting parts and aligning them, making the operation more reliable.
- Torque/motion modes can be performed simultaneously without resetting.
- The push mode can detect the pushed object height, making Z-Mod's performance even more intelligent

Intelligent electric cylinder series

Specifications



Item	SE Series electric cylinder																	
	Z-Mod-SE-44		Z-Mod-SE-54			Z-Mod-SE-73			Z-Mod-SE-82			Z-Mod-SE-102			Z-Mod-SE-120			
Motor power /voltage	100W/DC24V		100W/DC24V			200W/DC24V			200W/DC24V			400W/DC48V			400W/DC48V			
Rated torque	0.32N·m		0.32N·m			0.64N·m			0.64N·m			1.27N·m			1.27N·m			
Travel range	50~500mm (50mm interval)		50~500mm (50mm interval)			50~1100mm (50mm interval)			50~1100mm (50mm interval)			50~1250mm (50mm interval)			50~1250mm (50mm interval)			
Ball screw lead	5mm	10mm	5mm	10mm	20mm	5mm	10mm	20mm	5mm	10mm	20mm	5mm	10mm	20mm	5mm	10mm	20mm	32mm
Rated acceleration	0.3G	0.3G	0.3G	0.3G	0.3G	0.3G	0.3G	0.3G	0.3G	0.3G	0.3G	0.3G	0.3G	0.3G	0.3G	0.3G	0.3G	0.3G
Maximum load capacity Horizontal/ wall mounted	30kg	15kg	30kg	15kg	10kg	50kg	30kg	12kg	50kg	30kg	12kg	90kg	70kg	35kg	90kg	70kg	35kg	26kg
vertical	10kg	5kg	10kg	5kg	2.5kg	15kg	8kg	2.5kg	15kg	8kg	2.5kg	36kg	22kg	11kg	36kg	22kg	11kg	8kg
Rated thrust	361.7N	180.9N	361.7N	180.9N	90.5N	723.5N	361.7N	180.9N	723.5N	361.7N	180.9N	1436.3N	718.2N	359.1N	1436.3N	718.2N	359.1N	224.4N
Motor rated speed	3000RPM		3000RPM			3000RPM			3000RPM			3000RPM			3000RPM			
Repeatability	±0.01mm		±0.01mm			±0.01mm			±0.01mm			±0.01mm			±0.01mm			
Drive mode	Ball screw Φ10mm Transformed to C7 grade		Ball screw Φ12mm Transformed to C7 grade			Ball screw Φ16mm Transformed to C7 grade			Ball screw Φ16mm Transformed to C7 grade			Ball screw Φ16mm Transformed to C7 grade			Ball screw Φ16mm Transformed to C7 grade			
Load allowable extension length	200mm the following		300mmthe following			300mm the following			300mm the following			500mm the following			500mm the following			
Sensor cable length	2m		2m			2m			2m			2m			2m			



Item	KK Series				Item	Electric putter	
	Z-Mod-KK-60-10SE		Z-Mod-KK-86-20SE			Z-Mod-EPA-35-50	
Motor power /voltage	100W/DC24V		200W/DC24V		stroke	50mm	
Rated torque	0.32N·m		0.64N·m		Lead	1mm	2mm
Travel range	58mm108-508mm (100mm interval)		210-610mm (100mm interval) 810mm		Maximum speed	50mm/s	100mm/s
Ball screw lead	5mm	10mm	10mm	20mm	Maximum continuous push force	200N	100N
Rated acceleration	0.3G	0.3G	0.3G	0.3G	Maximum load mass	horizontal: 6kg vertical: 1.5kg	horizontal: 3kg vertical: 1.5kg
Maximum load capacity Horizontal/ wall mounted	20kg	10kg	30kg	15kg	Repeatability	±0.02mm	
vertical	8kg	4kg	12kg	6kg	Push rod does not rotate. Accuracy	±1.5°	
Rated thrust	361.7N	180.9N	361.7N	180.9N	Allowable torque at the end of the push rod	MR:3.14N·m; MP: 1.42N·m MY: 1.42N·m	
Motor rated speed	3000RPM		3000RPM		Operating Voltage	DC24V±10%	
Repeatability	±0.02mm		±0.025mm		Rated current	2A	
Drive mode	Ball screw Φ12mm Transformed to C7 grade		Ball screw Φ12mm Transformed to C7 grade		Peak current	6A	
Load allowable extension length	/		/		Protection level	IP40	
Sensor cable length	2m		2m				



Item	Micro slide		Item	Rotating push rod	
	Z-Mod-MS-80-50			Z-Mod-RP-80	
stroke	50mm		stroke	1315°/s	
Lead	1mm	2mm	Lead	1.7N·m	
Maximum speed	50mm/s	100mm/s	Maximum speed	3kg·cm ²	
Maximum continuous push force	200N		Maximum continuous push force	±0.02°	
Maximum load mass	horizontal: 1.2kg vertical: 0.5kg	horizontal : 6kg vertical: 0.5kg	Maximum load mass	±0.02°	
Repeatability	±0.02mm		Repeatability	5kg	
Push rod does not rotate. Accuracy	MR: 46.8N·m; MP: 25.6N·m; MY: 25.6N·m		Push rod does not rotate. Accuracy	4.5N·m	
Allowable torque at the end of the push rod	I/O control, 485 bus control, Pulse control (pulse + direction)		Allowable torque at the end of the push rod	I/O control, 485 bus control, Pulse control (pulse + direction)	
Operating Voltage	DC24V±10%		Operating Voltage	DC24V±10%	
Rated current	2A		Rated current	2A	
Peak current	6A		Peak current	6A	
Protection level	IP40		Protection level	IP40	

Z-Mod-SE Intelligent Electric Actuator(Servo series)



Z-Mod-SE-44



Z-Mod-SE-54



Z-Mod-SE-73



Z-Mod-SE-82



Z-Mod-SE-102



Z-Mod-SE-120

Features

- Intelligent motion control software with PIO positioning mode, pulse mode, and torque mode
- Built-in absolute encoder, no need for external sensors
- Integrates servo and control systems internally
- Full dustproof steel belt
- Embedded guide rail structure
- External oil injection design

Model definition

Z-Mod-SE-82ZS-20SE-10-200-C7-S1-N1-DV-N-FXXX-01

SE	82	ZS	20SE	10	200
SE: Slide series SEC: EtherCAT communication function version	44: Slide width 44mm 54: Slide width 54mm 73: Slide width 73mm 82: Slide width 82mm 102: Slide width 102mm 120: Slide width 120mm	Z: Direct connection R: Right side L: Left side B: Backward side S: Built-in driver Without S: External driver	10SE: 100W Servo 20SE: 200W Servo 40SE: 400W Servo	5: Lead 5 10: Lead 10 20: Lead 20	200: Stroke 200mm 1000: Stroke 1000mm
C7	S1	N1	DV	N	FXXX-01
Screw precision level C7	S: No external sensor base S1: 1PCS (External sensor base) S2: 2PCS (External sensor base) S3: 3PCS (External sensor base)	N: No proximity switch N1: NPN 1 pcs Proximity switch N2: NPN 2 pcs Proximity switch N3: NPN 3 pcs Proximity switch P1: PNP 1 pcs Proximity switch P2: PNP 2 pcs Proximity switch P3: PNP 3 pcs Proximity switch	DV: Full dustproof steel belt	N: Without brake B: With brake	F: Customization option, if it is a standard product, it is blank XXX: Customer number 01: Version number

Z-Mod-SE-44-10SE

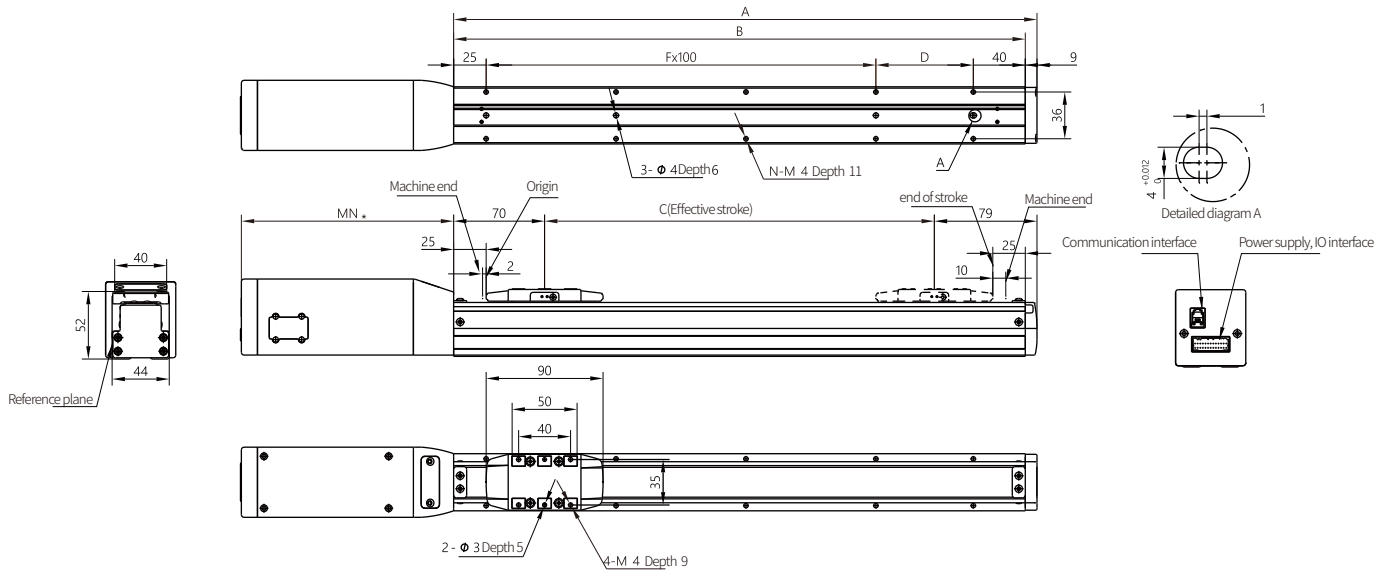

Note: MN=164 (without brake), MN=184 (with brake)

There are also left turn electric actuator, for detailed specifications, please refer to the electric actuator product manual.

Specifications

Model performance	
Motor power/voltage	100W/DC24V
Rated torque	0.32N·m
Ball screw lead	5mm / 10mm
Maximum speed	250mm/s / 500mm/s
Rated acceleration (Note 1)	0.3G / 0.3G
Maximum payload capacity horizontal/wall-mounted	30kg / 15kg
Vertical Mount	10kg / 5kg
Rated thrust	361.7N / 180.9N
Stroke range	50-500mm (50mm Interval)
Motor rated speed	3000RPM

Note 1: 1G=9800mm/sec².

General specification	
Repeatability	±0.01mm
Driving mode	Ball screw Φ10mm converted to C7 grade
Dynamic allowable torque (Note 2)	Ma: 8.7N·m; Mb: 8.7N·m; Mc: 12.5N·m
Load allowed extension length	Below 200mm
Sensor	①-LS; ②-HOME; ③+LS, NPN, DC24V
Sensor cable length	2m
Base material	Extruded aluminum material, white luster
Installation area accuracy requirement	Flatness below 0.05mm
Working environment	0-40°C, 85%RH (non-condensing)

Note 2: The value when the mileage is 10000 kilometers

Sensor wiring diagram

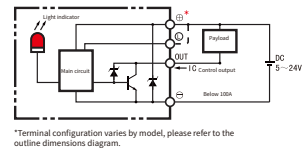

*Terminal configuration varies by model, please refer to the outline dimensions diagram.

Torque Definition

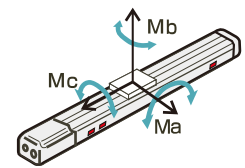

Dimensional diagram code explanation · quality

Unit:mm

Effective payload	50	100	150	200	250	300	350	400	450	500
A	199	249	299	349	399	449	499	549	599	649
B	190	240	290	340	390	440	490	540	590	640
C	50	100	150	200	250	300	350	400	450	500
D	25	75	25	75	25	75	25	75	25	75
F	1	1	2	2	3	3	4	4	5	5
N	6	6	8	8	10	10	12	12	14	14
Quality (kg)	1.3	1.5	1.7	1.9	2.1	2.3	2.5	2.7	2.9	3.1

Z-Mod-SE-54-10SE

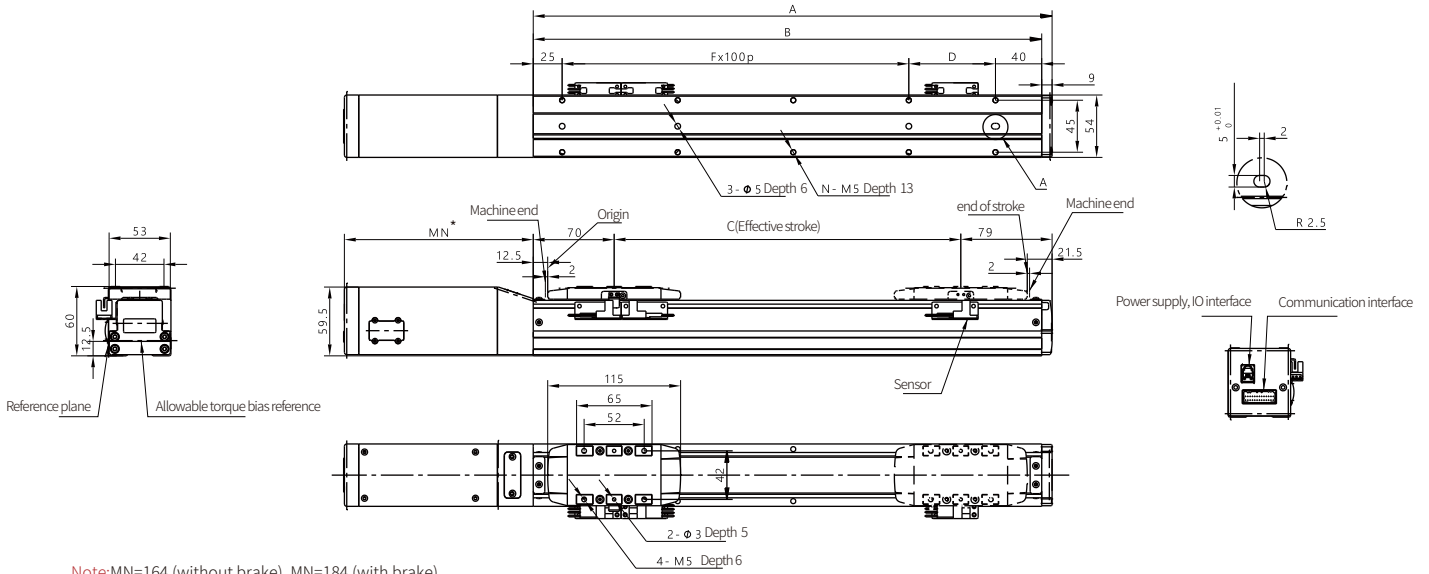

Note: MN=164 (without brake), MN=184 (with brake)

There are also left-turn, right-turn, and back-turn types of electric actuators, for detailed specifications, please refer to the electric actuator product manual.

Specifications

Model performance			
Motor power/voltage	100W/DC24V		
Rated torque	0.32N·m		
Ball screw lead	5mm	10mm	20mm
Maximum speed	250mm/s	500mm/s	1000mm/s
Rated acceleration (Note 1)	0.3G	0.3G	0.3G
Maximum payload capacity horizontal/wall-mounted	30kg	15kg	10kg
Vertical Mount	10kg	5kg	2.5kg
Rated thrust	361.7N	180.9N	90.5N
Stroke range	50-500mm (50mm Interval)		
Motor rated speed	3000RPM		

Note 1: 1G=9800mm/sec².

Model performance	
Repeatability	±0.01mm
Driving mode	Ball screw Φ10mm converted to C7 grade
Dynamic allowable torque (Note 2)	Ma: 13.8N·m; Mb: 13.8N·m; Mc: 20.2N·m
Load allowed extension length	Below 300mm
Sensor	①-LS; ②-HOME; ③-LS, NPN, DC24V
Sensor cable length	2m
Base material	Extruded aluminum material, white luster
Installation area accuracy requirement	Flatness below 0.05mm
Working environment	0-40°C, 85%RH (non-condensing)

Note 2: The value when the mileage is 10000 kilometers

Sensor wiring diagram

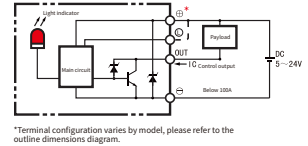

*Terminal configuration varies by model, please refer to the outline dimensions diagram.

Torque Definition

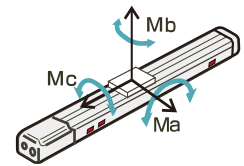

Dimensional diagram code explanation · quality

Unit:mm

Effective payload	50	100	150	200	250	300	350	400	450	500	550	600	650	700	750	800
A	199	249	299	349	399	449	499	549	599	649	699	749	799	849	899	949
B	190	240	290	340	390	440	490	540	590	640	690	740	790	840	890	940
C	50	100	150	200	250	300	350	400	450	500	550	600	650	700	750	800
D	25	75	25	75	25	75	25	75	25	75	25	75	25	75	25	75
F	1	1	2	2	3	3	4	4	5	5	6	6	7	7	8	8
N	6	6	8	8	10	10	12	12	14	14	16	16	18	18	20	20
Quality (kg)	2.1	2.25	2.4	2.55	2.7	2.85	3	3.15	3.3	3.45	3.6	3.75	3.9	4.05	4.2	4.35

Z-Mod-SE-73-20SE

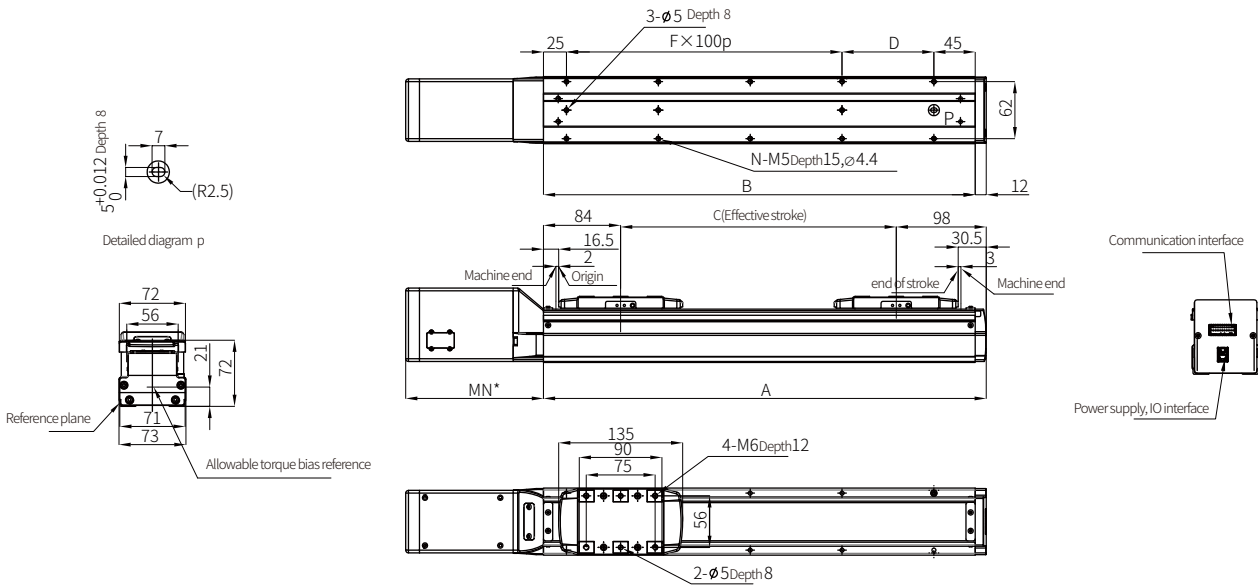

* Note: MN=149 (without brake), MN=184 (with brake),
There is also a left-folding electric cylinder. For detailed parameters, refer to the electric cylinder product manual

Specifications

Model performance			
Motor power/voltage	200W/DC24V		
Rated torque	0.64N·m		
Ball screw lead	5mm	10mm	20mm
Maximum speed	250mm/s	500mm/s	1000mm/s
Rated acceleration (Note 1)	0.3G	0.3G	0.3G
Maximum payload capacity horizontal/wall-mounted	50kg	30kg	12kg
Vertical Mount	15kg	8kg	2.5kg
Rated thrust	723.5N	361.7N	180.9N
Stroke range	50-1100mm (50mm Interval)		
Motor rated speed	3000RPM		

Note 1: 1G=9800mm/sec².

Sensor wiring diagram

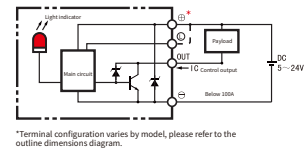

*Terminal configuration varies by model, please refer to the outline dimensions diagram.

Model performance	
Repeatability	±0.01mm
Driving mode	Ball screw Ø16mm converted to C7 grade
Dynamic allowable torque (Note 2)	Ma: 42.1N·m; Mb: 42.1N·m; Mc: 63.2N·m
Load allowed extension length	Below 300mm
Sensor	①-LS; ②-HOME; ③+LS, NPN, DC24V
Sensor cable length	2m
Base material	Extruded aluminum material, white luster
Installation area accuracy requirement	Flatness below 0.05mm
Working environment	0-40°C, 85%RH (non-condensing)

Note 2: The value when the mileage is 10000 kilometers

Torque Definition

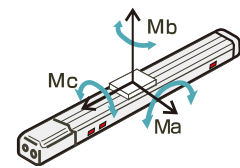

Motor direct mount type

Dimensional diagram code explanation · quality

Unit:mm

Effective payload	50	100	150	200	250	300	350	400	450	500	550	600	650	700	750	800	850	900	950	1000	1050	1100
A	232	282	332	382	432	482	532	582	632	682	732	782	832	882	932	982	1032	1082	1132	1182	1232	1282
B	220	270	320	370	420	470	520	570	620	670	720	770	820	870	920	970	1020	1070	1120	1170	1220	1270
C	50	100	150	200	250	300	350	400	450	500	550	600	650	700	750	800	850	900	950	1000	1050	1100
D	50	100	50	100	50	100	50	100	50	100	50	100	50	100	50	100	50	100	50	100	50	100
F	1	1	2	2	3	3	4	4	5	5	6	6	7	7	8	8	9	9	10	10	11	11
N	6	6	8	8	10	10	12	12	14	14	16	16	18	18	20	20	22	22	24	24	26	26
Quality (kg)	2.5	2.77	3.04	3.31	3.58	3.85	4.12	4.39	4.66	4.93	5.2	5.47	5.74	6.01	6.28	6.55	6.82	7.09	7.36	7.63	7.9	8.17

Z-Mod-SE-82-20SE

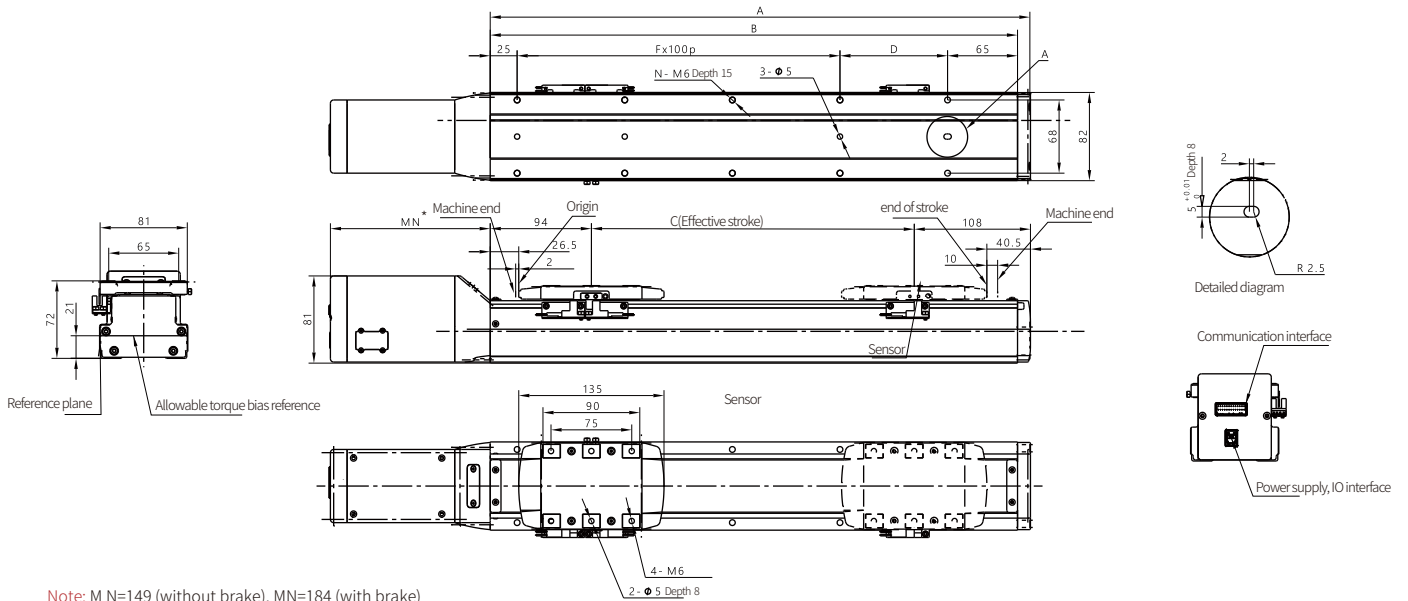

Note: M N=149 (without brake), MN=184 (with brake)

There are also left-turn, right-turn, and back-turn types of electric actuators, for detailed specifications, please refer to the electric actuator product manual.

Specifications

Model performance			
Motor power/voltage	200W/DC24V		
Rated torque	0.64N·m		
Ball screw lead	5mm	10mm	20mm
Maximum speed	250mm/s	500mm/s	1000mm/s
Rated acceleration (Note 1)	0.3G	0.3G	0.3G
Maximum payload capacity horizontal/wall-mounted	50kg	30kg	12kg
Vertical Mount	15kg	8kg	2.5kg
Rated thrust	723.5N	361.7N	180.9N
Stroke range	50-1100mm (50 mmInterval)		
Motor rated speed	3000RPM		

Note1: 1G=9800mm/sec².

Model performance	
Repeatability	±0.01mm
Driving mode	Ball screw Φ16mm converted to C7 grade
Dynamic allowable torque (Note 2)	Ma: 46.7N·m; Mb: 46.7N·m; Mc: 77.8N·m
Load allowed extension length	Below 300mm
Sensor	①-LS; ②-HOME; ③+LS, NPN, DC24V
Sensor cable length	2m
Base material	Extruded aluminum material, white luster
Installation area accuracy requirement	Flatness below 0.05mm
Working environment	0~40°C, 85%RH (non-condensing)

Note 2: The value when the mileage is 10000 kilometers

Sensor wiring diagram

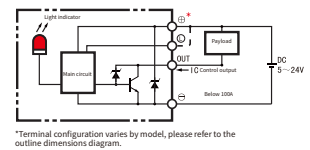

Torque Definition

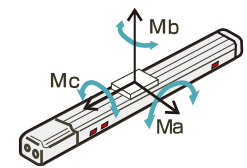

Motor direct mount type

Dimensional diagram code explanation · quality

Unit:mm

Effective payload	50	100	150	200	250	300	350	400	450	500	550	600	650	700	750	800	850	900	950	1000	1050	1100
A	252	302	352	402	452	502	552	602	652	702	752	802	852	902	952	1002	1052	1102	1152	1202	1252	1302
B	240	290	340	390	440	490	540	590	640	690	740	790	840	890	940	990	1040	1090	1140	1190	1240	1290
C	50	100	150	200	250	300	350	400	450	500	550	600	650	700	750	800	850	900	950	1000	1050	1100
D	50	100	50	100	50	100	50	100	50	100	50	100	50	100	50	100	50	100	50	100	50	100
F	1	1	2	2	3	3	4	4	5	5	6	6	7	7	8	8	9	9	10	10	11	11
N	6	6	8	8	10	10	12	12	14	14	16	16	18	18	20	20	22	22	24	24	26	26
Quality (kg)	4.1	4.4	4.7	5	5.3	5.6	5.9	6.2	6.5	6.8	7.1	7.4	7.7	8	8.3	8.6	8.9	9.2	9.5	9.8	10.1	10.4

Z-Mod-SE-102-40SE

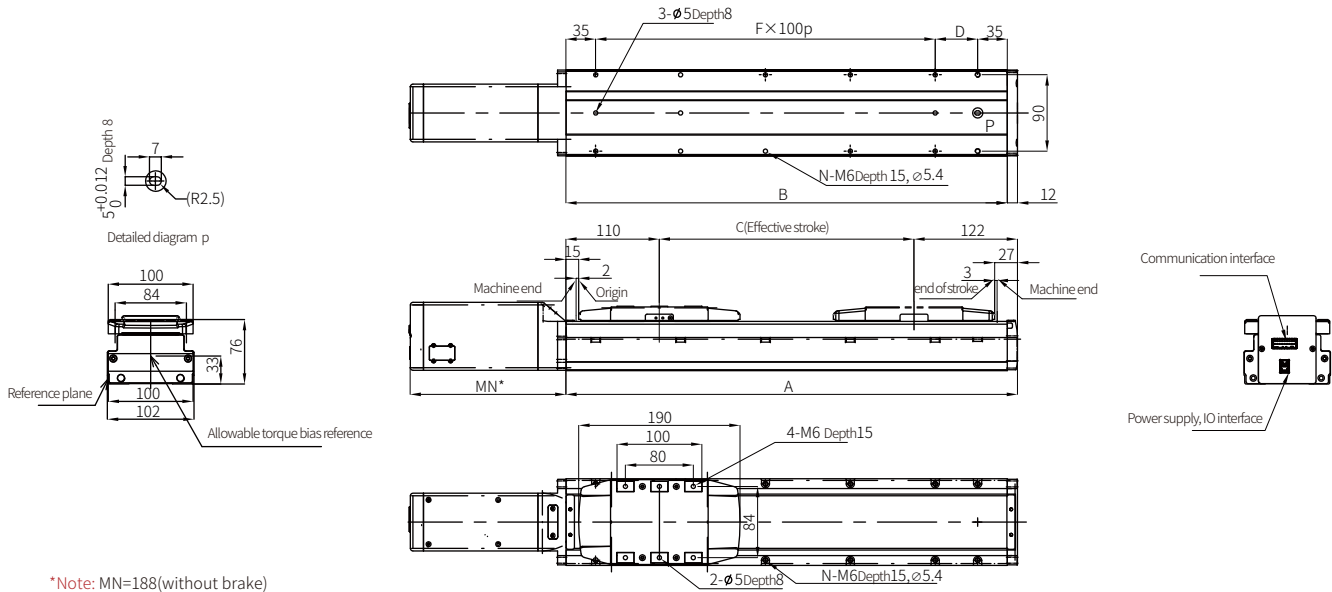

*Note: MN=188(without brake)

There are also left turn electric actuator, for detailed specifications, please refer to the electric actuator product manual.

Specifications

Model performance			
Motor power/voltage	400W/DC48V		
Rated torque	1.27N·m		
Ball screw lead	5mm	10mm	20mm
Maximum speed	250mm/s	500mm/s	1000mm/s
Rated acceleration (Note 1)	0.3G	0.3G	0.3G
Maximum payload capacity horizontal/wall-mounted	90kg	70kg	35kg
Vertical Mount	36kg	22kg	11kg
Rated thrust	1436.3N	718.2N	359.1N
Stroke range	50-1250mm (50mm Interval)		
Motor rated speed	3000RPM		

Note1: 1G=9800mm/sec².

Model performance	
Repeatability	±0.01mm
Driving mode	Ball screw Φ16mm converted to C7 grade
Dynamic allowable torque (Note 2)	Ma: 141N·m; Mb: 141N·m; Mc: 288.3N·m
Load allowed extension length	Below 500mm
Sensor	①-LS; ②-HOME; ③+LS, NPN, DC24V
Sensor cable length	2m
Base material	Extruded aluminum material, white luster
Installation area accuracy requirement	Flatness below 0.05mm
Working environment	0-40°C, 85%RH (non-condensing)

Note 2: The value when the mileage is 10000 kilometers

Sensor wiring diagram

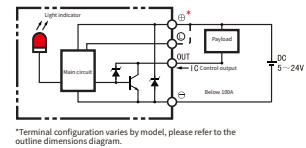

Torque Definition

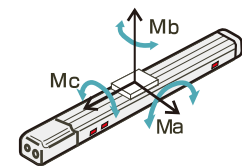

Motor direct mount type

Dimensional diagram code explanation · quality

Unit:mm

Effective payload	50	100	150	200	250	300	350	400	450	500	550	600	650	700	750	800	850	900	950	1000	1050	1100	1150	1200	1250
A	282	332	382	432	482	532	582	632	682	732	782	832	882	932	982	1032	1082	1132	1182	1232	1282	1332	1382	1432	1482
B	270	320	370	420	470	520	570	620	670	720	770	820	870	920	970	1020	1070	1120	1170	1220	1270	1320	1370	1420	1470
C	50	100	150	200	250	300	350	400	450	500	550	600	650	700	750	800	850	900	950	1000	1050	1100	1150	1200	1250
D	50	100	50	100	50	100	50	100	50	100	50	100	50	100	50	100	50	100	50	100	50	100	50	100	50
F	1	2	2	3	3	4	4	5	5	6	6	7	7	8	8	9	9	10	10	11	11	12	12	13	13
N	6	8	8	10	10	12	12	14	14	16	16	18	18	20	20	22	22	24	24	26	26	28	28	30	30
Quality (kg)	4.5	4.9	5.4	5.9	6.3	6.8	7.3	7.7	8.2	8.7	9.2	9.6	10	10.6	11	11.5	12	12.4	12.9	13.4	13.9	14.3	14.8	15.3	15.7

Z-Mod-SE-120-40SE

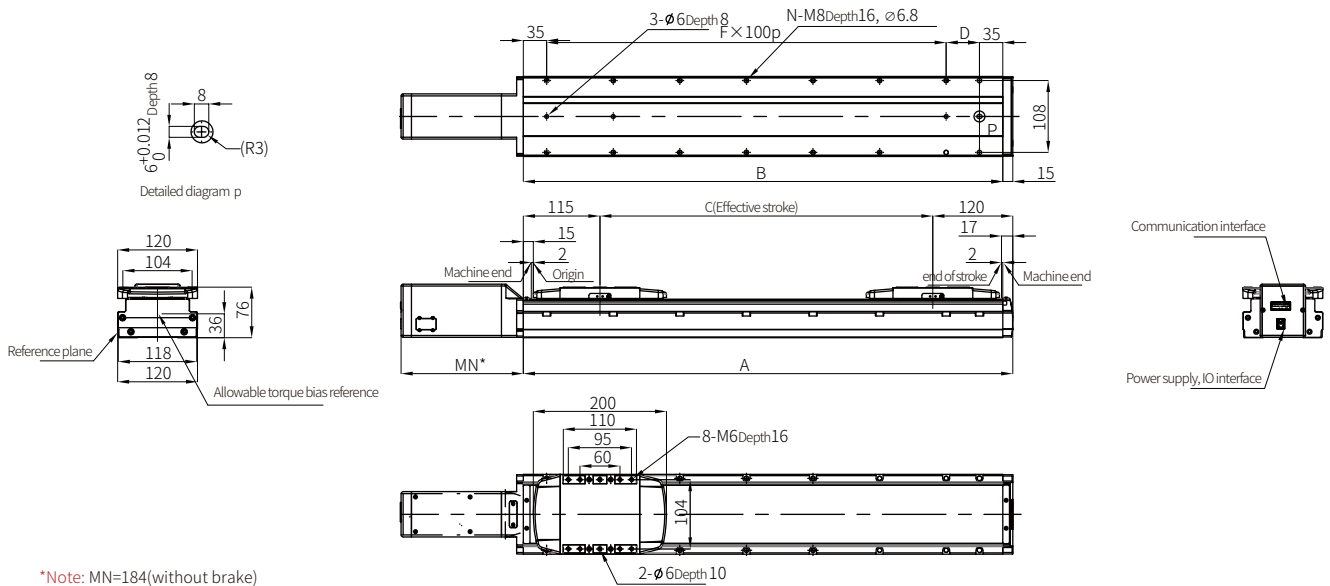

*Note: MN=184(without brake)

There are also left turn electric actuator, for detailed specifications, please refer to the electric actuator product manual.

Specifications

Model performance			
Motor power/voltage	400W/DC48V		
Rated torque	1.27N·m		
Ball screw lead	5mm	10mm	20mm
Maximum speed	250mm/s	500mm/s	1000mm/s
Rated acceleration (Note 1)	0.3G	0.3G	0.3G
Maximum payload capacity horizontal/wall-mounted	90kg	70kg	35kg
Vertical Mount	36kg	22kg	11kg
Rated thrust	1436.3N	718.2N	359.1N
Stroke range	50-1250mm (50mm Interval)		
Motor rated speed	3000RPM		

Note1: 1G=9800mm/sec².

Model performance	
Repeatability	±0.01mm
Driving mode	Ball screw Φ16mm converted to C7 grade
Dynamic allowable torque (Note 2)	Ma: 116.4N·m; Mb: 116.4N·m; Mc: 209.5N·m
Load allowed extension length	Below 500mm
Sensor	①-LS; ②-HOME; ③+LS, NPN, DC24V
Sensor cable length	2m
Base material	Extruded aluminum material, white luster
Installation area accuracy requirement	Flatness below 0.05mm
Working environment	0~40°C, 85%RH (non-condensing)

Note 2: The value when the mileage is 10000 kilometers

Sensor wiring diagram

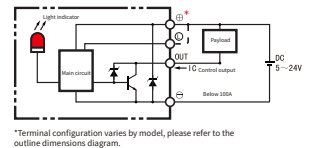

Torque Definition

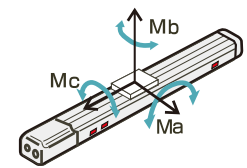

Motor direct mount type

Dimensional diagram code explanation · quality

Unit:mm

Effective payload	50	100	150	200	250	300	350	400	450	500	550	600	650	700	750	800	850	900	950	1000	1050	1100	1150	1200	1250
A	285	335	385	435	485	535	585	635	685	735	785	835	885	935	985	1035	1085	1135	1185	1235	1285	1335	1385	1435	1485
B	270	320	370	420	470	520	570	620	670	720	770	820	870	920	970	1120	1070	1120	1170	1220	1270	1320	1370	1420	1470
C	50	100	150	200	250	300	350	400	450	500	550	600	650	700	750	800	850	900	950	1000	1050	1100	1150	1200	1250
D	100	50	100	50	100	50	100	50	100	50	100	50	100	50	100	50	100	50	100	50	100	50	100	50	100
F	1	2	2	3	3	4	4	5	5	6	6		7	8	8	9	9	10	10	11	11	12	12	13	13
N	6	8	8	10	10	12	12	14	14	16	16	18	18	20	20	22	22	24	24	26	26	28	28	30	30
Quality (kg)	5.5	6	6.6	7.1	7.6	8.2	8.7	9.2	9.8	10.3	10.8	11.3	11.9	12.4	12.9	13.5	14	14.5	15.1	15.6	16.1	16.6	17.1	18	18.5

Z-Mod-KK Electric Actuator (KK series)



Z-Mod-KK-60



Z-Mod-KK-86

Features

- Intelligent motion control software with PIO positioning mode, pulse mode, and torque mode
- Built-in absolute encoder, no need for external sensors
- Integrates servo and control systems internally
- Modular design, block-style combination
- U-shaped steel base rail, high strength, high payload-bearing
- Four-sided equal load

Model definition

Z-Mod-KK-60ZS-10SE-10-200-C7-S1-N1-DP-N-FXXX-01

KK	60	ZS	10SE	10	200
KK: KK series	60: Steel rail width 60mm 86: Steel rail width 86mm	Z: Direct connection S: Built-in driver Without S: external drive	10SE: 100W Servo 20SE: 200W Servo	5: Lead 5 10: Lead 10 20: Lead 20	200: Rail length 200mm 540: Rail length 540mm
C7	S1	N1	DV	N	FXXX-01
Screw precision level C7	S: No external sensor base S1: 1PCS (External sensor base) S2: 2PCS (External sensor base) S3: 3PCS (External sensor base)	N: No proximity switch N1: NPN 1 pcs Proximity switch N2: NPN 2 pcs Proximity switch N3: NPN 3 pcs Proximity switch P1: PNP 1 pcs Proximity switch P2: PNP 2 pcs Proximity switch P3: PNP 3 pcs Proximity switch	NP: No cover DP: aluminum cover DT: telescopic cover	N: without brake B: with brake	F: Customization option, if it's a standard product, it is blank. XXX: Customer number 01: version number

Z-Mod-KK-60-10SE

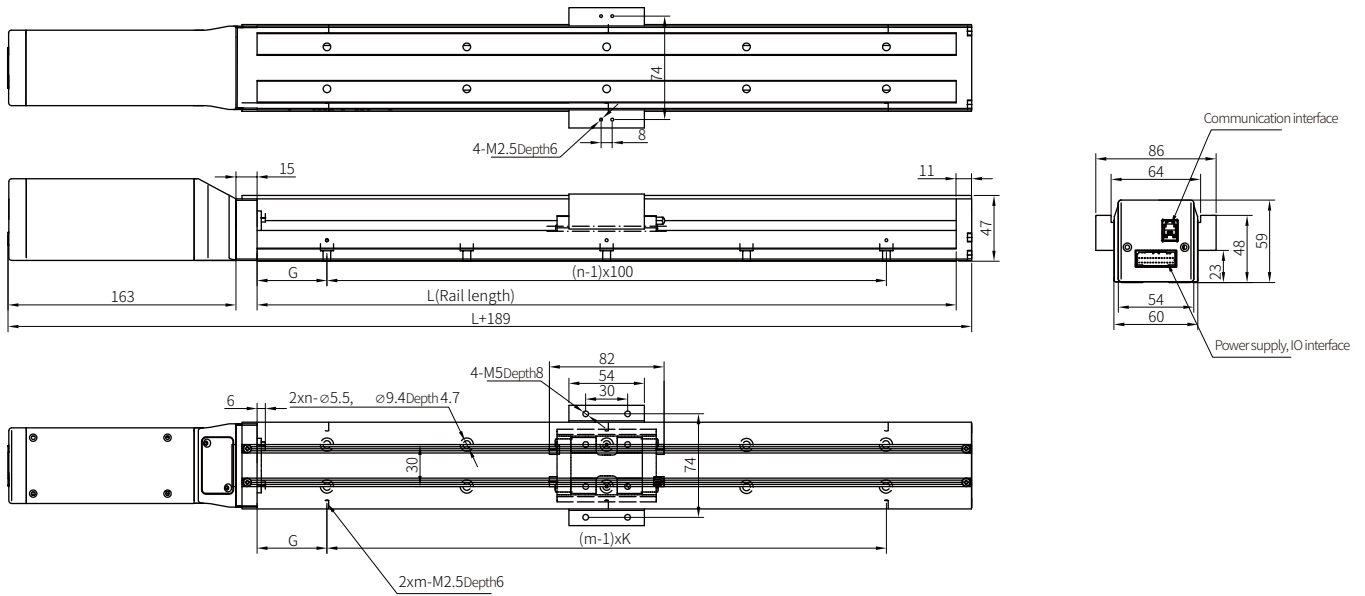

Specifications

Model performance	
Motor power/voltage	100W/DC24V
Rated torque	0.32N·m
Ball screw lead	5mm / 10mm
Maximum speed	250mm/s / 500mm/s
Rated acceleration (Note 1)	0.3G / 0.3G
Maximum payload capacity horizontal/wall-mounted	20kg / 10kg
Vertical Mount	8kg / 4kg
Rated thrust	361.7N / 180.9N
Stroke range	58mm 108-508mm (100mm Interval)
Motor rated speed	3000RPM

Note1: 1G=9800mm/sec².

Model performance	
Repeatability	±0.02mm
Driving mode	Ball screw Φ12mm converted to C7 grade
Dynamic allowable torque (Note 2)	Ma: 152N·m; Mb: 152N·m; Mc: 419N·m
Load allowed extension length	/
Sensor	①-LS; ②-HOME; ③+LS, NPN, DC24V
Sensor cable length	2m
Base material	Cast steel, Black
Installation area accuracy requirement	Flatness below 0.05mm
Working environment	0-40°C, 85%RH (non-condensing)

Note 2: The value when the mileage is 10000 kilometers

Sensor wiring diagram

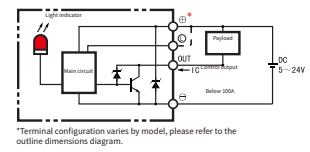

Torque Definition

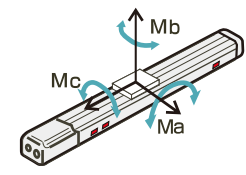

Dimensional diagram code explanation · quality

Unit:mm

Rail lengthL	150	200	300	400	500	600
Maximum stroke	58	108	208	308	408	508
G	25	50	50	50	50	50
M	2	2	2	4	3	6
N	2	2	3	4	5	6
K	100	100	200	100	200	100
Quality (kg)	2.55	2.95	3.55	4.15	4.75	5.45

Z-Mod-KK-86-20SE

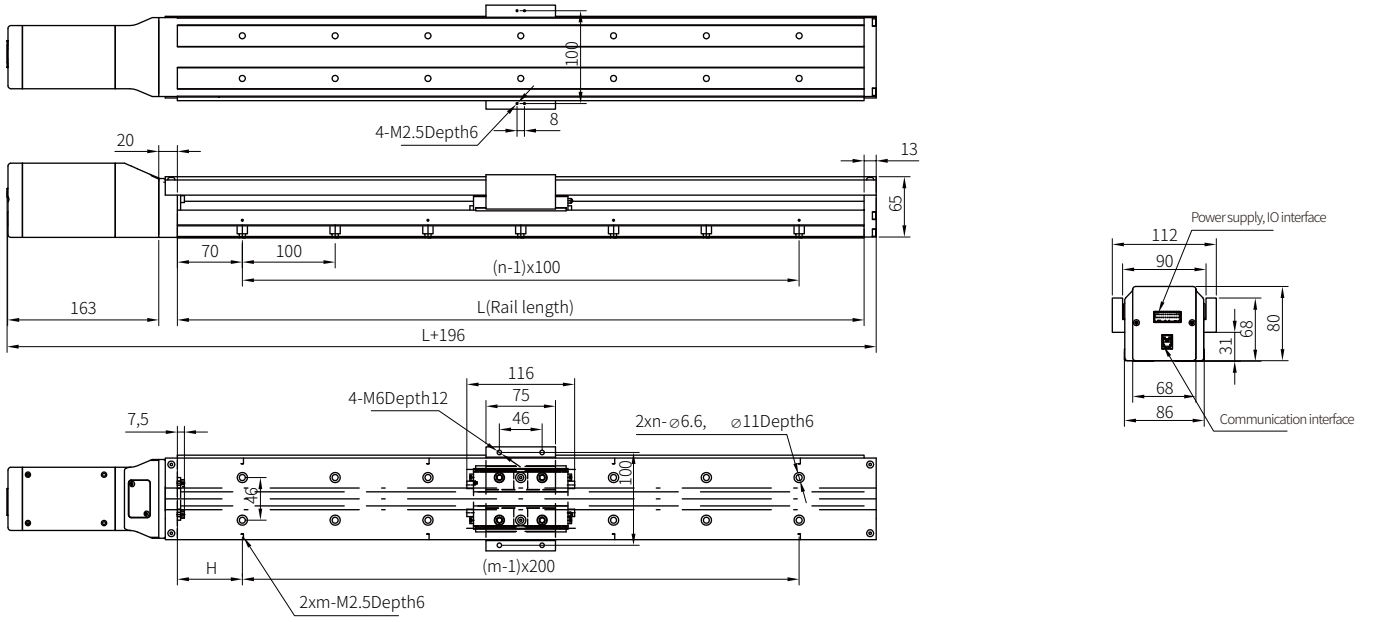

Specifications

Model performance	
Motor power/voltage	200W/DC24V
Rated torque	0.64N·m
Ball screw lead	10mm / 20mm
Maximum speed	500mm/s / 1000mm/s
Rated acceleration (Note 1)	0.3G / 0.3G
Maximum payload capacity horizontal/wall-mounted	30kg / 15kg
Vertical Mount	12kg / 6kg
Rated thrust	361.7N / 180.9N
Stroke range	210-610mm (100mm Interval) 810mm
Motor rated speed	3000RPM

Sensor wiring diagram

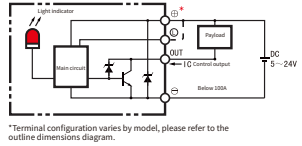

Model performance	
Repeatability	±0.025mm
Driving mode	Ball screw Φ15mm converted to C7 grade
Dynamic allowable torque (Note 2)	Ma: 622N·m; Mb: 622N·m; Mc: 1507N·m
Load allowed extension length	/
Sensor	①-LS; ②-HOME; ③+LS, NPN, DC24V
Sensor cable length	2m
Base material	Cast steel, Black
Installation area accuracy requirement	Flatness below 0.05mm
Working environment	0~40°C, 85%RH (non-condensing)

Torque Definition

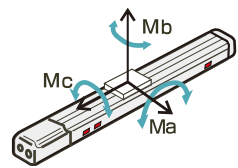

Dimensional diagram code explanation · quality

Unit:mm

Code	340	440	540	640	740	940
Rail lengthL	340	440	540	640	740	940
Maximum stroke	210	310	410	510	610	810
H	70	20	70	20	70	70
M	2	3	3	4	4	5
N	3	4	5	6	7	9
Quality (kg)	7.85	9.15	10.35	11.65	12.95	14.35

Definition of Mini Electric Actuator Models

Z-Mod-MS-80-50-010-ALL-100-FXXX-1L

MS	80	50	010	ALL	100	FXXX-1L
MS: Mini Slide Actuator	Size Code: 80: 80mm frame	Stroke: 50: 50mm Stroke	Lead: 010: 1mm Lead 020: 2mm Lead	Cable outlet method: ALL: I/O+485 bus	Built-in cable length: 100mm	F: F: Customization option, if it's a standard product, it is blank. XXX: Customer number 1L: Additional wire length of 0.5m 2L: Additional wire length of 1m 3L: Additional wire length of 1.5m 4L: Additional wire length of 2m (Increments in units of 0.5m, maximum not exceeding 10L, i.e. 5m)

Z-Mod-EP-35ZS-50-010-ALL-100-FXXX-1L

EP	35ZS	50	010	ALL	100	FXXX-1L
EP: Electric Linear Actuator	Size Code: 35ZS: 35mm direct connection 35RS: 35mm foldback 42ZS: 42mm direct connection 42RS: 42mm foldback	Stroke: 50: 50mm Stroke 100: 100mm Stroke	Lead: 010: 1mm Lead 020: 2mm Lead	Cable outlet method: ALL: I/O+485 bus	Built-in cable length: 100mm	F: F: Customization option, if it's a standard product, it is blank. XXX: Customer number 1L: Additional wire length of 0.5m 2L: Additional wire length of 1m 3L: Additional wire length of 1.5m 4L: Additional wire length of 2m (Increments in units of 0.5m, maximum not exceeding 10L, i.e. 5m)

Z-Mod-EPA-35-50-010-ALL-100-FXXX-1L

EPA	35	50	010	ALL	100	FXXX-1L
EPA: Electric Platform Linear Actuator	Size Code: 35: 35mm frame	Stroke: 50: 50mm Stroke 100: 100mm Stroke	Lead: 010: 1mm Lead 020: 2mm Lead	Cable outlet method: ALL: I/O+485 bus	Built-in cable length: 100mm	F: F: Customization option, if it's a standard product, it is blank. XXX: Customer number 1L: Additional wire length of 0.5m 2L: Additional wire length of 1m 3L: Additional wire length of 1.5m 4L: Additional wire length of 2m (Increments in units of 0.5m, maximum not exceeding 10L, i.e. 5m)

Z-Mod-RP-80-13-ALL-100-FXXX-1L

RP	80	13	ALL	100	FXXX-1L
RP: Rotary Actuator	Size Code: 80: 80mm frame	Reduction ratio: 13: 13.68 Compare	Cable outlet method: ALL: I/O+485 bus	Built-in cable length: 100mm	F: F: Customization option, if it's a standard product, it is blank. XXX: Customer number 1L: Additional wire length of 0.5m 2L: Additional wire length of 1m 3L: Additional wire length of 1.5m 4L: Additional wire length of 2m (Increments in units of 0.5m, maximum not exceeding 10L, i.e. 5m)

Z-Mod-LRA-25-25-M1-ALL-100-FXXX-1L

LRA	25	25	M1	ALL	100	FXXX-1L
LRA: Linear Rotary Actuator	Thickness: 20: 20mm frame 25: 25mm frame 30: 30mm frame	journey: 20: 20mm journey 25: 25mm journey 30: 30mm journey	Encoder: M1: Magnetic 1µm	Cable lead-out method: ALL: I/O+485bus+pulse	Built-in cable length: 100mm	F: F: Customization option, if it's a standard product, it is blank. XXX: Customer number SS: Custom output shaft CC: Custom cable ST: Custom surface treatment NS: Without protective spring 1L: Additional wire length of 0.5m 2L: Additional wire length of 1m 3L: Additional wire length of 1.5m 4L: Additional wire length of 2m (Increments in units of 0.5m, maximum not exceeding 10L, i.e. 5m)

Electric platform actuator Z-Mod-EPA-35-50

Features



- Small size, large thrust, high precision, and high cost performance
- Using slider structure, strong anti-overturning force
- Force, position, and speed can be accurately controlled through Modbus
- Long service life: millions of cycles, better than cylinders
- Control method: 485, I/O, pulse

Specifications

Item	Parameters	
Stroke	50mm	
Lead	1mm	2mm
Maximum speed	50mm/s	100mm/s
Max continuous thrust	200N	100N
Max payload	Horizontal: 6kg/Vertical: 2kg	Horizontal: 3kg / Vertical: 1kg
Repeatability	±0.02mm	
Force control accuracy	±10%	
Non-rotating accuracy	±1.5°	
Allowable torque at the end of actuator	MR:3.14N·m; MP:1.42N·m; MY:1.42N·m	
Weight	0.6kg	
Dimensions	125*48*35mm	
Control method	I/O control, 485 bus control, pulse control (pulse + direction)	
Applicable controller	Z-Mod-DCIC-4	
Working voltage	DC24V±10%	
Rated current	2A	
Peak current	6A	
Protection level	IP40	
Working environment	0~40°C, 85%RH (non-condensing)	
Outlet specification	Cable 2m, minimum bending radius>70mm	

Torque direction

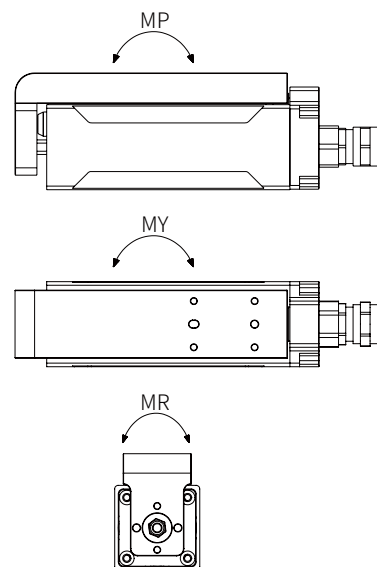

Range of motion and dimension

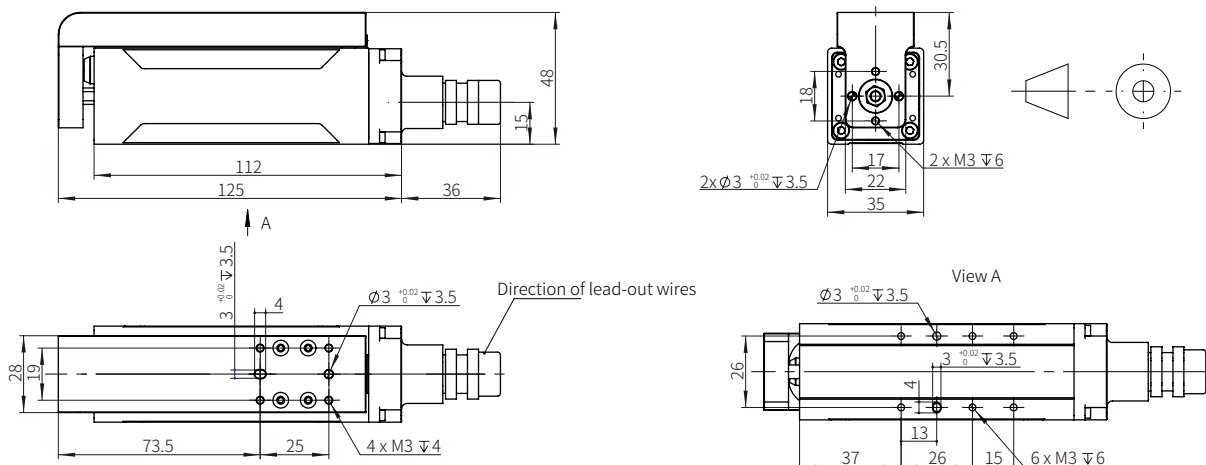

Rotary push rod Z-Mod-RP-80

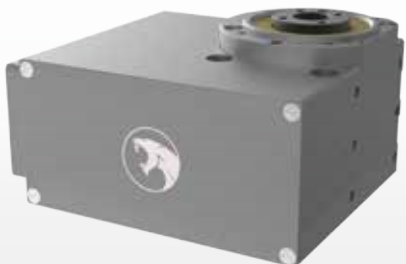

Features

- Small size, large torque, high precision, zero backlash, high cost performance
- Built-in driver, small footprint, easy to operate, fast response
- Force, position, and speed can be accurately controlled through Modbus
- Long service life: millions of cycles, better than cylinders
- Control method: 485, I/O, pulse

Specifications

Item	Parameters
Maximum speed	1315°/s
Maximum torque	1.7N·m
Allowable moment of inertia	3kg·cm ²
Repeatability	±0.02°
Return to origin accuracy	±0.02°
Allowable axial load	5kg
Allowable payload torque	4.5N·m
Weight	0.9kg
Dimensions	102*80*55mm
Control method	I/O control, 485 bus control, pulse control (pulse + direction)
Working voltage	DC24V±10%
Rated current	2A
Peak current	6A
Protection level	IP40
Working environment	0-40°C, 85%RH (non-condensing)
Outlet specification	Cable 2m, minimum bending radius>70mm

Torque direction

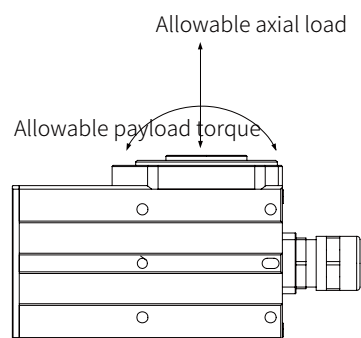

Range of motion and dimension

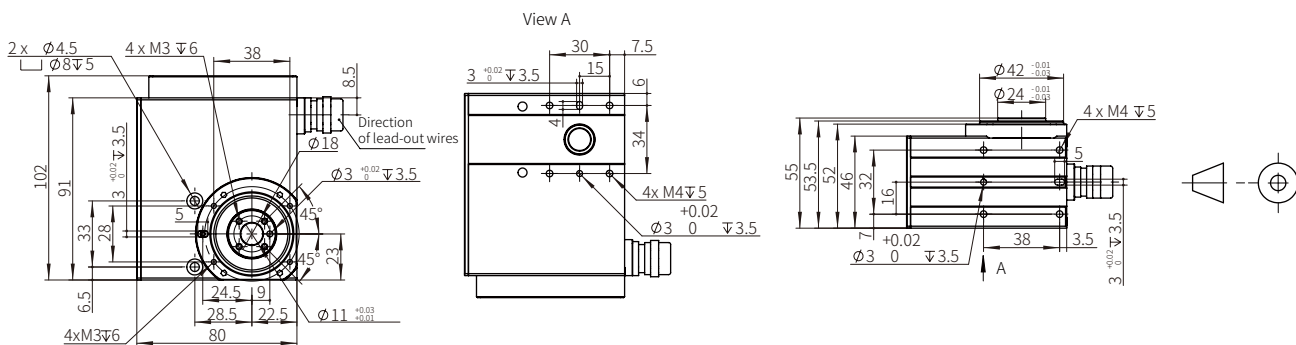

Driver Z-Mod-DCIC-4



Features

- Dual axis driver
- Self-tuning and easy to operate
- Compatible with servo motor and voice coil motor
- Force, position, and speed can be accurately controlled through Modbus
- Control method: 485, I/O, pulse

Specifications

Item	Parameters
Axis control number	Dual axis
Power supply voltage	DC24V±10%
Rated current	4A per axis
Control method	Control method: 485, I/O, pulse, Ethercat, CAN
I/O interface	Opto-isolated, 8 inputs + 8 outputs
Max input pulse frequency	40KPPS
Max cable length	5m
Weight	0.4kg
Dimensions	175*83*28.5mm
Protection level	IP20
Working environment	0~40°C, 85%RH (non-condensing)

Port diagram

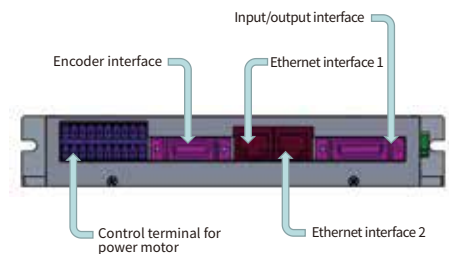
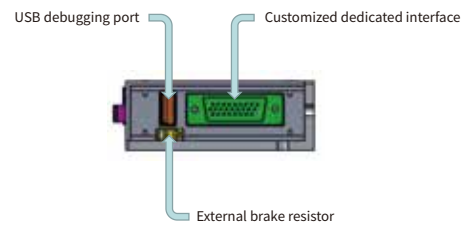

Range of motion and dimension

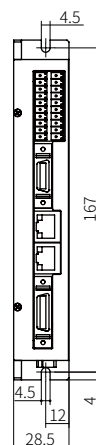
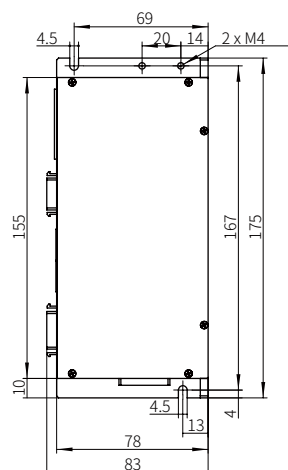

Software introduction

HitBotDrive Upper Machine Interface Instruction

- ①Port setting: The serial port and baud rate setting of the electric cylinder connected to the host computer. Select different serial ports and baud rates according to the different parameters of the electric cylinder, and then re-search.
- ②Linear setting: The basic operation interface of the linear part of the electric cylinder, including the control display of parameters such as position, speed, current and acceleration. The feedback of the top status bar is the status feedback of the linear part of the electric cylinder. When the user uses the host computer to operate the electric cylinder, the state of the linear part of the electric cylinder can be judged according to the status feedback.
- ③Rotation setting: The basic operation interface of the rotation part of the electric cylinder, including the control display of parameters such as rotation angle (absolute angle), relative rotation angle, speed, current and acceleration. The feedback of the top status bar is the status feedback of the rotation part of the electric cylinder. When the user uses the host computer to operate the electric cylinder, the state of the linear part of the electric cylinder can be judged according to the status feedback. , the current state of the rotating part of the electric cylinder can be judged based on the status feedback.
- ④ Public area: This area can check whether the electric cylinder is offline and whether the initialization is successful; it can control the electric cylinder to perform manual initialization, status refresh, reset the rotation value of multiple turns, write the setting parameters to the device, restore the factory setting parameters, etc. After the writing is successful, the host computer pops up a window to prompt that the writing is successful, and the power is turned off and restarted to take effect.
- ⑤ Slave list: This area feeds back the connected model and the picture of the model, where 30-50 is the model number and 1 is the ID number of the model.
- ⑥ Parameter setting description: This area displays various parameter settings of the electric cylinder, such as point information, IO mode, ID, baud rate and other parameter settings, as shown in Figure 8.8 (a), 8.8 (b), 8.8 (c)



Features of ISM series drive-control-in-one servo motors

Network control

Through various communication networks, operation data and parameter settings, as well as input and operation of operation instructions, can flexibly correspond to the network used by users and shorten the design time

EtherCat Bus Control

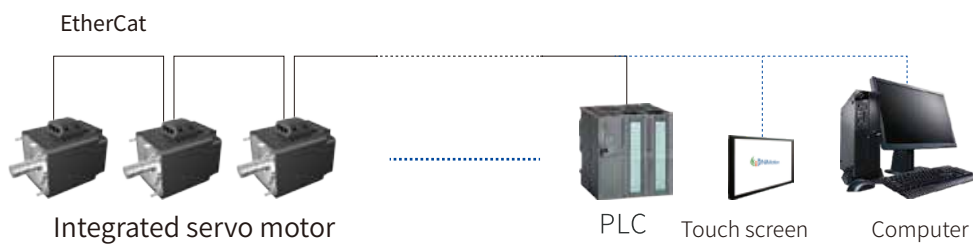

· EtherCat communication is stable and reliable, with a maximum communication rate of 100MHz

· Support multi-axis synchronization function

· Support EtherCat Cia402 protocol

· Support user-defined protocol

I/O control

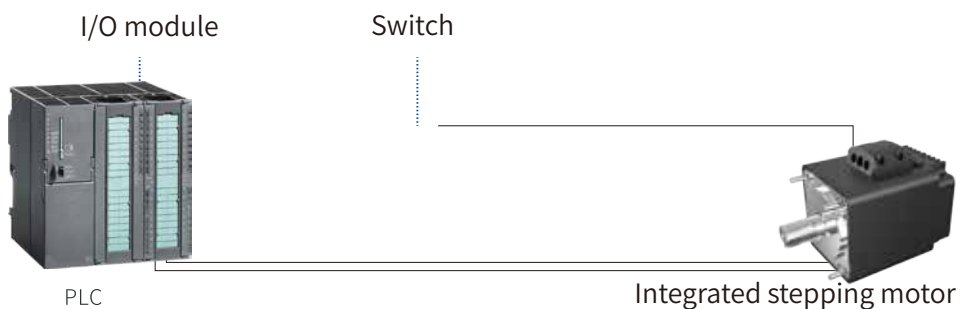

· Use switches and PLC I/O modules to directly control the start and stop of the motor without having to worry about communication protocols.

· Without the need of communication module, making control simpler

Support online upgrading and multi-platform development

- Convenient maintenance, development according to user needs, online upgrade without returning to the factory
- Provide multiple platform development cases, making any control so simple
- Support LabVIEW, C++ and other secondary development



Simple design

- Only 2cm is added on the basis of the standard motor shape
- Integrated simple design, compact structure, high efficiency, small size
- Save installation space
- Integrate multiple protection devices, safe and reliable

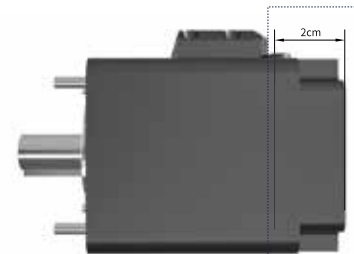

Closed-loop/ open-loop control

- Adopt closed-loop control mode, maintain stable position after positioning, no oscillation
- Low-speed silent control, low vibration
- Support stall detection
- Support overheating protection

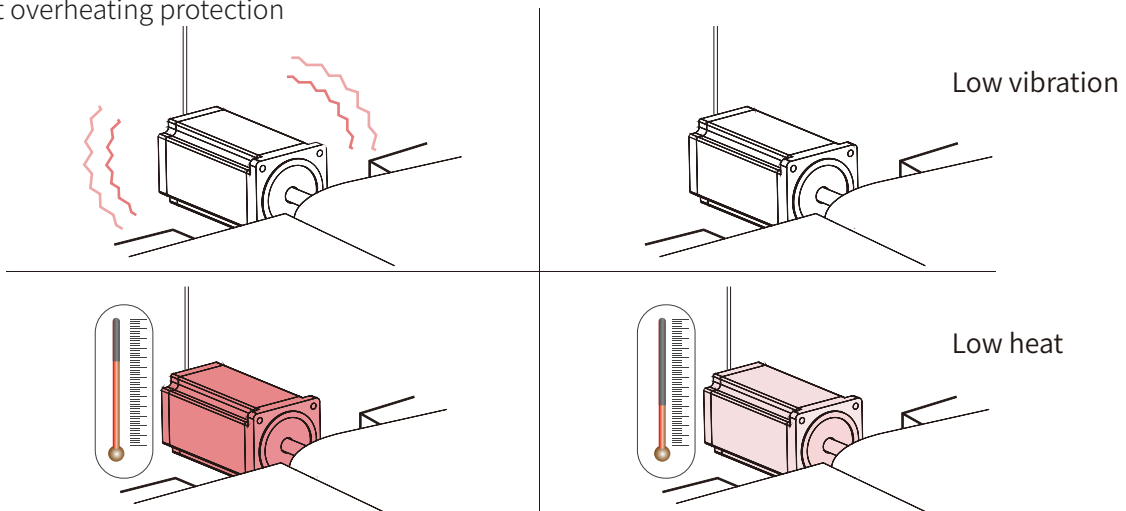

Integrate driver and controller

- The integrated driver supports a maximum current of 10A and natural cooling
- Open parameters are available for user debugging
- Supports soft limit function
- Supports position mode, speed mode, and origin return mode

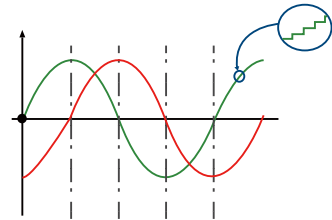

Features of ISM series drive-integrated servo motors

Integrated high-precision encoder

- Internally integrated high-resolution absolute encoder
- The current absolute position is known upon power-on
- The prohibited entry range can be flexibly set to avoid the restricted area when returning to zero, making control simpler

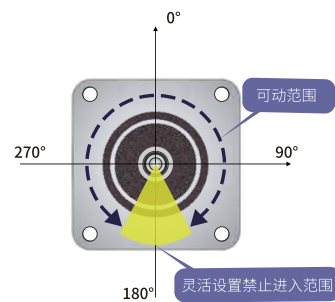

Efficient origin return and setting

- No origin sensor is required, and the origin return is completed at high speed
- Save wiring and can be used in places where sensors cannot be installed
- Can be manually moved to any position and set as the origin
- Supports stalled origin return
- Integrates multiple origin return algorithms and can be flexibly configured

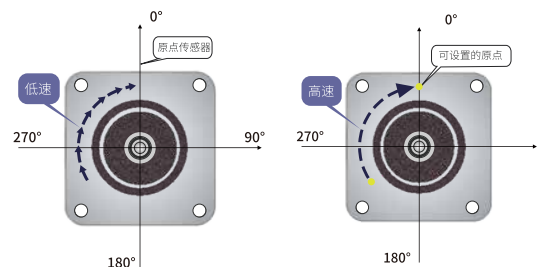

Product Specifications



	Z-Mod-ISM20M-ECT	Z-Mod-ISM20M-ECT-B	Z-Mod-ISM40M-ECT	Z-Mod-ISM40M-ECT-B
Rated voltage	DC 48V	DC 48V	DC 48V	DC 48V
Rated power	200	200	400	400
Rated speed	3000	3000	3000	3000
Rated torque	0.64	0.64	1.27	1.27
Rated current	8	8	13	13
Number of pole pairs	5	5	5	5
Encoder	17bit Multi-turn absolute magnetic encoder	17bit Multi-turn absolute magnetic encoder	17bit Multi-turn absolute magnetic encoder	17bit Multi-turn absolute magnetic encoder
Brake	not have	have	not have	have
Appearance	Half-wrapped type	Half-wrapped type	Half-wrapped type	Half-wrapped type
Dimension (excluding protrusions and shafts)	60×72×84.5	60×72×110.5	60×72×110.5	60×72×139.5
With mounting screws or not	no	no	no	no
Communication method	ethercat	ethercat	ethercat	ethercat

Product accessories

Motor cable (extension cable)

Name	Specifications	
Network cable		
Motor connecting cable		
Brake resistor assembly (optional)		
Brake resistor assembly	Model: AG-ISM-B	Note: One power supply must be purchased with a brake resistor assembly

*Note: All accessories in this page is not included in the motors, and need to be separately purchased !

Accessory Package

Definition of accessories

AH-Z42E30-FSW-FXXX-01

AH	Z42E30	F	S	W	FXXX-01
<p>AH: Hardware gripper accessories (such as clamp fingers/adaptor flanges, etc.)</p> <p>AE: Electrical wiring accessories</p> <p>AS: Standard parts, such as couplings, timing belts, etc.</p> <p>AFA: Fifth-axis components</p> <p>AG: Comprehensive accessories</p> <p>AD: WIFI wireless network module, Modbus, optocoupler isolation</p>	<p>Z42E30: Z-Arm XX42(E) and Z-EFG-30 Related accessories</p> <p>Z42E20: Z-Arm XX42(E) and Z-EFG-20 Related accessories</p> <p>Z42E8S: Z-Arm XX42(E) and Z-EFG-8S Related accessories</p> <p>Z42E50: Z-Arm XX42(E) and Z-EFG-50 Related accessories</p> <p>Z42ER20: Z-Arm XX42(E) and Z-ERG-20 Related accessories</p> <p>Z32E20: Z-Arm XX32 and Z-EFG-20 Related accessories</p> <p>Z32E8S: Z-Arm XX32 and Z-EFG-8S Related accessories</p> <p>Z50E20: Z-Arm XX50 and Z-EFG-20 Related accessories</p> <p>Z50E30: Z-Arm XX50 and Z-EFG-30 Related accessories</p> <p>Z50E50: Z-Arm XX50 and Z-EFG-50 Related accessories</p> <p>Z50ER20: Z-Arm XX50 and Z-ERG-20 Related accessories</p> <p>Z60E20: Z-Arm XX60 and Z-EFG-20 Related accessories</p> <p>Z60E30: Z-Arm XX60 and Z-EFG-30 Related accessories</p> <p>Z60E50: Z-Arm XX60 and Z-EFG-50 Related accessories</p> <p>Z60ER20: Z-Arm XX60 and Z-ERG-20 Related accessories</p> <p>Z42: Only accessories for Z-Arm XX42(E)</p> <p>E30: Only accessories for Z-EFG-30</p> <p>Z22: Only accessories for Z-Arm 1522</p> <p>.....and so on</p>	<p>F: Flange connecting the manipulator arm to the electric gripper</p> <p>DK: Cable connecting the manipulator arm to the electric gripper</p> <p>J: Standard clamp finger for electric gripper</p> <p>3D: 3D printing accessories</p> <p>LA: Laser engraving accessories</p> <p>MF: One pair of male and female heads</p> <p>M: Only female head</p> <p>MF/DB15/DB9: One pair of male and female DB15 and DB9 heads each</p> <p>M/DB15: One female DB15 head</p> <p>F3.57: One KF2EDGKM-3.5-7pin plug</p>	<p>C: Vertical installation of electric gripper</p> <p>S: Horizontal installation of electric gripper</p>	<p>Blank: Electric gripper installation without housing</p> <p>W: Electric gripper installation with housing</p>	<p>F: Customization option, if it is a standard product, it is blank</p> <p>XXX: Customer number</p> <p>01: Version number</p>

For example:

AH-Z42E50-FC: represents the flange for vertical installation of Z-Arm XX42(E) and Z-EFG-50, without housing

AH-Z42E30-FSW: represents the flange with housing for horizontal installation of Z-Arm XX42(E) and Z-EFG-30

AE-Z42E30-DK: represents the control cable between Z-Arm XX42(E) and Z-EFG-30

AH-E30-J: represents the standard clamp finger for Z-EFG-30

AE-Z42-XX: represents some electrical related accessories inside the Z-Arm XX42(E) manipulator arm

For models that cannot be reflected, please contact sales to add...

Accessory Kit List

Sort	Appellation	Gripper Finger Application/Type	Applicable gripper	Rendering	
Finger clamp	AH-E12-J	Clamp finger closed to the end	EFG-12		
	AH-E20-J	Clamp finger closed to the end	EFG-20		
	AH-E20-J1	The clamp finger does not close completely	EFG-20		
	AH-ER20-J	Special for twisting test tube	ERG-20C		
Sort	Appellation	Gripper direction	Applicable gripper	Applicable Robot Arm	Rendering
Flange	AH-Z32E20-FC	Vertical + Horizontal	EFG-8S, EFG-12, EFG-20	XX32	
	AH-Z42E20-FS	Level	EFG-8S, EFG-12, EFG-20	XX42, XX50, XX60	
	AH-Z42E20-FC	Vertical	EFG-8S, EFG-12, EFG-20	XX42, XX50, XX60	

Accessory Kit List

Sort	Appellation	Gripper direction	Applicable gripper	Applicable Robot Arm	Rendering
Flange	AH-Z42E26-FS	Vertical + Horizontal	EFG-26, EFG-26P	XX42, XX50, XX60	
	AH-Z42E50-FC	Vertical	EFG-50, EFG-30	XX42, XX50, XX60	
	AH-Z42E50-FS	Level	EFG-50, EFG-30	XX42, XX50, XX60	
	AH-Z42E50-FSW	Level	EFG-50-LMH	XX42, XX50, XX60	
	AH-Z42ER20-FS	Level	ERG-20	XX42, XX50, XX60	
	AH-Z42ER20-FC	Vertical	ERG-20	XX42, XX50, XX60	
	AH-Z42ES70-FC	Vertical	ESC-70	XX42, XX50, XX60	
	AH-ZSES70-FC	Vertical	ESC-70	S622, S922, S1400	
Sort	Appellation	Gripper installation direction	Applicable gripper	Applicable Robot Arm	Rendering
Flange + Clamp	AH-Z42E08S-FSW	Level	EFG-8S	XX42, XX50, XX60	
	AH-Z42E20-FSW	Level	EFG-20	XX42, XX50, XX60	
Wiring kit					
AE-Z42-MF/DB15/DB9+F3.57			AE-Z32-MF/DB15+F3.57		
DB9 One male and one female lead wire DB15 One male and one female lead wire			KF2EDGKM-3.5-7pin One plug DB15 One male and one female lead wire		
Sort	Appellation	length	Applicable gripper		
Cables	8 Core extension cord	2m	Z-EFG-20PALL-CG-8F, Z-EFG-20FALL-LMC-8F, Z-EFG-26ALL-LMC-8F, Z-EFG-26PALL-LMC-8F, Z-ESC-70ALL-1-LM-8F		
	12 Core extension cord	2m	Z-EFG-30ALL-LMC-12F, Z-EFG-50ALL-LMC-12F, Z-EFG-40-100-12F, Z-EFG-60-150-12F, Z-EFG-80-200-12F, Z-Mod-EP series, Z-Mod-MS-80-50-12F, Z-Mod-RP-80-12F		
	ERG-20 Extension cord	2m	Z-ERG-20CALL-LMC-12F, Z-ERG-20-100ALL-LMC-12F		
Sort	Appellation	Specification			
	Electric cylinder USB to 485 Connector	Z-Mod/USB to 485/cable length 500mm/number of ports 1			

Example: If you order AH-Z42E50-FC or AH-Z50/Z60E50-FC, you only need to order AH-Z42E30-FC; if you order AH-Z50/Z60E20-FS, you only need to order AH-Z42E20-FS, and so on.

Remark: For all models with 8F or 12F suffixes, the cable length is about 15cm and an extension cable is required.

Machining Introduction



Help customers solve six major pain points

▶ **Few items, no one picks up**

We effectively reduce machining costs and improve production efficiency by strengthening technical support and innovating cooperation models, and can meet customers' needs for small batch orders.

▶ **No one followed up**

We have established an effective follow-up mechanism and designated a dedicated person to track the order throughout the entire process, ensuring that customers can understand the production status of the workpiece in a timely manner and deal with any problems that may arise in a timely manner.

▶ **Costs are too high**

We effectively reduce machining costs through reasonable cost control and resource integration.

▶ **No quality assurance**

We have established a strict quality management system to comprehensively monitor the procurement of raw materials, processing, and finished product inspection.

▶ **Delivery time is too long**

We strengthen the management of production plans and progress, rationally arrange the production resources and time of each process, and ensure the smooth progress of the processing.

▶ **After-sales service is not perfect**

In order to solve the pain points of imperfect product after-sales, we have established a complete after-sales service system to provide professional technical support and maintenance services.

Integrated Processing

Committed to establishing a benchmark for China's machinery processing industry.

Advanced equipment

Unified management and more thoughtful service
 Prototype making, drop shipping, mass production, and comprehensive service
 Real-time follow-up and transparent process to let you fully understand the production progress and feel secure



The company has advanced machining equipment, including CNC lathes, CNC milling machines, grinders, drilling machines, etc. These equipment are high-end models of well-known domestic and foreign brands, with the characteristics of high precision and high efficiency.



The CNC lathe is one of the company's main equipment. It adopts a high-rigidity structure and is equipped with a high-performance spindle and feed system, which can achieve high-speed cutting and precise processing. The CNC milling machine has high dynamic performance and a large worktable area, which is suitable for the processing of various complex parts. The grinder is mainly used for ultra-finishing of precision parts and can achieve high-precision surface finish. The drilling machine is equipped with a multi-axis linkage system, which can process complex hole systems. In addition, the company also has advanced testing equipment, such as three-coordinate measuring machines, optical measuring machines, etc., which can perform high-precision measurement and testing on the finished workpieces to ensure the accuracy and quality of the products.



The company pays attention to the maintenance and care of the equipment, and regularly inspects, maintains and repairs the equipment to ensure the normal operation and service life of the equipment. At the same time, professional equipment operators have undergone rigorous training and are able to skillfully operate these high-end equipment to provide customers with high-quality processing services.

Frequently Asked Questions

1. Can the internal of the robotic arm be connected to an air hose?

Answer: Some series of robotic arms support the routing of air hoses or direct lines internally.

2. Can the robotic arm be mounted inverted or horizontally?

Answer: Some models of robotic arms, such as the 2442, support inverted mounting but do not currently support horizontal mounting.

3. Is the robotic arm controlled by a PLC?

Answer: Due to protocol restrictions, direct communication between a PLC and the robotic arm is not currently supported. However, the arm can communicate indirectly with the standard upper computer, HitbotStudio, or custom development software to control the robotic arm. The robotic arm itself is equipped with a certain number of I/O interfaces for signal interaction.

4. Can the software run on an Android system?

Answer: Currently, it is not supported. The standard upper computer, HitbotStudio, can only run on Windows systems (7 or 10). However, Hitbot provides a development kit (SDK) for Android systems, allowing users to develop their own applications to control the arm according to their needs.

5. Can a single computer or industrial computer control multiple robotic arms?

Answer: HitbotStudio supports simultaneous independent control of multiple robotic arms. Simply create multiple job flows. Under one host IP, you can control up to 254 robotic arms (in the same network segment). The actual situation also depends on the performance of the computer.

6. What is the role of server.exe in the SDK development kit?

Answer: server.exe is a server program responsible for data information exchange between the robotic arm and user programs.

7. Can the robotic arm be used in conjunction with machine vision?

Answer: Currently, the robotic arm cannot directly cooperate with vision systems. However, users can communicate with the arm through HitbotStudio or custom-developed software to receive relevant vision data and control the robotic arm. Additionally, HitbotStudio software includes a Python programming module for developing custom modules directly.

8. The new version of the software cannot be opened. Even after installing Microsoft Runtime Libraries and the Hitbot control software environment, it still doesn't work. What should I do?

Answer: If the upper computer software for the robotic arm cannot run properly on the customer's computer, try running it as an administrator. If there are crashes, check if the Microsoft Runtime Libraries are installed. If the robotic arm cannot be found, check the local IP and firewall settings. Note that if the software is installed in a different directory, the hitbot_server executable in the previous firewall's allowed program list needs to be added again for the new directory.

9. Which programming languages are supported by the SDK development kit?

Answer: Currently, the SDK supports C#, C++, Java, LabVIEW, and Python. It is compatible with Windows, Linux, and Android systems.

10. If the software is set to start automatically when the computer boots up, why doesn't it respond after the computer starts?

Answer: Setting the software to start automatically upon booting is often considered a potentially malicious behavior by the system or antivirus software. Firstly, add HitbotStudio to the whitelist in the computer's built-in defense system, and then add HitbotStudio to the registry to achieve automatic startup.

11. Why does the new version of the software freeze?

Answer: Make sure that the system has more than 8GB of available memory. Currently, excluding system usage, HitbotStudio consumes around 2GB of memory. Generally, ensuring that the hardware has more than 8GB of memory should allow the software to run smoothly.

12. Why does switching between two software versions cause the script to not work properly?

Answer: Currently, HitbotStudio is backward compatible with flow files. Flow files created with a lower version of the software can be opened in a higher version. However, once a flow file is opened in a higher version, it cannot be opened again in a lower version. This is because the higher version of the software has made modifications and additions to the underlying code, and when using the higher version, the functionality is updated accordingly. The lower version cannot recognize these updates, resulting in the inability to use the flow file. It is recommended to backup the flow files when switching between versions.

13. Why can't system inputs and outputs be canceled?

Answer: Currently, canceling system inputs and outputs requires being in the initialization state and stopping the flow. Sudden switching can cause the flow to run multiple times, which can lead to potentially dangerous situations.

14. Will the flow stop when the computer screen is turned off during operation?

Answer: Turning off the computer screen will cause the system to stop running, and the software will no longer continue operating. You will need to reactivate the system. If this problem occurs, you can set the screen off setting to "Do not sleep."

15. Is there a simpler method to modify the speed of each waypoint without individually editing each waypoint?

Answer: Currently, it is necessary to adjust the speed in different scenarios and consider important waypoints, less important waypoints, and transitional waypoints during waypoint execution. These three types of waypoints generally have different speeds set.

16. How much current can the DB15 connector on the robotic arm withstand?

Answer: The connector can handle 1A of current. The maximum current for internal power supply lines is 1A, and the maximum current for signal lines is 500mA. The J3 and J4 input/output ports can simultaneously output 1A.

17. What is the spacing of the pluggable terminal blocks on the robotic arm's I/O extension?

Answer: The pluggable terminal blocks used for the robotic arm's I/O extension have a spacing of 3.5mm.

18. Can the Z-EFG gripper move with a single finger?

Answer: No, please contact the sales personnel for specific information.

19. What is the gripping force of Z-EFG-8S/12/20 and how can it be adjusted?

Answer: The gripping force of Z-EFG-8S can be adjusted manually and ranges from 8N to 20N. The gripping force of Z-EFG-12 is 30N and cannot be adjusted. The default gripping force of the standard version of Z-EFG-20 is 80N. The 485 version of Z-EFG-20 (Z-EFG-20P) can communicate and adjust the gripping force. If customers require a different gripping force, they can request customization when purchasing, and the factory will set it accordingly.

20. How can the stroke of Z-EFG-8S/12/20 be adjusted?

Answer: The stroke of Z-EFG-8S and Z-EFG-12 cannot be adjusted. The pulse-type Z-EFG-20 gripper has a stroke of 20mm, with 200 pulses corresponding to 20mm. Each pulse corresponds to 0.1mm of travel. The stroke of the 485 version of Z-EFG-20 (Z-EFG-20P) can be adjusted through communication.

21. For the pulse-type Z-EFG-20 gripper, if 300 pulses are sent, what will happen?

Answer: In the standard version of the pulse-type Z-EFG-20 gripper, the additional pulses will not be executed and will have no effect.

22. For the pulse-type Z-EFG-20 gripper, if 200 pulses are sent and the gripper grips an object at 100 pulses, will it stop? Will the remaining pulses continue to move?

Answer: Once the gripper grips an object, it will maintain its position with a fixed gripping force. After the external force releases the object, the gripper will continue its movement.

23. How can we determine if the electric gripper has gripped an object?

Answer: For the I/O series of Z-EFG-8S, Z-EFG-12, and Z-EFG-20, only the stopping of the gripper can be detected. In the case of the pulse-type Z-EFG-20 gripper, the number of feedback pulses reflects the current position of the gripper, allowing users to judge whether an object has been gripped based on the number of pulses.

24. Is the electric gripper Z-EFG series waterproof?

Answer: No, it is not waterproof. For special requirements, please consult the sales personnel.

25. Can Z-EFG-8S or Z-EFG-20 grippers be used if the object to be gripped is larger than 20mm?

Answer: Yes, the specifications of Z-EFG-8S and Z-EFG-20 refer to the effective stroke of the gripper, not the size of the object to be gripped. Z-EFG-8S can be used to grip objects with a maximum size difference within 8mm, and Z-EFG-20 can be used for objects with a maximum size difference within 20mm. Please note that different grippers have a certain range of allowable eccentric torque. Use them within the allowed range, and an excessively long eccentric gripping position may result in a decrease in gripping force.

26. If the electric gripper keeps working continuously, will the motor overheat?

Answer: Through professional testing, it has been determined that the Z-EFG series grippers, when continuously working in an ambient temperature of 30 degrees Celsius, have a temperature rise of no more than 35 degrees Celsius. The Z-EMG-4 electromagnetic gripper may become relatively hot due to its operating principle, so please be aware of the high-temperature warning.

27. Does the Z-EFG-100 gripper support I/O or pulse control?

Answer: Currently, Z-EFG-100 only supports control via 485 communication. Users can manually set parameters such as motion speed, position, and gripping force.

28. Does the gripper product include the front-end gripping part?

Answer: No, it does not. Users need to design the gripping fixture according to the actual objects to be gripped. In addition, Hitbot also provides a small library of fixtures. Please contact the sales personnel for more information.

29. Where is the driver controller for the gripper located, and do I need to purchase it separately?

Answer: The driver controller is built-in and does not need to be purchased separately.

30. How can I view the model and corresponding wiring sequence of the gripper?

Answer: Please refer to the corresponding product manual.

31. Why does the Z-EFG-100 gripper have no force when powered on?

Answer: The Z-EFG-100 gripper does not generate torque when only powered on. It needs to be calibrated before it can generate torque.

32.What could be the cause of intermittent non-action in the Z-EFG-8SNK gripper?

Answer: The control signal of the Z-EFG-8SNK gripper is susceptible to interference. If customers need to use longer cables or the signal environment is complex, it is recommended to use an optocoupler isolation board near the gripper to avoid interference.

33.What should I do if the Z-EFG-20PM gripper does not provide feedback on the feedback line?

Answer: The feedback pulses of the 20PM gripper can be connected to a PNP PLC high-speed counter. Please note that the COM terminal of the high-speed counter port should be connected using the common anode method. Also, connect the 24V feedback pulse line of the 20PM gripper. When the gripper fingers are not moving, it should be at a high level for 20NM and 0V for 20PM.

34.Can the gripper ID and baud rate be modified?

Answer: The provided upper computer software can be used to modify the gripper ID and baud rate, and the modification steps will be provided.

35.What is the relationship between gripping force and current, as well as rotation and current for the Z-ERG-20 gripper?

Answer: The gripping force ranges from 10N to 35N for a current range of 0.1A to 0.5A. The rotation torque ranges from the minimum torque to $0.3N \cdot m$ for a current range of 0.2A to 1.0A. There is a linear relationship with an error of $\pm 10\%$.

36.How to wire and debug the Z-ERG-20 gripper?

Answer: Red is positive, black is negative, yellow is for 485 communication positive, and white is for 485 communication negative. You also need to connect the 485 module to a computer for debugging.

37.How can I control the gripper via 485 communication?

Answer: Control message examples will be provided, and the content needs to be written as hexadecimal floating-point numbers.

38.What is the CRC calculation model?

Answer: The reference model is $CRC\text{-modbus}16x6+x15+x2+1$.

39.How can I adjust the gripping force of the Z-EFG-20 gripper?

Answer: On the side of the gripper housing, there are three small holes, and the leftmost hole is the potentiometer knob. Turning the knob counterclockwise increases the force, while turning it clockwise decreases the force. The rotation angle should not exceed ± 120 degrees. Use a small screwdriver to adjust it, and the maximum adjustable force is around 100-120N.

40.Motion element grease supply period?

Every 6 months or 1 million times actions



Making Automation Easier

Huiling-tech Robotic Co.,Ltd.

Tel: 152 2025 9858

Email: Marketing@hitbot.cc

Website: www.hitbotrobot.com

Address: 2nd Floor, Building E, Huafeng International Robot
Industrial Park, Hangcheng Ave, Xixiang St, Baoan District,
Shenzhen City, Guangdong Province, China



[HITBOT official website](http://www.hitbotrobot.com)

version: V_2025.05.01