



Section

Contents

Page

Intro

About

04

Services

05

Testimonials

06

Work

IYO

07

Applied Intuition

13

Perplexity Comet

19

Air Space Intelligence

25

Consensys

31

Path Robotics

37

Esther

43

Coinshift

49

Bad Boys

55

Closing

Contact

61



STUDIO FREIGHT builds brands, digital experiences, campaigns, and special projects to move missions forward. Our clients see us as trusted partners who care as much as they do but it's a ruse because we actually care more.

One studio, many missions. We work with **CATEGORY** leaders, renegade startups, eccentric celebrities, and modest operators making a silent killing.

Links

[Website ↗](#), [Instagram ↗](#), [LinkedIn ↗](#), [Vimeo ↗](#), [Aeon ↗](#)

Clients

Netflix
 Perplexity
 MetaMask
 Consensus
 Sharplink
 Mercury
 Brex
 Vercel
 ElevenLabs
 Applied Intuition
 La Marzocco
 First Round
 Drive Capital
 Dragonfly

SeatGeek
 Root Insurance
 Patrick Mahomes
 Loop Returns
 Bad Boys
 Middesk
 Pendo
 Easol
 FalconX
 Polygon Labs
 Hyperbolic Labs
 LaunchDarkly
 Lunchbox
 & More

Features

RRE on Klim Type ↗
 Applause on Brand New ↗
 Perplexity on The Manifest ↗
 Brex on The Brand Identity ↗
 Dragonfly on Awwwards ↗

Contact

hello@studiofreight.com



We **TRANSPORT** our partners from where they are to where they want to be. Our global team uses strategy, design, experience, and mettle* to help brands leave the ordinary behind. Explore working with us.

Services

(01) Brand & Identity Design

We build the foundational brand systems that make your company easy to understand and impossible to ignore. Strategy-first or build-first, we meet you where the mission needs to start.

(02) Website Design & Development

We design and engineer digital experiences that work as hard as the brands behind them. Timelines and budgets vary based on content requirements, technical complexity, and success criteria.

(03) Campaigns & Activations

We approach launches and experiences like they only have one shot. Because they do. No idea is too wild or ambitious as long as it means something to the people it reaches.

Inflections

While every client partner (and mission) is different, they generally come to us to move through an important inflection point.

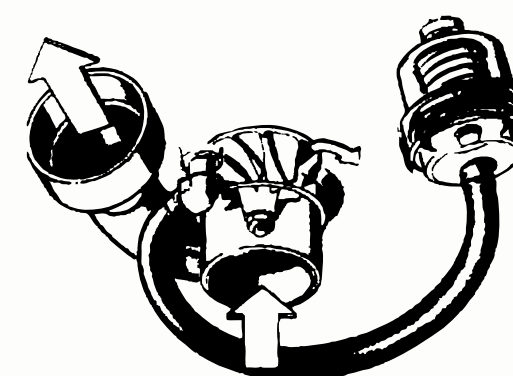

- └─ Launching a new product or service
- └─ Preparing for rapid go-to-market scale
- └─ Expanding reach with campaigns or events
- └─ Repositioning the the brand for resonance
- └─ Augmenting team bandwidth limitations
- └─ Changing their narrative or category
- └─ Merging or restructuring businesses
- └─ Improving the sales experience
- └─ Reigniting company culture

(⇒) Mettle

[met-1] noun / a person's ability to cope with difficulties or to face a demanding situation in a spirited and resilient way

* We bring expertise, experience, and pragmatic optimism to every project to turn even the most side-eye ideas into brow-raising results.



“I think the best way to describe Studio Freight is to say that they’re my partners. Actually, even better than partners, they’re like an extension of myself and my company. Why do I say that? Because working with them felt like finding my voice all over again. They were able to translate what I asked for into something even better. That’s so important and rare, and the difference that makes it a true partnership.” — Nabeel Alamgir, Founder & CEO, Lunchbox

“Working with Studio Freight was exactly what we needed. The experience was great, but more importantly led to an award-winning brand and website that helped us raise \$156 million. The VCs we worked with on our Series B and C fell in love with our brand and how we were executing it. None of that would have been possible without Studio Freight.” — Tim Trad, Head of Brand & Creative, Path Robotics

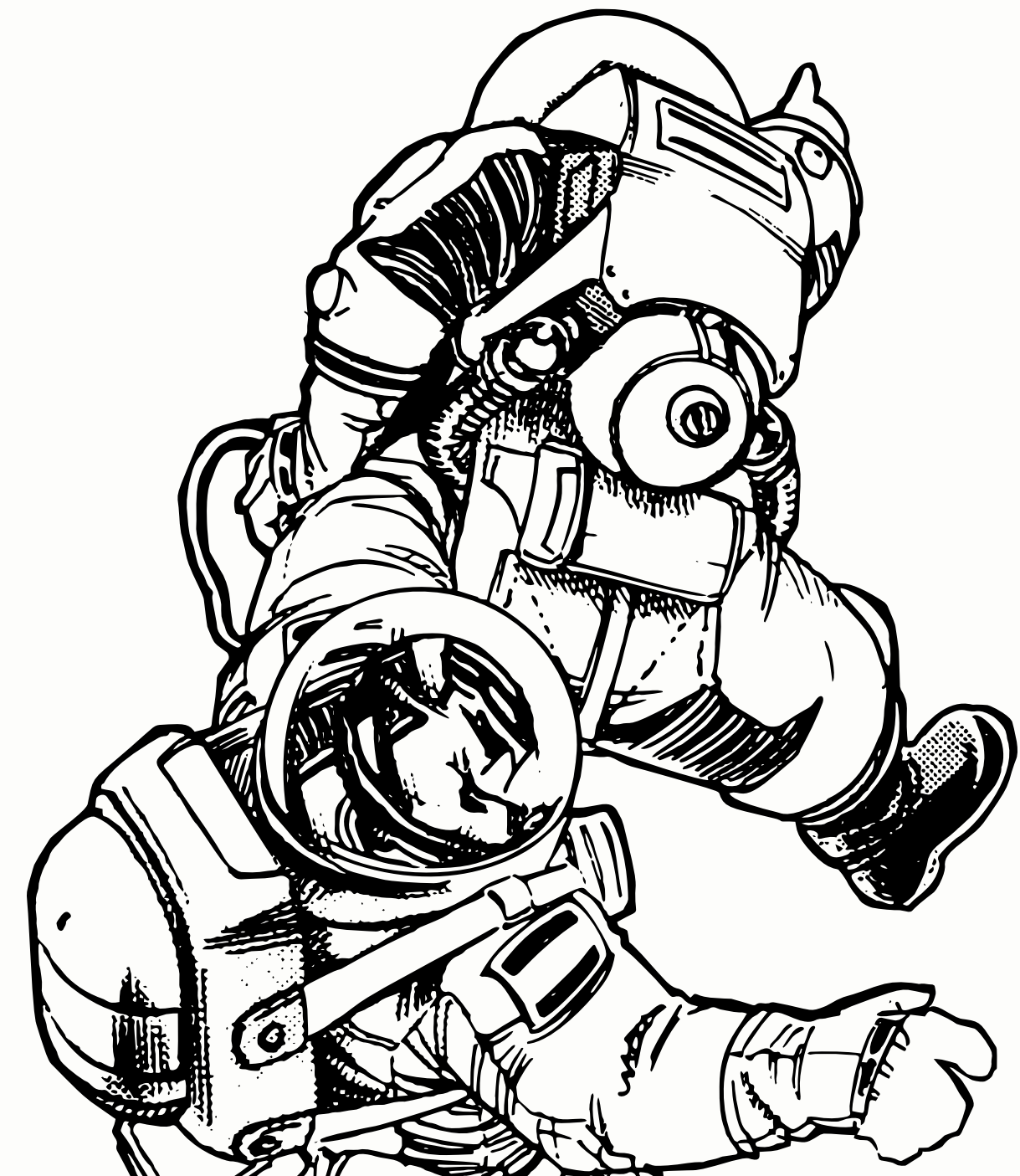

“Agency projects can feel transactional. But this never did. We came to Studio Freight with a truly impossible ask and a tight turnaround time. From concept to execution, the Studio Freight team translated our idea and elevated it. Every detail across planning, design, copy, print, and digital was thoughtfully handled. Their team had a clear, well-run system for us to step into, which gave us a confidence throughout the project. We never had to chase next steps. The clarity and pace of their workflow was inspiring, so much so that we’ve since looked to it as a model in refining our own. La Marzocco is a legacy brand. It’s not easy to find partners — let alone a team — who can hold that legacy with care while also bringing something of their own. We’re excited to see where Studio Freight can take us next.” — Ben Blake, Marketing and Creative Director, La Marzocco

“Working with Studio Freight was an amazing experience from start to finish. What I valued most was their deep understanding of both design and storytelling, they took the time to understand my work, my audience, and how to translate that into a site that truly reflects my career and creative vision. The team’s attention to detail, technical execution, and ability to bring personality into the design made the process smooth and inspiring. The outcome was a clean, modern and cinematic website that feels alive and authentic to who I am as an artist.” — Ben Mauro, Concept Artist, Huxley

“I can’t say enough good things about Studio Freight. I worked with them to refresh the branding and website and they were an absolute joy to work with — seriously the best practices and process I’ve seen in a studio. Call them for any digital and branding needs. They are the best.” — Sandra Nam, Chief Strategy Officer, Psyop

“Undeniable creative monsters. Studio Freight is a must-hire agency for any marketers looking to undertake a massive rebrand... The work is pure genius.” — Hillary Adler, VP of Marketing, Thesis

“Choose Studio Freight if you believe your website is your company’s internet headquarters that defines your brand and boosts your customer adoption. We sure did, and we couldn’t be happier with our decision! Not only are they absolute pros, but they’re also super responsive and genuinely great people to work with. If you want your website to stand out (and make your competitors jealous), Studio Freight is the way to go!” — Jasper Zhang, CEO & Founder, Hyperbolic Labs

“We could not have had a better experience working with a creative agency than we did working with Studio Freight. The quality of their creative is self-evident. Their ability to ask questions early in the process ensured that the look and feel of their work supported our mission and vision. They’re total pros and good people. You don’t have to enjoy having a beer with the people you work with but it certainly doesn’t hurt.” — Nils Root, Partner, Drive Capital

“We are so very impressed and grateful for the drive, hustle, and quality work from Studio Freight. It’s beautiful, **BEAUTIFUL**. I love how the new design system is showing up, it’s fresh and sharp, yet still feels approachable. Truly world class.” — Karen Tillman, Chief Comms Officer, Brex

“Working with Studio Freight was such a great experience. Not only is it really hard finding a studio that really understands the goal and ethos of a client/customer quickly, but it’s even harder to find a studio with such fun team members that take their work seriously while being incredibly enjoyable to work with. It was such a privilege to work alongside them; I learned a ton of things and they were so humble and patient in understanding our needs. They’re a powerhouse of a team, putting in blood sweat and tears to get amazing deliverables, and I would gladly work with them again for any future projects!” — Michelle Yuan, Brand Designer, Applied Intuition

“On top of just being an incredibly easy and fun group of people to work with, I think the thing about Studio Freight that I was most blown away by was just the passion and creativity of the team. I feel like we’d meet one week, jam on a few ideas, and then a week or two would pass by and the team would generate a massive collection of different, high-fidelity concepts, all of which checked so many of the constraints that we were operating in for the project. I think this comes from this unique marriage of incredible skill and love for the work that I’ve seen working with the team, all of which makes them a delight to partner with.” — Tom Schmidt, General Partner, Dragonfly



IYO

Overview

Hear the world according to you. With no screen, no keyboard, and no friction between thought and action, IYO protects your inner world as a computer you talk to.

Services

Strategy
Messaging
Verbal Identity
Visual Identity
Creative Direction
Digital Design
Development

Links

[Case ↗](#)

iyO™



INSPIRED
BY
THE
REAL
WAYS
PEOPLE
CONVERSE,
WE CREATE
TRULY PERSONAL
IN-EAR
TECHNOLOGY.
INSPIRED
BY
THE
REAL
WAYS

iyO™

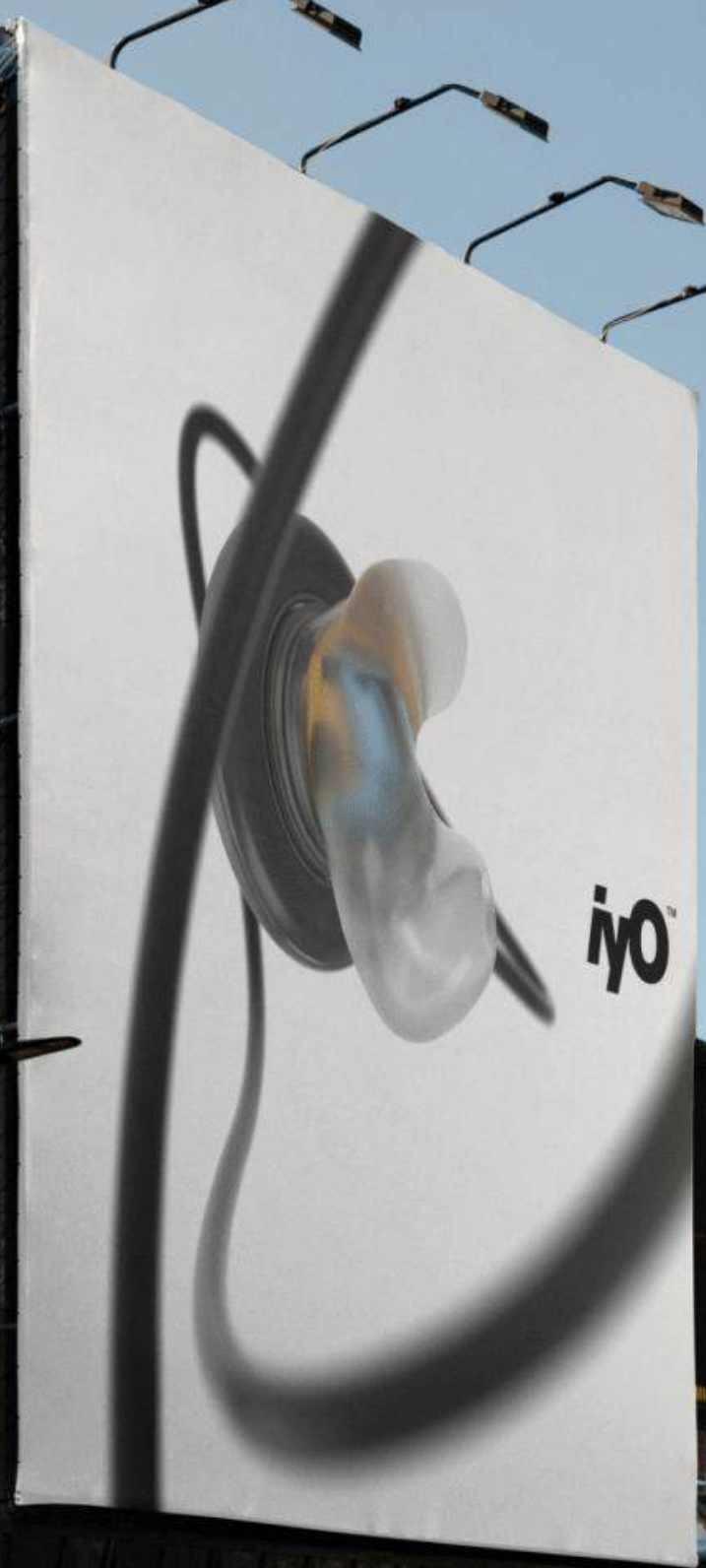

CAR PARK
ENTRANCE
FIRST RIGHT

↑
P

↑

VAD PRO

iyO™

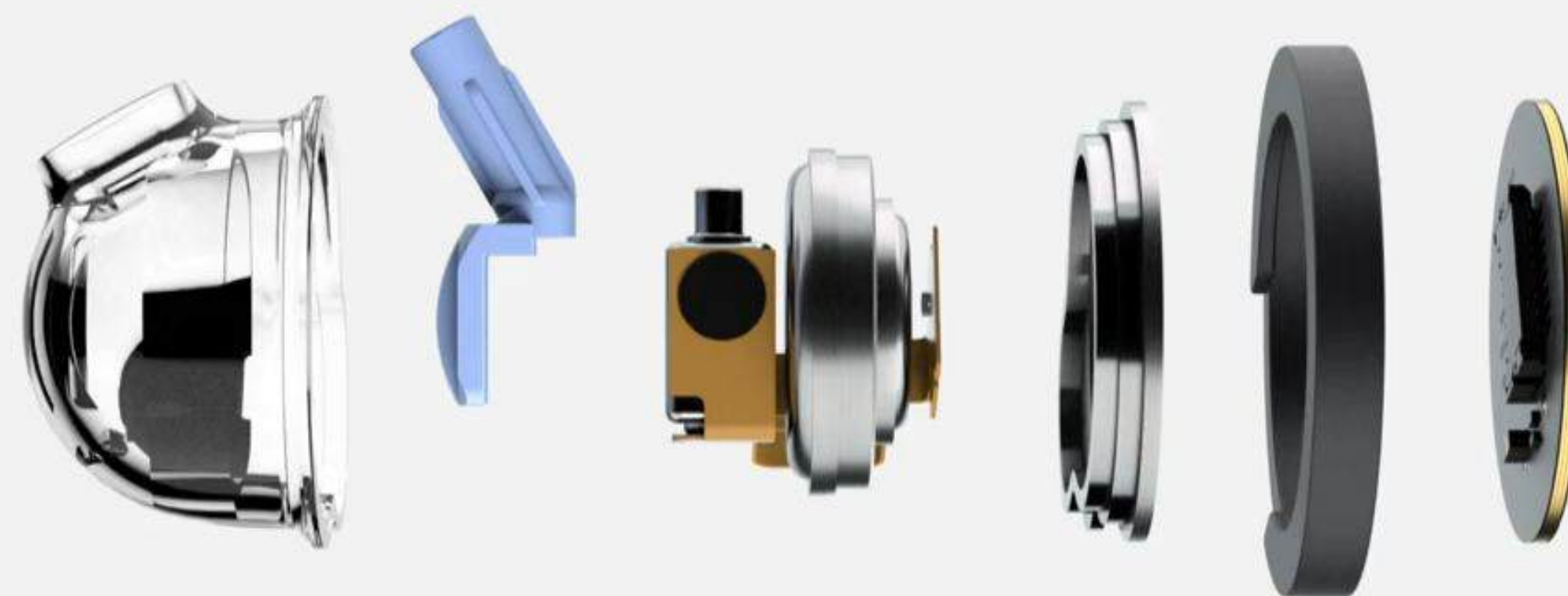

A STUDIO
IN YOUR POCKET

IYO.AUDIO

inyo™

01
SUDAN ARCHIVES
PRODUCER

02
JAMES BLA
PRODUCE



iyO™

LIFT YOUR EYES
FROM YOUR SCREEN

iyO™

IYO.AUDIO





APPLIED INTUITION

Overview

Physical AI that drives the world. Applied Intuition supplies the simulation and autonomy stacks for 18 of the top 20 automakers. Now the industry builds self-driving on shared automation infrastructure.

Services

Visual Identity

Applied Design

Digital Design

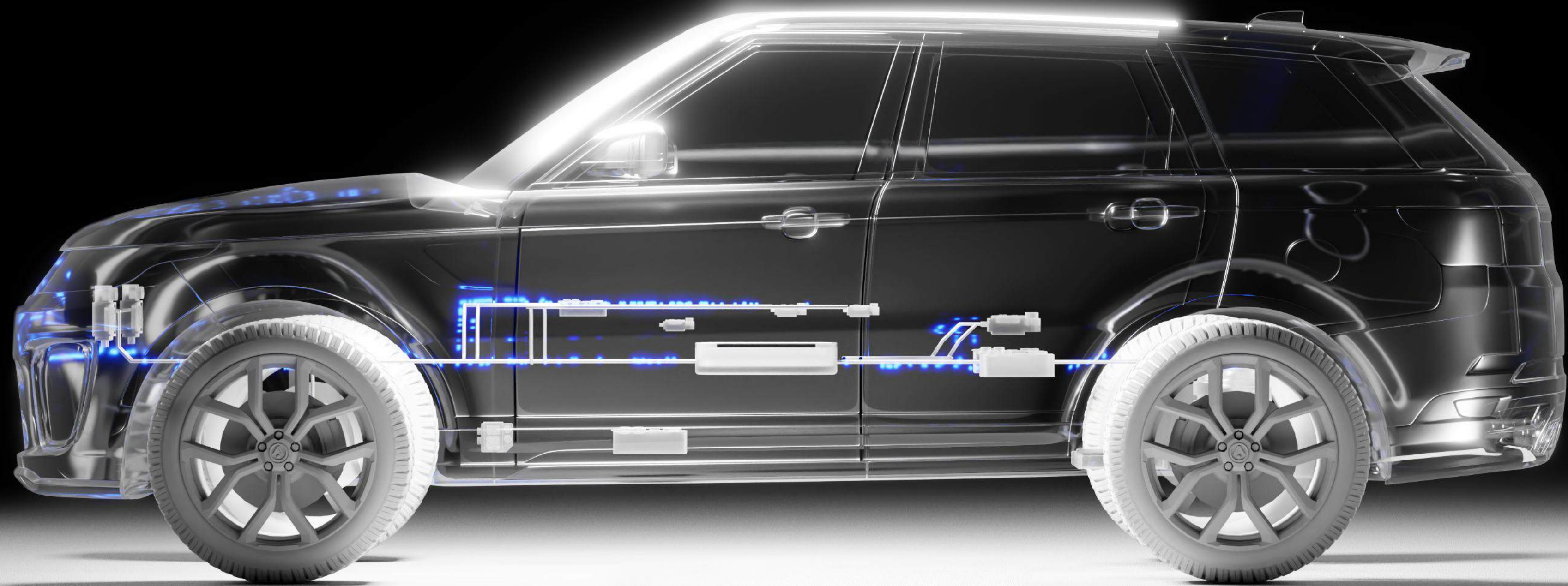



Applied Intuition ⌵

Solutions >

Products >

Customers >

Company >

[Contact us](#)

EN



Consumer Application

Contact Us

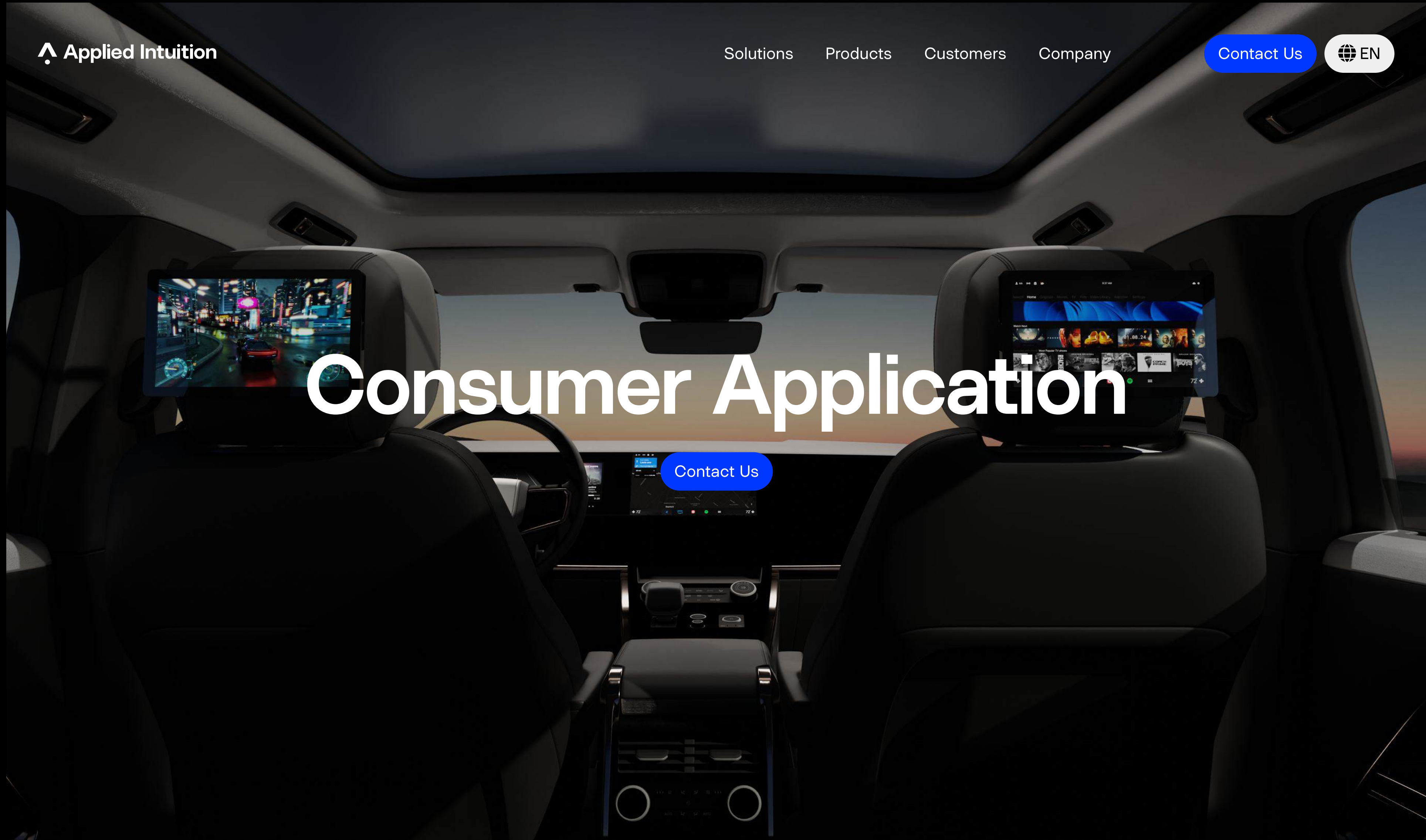

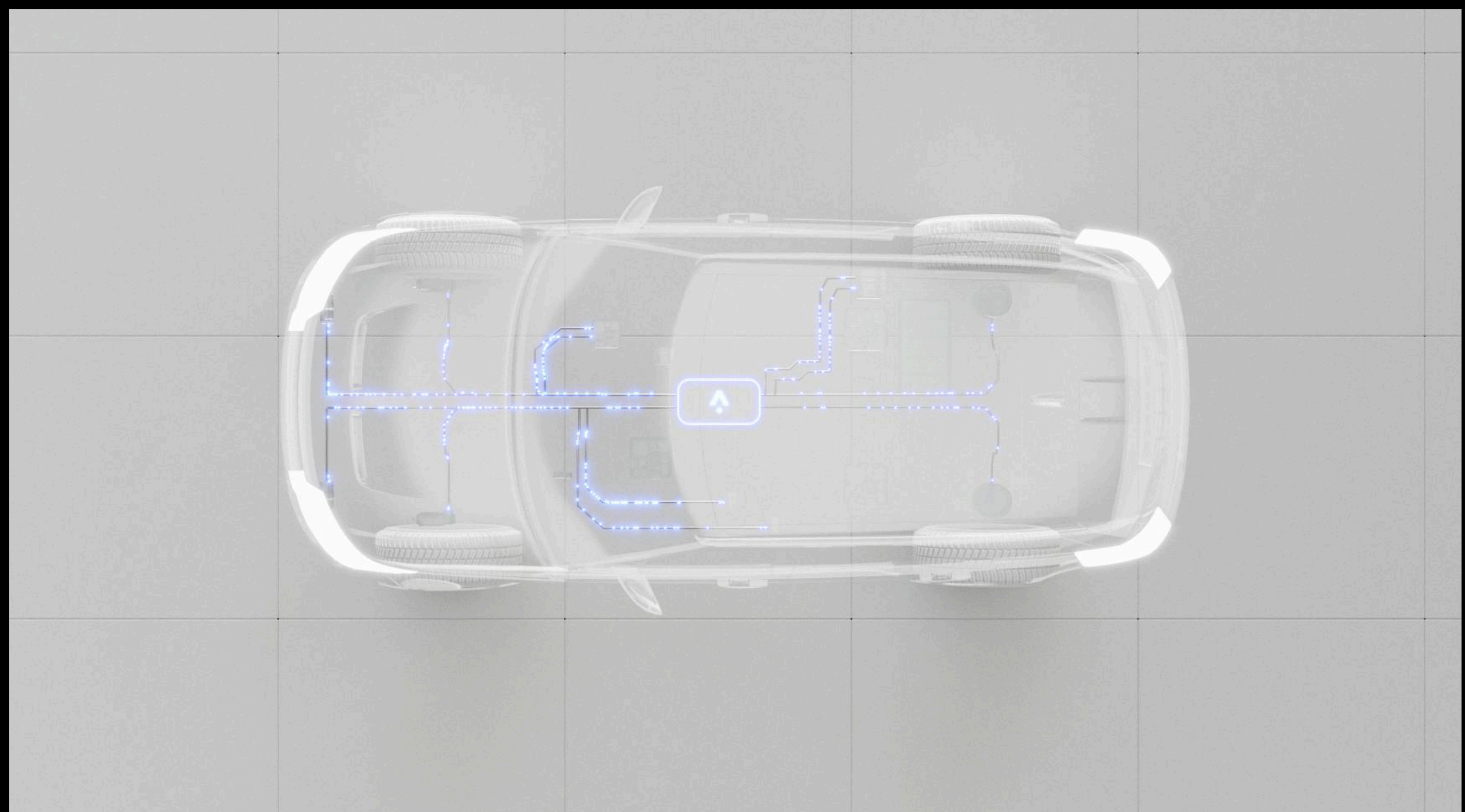
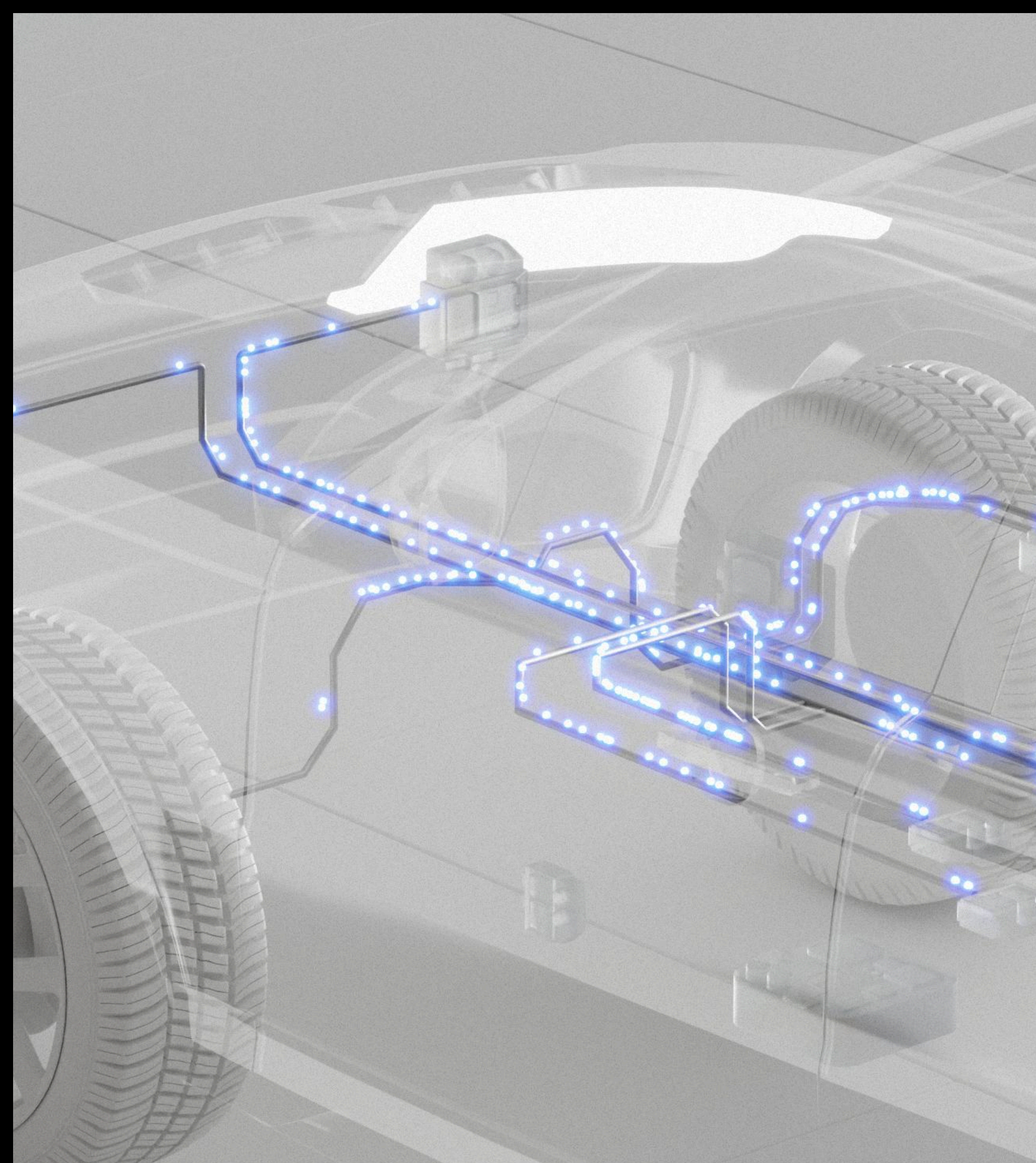

ntuition

Applied

Subscribe

Email



Solutions

[Perception & localization](#)

[Planning & controls](#)

[Log visualization & triage](#)

[Scenario creation](#)

[Verification & validation](#)

[Automated testing](#)

[Map creation](#)

[Vehicle dynamics](#)

[Euro NCAP](#)

[Sensor suite design & validation](#)

Company

[About](#)

[Careers](#)

[Blog](#)

[Press Kit](#)

[Privacy](#)

[Contact](#)





PERPLEXITY COMET

Overview

Browse at the speed of thought. Comet is the AI-powered browser Perplexity is building on top of their answer engine. A cosmic identity launches what doesn't yet exist.

Services

Creative Direction
Digital Design
Development
Campaign

Links

Case ↗
Website ↗
The Manifest ↗
The Brand Identity ↗



A cosmos of answers
awaits, ask anything

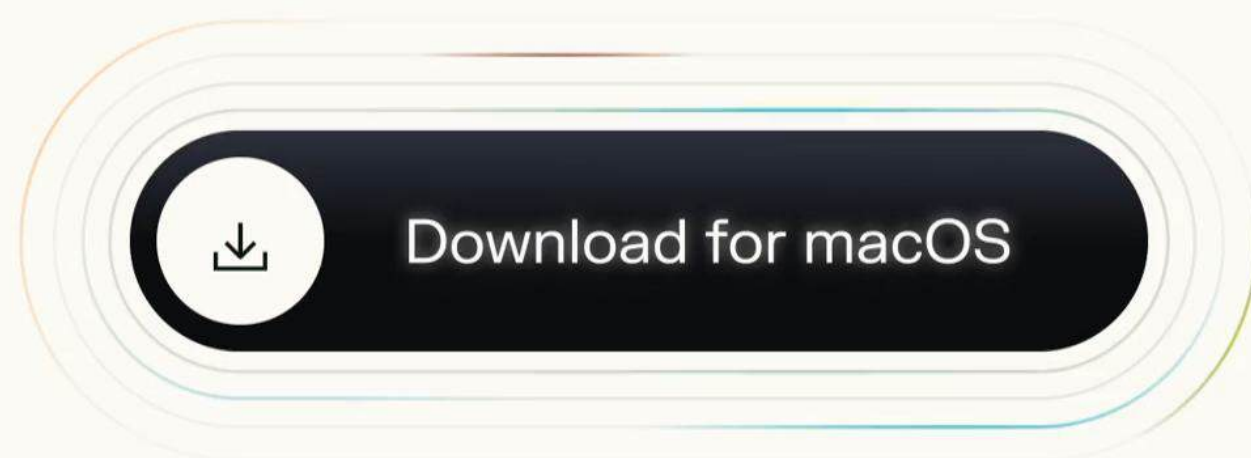

☰ Summary

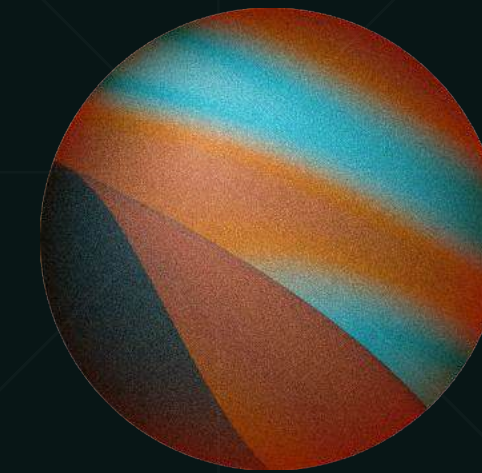

Venus

Venus is the second planet from the Sun and Earth's closest planetary neighbor, often called Earth's "twin" or "sister" due to their similar size and mass. It is the hottest planet in the solar system, with surface temperatures around 464 °C (867 °F) caused by a dense atmosphere composed mainly of carbon dioxide (96.5%) that creates a runaway greenhouse effect.

Venus has a very slow retrograde rotation, taking about 243 Earth days to complete one rotation, which is longer than its 224.7 Earth-day orbit around the Sun. It has no moons and a weak magnetosphere, with



Features

FAQs

Download

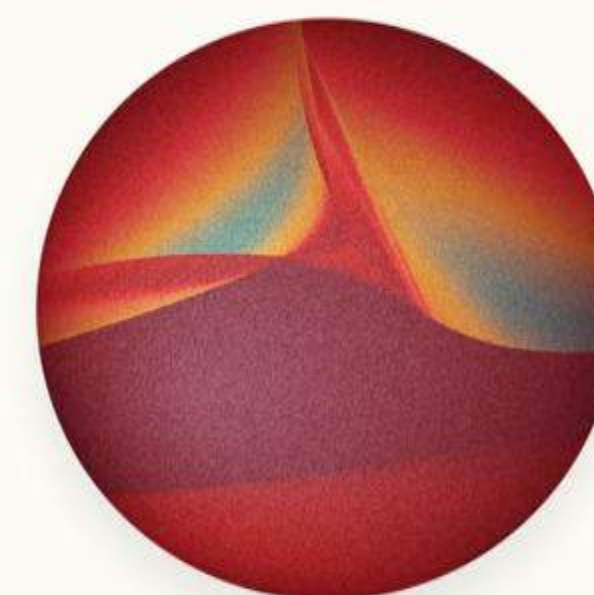
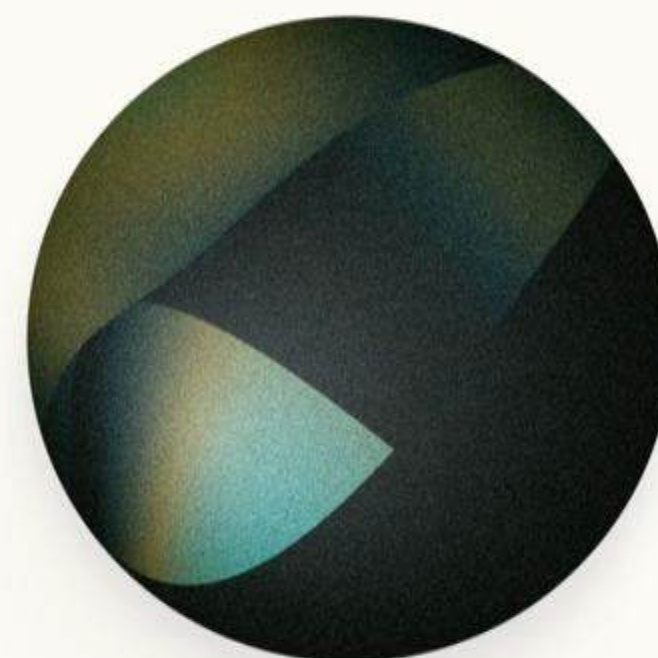
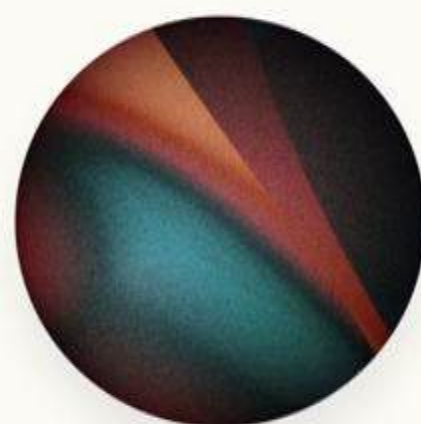
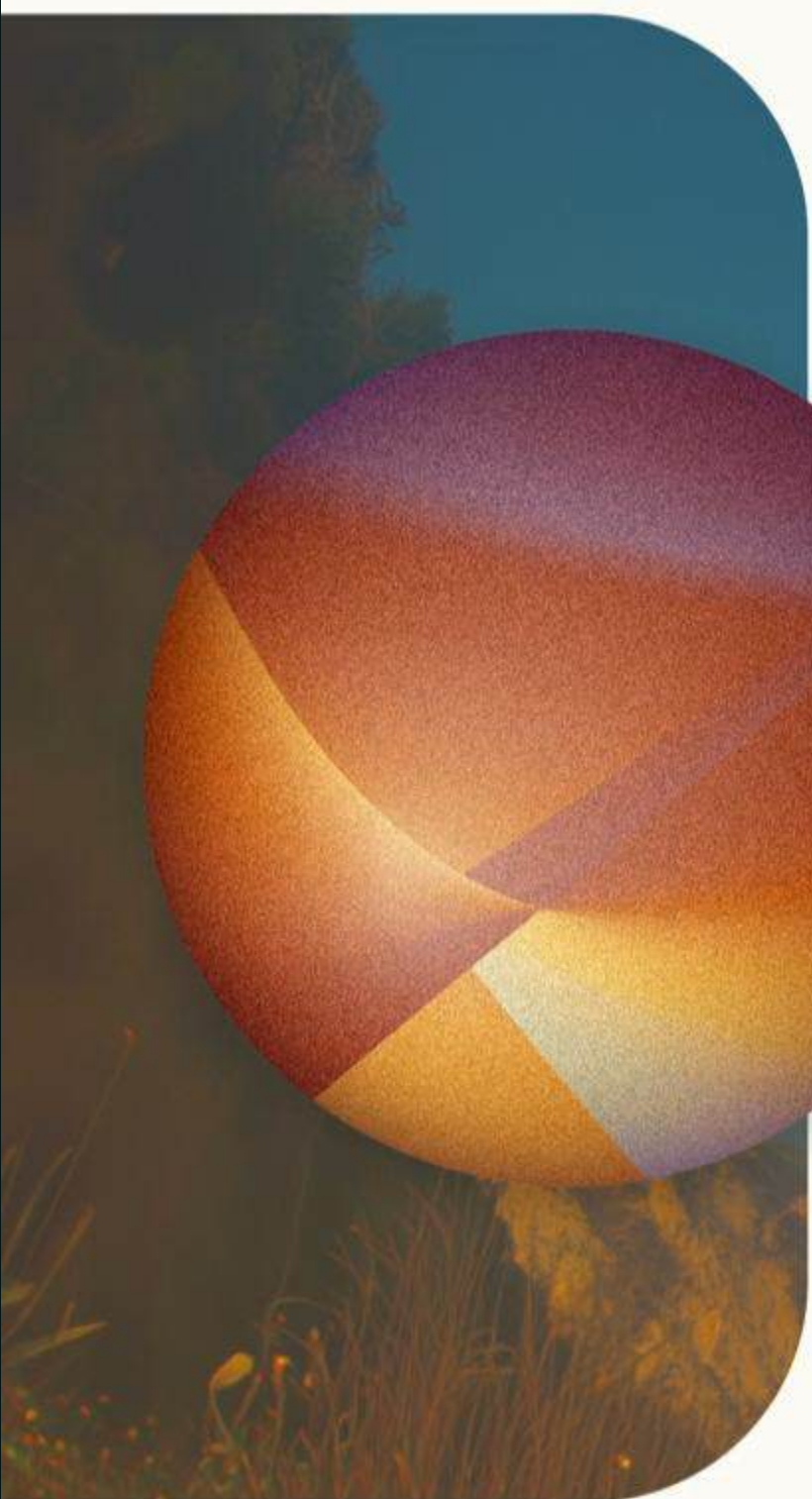





Features FAQs Download

Comet is a browser powered by [Perplexity](#)

Browse with intelligence

 Download for macOS





AIR SPACE INTELLIGENCE

Overview

Foresight, at scale. Air Space Intelligence is the predictive AI platform powering the world's most complex air operations. Now airlines and governments stay ahead of what's coming.

Services

Visual Identity
Creative Direction
Digital Design

Links

[Case ↗](#)
[Website ↗](#)





ASI

**ARTIFICIAL
INTELLIGENCE
FOR CRITICAL
DECISION-MAKING**



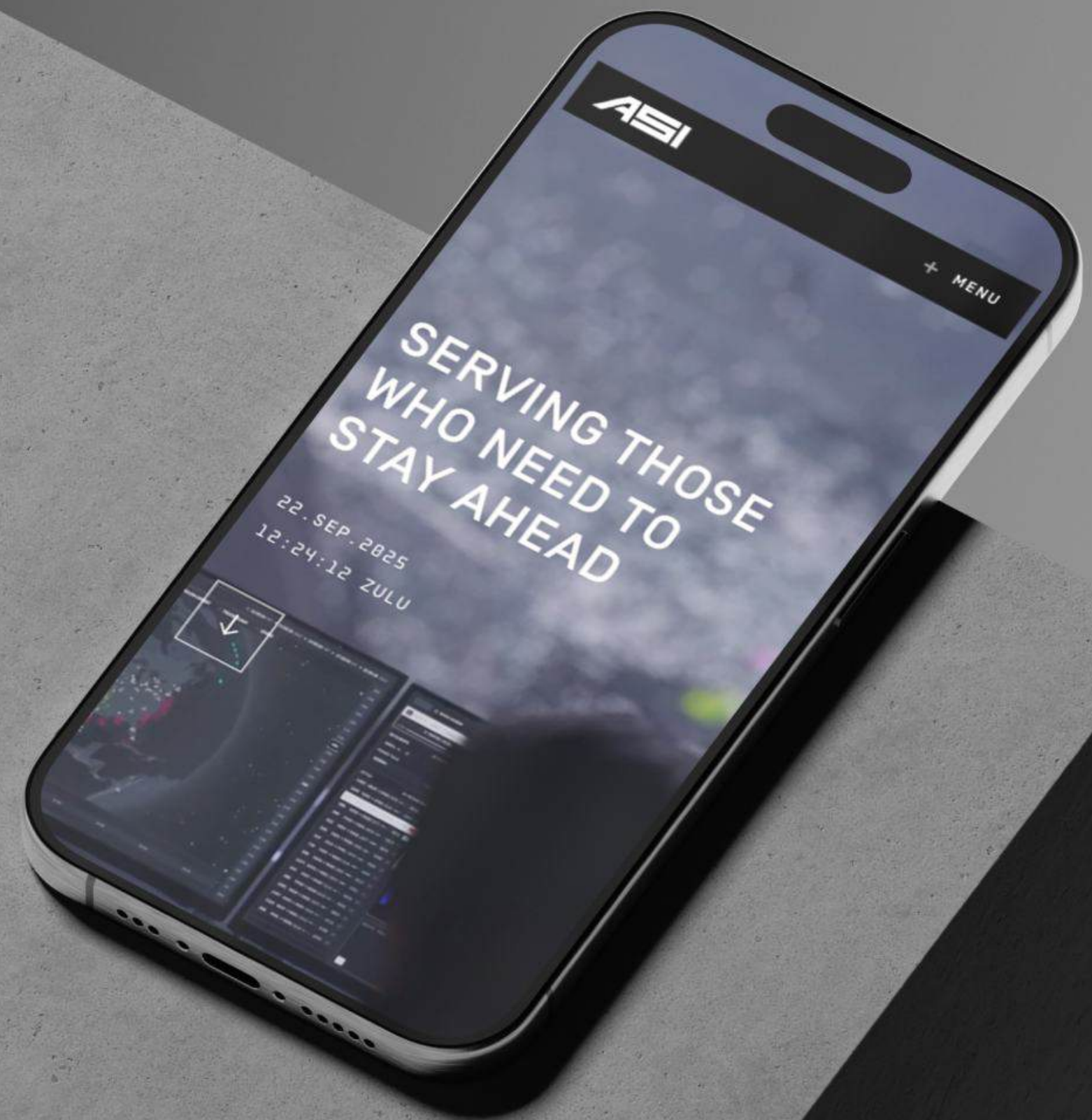
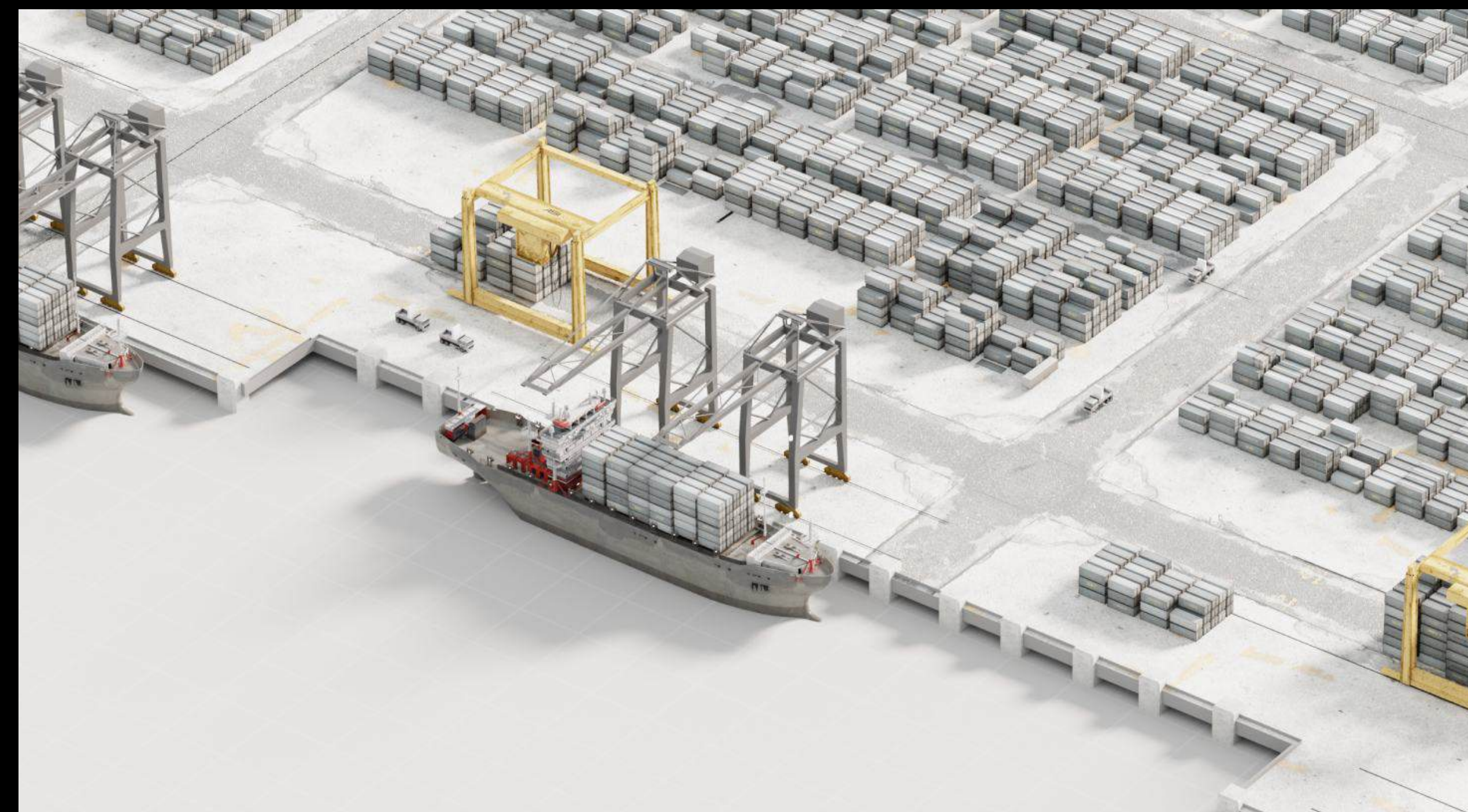
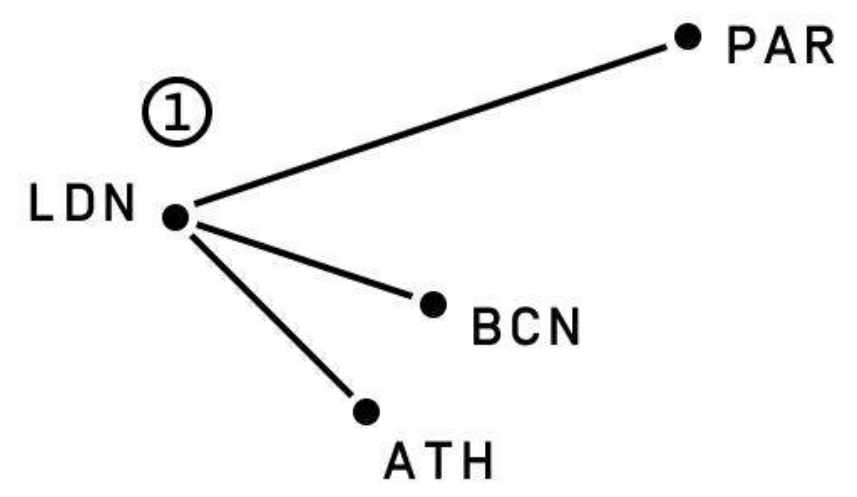

some of the most critical logistic challenges across our military and commercial sectors.

[READ MORE \[+\]](#)

INDEX

[PLATFORM](#)

[AIRLINE OPERATIONS](#)

[AIR TRAFFIC MANAGEMENT](#)

[SUPPLY CHAIN](#)

[DEFENSE](#)

[ABOUT US](#)

[CAREERS](#)

[NEWSROOM](#)

[CONTACT US](#)

OFFICES

[\[+\] ASI HQ - BOSTON, MA](#)

[\[+\] ASI FEDERAL - WASHINGTON, DC](#)

[\[+\] ASI EUROPE - GDANSK, POLAND](#)

[\[+\]](#)

[\[+\]](#)

[\[+\]](#)

[\[+\]](#)

[\[+\]](#)

[\[+\]](#)

[TERMS](#) [PRIVACY](#) © 2024 AIR SPACE INTELLIGENCE, INC.

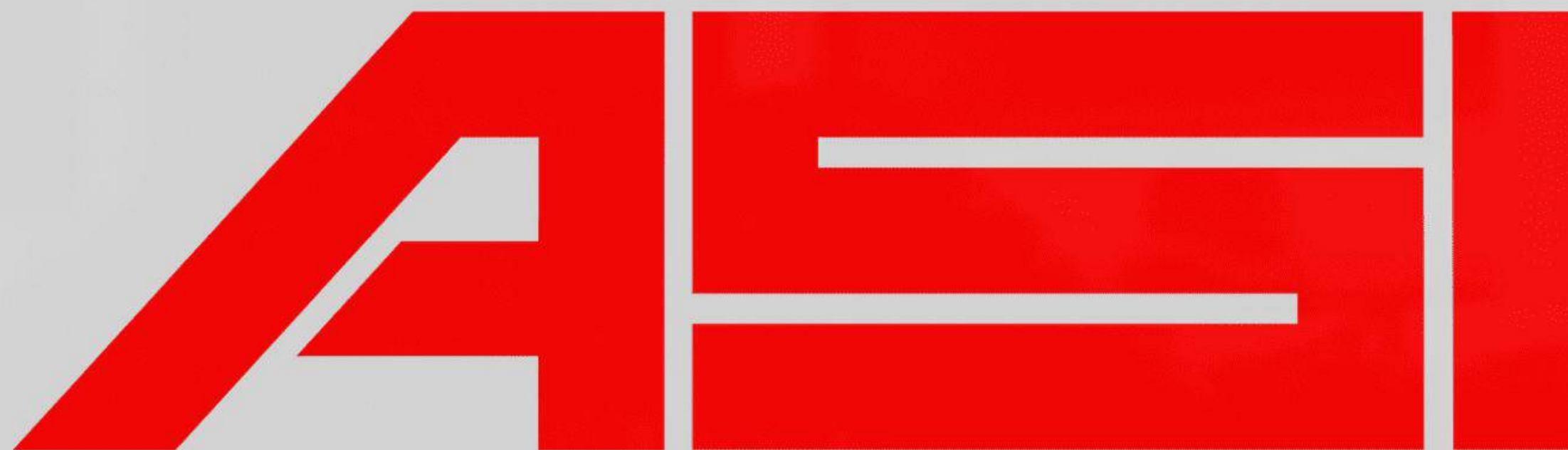



CONSENSYS

Overview

Programmable trust. Consensys has been building infrastructure for Ethereum since before the genesis block, started in 2014 by Ethereum co-founder Joseph Lubin.

Services

Applied Design
Digital Design
Development

Links

[Website ↗](#)



Products ▾

Ecosystem

Company

Blog

Explore products



The Ethereum Company

Explore our products

Learn why Ethereum

[Scroll to explore](#)

We build the tools, infrastructure, and research that power Ethereum—the foundation for a more secure, open, and programmable economy.

 Explore products 



The Future Runs on Ethereum



Ethereum is trustware that transforms trust into the digital commodity we all need and deserve for navigating the

 Explore products 

- Products →
- Ecosystem →
- Company →
- Blog →

- Twitter ↗
- Discord ↗
- YouTube ↗
- Instagram ↗



 Explore products 

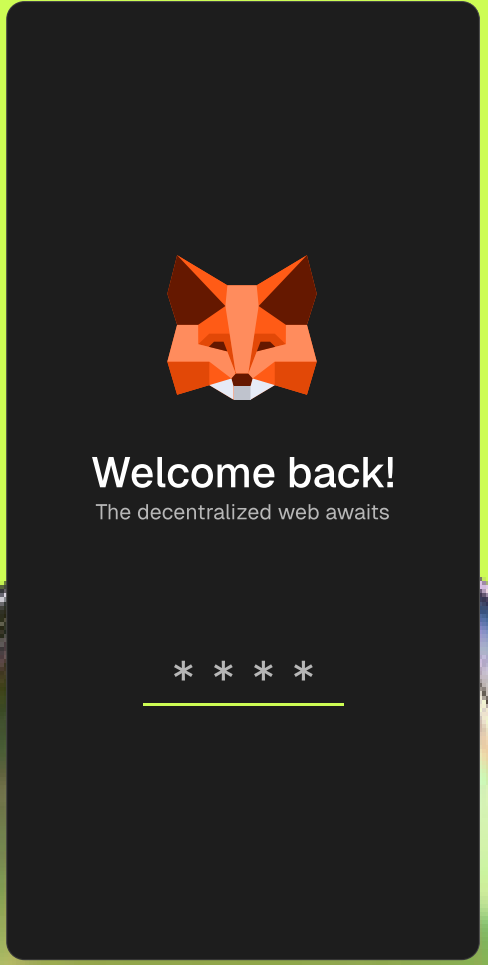



MetaMask







MetaMask is the secure non-custodial digital wallet and web3 gateway for over 100 million users annually, who trust MetaMask to buy, store, send, and swap tokens and to manage their identity on the decentralized internet.









 [Products](#)  [Ecosystem](#) [Company](#) [Blog](#)

Explore our suite of products

Products 	Protocol & Open-source 
MetaMask 	Linea
MetaMask Developer 	Teku
Infura 	Besu
Consensys Staking 	Web3Singer

[Twitter](#)  [Youtube](#)  [Instagram](#)  [Discord](#) 

OUR PRODUCTS

Our vertically integrated platform converts user and application intent into successful onchain outcomes, from authorization and routing to execution and settlement.

See all products

INFRASTRUCTURE

Infura

Infura is the original platform for web3 development, giving developers access to a robust, reliable, and integrated set of tools to easily build and scale their decentralized applications.



REQUESTS SERVED PER YEAR

2T

NUMBER OF DEVELOPERS

400k

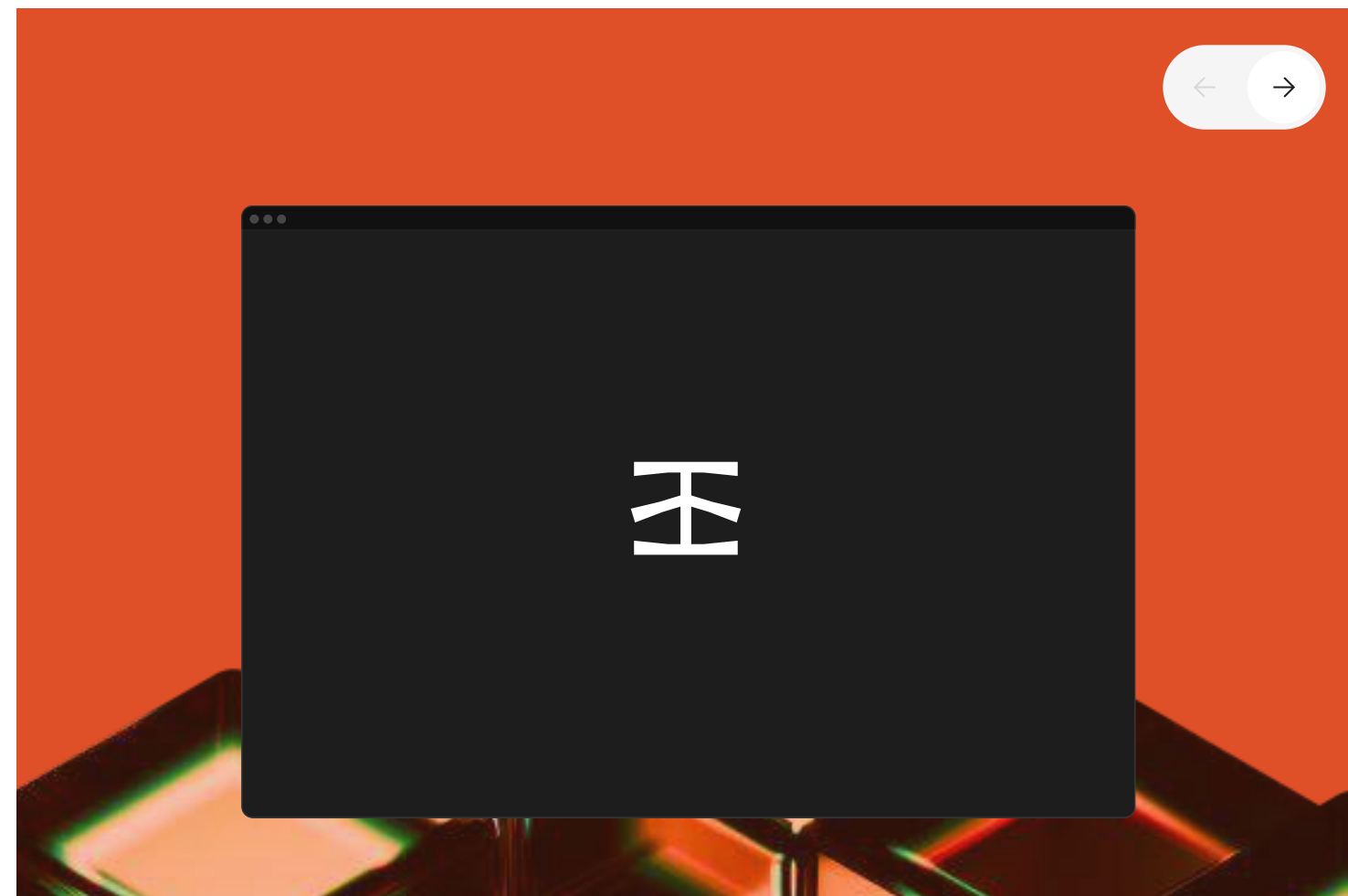

OUR PRODUCTS

Our vertically integrated platform converts user and application intent into successful onchain outcomes, from authorization and routing to execution and settlement.

See all products





Products

Company

Blog

[Home](#) > [Products](#) > [Trustware](#)

PRODUCT

For developers

[MetaMask Developer](#) ↗

[Linea](#) ↗

[Infura](#) ↗

[Diligence](#) ↗

For everyone

[MetaMask](#) ↗

For the ecosystem

[Consensys Staking](#) ↗

ECOSYSTEM

[Web3 Regulations](#)

[Web3 Workforce Survey](#)

[Future of Work](#)

[Web3 Survey](#)

[Community](#) ↗

[Ethereum Upgrade](#)

COMPANY

[About](#)

[Press](#)

[Careers](#)

[Security](#)

[Contact](#)

SOCIAL

[Twitter](#) ↗

[Youtube](#) ↗

[Discord](#) ↗

[Instagram](#) ↗

[Privacy Policy](#)

[Terms of Use](#)

[Manage Cookies](#)

[Accessibility](#)



PATH ROBOTICS

Overview

Path is delivering on the promise of what intelligent robotics can become — starting with truly autonomous welding. We worked with their team to pave a path forward for manufacturing.

Services

Strategy
Messaging
Visual Identity
Digital Design
Development

Links

Case ↗
Fonts In Use ↗
Awwwards ↗

path



Truly

Autonomous Welding





One size doesn't fit all, so we have options when it comes to making high-quality finish welding effortless for engineers and economical for manufacturers.

AW-2



The AW-2 brings autonomous finish welding to small and mid-size parts. The flexibility of the AW-2 eliminates the need for custom, rigid fixturing and precise part placement, so you can keep on cranking with minimized changeover times.

AW-3

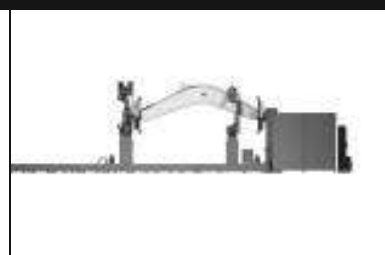
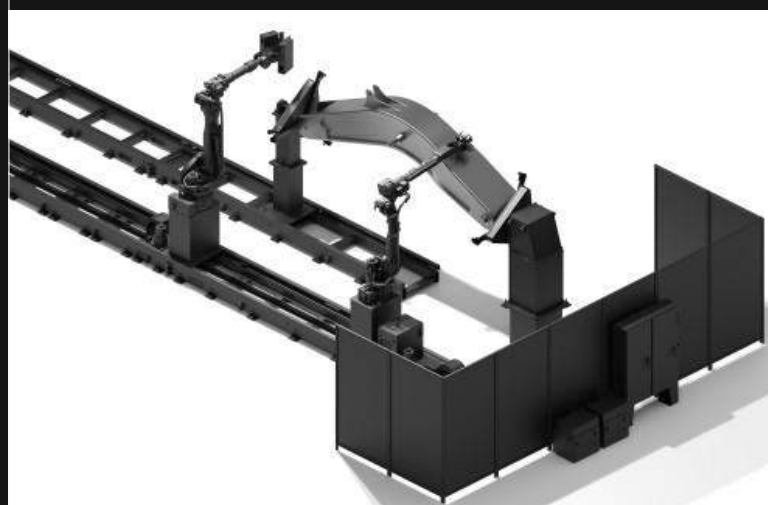

The AW-3 brings autonomous finish welding to longer parts that don't fit in smaller welding cells, yet retains the flexibility to handle small and large parts alike. The AW-3 can have one or two welding zones, where one side can weld while the other side loads and unloads.

Autonomous Welding,
Automatic ROI



- Lower costs
- Reduced churn
- Shorter cycle time
- Less labor overhead



path

Path
Robotics

It sees.
It understands.
It welds.

Fully
automated
welding.



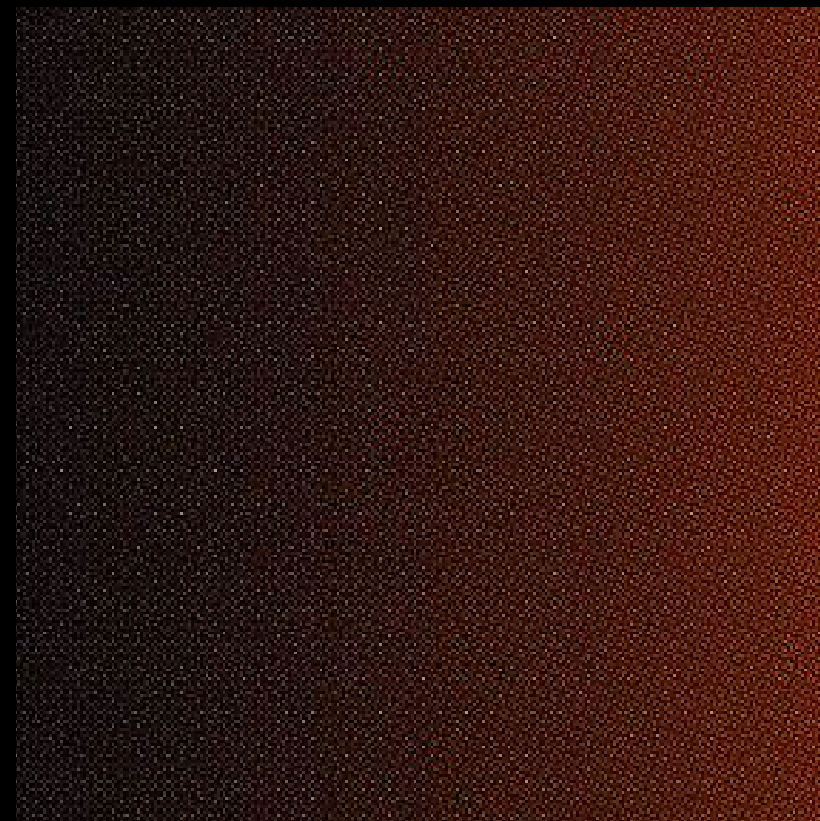
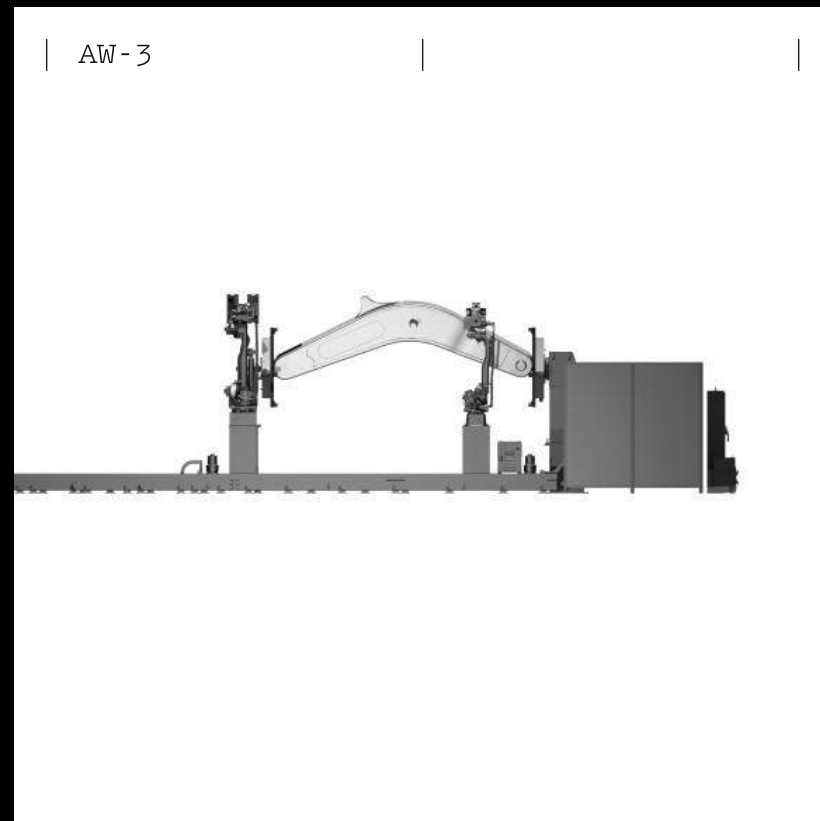

Series C
(Million)

56

100

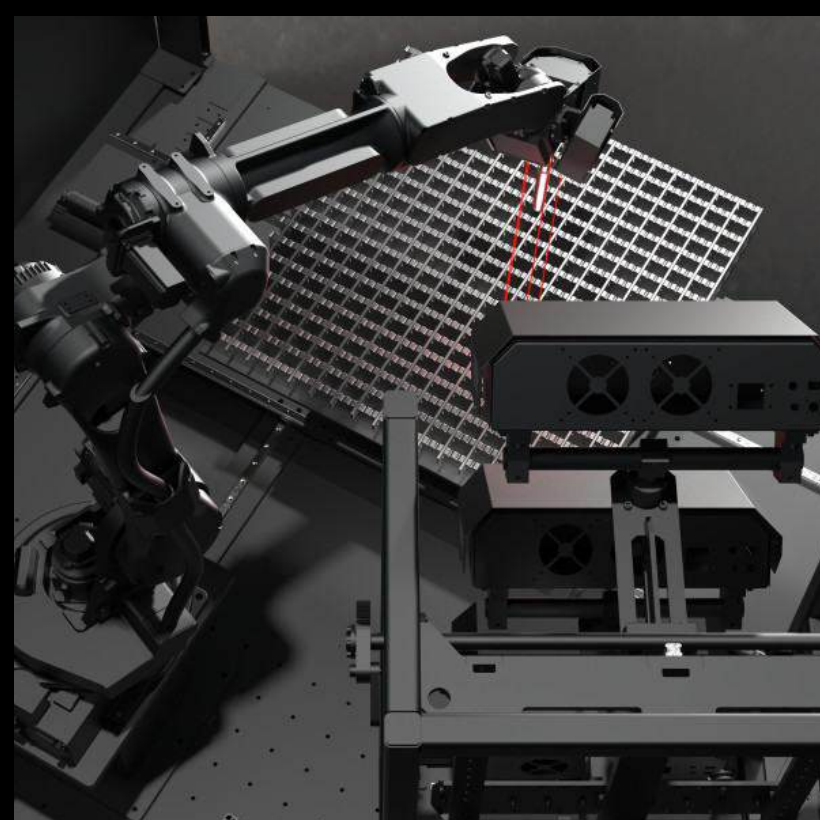

We're
Turning
3

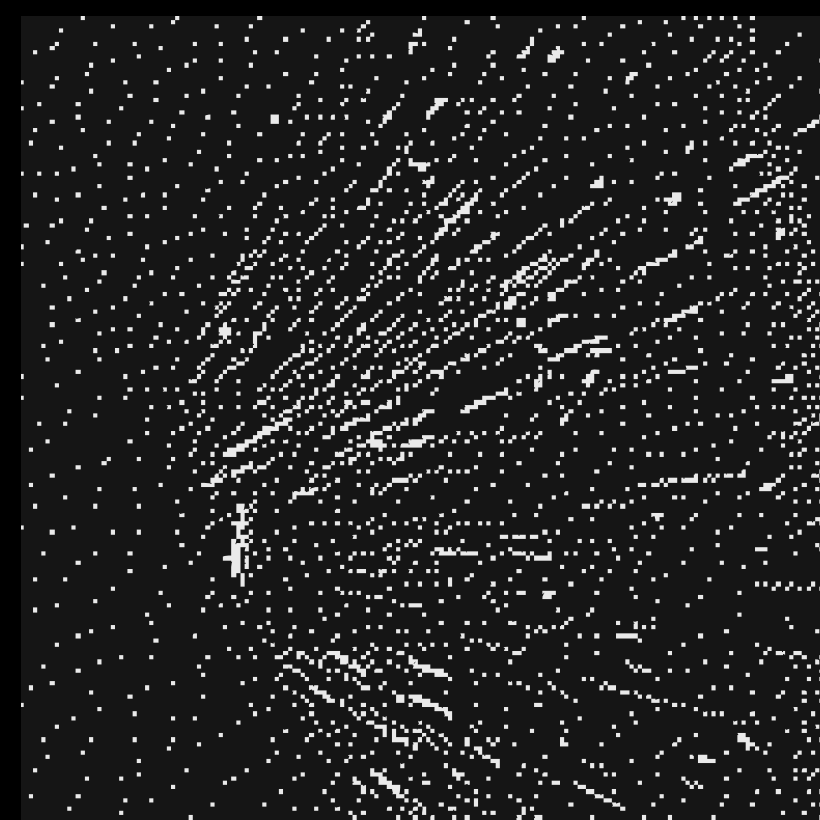



Tim Trad
Creative Director

524 Maier Place,
Columbus, OH 43215

P
E

222.333.4444
TimTrad@pathrobotics.com



See



Understand

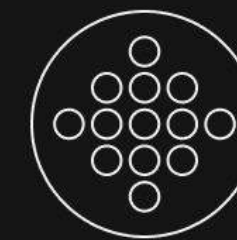

Orient

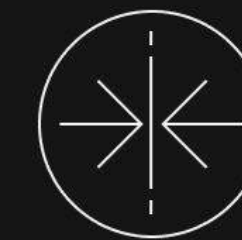

Fit-Up



Weld



ESTHER

Overview

Rum is back. Esther is a premium single-origin Colombian rum that trades pirate motifs for terroir. Now people ask for the green cap bottle they can see from across the bar.

Services

Messaging
Digital Design
Development

Links

Case ↗
Website ↗
The Manifest ↗



CK THIS STORY IS ALWAYS BEGINNING AND NEVER ENDING FOUNDED IN 2025 RUM IS BACK THIS STORY IS ALWAYS BEGINNING AND NEVER ENDING FOUNDED IN 2025 RUM IS

RUM IS BACK

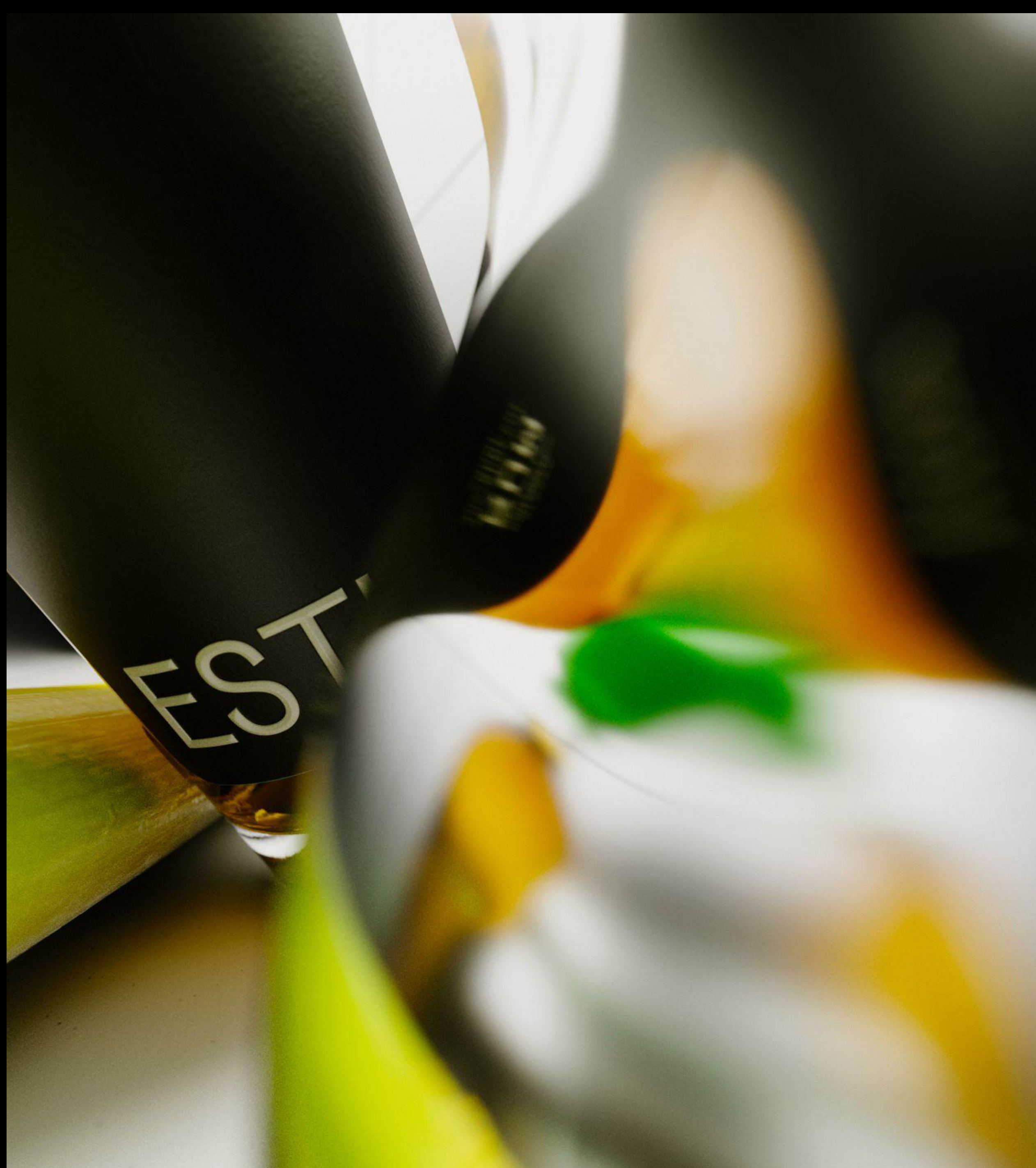

weaving through stone-smooth alleyways, music is always playing here; the waves sing to the rocky shore, a chorus of voices builds and softens on the boardwalk, the foodcart's wooden wheels clatter through the street, life is always blooming here, spring flowers opening and closing, seeds sprouting in wet earth, your hand opening and closing around a glass of Esther in the moonlight as you laugh, as you tell your story, a story that's always beginning and never ending, and here you are. You step into the street, lights glowing in the evening sky, breeze weaving through stone-smooth alleys, waves singing to a rocky shore, voices building and softening on the boardwalk, kettles whistling with boiling water, spices sizzling in a hot metal pan, glasses clinking and filling and emptying as smiles broaden and laughter deepens and you look into the eyes across from yours – they tell you a story with no beginning and no end and you understand and you take a sip and the chorus of voices begins to sing, the stars like small fires dancing in the sky, and you step outside into their bright light, into the story that's always beginning and never ending and here you are. This is grass in the field, the green grass that burns, flames licking the bottom of the sky at the end of the season, this is a season when time unfurls in a smooth ribbon, smooth like jazz, like honey, like hints of honey, of grass, of spice, of depth and of lightness, lightness like how we feel when we are understood, when possibilities present themselves on a silver platter, because after all, this is



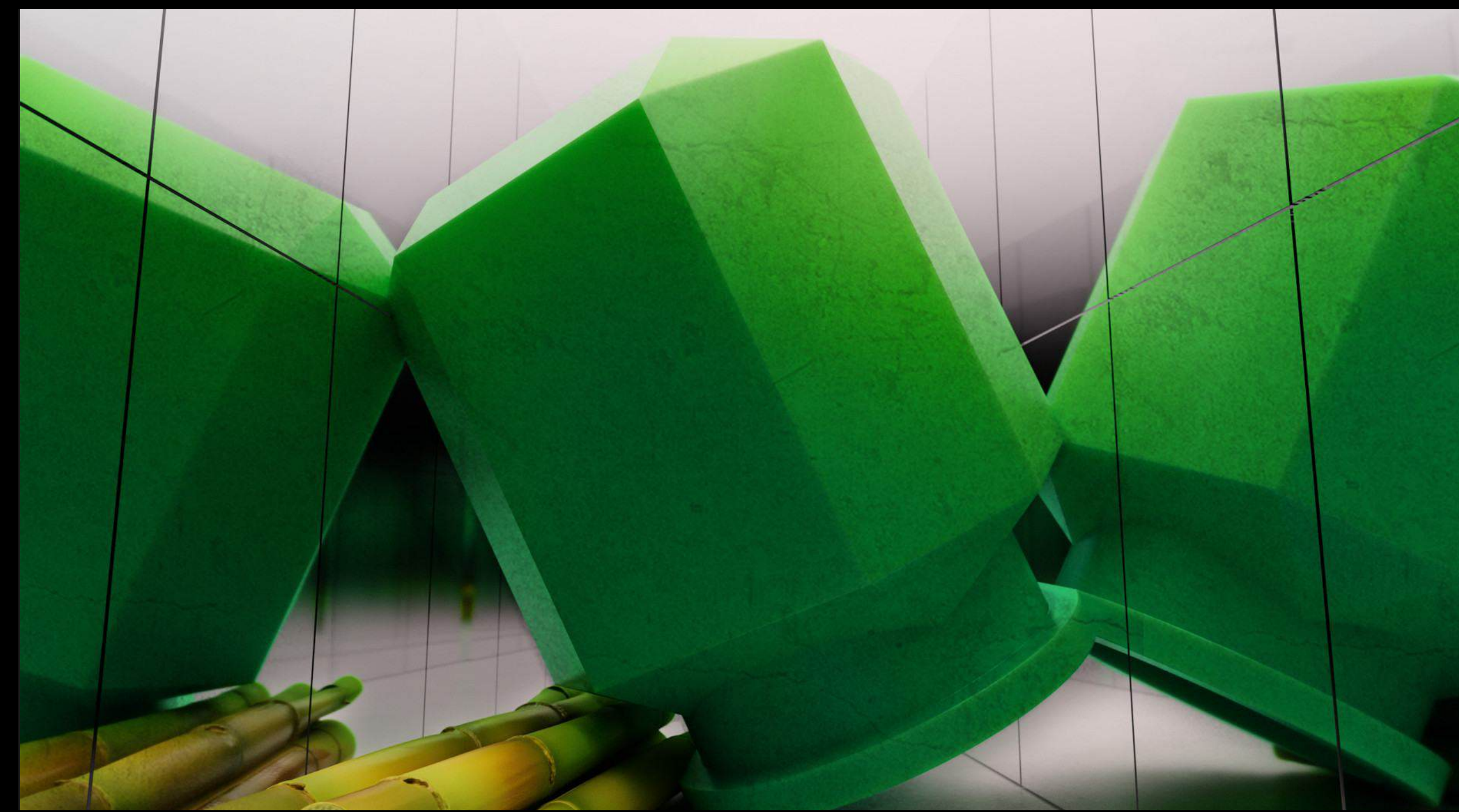

ALWAYS
BEGINNING
NEVER
ENDING
ALWAYS
BEGINNING
NEVER
ENDING



Rum is back.
Esther is a premium Colombian rum made for a new generation of drinkers. It's pure, modern, and full of character. Esther is a signature rum aged up to 4 years.
Esther is elevating the humble sugarcane to its rightful place. A spirit with depth, balance, and simplicity. A modern Colombian rum that shows what rum can be when it's made with intention.
Always beginning, never ending. Esther embraces the wildness of fermentation, the character of place, and the never-ending in you.
This rum has a balanced profile works anywhere to replace the use of gin, tequila, or whiskey for a new kind of flavor experience.



36.99 bottle
ADD TO CART

ESTHER RUM
ESTHER
BACK TO TABLE MENU
CART (0)



COINSHIFT

Overview

Onchain value movement for financial futurists. With Coinshift, onchain payments, accounting, and treasury operations are as straightforward as modern banking.

Services

Strategy

Messaging

Visual Identity

Applied Design

Digital Design

Development

Campaign

The leading smart account for RWAs.

coinshift.xyz



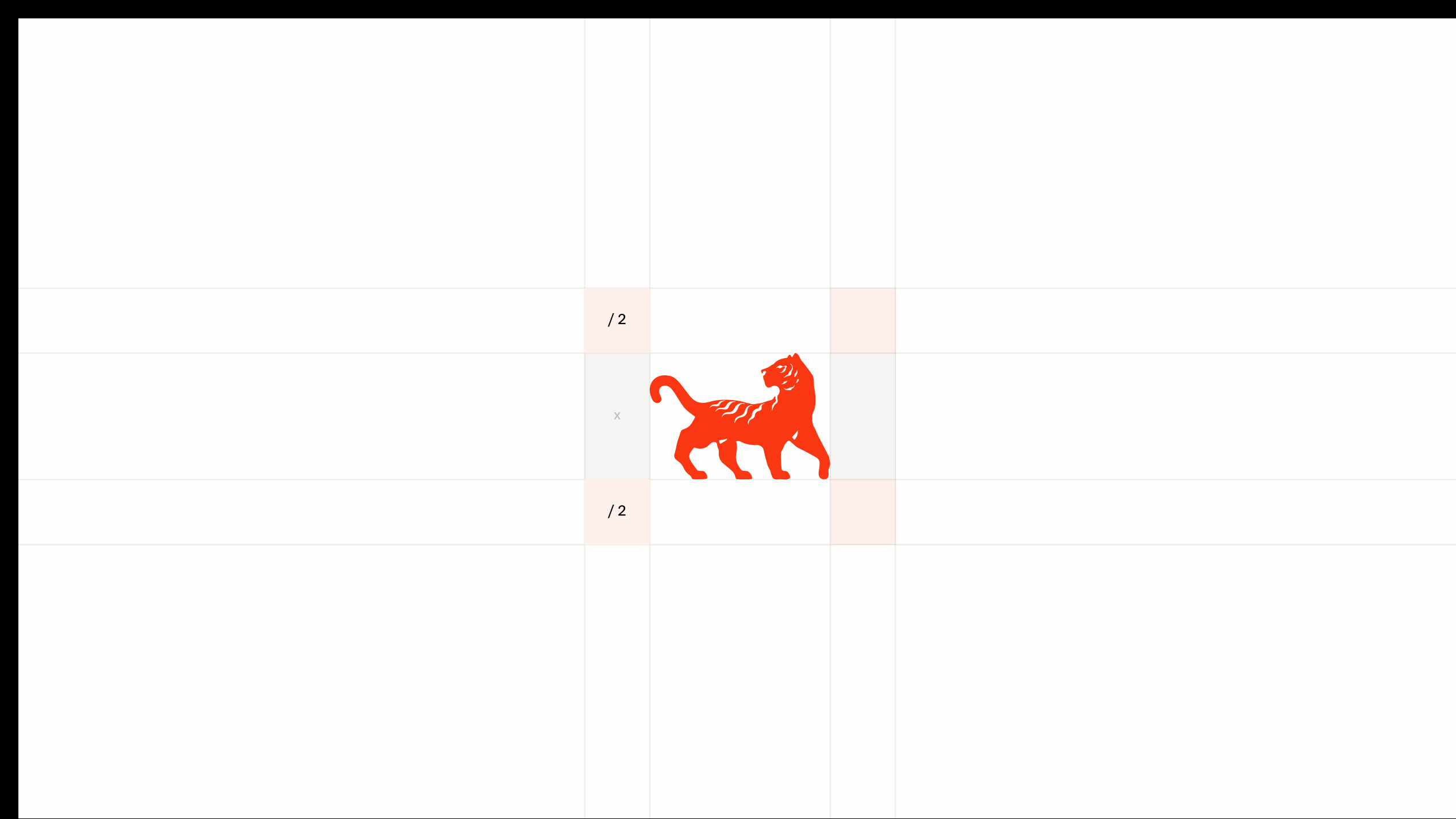

Accelerate
your month-
end close



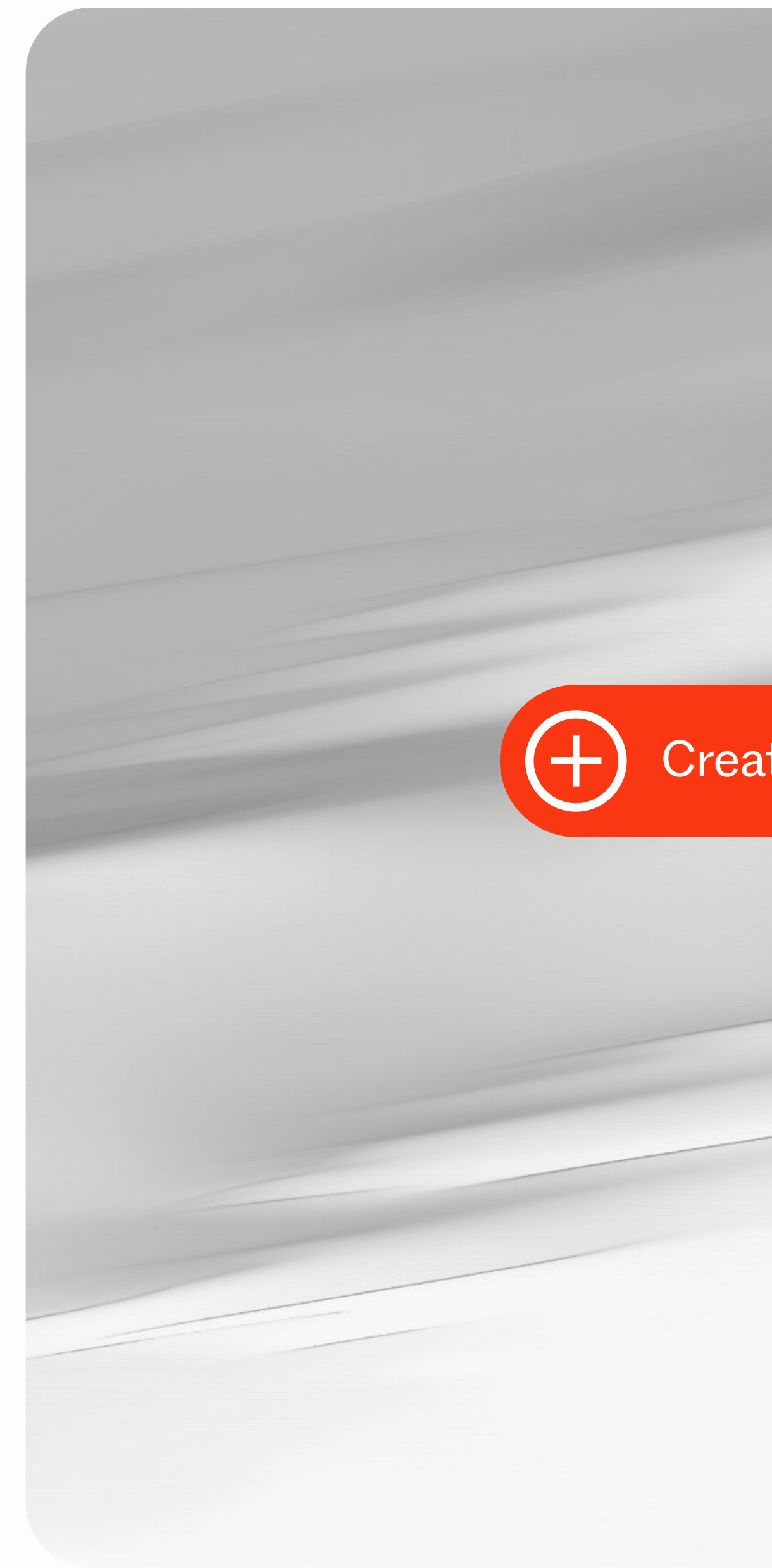
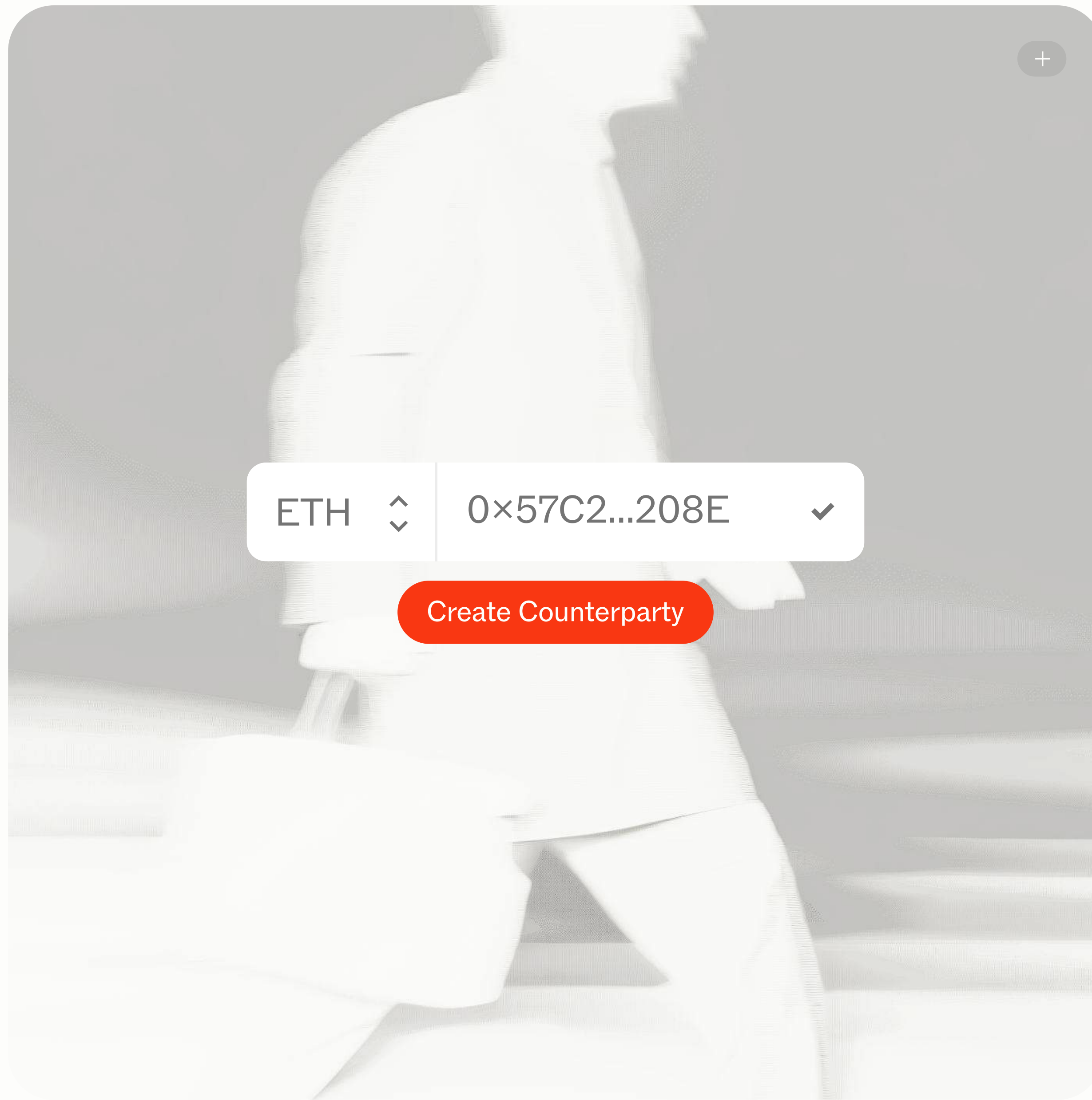
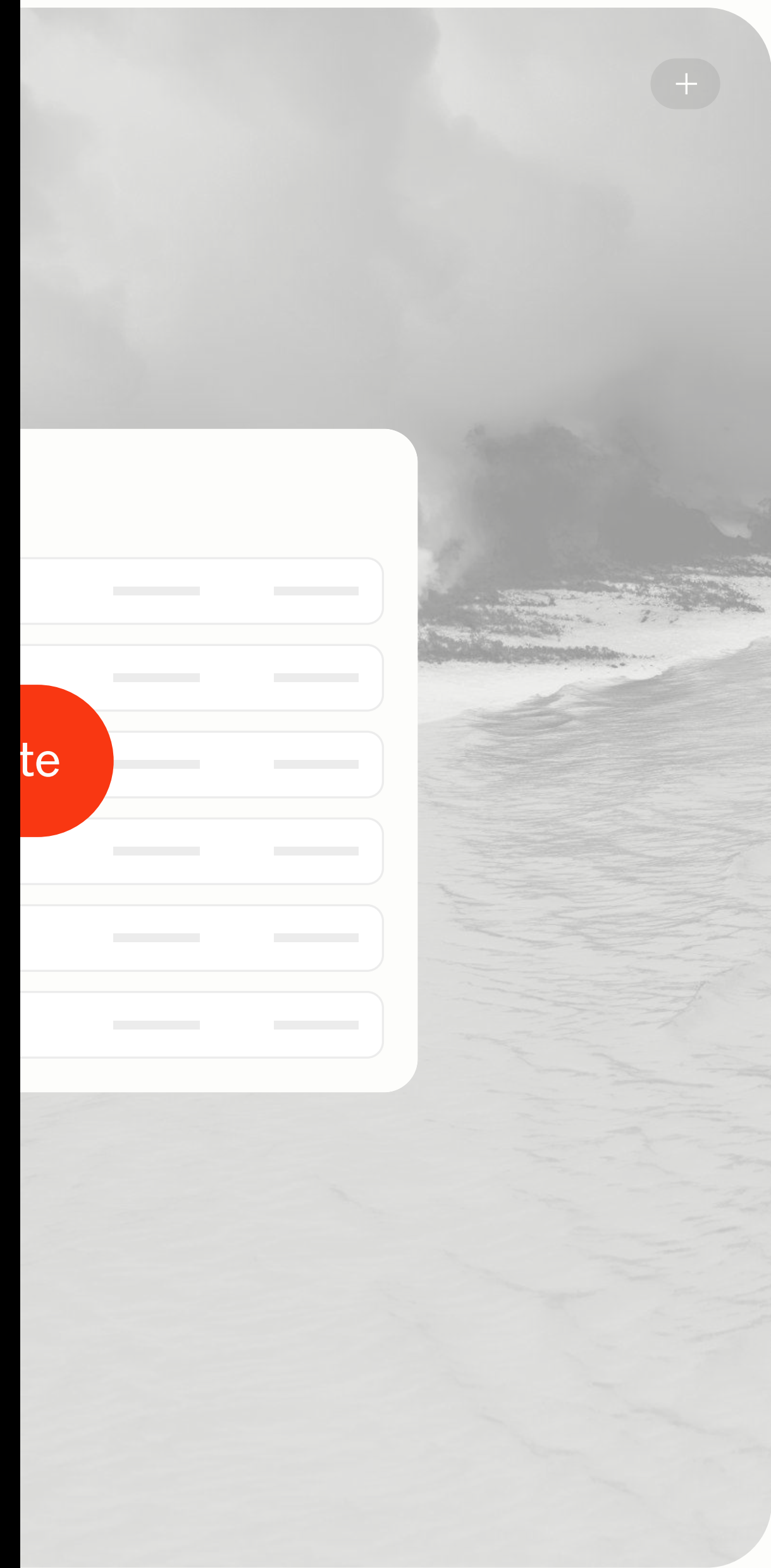



Influence the future

Market trends prove the global economy is moving onchain, demanding a new era of banking. We believe that innovation cannot happen in isolation. Web3 industry leaders will be responsible for bridging the divide, and opening access and adoption. Apply to be a Founding Member and help us shape the future of onchain banking.

Apply to be a Founder →



Founding Members

Ryan Hoover, Product Hunt →

Shi Khai, Long Hash Capital →



BAD BOYS

Overview

We ride together. We die together. To celebrate the 25th Anniversary of the “Bad Boys” franchise, Will Smith’s family media company needed to do an unmissable merch capsule drop.

Services

Messaging
Creative Direction
Digital Design
Development
Campaign

Links

Case ↗
Website ↗
Awwwards ↗
Complex ↗

WE RIDE TOGETHER.
WE DIE TOGETHER.

[SHOP](#)

[INFO](#)

[FAQ](#)

[GALLERY](#)

[CART \(0 ITEMS\)](#)

OFFICIAL BAD BOYS
MOVIE MERCH STORE



BAD BOYS

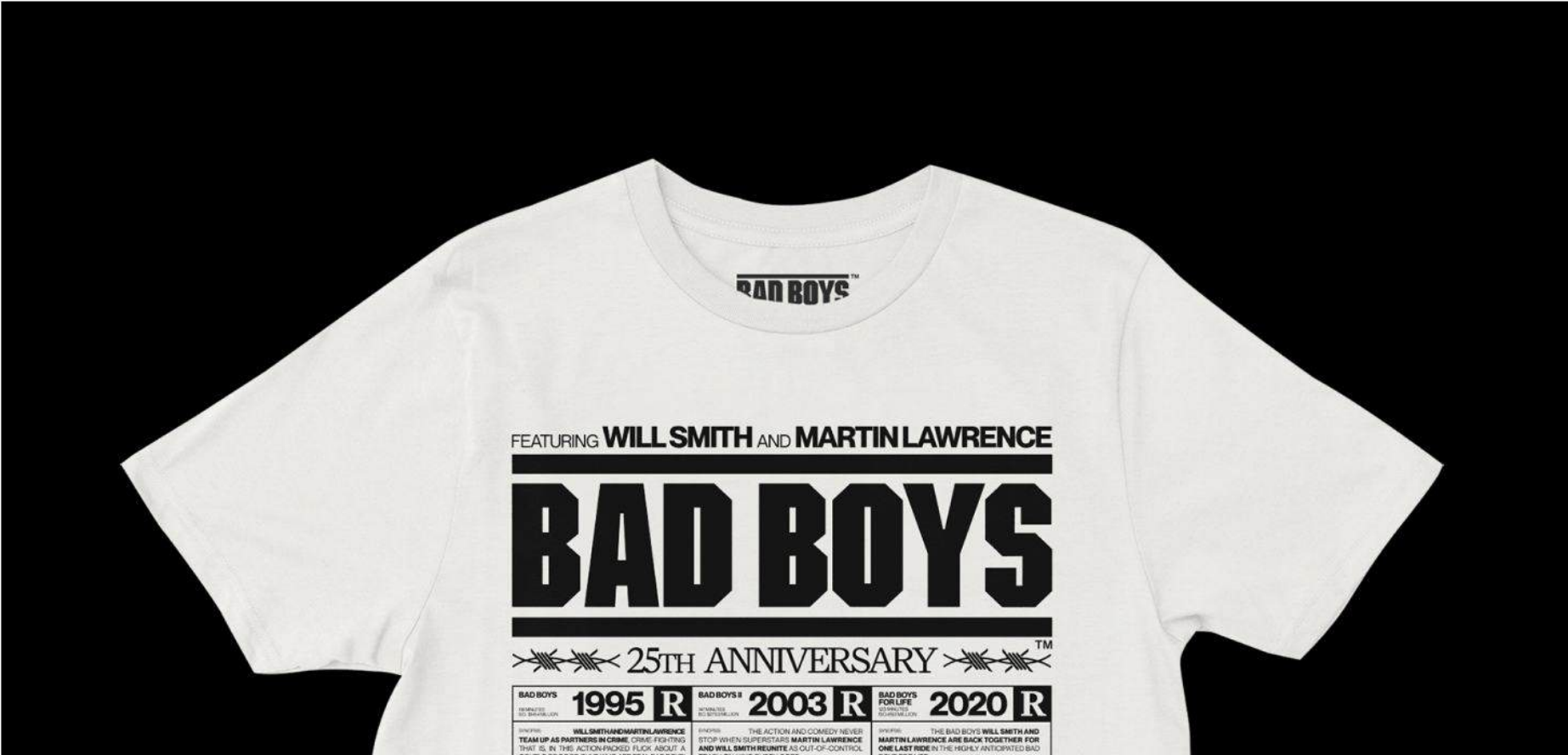





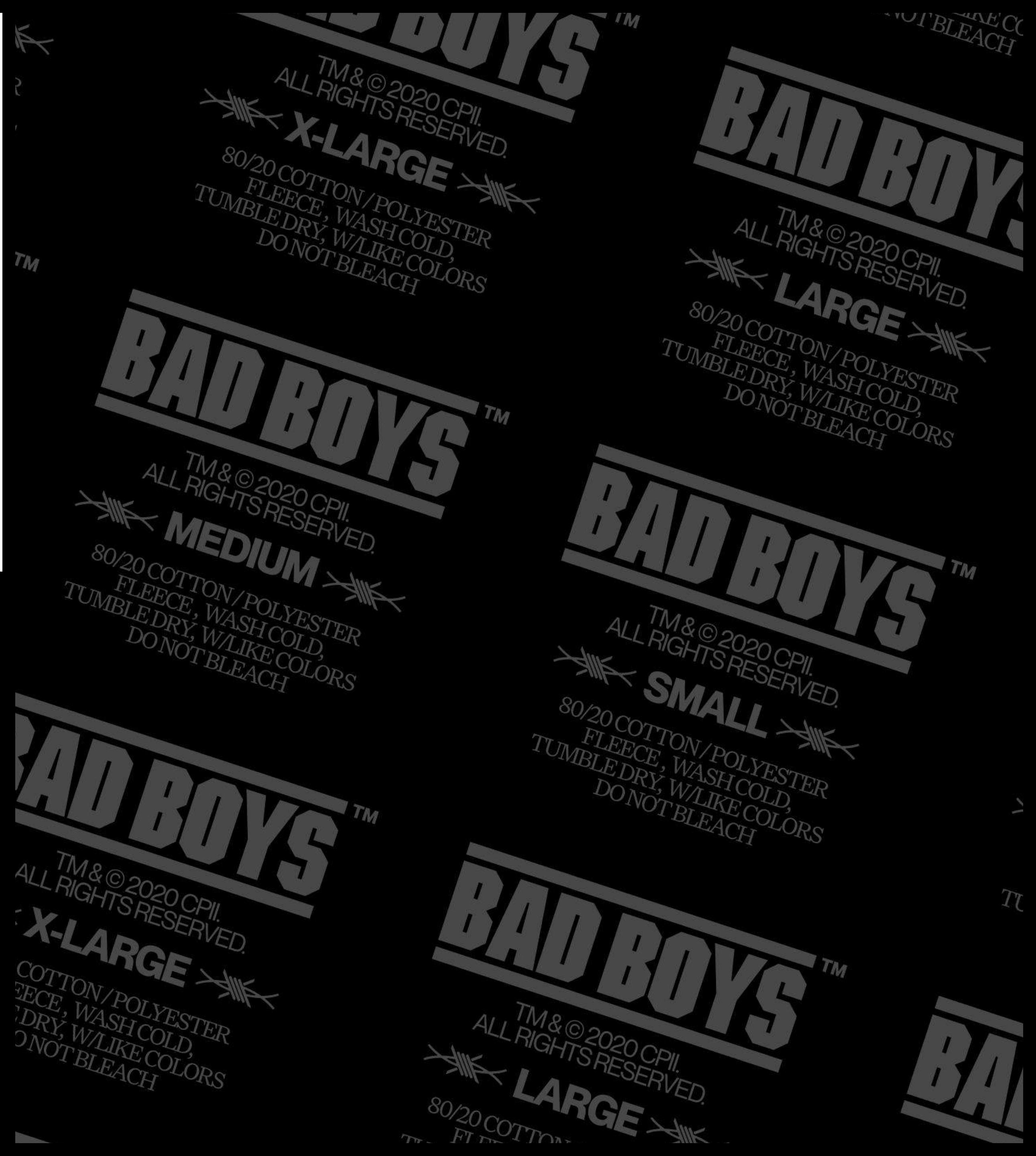
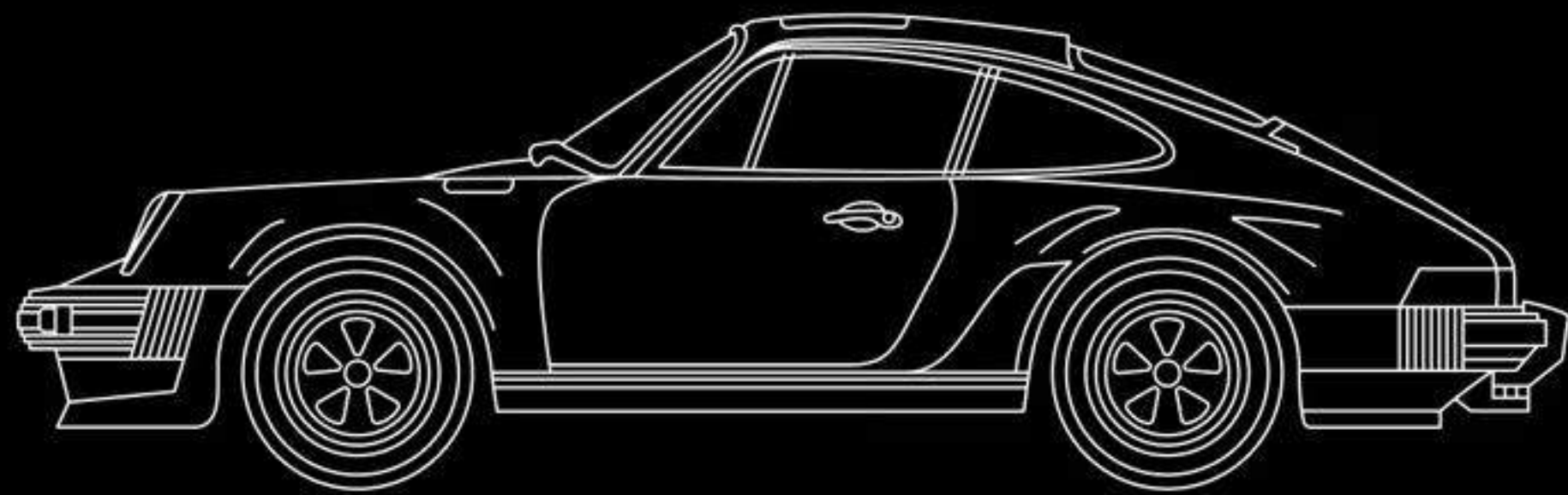
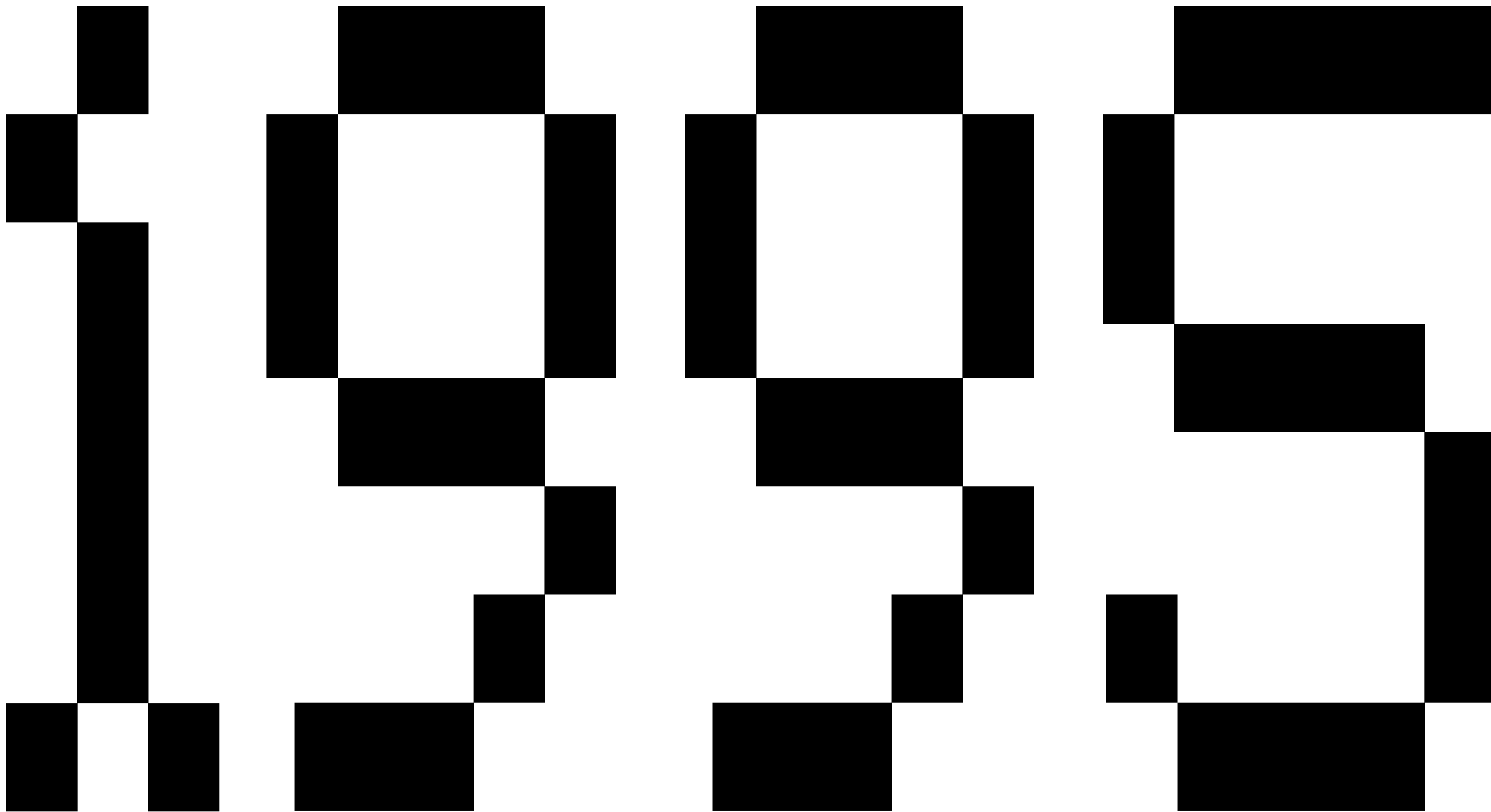



BB QUOTE HOODIE

\$65.00

STYLE: BLACK



SIZE: LARGE

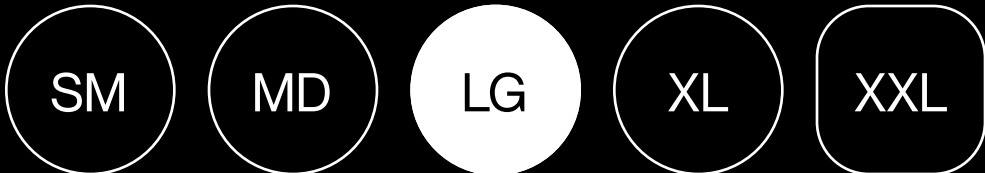

What's a Bad Boys movie without a solid quote from Cap? No clue. Doesn't exist. Honor Cap and the 25th Anniversary of Bad Boys with this limited edition drawstring hoodie. Available in black and light grey for 10 days only.

This is a limited edition production run. Printing starts when the drop ends. Reminder: Bad Boys For Life. Shipping may take 10+ days due to COVID-19.



This **DECK** of previews has ended but we'd love to get a conversation started.

Contact

hello@studiofreight.com
studiofreight.com

WORK
WITH
US

