

Technical Manual

komet | *Trigon*

Trigon 105

Trigon 112

Operating instructions

Gebrauchsanweisung
Istruzioni d'uso
Instructions d'utilisation
Instrucciones de uso
Instruções de utilização
Gebruikers instructies
Betjeningsvejledning
Handhavande instruktioner
Brukerveiledning
Руководство по эксплуатации
Kezelési útmutató
Οδηγίες λειτουργίας

Spare parts

Ersatzteile
Ricambi
Pièces de rechange
Piezas de recambio
Peças de reposição
Onderdelen
Reservedele
Reservdelar
Reservedeler
Запасные части
Alkatrészek
Ανταλλακτικά

Trouble shooting

Fehlersuche
Ricerca guasti
Recherche des pannes
Busca de los desperfectos
Identificação de defeitos
Probleem oplossing
Problemlösning
Felsökning
Feilsøking
Диагностика неисправностей
Hibakeresés
Οδηγίες επίλυσης προβλημάτων

Service instructions

Service Anleitungen
Istruzioni di servizio
Instructions de service
Instrucciones de servicio
Instruções de serviço
Service instructies
Vedligeholdelsesinstruktioner
Service instruktioner
Serviceveiledning
Руководство по техническому обслуживанию
Szerviz útmutató
Οδηγίες συντηρησης



English, Deutsch, Italiano, Français, Español, Português,
Nederlands, Dansk, Svenska, Norsk, Русский, Magyar, Ελληνικά

THE KOMET ADVANTAGE:
INNOVATION WITH IMPACT

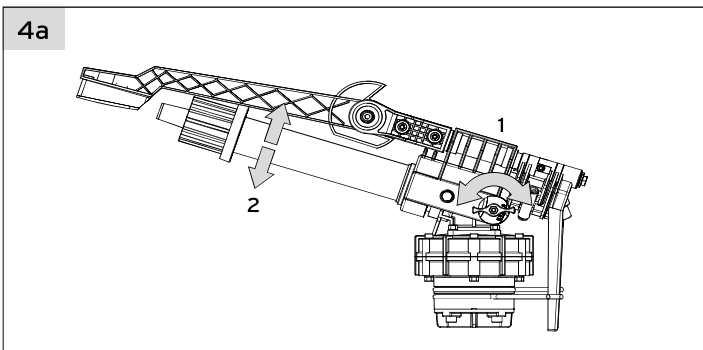
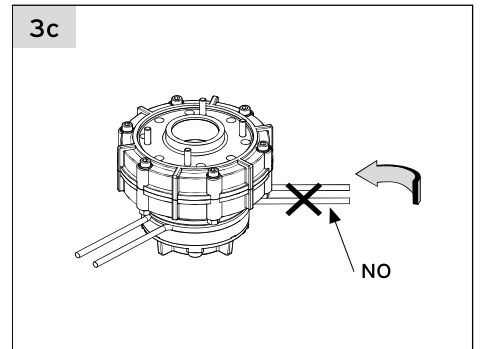
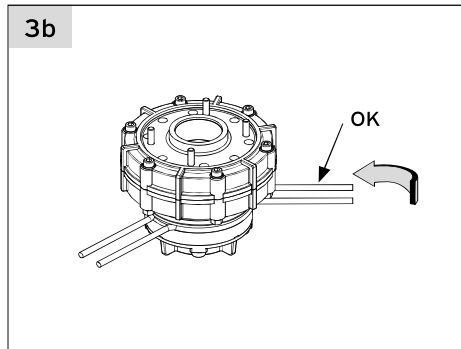
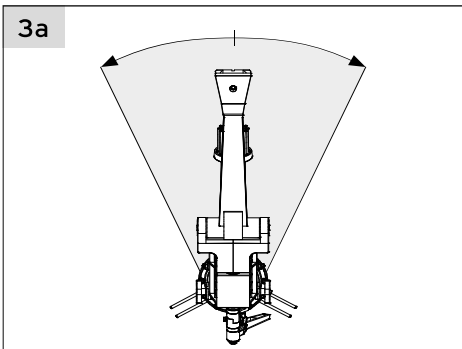
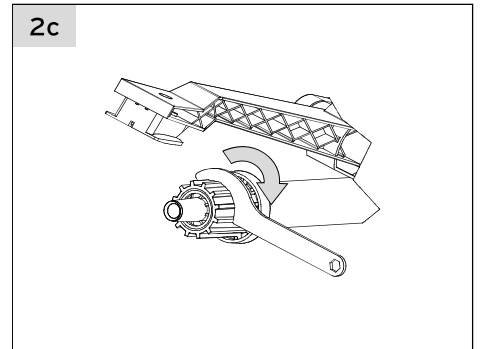
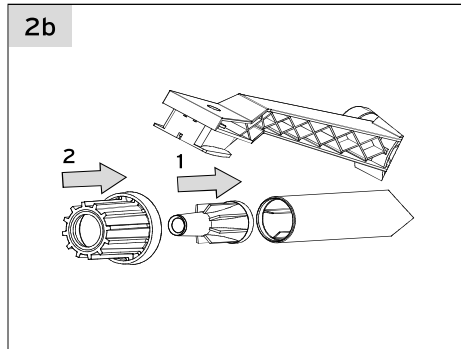
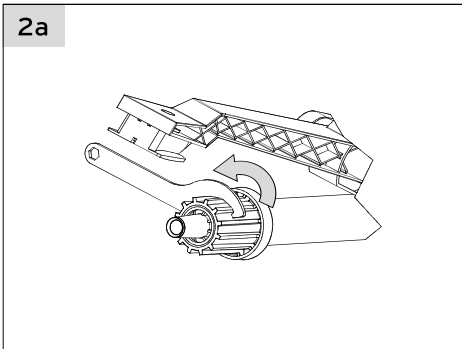
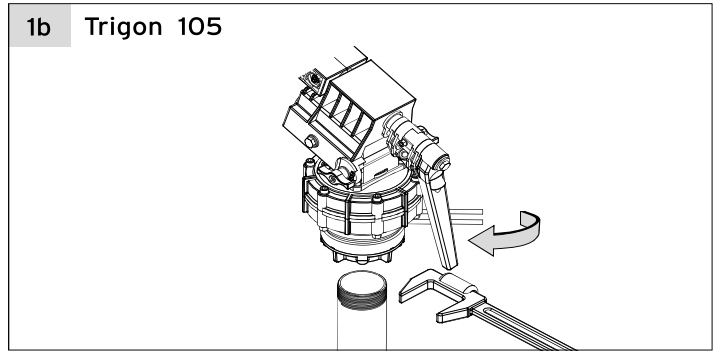
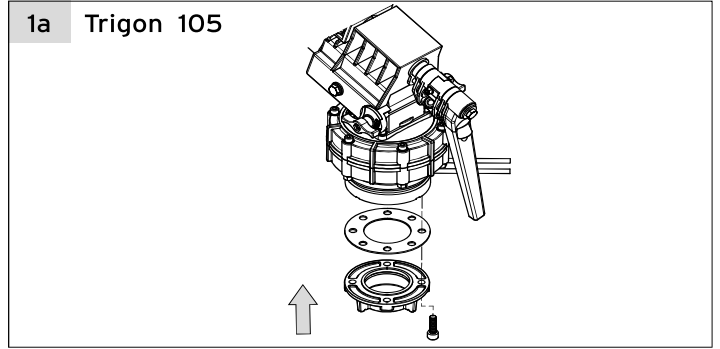
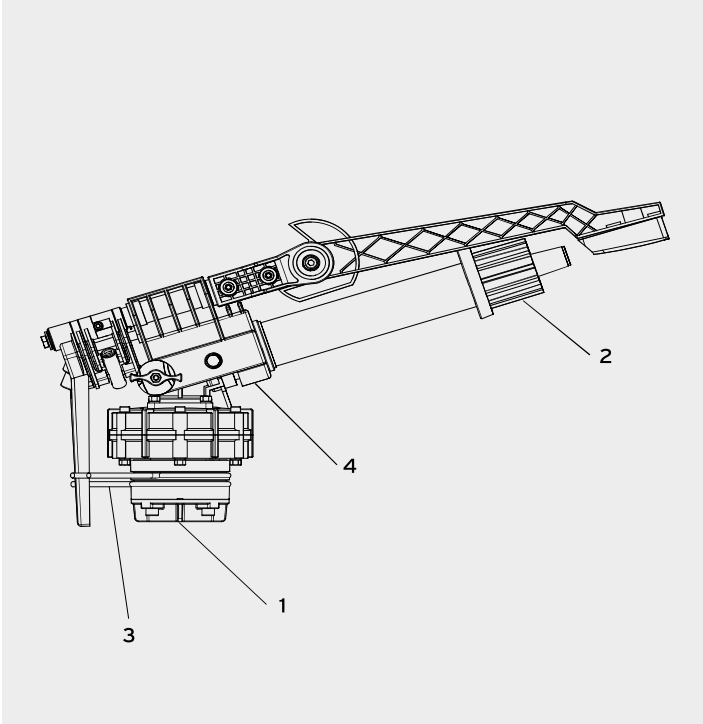

IMPORTANT

These instructions must be given to the operator. Before operating the TRIGON big volume sprinkler, read these instructions carefully. Keep instructions for future reference.



DANGER

- Do not perform any adjustments or controls while the sprinkler is in operation.
- Stand clear of the action area of the sprinkler.
- Stand clear of the high pressure water jet.
- Insure water jet is not directed toward people, powerlines, roads, buildings or any other objects.
- Before operating the sprinkler, insure no people are standing in its action area.

START-UP PROCEDURES

(refer to drawings)

1. Mounting the sprinkler:

Mount the threaded adaptor on the sprinkler base by securely attaching the bolts provided (Trigon 105). Then screw the sprinkler onto its stand and tighten it securely with a wrench.

2. Nozzle:

Replace nozzle with desired one. Before retightening the nozzle cap, be sure the nozzle is properly fit into the barrel to avoid damage of the barrel and of the nozzle. Tighten the nozzle cap securely.

Important: Nozzles should be handled carefully. They should not be stored in a tool box or strung on a wire or rope to prevent damage.

3. Part circle operation:

To set the desired part circle, bring the trip stop rings into position by pulling each of them at one end only or by pushing on one end from the inside.

Do not push on the ends from the outside as the rings will block.

4. Vari Angle system:

Loosen the locking nuts, then set the desired trajectory. Retighten the locking nuts.

PERIODIC CONTROLS:

- All moving parts must move freely.
- Check deflector blade for damage, replace if necessary.
- Check nozzle. A damaged nozzle may result in a not round and compact jet which could cause malfunction of the sprinkler.
- A malfunctioning sprinkler due to repeated tip over's of the sprinkler mount should be inspected by your dealer.

Gebrauchsanweisung

Deutsch

WICHTIG

Diese Gebrauchsanweisung muss dem Bediener ausgehändigt werden. Vor Inbetriebnahme des TRIGON Regners diese Anleitung aufmerksam lesen. Die Gebrauchsanweisung ist aufzubewahren.



GEFAHR

- Niemals Einstellungen oder Kontrollen am funktionierenden Regner ausführen.
- Sich nicht im Arbeitsbereich des Regners aufhalten.
- Sich nicht in die Wurfparabel des Hochdruckstrahles stellen.
- Den Wasserstrahl nicht auf Personen, elektrische Leitungen, Straßen, Gebäude oder andere Gegenstände richten.
- Bevor der Regner unter Druck gesetzt wird, sich vergewissern, dass sich niemand in seinem Arbeitsbereich aufhält.

INBETRIEBNAHME

(siehe Zeichnungen)

1. Aufsetzen des Regners:

Gewindeanschluss, mit Schrauben auf den Regnersockel aufbauen, Schrauben sorgfältig anziehen (Trigon 105). Dann den Regner auf das Standrohr schrauben und mit einer Rohrzanze fest anziehen.

2. Düse:

Gewünschte Düse wählen und austauschen. Vor dem Anziehen der Überwurfmutter darauf achten, dass die Düse richtig im Strahlrohr sitzt, um Schäden sowohl am Strahlrohr als auch an der Düse zu vermeiden.

Wichtig: Düsen sorgfältig hantieren und aufbewahren. Die Düsen nicht mit einem Spagat oder Draht aufhängen, da sie sonst beschädigt werden.

3. Sektorberegnung:

Sektorenringe einzeln an einem Bügelende, in die gewünschte Position ziehen oder die Sektorenringe an einem Bügelende von innen schieben. Die Bügelenden nicht von außen schieben, da sie sonst verklemmen.

4. Vari-Angle System:

Arretiermuttern lösen, den gewünschten Strahlneigungswinkel einstellen. Arretiermuttern wieder sorgfältig anziehen.

PERIODISCHE KONTROLLEN:

- Alle beweglichen Teile müssen leichtgängig sein.
- Ablenker auf Beschädigung prüfen, gegebenenfalls austauschen.
- Düse auf Beschädigung prüfen. Ein nicht gebündelter, kompakter Strahl kann Ursache für Funktionsstörungen sein.
- Bei Funktionsstörungen die durch wiederholtes Umkippen des Regnerstandes hervorgerufen wurden, den Regner vom Händler kontrollieren lassen.

Istruzioni d'uso

Italiano

IMPORTANTE

Queste istruzioni devono essere consegnate all'operatore. Prima di mettere in funzione l'irrigatore TRIGON leggere attentamente queste istruzioni e quindi conservarle con cura.



PERICOLO

- Non eseguire mai regolazioni e controlli sull'irrigatore in funzione.
- Non sostare nel raggio d'azione dell'irrigatore.
- Non sostare nella parabola di lancio del getto ad alta pressione.
- Non dirigere il getto d'acqua su persone, linee elettriche, strade, edifici ed altri oggetti.
- Prima di mettere sotto pressione l'irrigatore, accertarsi che non vi siano persone nel suo raggio d'azione.

OPERAZIONI PRELIMINARI

(vedi disegni)

1. Montaggio dell'irrigatore:

Montare l'attacco filettato sulla base dell'irrigatore fissandolo bene con le viti in dotazione (Trigon 105). Avvitare poi l'irrigatore sul suo supporto fissandolo bene con un giratubi.

2. Boccaglio:

Sostituire il boccaglio con quello desiderato. Prima di riavvitare il bocchettone, assicurarsi che il boccaglio sia alloggiato correttamente nella sua sede nel tubo, altrimenti possono essere danneggiati sia il tubo che anche il boccaglio.

Importante: maneggiare con cura i boccagli. Non appenderli mai con fili di ferro o spago. Essi vengono danneggiati e possono essere causa di malfunzionamento dell'irrigatore.

3. Irrigazione a settore:

Regolare l'ampiezza settore tirando gli anelli arresto settore dall'esterno oppure spingendo sui gambi dall'interno portandoli nella posizione desiderata. Non

spingere gli anelli dall'esterno, si bloccano e possono essere danneggiati.

4. Sistema Vari-Angle:

Allentare i dadi di bloccaggio. Impostare l'angolo di traiettoria desiderato, quindi risserrare bene i dadi di bloccaggio.

CONTROLLI PERIODICI:

- Tutti i movimenti devono essere liberi.
- Controllare il deviatore, se danneggiato sostituirlo.
- Controllare il boccaglio. Un boccaglio danneggiato non produce un getto rotondo e compatto e può essere causa di malfunzionamento dell'irrigatore.
- Se ripetuti rovesciamenti del supporto causano un malfunzionamento dell'irrigatore, farlo controllare dal vostro rivenditore.

IMPORTANT

Ces instructions doivent être remises à l'opérateur. Bien lire ces instructions avant de mettre l'arroseur TRIGON en service et les conserver soigneusement.



DANGER

- Ne pas faire de réglages ou contrôles sur l'arroseur en marche.
- Stationner hors du rayon d'action du canon.
- Stationner hors de la portée du jet d'eau sous haute pression.
- S'assurer que le jet d'eau ne soit pas dirigé sur des personnes, lignes électriques, voies publiques, bâtiments et autres objets.
- Avant de mettre en marche, s'assurer que personne ne stationne dans le rayon d'action du canon.

INSTRUCTIONS DE MISE EN SERVICE

(voir croquis)

1. Montage du canon d'arrosage:

Monter le raccord fileté sur la base du canon à l'aide des vis en dotation (Trigon 105) puis fixer le canon à son support. Bien resserrer les vis.

2. Buse:

Monter la buse désirée. Avant de fixer la goulotte, s'assurer que la buse soit correctement placée dans le fût pour éviter d'endommager fût et buse. Bien serrer la goulotte.

Important: les buses doivent être manipulées avec précaution. Celles de réserve ne doivent pas être suspendues à une ficelle, car elles pourraient être endommagées et causer des ennuis de fonctionnement.

3. Arrosage à secteur:

Pour régler l'ampleur du secteur, déplacer les anneaux secteur dans la position voulue en poussant ou en tirant de l'intérieur sur une seule tige à la fois. Ne pas pousser sur les tiges de l'extérieur, les anneaux se bloqueraient.

4. Dispositif Vari-Angle:

Desserrer les écrous de blocage et imposer l'angle de trajectoire voulu. Resserrer les écrous de blocage.

CONTRÔLES PÉRIODIQUES:

- Toutes les parties mobiles doivent se mouvoir librement.
- Contrôler l'intégrité du déflecteur, le remplacer si nécessaire.
- Contrôler la buse. Une buse endommagée pourrait compromettre la compacité du jet et causer des ennuis de fonctionnement.
- Si les ennuis de fonctionnement sont dus à des chutes répétées du support du canon, demander l'intervention de votre revendeur.

IMPORTANTE

Estas instrucciones deben ser entregadas al usuario. Antes de poner en marcha el aspersor TRIGON, leer atentamente estas instrucciones y guardarlas para el futuro.



PELIGRO

- No realizar ningún control o reajuste mientras el aspersor está trabajando.
- No permanecer en el área de acción del aspersor.
- No permanecer en el área del chorro a alta presión.
- Compruebe que el chorro de agua no pueda llegar a personas, líneas eléctricas, carreteras, edificios o cualquier otro objeto.
- Antes de poner en funcionamiento el aspersor, asegurarse de que ninguna persona este en su radio de acción.

PROCESO PRELIMINAR

(ver dibujo)

1. Montaje del aspersor:

Fijar bien la rosca en la base del aspersor con los tornillos de seguridad facilitados (Trigon 105), después atornillar el aspersor en su soporte y apretarlo fuertemente con una llave gira-tubos.

2. Boquilla:

Sustituir la boquilla con otra del tamaño seleccionado. Antes de volver a apretarla, asegurarse que está correctamente alojada en la base del tubo, para evitar cualquier daño en el tubo y la boquilla. Apretar fuerte.

Importante: manipular cuidadosamente la boquilla. No utilizar nunca alambres o cuerdas. Esto puede dañar y puede averiar el aspersor.

3. Aspersión sectorial:

Regular la amplitud del sector tirando del anillo freno sector, apretando desde la parte interna de las patillas y posicionarlo en el lugar deseado. No empujar desde la parte externa, los anillos podrían bloquearse.

4. Sistema Vari-Angle:

Aflojar las tuercas de cierre, después fijar el ángulo de trayectoria deseado. Volver a apretar bien las tuercas de cierre.

CONTROLES PERIODICOS:

- Todas las partes móviles deben estar libres.
- Comprobar el deflector, si está averiado sustituirlo.
- Comprobar la boquilla. Una boquilla defectuosa no proporciona un chorro redondo ni compacto, y puede ser causa de un mal funcionamiento del aspersor.
- Si el soporte aspersor vuelca repetidamente, causa un mal funcionamiento del aspersor. Hacer una revisión con el suministrador.

IMPORTANTE

Estas instruções devem ser dadas para o operador. Antes de colocar o canhão TWIN em operação, leia cuidadosamente estas instruções e guarde-as para referência futura



PERIGO

1. Não realizar quaisquer ajustes ou controle com o canhão em operação.
2. Afaste-se da área de operação do canhão.
3. Não fique na área do jato de água de alta pressão.
4. Certifique-se que o jato de água não seja dirigido a pessoas, rede elétrica, estradas, prédios ou quaisquer outros objetos.
5. Antes de acionar o canhão, certifique-se que não há pessoas na área de operação.

COMO COLOCAR EM OPERAÇÃO

(veja desenhos)

1. Montagem do canhão:

Fixar bem a rosca à base do canhão, usando os parafusos fornecidos (Trigon 105), depois parafusá-lo sobre o seu suporte e aperte bem com uma chave.

2. Bocal:

Substituir pelo bocal desejado. Antes de rosquear, certifique-se que o bocal esteja corretamente encaixado no tubo do canhão, para evitar qualquer dano ao bocal ou tubo. Aperte bem a rosca do bocal.

Importante: Os bocais devem ser manuseados com cuidado. Nunca armazená-los em caixa de ferramenta ou amarrá-los em fios ou cabos, isto poderá danificá-los.

3. Irrigação setorial:

Para regular a amplitude do setor de irrigação, coloque os anéis setor na posição desejada puxando para fora uma só das alavancas dos anéis ou empurrando-a do lado interno. Não empurre-a do lado externo, pois os anéis ficariam bloqueados.

4. Sistema Vari-Angulo:

Desaperte as porcas de bloqueio e ajuste o ângulo de trajetória desejado. Reaperte bem as porcas de bloqueio.

MANUTENÇÃO PERIÓDICA:

- Todas as partes móveis devem girar livremente.
- Verifique o defletor, substitua-o se necessário.
- Verifique o bocal. Um bocal desgastado pode resultar em um jato não redondo e compacto, o qual pode causar mau funcionamento do canhão.
- Um mau funcionamento do canhão devido a repetidas inclinações do suporte do canhão deve ser inspecionado pelo seu distribuidor.

BELANGRIJK

Deze instructies dienen in het bezit te zijn van de gebruiker. Voor het in gebruik nemen van de TRIGON hoog volume sproeier, eerst deze instructies zorgvuldig doornemen. Bewaar deze instructies voor toekomstig gebruik.

**GEVAAR**

- Voer geen werkzaamheden of controles uit terwijl de sproeier in werking is.
- Blijf uit het gebied waar de sproeier werkzaam is.
- Pas op met de hogedruk waterstraal.
- Zorg ervoor dat de waterstraal niet gericht is op personen, elektriciteitslijnen, wegen gebouwen of andere objecten.
- Hou er rekening mee dat er voor het in gebruik nemen van de sproeier geen personen in het straalgebied aanwezig zijn.

START PROCEDURE

(Zie Tekeningen)

1. Montage van de sproeier:

De sproeier is voorzien van een flens (Trigon 105). Gebruik de bijgesloten pakking en bouten om de sproeier zo nauwkeurig mogelijk op te monteren. Draai de bouten overhoeks stevig aan.

2. Sproeimond:

Om een sproeimond te wisselen dient u de speciale bijgesloten sleutel te gebruiken, voordat u de sproeimond bevestigt, dient u er zeker van te kunnen zijn dat de sproeimond goed in het gat past om schade van het gat of de sproeimond te voorkomen. Schade deze goed aan d.m.v de bijgesloten sleutel.

Belangrijk: U dient voorzichtig met de sproeimonden om te gaan.

3. Sector instelling:

Om de gewenste sector in te stellen, zet de sectorringen in de juiste positie d.m.v. het trekken aan de binnenzijde van de sector-ring. Duw niet tegen de buitenkant van de sector-ring, de sector-ring zal dan blokkeren.

4. Variabele hoekinstelling Vari-Angle System:

D.m.v. het gebruik van een sleutel kunt u de wenste hoek instellen.

REGELMATIGE CONTROLES:

- Alle bewegende onderdelen moeten vrij kunnen bewegen.
- Controleer de straalbreker op schade, indien nodig vervangen.
- Controleer de sproeimond. Een beschadigde sproeimond kan een slechte of kleine straal veroorzaken welke zou kunnen leiden tot het slecht functioneren van de sproeier.
- Een sproeier welke slecht functioneert dient nagekeken te worden door uw dealer.

Betjeningsvejledning

Dansk

VIGTIGT

Disse instruktioner skal gives til brugeren. Før TRIGON sprederen tages i brug skal denne betjeningsvejledning læses grundigt. Gem betjeningsvejledningen til fremtidig brug.

**ADVARSEL**

- Udfør ikke nogen kontrol eller justeringer når sprederen er i drift.
- Bliv uden for spredersens arbejdsområde.
- Pas på vandstrålen med højt tryk.
- Vær sikker på, at vandstrålen ikke har retning mod personer, højspændingsledninger, veje, bygninger eller andre genstande.
- Før sprederen sættes i drift må det sikres, at der ikke er andre personer i dens arbejdsområde.

OPSTARTSPROCEDURE

(ref. til tegninger)

1. Montering af sprederen:

Hvis sprederen er udstyret med en flange, bruges vedlagte pakning og bolte til at fastgøre den sikkert. Spænd boltene omhyggeligt (Trigon 105). Hvis sprederen er udstyret med gevind, påskrues og spændes den omhyggeligt med en nøgle.

2. Dyser:

Før at skifte dyse bruges den vedlagte specialnøgle. Før dysen spændes må det sikres, at dysen sidder rigtigt i spredersens rør for at undgå beskadigelse af sprederen og dysen. Spænd omhyggeligt med specialnøglen. **Vigtigt:** Dyserne skal behandles forsigtigt. De må ikke opbevares i en værktøjskasse eller hænges op på ståltråd og snore, da dette vil ødelægge dem.

3. Sektorvanding:

Før at justere den ønskede sektorvinkel bringes stopanslagene i position ved at skubbe dem fra

indersiden. Skub ikke fra ydersiden, da ringene derved låses.

4. Vari-Angle system:

Låsemøtrikken løsnes og den ønskede hældningsvinkel indstilles. Spænd låsemøtrikken igen.

PERIODISK KONTROL:

- Alle bevægelige dele skal kunne bevæges frit.
- Kontroller deflektoren (drivske) for beskadigelser, skift om nødvendigt.
- Kontroller dysen. En beskadiget dyse kan resultere i en deformeret stråle, og forårsage at sprederen ikke fungerer korrekt.
- Hvis en spredere har gentagne funktionsfejl, bør den efterses af Deres forhandler.

Handhavande instruktioner

Svenska

VIKTIGT

Denna Handhavande instruktion måste ges till operatören. Före användande av TRIGON storspridare läs noga genom dessa instruktioner. Spara dessa instruktioner för framtida bruk.

**VARNING**

- Gör inga justeringar eller kontroller när spridaren är i drift.
- Stå ej inom spridarens aktionsradie.
- Stå ej så att ni kan träffas av vattenstrålen från spridaren.
- Försäkra er att vattenstrålen inte riktas mot personer, kraftledningar, vägar, hus eller andra föremål.
- Före driftstagande skall operatören förvisa sig om att ingen obehörig står inom spridarens aktionsradie.

HANDHAVANDE INSTRUKTIONER

(se ritning)

1. Montera spridaren:

Om spridaren är försedd med fläns anslutning använd medföljande packning och bultar vid monteringen. Se till att bultarna blir ordentligt dragna (Trigon 105). Om spridaren är försedd med gänganslutning, använd gängtätning och drag åt. Använd nyckel eller rörtång för att späna åt.

2. Munstycke:

För att byta munstycke använd medföljande munstycksnyckel för att lossa munstycksmuttern. Byt munstycke och kontrollera att nya munstycket ej är skadat, slitet och sätts i rätt. Spänn muttern först försiktigt för hand så att muttern tar rätt gäng. Spänn efter med munstycks nyckel.

Varning: Behandla munstyckena försiktigt, trä inte munstyckena på ståltråd då innerytan kan skadas. Munstycken är en försliitningdel och ska bytas med jämna mellanrum.

3. Inställning av sektor spridning:

För att ställa in sektorn, vrid ena inställningsringen genom att skjuta på armen från insidan till ena ändläget. Vrid därefter den andra ringen till andra ändläget. Kontrollera genom att vrida kanonen från ändläge till ändläge och kontrollera när pendelarmen skiftar läge.

4. Vari Angel System variabel utgångsvinkel:

Lossa låsmuttrarna, välj lämplig vinkel. Spänn åter låsmuttrarna.

PERIODISKA KONTROLLER:

- Alla rörliga delar skall löpa lätt.
- Att strålskeden ej är skadat eller slitet.
- Kontrollera munstycket. Ett skadat munstycke resulterar att strålen ej centreras och kan påverka funktionen på spridaren
- Kontakta din säljare om spridaren inte fungerar ordentligt.

VIKTIG

Denne instruksjon må overleveres til brukeren. Før TRIGON vannkanon settes i drift, må driftsinstruksjonen leses nøye. Ta vare på instruksjonen for framtidige spørsmål.

**ADVARSEL**

- Foreta ingen justeringer eller kontroll mens kanonen er i drift.
- Stå ikke i kanonens sektorområde.
- Stå ikke i vannstrålen.
- Vannstrålen må ikke rettes inn mot personer, kraftlinjer, veier, bygninger eller andre objekter.
- Før vannkanonen settes i drift, pass på at ingen personer står i kanonens arbeidsområde.

IGANGSETTING

(se skisse)

1. Montering:

Dersom vannkanonen har flens, bruk den medleverte pakning og boltene for montering til stativ og trekk muttrene godt til (Trigon 105). Er vannkanonen levert med et gjenget adapter - må dette skrues godt til med en nøkkel.

2. Dyse:

For montering/skifte av dyse - bruk spesiell dysenøkkel. For stramming av hettemutteren - kontroller at dysen sitter riktig i hettemutteren for å unngå skade på dyse eller hettemutter. Trekk til med hand.

Viktig: Dysen må behandles forsiktig. De bør ikke lagres tredd inn på en streng eller lignende som kan ripe opp innvendige vannflater.

3. Drift i sektor:

For innstilling i sektor - trekk stoppringen til ønsket sektor. Press ikke mot stoppringen ved innstilling - den vil kun låse seg.

4. Vari-Angle system:

Løs låsemutteren, nå kan ønsket strålevinkel instilles. Trekk til låsemutteren.

PERIODISK VEDLIKEHOLD:

- Alle bevegelige deler må kunne bevegges fritt.
- Kontroller skjeen på drivpendelen - skift skjeen dersom skade.
- Kontroller dysen. En skadet dyse gir ikke en rund og kompakt stråle som igjen kan forårsake funksjonsfeil på vannkanon.
- Feilfunksjon som oppstår ved at drivpendelen tipper over fra side til side bør kontrolleres av forhandler eller annen kvalifisert service.

Инструкция по эксплуатации

Русский язык

Важно

Эта инструкция по эксплуатации должна быть передана пользователю. Перед началом использования разбрызгивателя TRIGON внимательно прочтите всю инструкцию. Храните её должным образом.

**ОПАСНОСТЬ**

- Никогда не проводите проверку или регулировку при работающем разбрызгивателе.
- Не разрешается находиться в зоне действия разбрызгивателя.
- Не стойте на траектории высоконапорной струи.
- Не допускается направлять струю воды на людей, электрические провода, дороги, здания и другие предметы.
- Перед подачей давления в разбрызгиватель убедитесь, что никто из людей не находится в рабочей зоне разбрызгивателя.

ВВОД В ЭКСПЛУАТАЦИЮ

(см. рисунки)

1. Установка разбрызгивателя:

Установите резьбовое соединение с помощью болтов на основание разбрызгивателя, тщательно затяните болты (Trigon 105). Затем прикрутите разбрызгиватель к стойке и крепко затяните трубным ключом.

2. Форсунка:

Выберите желаемый размер форсунки и замените. Перед затягиванием накидной гайки обратите внимание, чтобы форсунка была правильно посажена на ствол во избежание повреждений, как самого ствола, так и форсунки.

Важно: Обращайтесь и храните форсунки бережно. Не подвешивайте форсунку шпагатом или проволокой, это может повредить ее.

3. Секторный полив:

Для установки сектора разведите в стороны по одному секторные кольца до желаемого угла сектора или продвиньте их изнутри, но не снаружи, т.к. это может привести к заклиниванию.

4. Система Vari-Angle:

Открутите стопорные гайки, установите желаемый угол наклона струи. Снова закрутите стопорные гайки.

ПЕРИОДИЧЕСКИЙ КОНТРОЛЬ:

- Все движущиеся части должны быть легко подвижны.
- Проверьте отражатель струи на предмет повреждений, при необходимости замените его.
- Проверьте целостность форсунки. Ненаправленная, некомпактная струя может стать причиной неисправностей.
- При неполадках в работе, вызванных неоднократным опрокидыванием стойки разбрызгивателя, проверьте разбрызгиватель у дилера.

Kezelési útmutató

Magyar

FONTOS!

Ezt a kezelési útmutatót át kell adni a kezelőnek. A TRIGON sugárágyú üzembehelyezése előtt ezt az útmutatót figyelmesen olvassa el és őrizze meg.

**VESZÉLYHELYZET!**

- Soha ne végezzen beállítást vagy ellenőrzést, ha a sugárágyú üzemel.
- Ne tartózkodjon a sugárágyú hatósugarában.
- Ne álljon a nagynyomású vízsugár irányvonalában.
- Ne irányítsa a vízsugarat személyre, elektromos vezetékre, útra, épülete vagy más tárgyra
- Mielőtt a sugárágyút nyomás alá helyezné, győződjön meg arról, hogy senki nem tartózkodik a hatótávolságon belül.

ÜZEMBEHELYEZÉS

(lásd az ábrákat)

1. A sugárágyú felszerelése:

A menetes csatlakozást a csavarokkal erősítse a sugárágyú talpához. Csavarokat jól húzza meg (Trigon 102/105). Ezután csavarja fel a rögzítő a tartócsőre és csőfogó segítségével rögzítse.

2. Fúvóka:

Válassza és cserélje ki a kívánt fúvókát. A hollandi anya meghúzása előtt ügyeljen arra, hogy a fúvóka jól fektüdjön az acélcsövön, hogy az acélcső és a fúvóka sérülését elkerüljük. Fontos: A fúvókákat gondosan kezelje és tárolja. Ne kösse fel madzaggal vagy dróttal, mert funkciózavart okozhat.

3. Szektoros öntözés:

A határoló gyűrűket egyenként a végüknél fogva húzza el a kívánt helyzetbe. Állításkor a gyűrű végét kifelé húzza és ne befele tolja, mert akkor a gyűrű szorul.

4. Vari-Angle:

A rögzítőanyát lazítsa fel, majd a beállító csavarral a kívánt sugárszöveget állítsa be. A rögzítőanyát gondosan húzza meg.

IDO SZAKOS ELLENŐRZÉSEK:

- Minden mozgó rész könnyen járjon
- A sugáritköztető lemez ép legyen, szükség esetén cserélje ki.
- A fúvóka ép legyen. A nem gömbölyű és tömör vízsugár működési zavart okozhat.
- Ha a működési zavar a sugárágyú tartó ismételt eldőlését okozza, forduljon szakemberhez.

ΠΡΟΣΟΧΗ

Οι οδηγίες αυτές πρέπει να δίνονται στο χειριστή. Πριν χρησιμοποιήσετε το κανόνι TRIGON, διαβάστε προσεκτικά τις οδηγίες. Κρατήστε τις οδηγίες για μελλοντική χρήση.

**ΚΙΝΔΥΝΟΣ**

- Μην κάνετε καμιά ρύθμιση ή έλεγχο όταν ο εκτοξευτήρας είναι σε λειτουργία
- Απομακρυνθείτε από την ακτίνα δράσης του εκτοξευτήρα.
- Απομακρυνθείτε από την υψηλής πίεσης δέσμη του νερού.
- Βεβαιωθείτε ότι η δέσμη του νερού δεν κατευθύνεται σε ανθρώπους, ηλεκτρικές γραμμές, δρόμους, κτίρια ή άλλα αντικείμενα.
- Πριν θέσετε σε λειτουργία τον εκτοξευτήρα, βεβαιωθείτε ότι δεν υπάρχουν άνθρωποι στην περιοχή ακτίνας δράσης του.

ΔΙΑΔΙΚΑΣΙΕΣ ΕΚΚΙΝΗΣΗΣ
(βλέπε σχέδιο)**1. Τοποθέτηση του εκτοξευτήρα:**

Τοποθετήστε τον βιδωτό προσαρμογέα στη βάση του εκτοξευτήρα και βιδώστε τον με τις βίδες που υπάρχουν στη συσκευασία (Trigon 105). Στη συνέχεια βιδώστε τον εκτοξευτήρα πάνω στο σταντ και σφίξτε γερά με ένα γαλλικό κλειδί.

2. Στόμιο:

Αλλάξτε το στόμιο με αυτό που θέλετε. Πριν ξανασφίξετε το καπάκι του ακροφυσίου βεβαιωθείτε ότι το στόμιο είναι σωστά στερεωμένο πάνω στο σωλήνα για την αποφυγή ζημιών στο σωλήνα ή στο ακροφύσιο. Βιδώστε προσεκτικά με το κλειδί της συσκευασίας.

Προσοχή: Είναι απαραίτητη η σωστή μεταχείριση των στομίων. Δεν πρέπει να σφίγγονται με σύρμα ή σχοινί πάνω στο σωλήνα γιατί μπορεί να φθαρούν.

3. Λειτουργία μερικού κύκλου:

Για να επτευχθεί η λειτουργία μερικού κύκλου, φέρτε

τους μοχλούς (στοπ) στην κατάλληλη θέση τραβώντας τους από το ένα τους άκρο μόνον ή σπρώχνοντας το ένα άκρο τους μόνον προς τα μέσα. Μην σπρώχνετε τους μοχλούς προς το εσωτερικό από την εξωτερική μεριά γιατί θα μπλοκάρουν.

4. Σύστημα Vari Angle:

Χαλαρώστε τα παξιμάδια ασφάλισης και στη συνέχεια ρυθμίστε την επιθυμητή γωνία εκτόξευσης. Σφίξτε ξανά τα παξιμάδια.

ΠΕΡΙΟΔΙΚΟΙ ΕΛΕΓΧΟΙ

- Όλα τα κινούμενα μέρη πρέπει να κινούνται ελεύθερα.
- Ελέγξτε τη λεπίδα διασποράς για τυχόν φθορές και αντικαταστήστε τη εάν είναι απαραίτητο.
- Ελέγξτε το στόμιο. Ένα φθαρμένο στόμιο μπορεί να προκαλέσει μη κυκλική και ανομοιογενή δέσμη εκτόξευσης νερού, η οποία θα μπορούσε να προκαλέσει κακή λειτουργία του εκτοξευτήρα.
- Ένας ελαττωματικός εκτοξευτήρας, εξαιτίας συνεχών πτώσεων από το καρούλι ή τον τρίποδα θα πρέπει να ελεγχθεί από τον αντιπρόσωπό σας.

Spare Parts | Trigon 105

	ENGLISH Description	DEUTSCH Bezeichnung	ITALIANO Denominazione	FRANCAIS Désignation	Q.ty Stk. Q.tà Q.té	Part Number Artikel-Nummer Codice Articolo Référence Pièce
A.00.0	Kit Housing/2"NPT PC	Kit Körper/2"NPT PC	Kit Corpo/2"NPT PC	Kit Corps/2"NPT PC	1	07010249
A.00.1	Kit Housing/2"BSP PC	Kit Körper/2"BSP PC	Kit Corpo/2"BSP PC	Kit Corps/2"BSP PC	1	07010250
A.00.2	Kit Housing/2"NPT FC	Kit Körper/2"NPT FC	Kit Corpo/2"NPT FC	Kit Corps/2"NPT FC	1	07010251
A.00.3	Kit Housing/2"BSP FC	Kit Körper/2"BSP FC	Kit Corpo/2"BSP FC	Kit Corps/2"BSP FC	1	07010252
A1	Housing cover	Deckel für Körper	Coperchio cuscinetto	Couvercle corps	1	04010275
A2	Housing bearing	Lagergehäuse	Corpo cuscinetto	Corps roulement	1	04010274
A3	Collar bearing	Stützlager	Cuscinetto reggispinta	Collier roulement	1	04010485
A4	Brake disk	Stahlscheibe für Bremse	Disco freno	Disque frein	2	02010332
A5	Support ring	Stützring	Anello sostegno disco	Anneau soutien	1	04010351
A6	Bolt M6x25	Schraube M6x25	Vite M6x25	Vis M6x25	4	02010230
A7	Retaining ring	Distanzring	Anello ritegno	Anneau de distance	1	04010277
A8	Collar for bearing	Haltesegment für Bremslager	Ghiera per cuscinetto	Collier pour roulement	2	03010073
A9	Trip stop ring	Sektoring	Anello settore	Anneau secteur	2	02010114
A10.1	Base	Sockel	Base	Base	1	03010134
A11	Bolt M6x60	Schraube M6x60	Vite M6x60	Vis M6x60	6	02010229
A12	Washer 6	Scheibe 6	Rondella 6	Rondelle 6	6	02010042
A13	Washer 6	Scheibe 6	Rondella 6	Rondelle 6	6	02010042
A14	Nut M6	Mutter M6	Dado M6	Ecrou M6	6	02010128
A16	Brake pad upper	Bremssegment oben	Pastiglia freno superiore	Pastille frein supérieure	2	04010378
A17	Bearing	Lager	Cuscinetto	Roulement	1	04010276
A18	Brake lining	Bremsscheibe	Pastiglia freno	Pastille frein	1	02010250
A19	O-Ring 6237	O-Ring 6237	O-Ring 6237	O-Ring 6237	1	02010205
A20	Retaining ring	Stützring	Anello sostegno	Anneau de distance	1	04010352
A21	Lip seal	Lippen-Dichtung	Guarnizione a labbro	Joint à levre	1	02010272
A22	Washer 6	Scheibe 6	Rondella 6	Rondelle 6	4	02010042
A23	Bolt M6x35	Schraube M6x35	Vite M6x35	Vis M6x35	4	02010138
A24	Brake spring	Bremsfeder	Molla per freno	Ressort frein	4	02010113
A27.1	Adapter/2"BSP	Anschluss/2"BSP	Attacco/2"BSP	Raccord/2"BSP	1	03010183
A28.1	Adapter/2"NPT	Anschluss/2"NPT	Attacco/2"NPT	Raccord/2"NPT	1	03010182
A29.1	Bolt M8x25	Schraube M8x25	Vite M8x25	Vis M8x25	4	02010176
A30	O-Ring 2425	O-Ring 2425	O-Ring 2425	O-Ring 2425	1	02010206
A31	O-Ring 158	O-Ring 158	O-Ring 158	O-Ring 158	1	02010207
A32	O-Ring 3225	O-Ring 3225	O-Ring 3225	O-Ring 3225	1	02010111
A.00.4	Kit Brake	Kit Bremse	Kit Freno	Kit Frein	1	07010253
A.00.5.1	Kit Adapter thread 2"BSP	Kit Anschluss 2"BSP	Kit Attacco 2"BSP	Kit Raccord 2"BSP	1	07010808
A.00.6.1	Kit Adapter thread 2"NPT	Kit Anschluss 2"NPT	Kit Attacco 2"NPT	Kit Raccord 2"NPT	1	07010807
C.00.0	Kit Drive arm PC	Kit Schwingarm PC	Kit Braccio oscillante PC	Kit Bras oscillant PC	1	07010532
C.00.1	Kit Drive arm FC	Kit Schwingarm FC	Kit Braccio oscillante FC	Kit Bras oscillant FC	1	07010525
C.00.2	Kit Deflector PC	Kit Deflektor PC	Kit Deflettore PC	Kit Déflecteur PC	1	07010355
C.00.3	Kit Deflector FC	Kit Deflektor FC	Kit Deflettore FC	Kit Déflecteur FC	1	07010526
C1	Drive arm	Schwingarm	Braccio oscillante	Bras oscillant	1	04010291
C2	Deflector 36	Deflektor 36	Deflettore 36	Déflecteur 36	1	04010293
C3	Screw EJ-K60x20	Schraube EJ-K60x20	Vite EJ-K60x20	Vis EJ-K60x20	1	02010166
C4	Bushing drive arm	Büchse Schwingarm	Boccola braccio osc.	Douille bras oscillant	2	04010292
C.00.4	Kit Wind Deflector	Kit Wind Deflektor	Kit Vela antivento	Kit Wind Deflecteur	1	07010608
D.00.0	Kit Barrel PC	Kit Strahlrohr PC	Kit Tubo di lancio PC	Kit Fût PC	1	07010530
D.00.1	Kit Barrel FC	Kit Strahlrohr FC	Kit Tubo di lancio FC	Kit Fût FC	1	07010527
D5	Washer 8	Scheibe 8	Rondella 8	Rondelle 8	2	02010041
D6	Bolt M8x20	Schraube M8x20	Vite M8x20	Vis M8x20	2	02010036
D7	Plate 10'-26'	Platte 10'-26'	Targhetta 10'-26'	Plaque 10'-26'	1	04010297
D7.1	Plate	Platte	Targhetta	Plaque	1	04010310
D8	Washer 6.5	Scheibe 6.5	Rondella 6.5	Rondelle 6.5	2	02010160
D9	Butterfly screw	Flügelschraube	Galletto	Vis	2	04010299
D10	Shaft	Welle	Tirante	Pivot	1	04010308
D11.12	Taper bore nozzle 12 mm / 0.47"	Weitwurfdüse 12 mm / 0.47"	Ugello conico 12 mm / 0.47"	Buse lng portée 12 mm / 0.47"	1	04010224
D11.14	Taper bore nozzle 14 mm / 0.55"	Weitwurfdüse 14 mm / 0.55"	Ugello conico 14 mm / 0.55"	Buse lng portée 14 mm / 0.55"	1	04010225
D11.16	Taper bore nozzle 16 mm / 0.63"	Weitwurfdüse 16 mm / 0.63"	Ugello conico 16 mm / 0.63"	Buse lng portée 16 mm / 0.63"	1	04010226
D11.18	Taper bore nozzle 18 mm / 0.71"	Weitwurfdüse 18 mm / 0.71"	Ugello conico 18 mm / 0.71"	Buse lng portée 18 mm / 0.71"	1	04010227
D11.20	Taper bore nozzle 20 mm / 0.79"	Weitwurfdüse 20 mm / 0.79"	Ugello conico 20 mm / 0.79"	Buse lng portée 20 mm / 0.79"	1	04010228
D11.22	Taper bore nozzle 22 mm / 0.87"	Weitwurfdüse 22 mm / 0.87"	Ugello conico 22 mm / 0.87"	Buse lng portée 22 mm / 0.87"	1	04010229
D11.24	Taper bore nozzle 24 mm / 0.94"	Weitwurfdüse 24 mm / 0.94"	Ugello conico 24 mm / 0.94"	Buse lng portée 24 mm / 0.94"	1	04010230

Spare Parts | Trigon 105

	ENGLISH Description	DEUTSCH Bezeichnung	ITALIANO Denominazione	FRANCAIS Désignation	Q.ty Stk. Q.tà Q.té	Part Number Artikel-Nummer Codice Articolo Référence Pièce
D12	Nozzle holder	Überwurfmutter	Bocchettone	Ecrou buse	1	04010280
D30	Nut M6	Mutter M6	Dado M6	Ecrou M6	1	02010128
D30.1	Nut M6-AB	Mutter M6-AB	Dado M6-AB	Ecrou M6-AB	1	02010139
F.00.0	Kit Cross leverage FC	Kit Gabel FC	Kit Crociera FC	Kit Fourche FC	1	07010529
F.00.1	Kit Cross leverage PC	Kit Gabel PC	Kit Crociera PC	Kit Fourche PC	1	07010360
F.00.2	Kit Trip lever	Kit Schalthebel	Kit Leva settore	Kit Levier inversion	1	07010356
F.00.3	Kit Trip spring	Kit Sektorfeder	Kit Molla settore	Kit Ressort inversion	1	07010357
F.00.4	Kit Trip leverage	Kit Sektorhebel	Kit Leva settore	Kit Levier inversion	1	07010358
F.00.5	Kit Shaft PC	Kit Welle PC	Kit Perno PC	Kit Pivot PC	1	07010359
F.00.6	Kit Fork for drive arm	Kit Gabel für Schwingarm	Kit Forcella per braccio Osc.	Kit Fourche pour bras osc.	1	07010361
F.00.7	Kit Shaft FC	Kit Welle FC	Kit Perno FC	Kit Pivot FC	1	07010528
F1	Fork for drive arm	Gabel für Schwingarm	Forcella per braccio osc.	Fourche pour bras oscillant	2	04010284
F2	Washer 8	Scheibe 8	Rondella 8	Rondelle 8	2	02010041
F3	Bolt M8x25	Schraube M8x25	Vite M8x25	Vis M8x25	2	02010176
F4	Washer 6.5	Scheibe 6.5	Rondella 6.5	Rondelle 6.5	2	02010160
F5	Screw E-J-K60x20	Schraube E-J-K60x20	Vite E-J-K60x20	Vis E-J-K60x20	4	02010166
F6	Washer 8	Scheibe 8	Rondella 8	Rondelle 8	2	02010041
F7	Washer 0.7	Scheibe 0.7	Rondella 0.7	Rondelle 0.7	6	02010149
F8	Shaft drive arm	Welle Schwingarm	Perno braccio oscillante	Pivot bras oscillant	1	04010309
F9	Cross PC	Kreuzwelle PC	Crociera PC	Croisière PC	1	04010283
F10	Spring for fork	Feder für Gabel	Molla per forcella	Ressort pour fourche	1	02010245
F11	Washer 0.7	Scheibe 0.7	Rondella 0.7	Rondelle 0.7	1	02010149
F12	Dust seal	Abstreif-Dichtung	Guarnizione raschiatore	Joint antipoussière	1	02010119
F13	Dust seal	Abstreif-Dichtung	Guarnizione raschiatore	Joint antipoussière	1	02010119
F14	Washer	Scheibe	Rondella scorrimento	Rondelle	1	02010123
F15	Retaining ring	Halte Ring	Anello ritegno	Anneau distance	1	04010306
F16	Pin	Federring	Anello elastico	Cheville	1	02010231
F17	Trip shift lever external	Schalthebel aussen	Leva scatto esterno	Levier déclenchement externe	2	04010286
F18	Washer 0.7	Scheibe 0.7	Rondella 0.7	Rondelle 0.7	5	02010149
F19	Trip shift lever internal	Schalthebel innen	Leva scatto interna	Levier déclenchement interne	2	04010287
F20	Nut M5	Mutter M5	Dado M5	Ecrou M5	2	02010129
F21	Washer 5	Scheibe 5	Rondella 5	Rondelle 5	2	02010040
F22	Shaft trip lever	Sektorwelle	Perno leva settore	Pivot levier inversion	1	04010307
F23	Trip shift lever VA	Sektorhebel VA	Leva scatto settore VA	Levier inversion VA	1	04010311
F24	Washer	Scheibe	Rondella	Rondelle	1	04010194
F25	Bolt M8x20	Schraube M8x20	Vite M8x20	Vis M8x20	1	02010036
F26	Shaft sleeve	Welle für Hülse	Perno bussola	Pivot douille	1	04010305
F27	Plug sleeve	Kappe für Hülse	Tappo bussola	Bouchon douille	1	04010198
F28	Trip spring	Feder für Schaltung	Molla scatto settore	Ressort inversion	1	02010221
F29	Spring sleeve	Federhülse	Bussola scatto settore	Douille ressort	1	02010120
F30	Shaft sleeve	Welle für Hülse	Perno bussola	Pivot douille	1	04010304
F31	Guide for sleeve	Gleitnöpfe für Hülse	Nottolino per bussola	Taquet pour douille	1	04010197
F32	Cross FC	Kreuzwelle FC	Crociera FC	Croisière FC	1	04010312
F33	Spacer	Distanzring	Distanziale	Entretoise	2	04010314
G.00.0	Kit Elbow 10'-26'	Kit Kurve 10'-26'	Kit Curva 10'-26'	Kit Coude 10'-26'	1	07010531
G1	Elbow 10'-26'	Kurve 10'-26'	Curva 10'-26'	Coude 10'-26'	1	04010281
G3	Lip seal	Lippen-Dichtung	Guarnizione a labbro	Joint à levre	1	02010239
G4	Nut M6	Mutter M6	Dado M6	Ecrou M6	4	02010128
G5	Washer 6	Scheibe 6	Rondella 6	Rondelle 6	4	02010042
G6	Nut M8	Mutter M8	Dado M8	Ecrou M8	2	02010038

Grey shaded part numbers: not available as single parts, please select appropriate kit/assembly • Grau hinterlegte Ersatzteile: einzeln nicht erhältlich, sondern nur im entsprechenden Ersatzteil-Kit • Pezzi di ricambio su fondo grigio: non fornibili singolarmente, selezionare il kit ricambio desiderato • Pièces de rechange sur fond gris: ne sont pas disponibles séparément, sélectionner le kit pièces souhaite • Las referencias sombreadas en gris: no están disponibles como piezas solas, por favor seleccione el equipo/conjunto apropiado apropiado • Peças com números sombreados de cinza: não disponíveis como peças individuais, por favor, seleccione o conjunto/montagem apropriado.

Spare Parts | Trigon 112

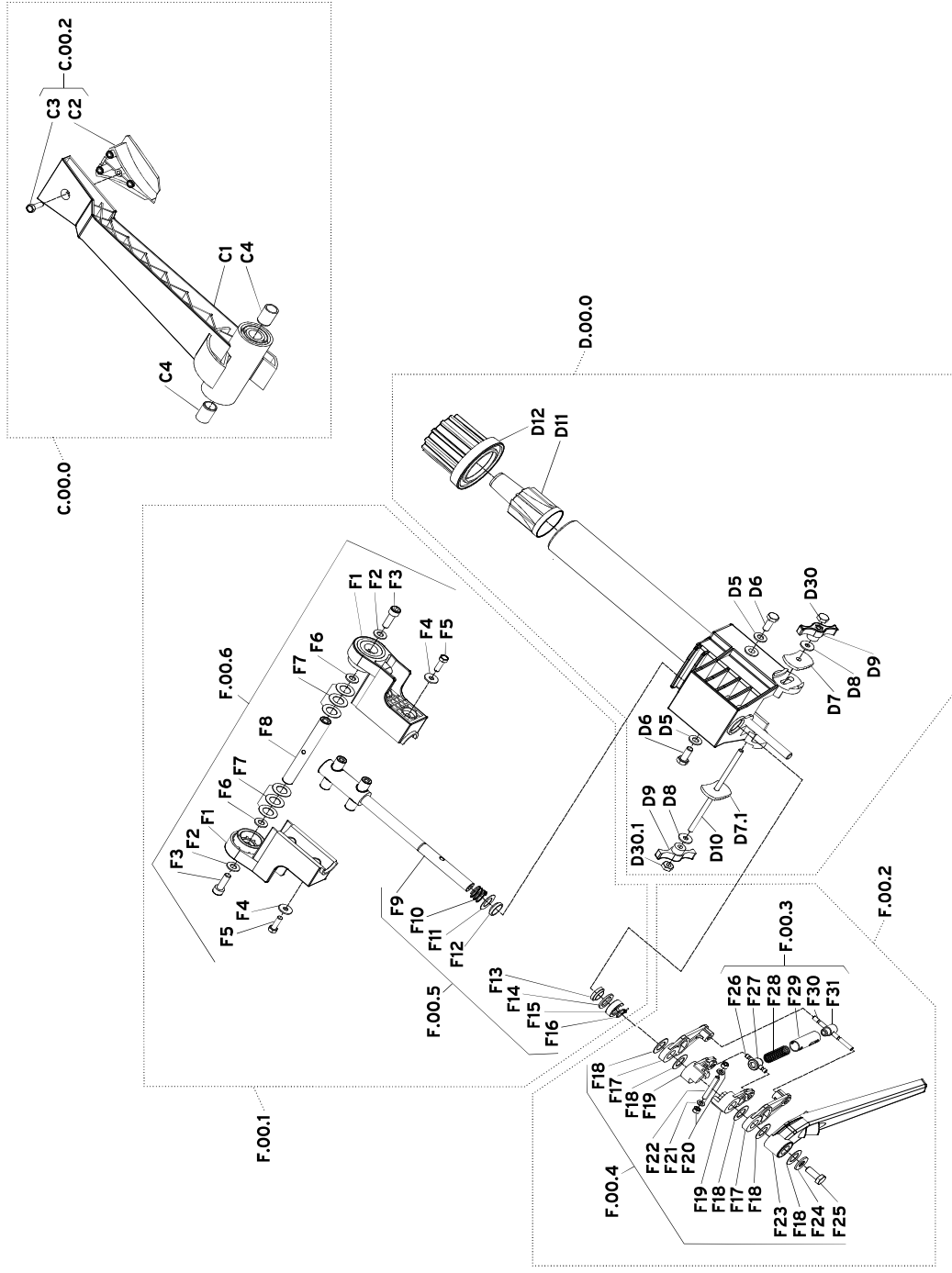
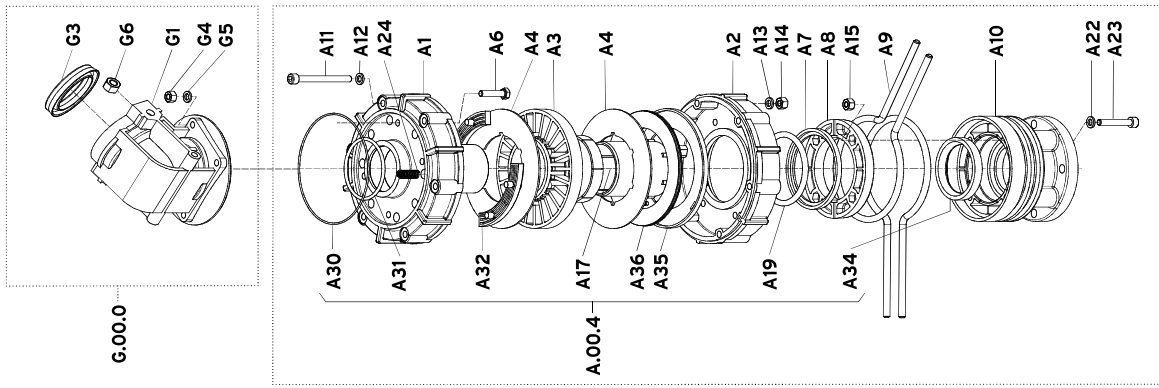

Spare Parts | Trigon 112

	ENGLISH Description	DEUTSCH Bezeichnung	ITALIANO Denominazione	FRANCAIS Désignation	Q.ty Stk. Q.tà Q.té	Part Number Artikel-Nummer Codice Articolo Référence Pièce
A.00.0	Kit Housing/2"NPT PC	Kit Körper/2"NPT PC	Kit Corpo/2"NPT PC	Kit Corps/2"NPT PC	1	07010555
A.00.1	Kit Housing/2"BSP PC	Kit Körper/2"BSP PC	Kit Corpo/2"BSP PC	Kit Corps/2"BSP PC	1	07010556
A1	Housing cover	Deckel für Körper	Coperchio cuscinetto	Couvercle corps	1	04010425
A2	Housing bearing	Lagergehäuse	Corpo cuscinetto	Corps roulement	1	04010423
A3	Collar bearing	Stützlager	Cuscinetto reggispinta	Collier roulement	1	04010421
A4	Brake disk	Stahlscheibe für Bremse	Disco freno	Disque frein	2	02010204
A6	Bolt M6x25-4	Schraube M6x25-4	Vite M6x25-4	Vis M6x25-4	4	02010210
A7	Retaining ring	Distanzring	Anello ritegno	Anneau de distance	1	04010426
A8	Collar for bearing	Haltesegment für Bremslager	Ghiera cuscinetto	Collier pour roulement	2	04010424
A9	Trip stop ring	Sektoring	Anello settore	Anneau secteur	2	02010232
A10	Base 2"NPT	Sockel 2"NPT	Base 2"NPT	Base 2"NPT	1	04010446
A11	Bolt M6x60-4	Schraube M6x60-4	Vite M6x60-4	Vis M6x60-4	6	02010208
A12	Washer 6-4	Scheibe 6-4	Rondella 6-4	Rondelle 6-4	6	02010211
A13	Washer 6-4	Scheibe 6-4	Rondella 6-4	Rondelle 6-4	6	02010211
A14	Nut M6-4	Mutter M6-4	Dado M6-4	Ecrou M6-4	6	02010212
A15	Nut M6-4	Mutter M6-4	Dado M6-4	Ecrou M6-4	4	02010212
A17	Bearing	Lager	Cuscinetto	Roulement	1	04010422
A19	O-Ring 6237 VT	O-Ring 6237 VT	O-Ring 6237 VT	O-Ring 6237 VT	1	02010234
A22	Washer 6-4	Scheibe 6-4	Rondella 6-4	Rondelle 6-4	4	02010211
A23	Bolt M6x35-4	Schraube M6x35-4	Vite M6x35-4	Vis M6x35-4	4	02010209
A24	Brake spring	Bremsfeder	Molla per freno	Ressort frein	4	02010113
A30	O-ring 2425 VT	O-Ring 2425 VT	O-ring 2425 VT	O-ring 2425 VT	1	02010235
A31	O-ring 158 VT	O-Ring 158 VT	O-ring 158 VT	O-ring 158 VT	1	02010236
A32	Brake pad upper	Bremssegment oben	Pastiglia freno superiore	Pastille frein supérieure	2	04010458
A34	Lip seal VT	Lippen-Dichtung VT	Guarnizione a labbro VT	Joint à levre VT	1	02010233
A35	Support ring	Stützring	Anello sostegno disco	Anneau soutien	1	04010468
A36	Brake lining	Bremsscheibe	Pastiglia freno	Pastille frein	1	02010250
A.00.4	Kit Brake	Kit Bremse	Kit Freno	Kit Frein	1	07010557
C.00.0	Kit Drive arm PC	Kit Schwingarm PC	Kit Braccio oscillante PC	Kit Bras oscillant PC	1	07010558
C.00.2	Kit Deflector PC	Kit Deflektor PC	Kit Deflettore PC	Kit Déflecteur PC	1	07010559
C1	Drive arm	Schwingarm	Braccio oscillante	Bras oscillant	1	04010439
C2	Deflector 36	Deflektor 36	Deflettore 36	Déflecteur 36	1	04010440
C3	Screw EJ-K60x20	Schraube EJ-K60x20	Vite EJ-K60x20	Vis EJ-K60x20	1	02010166
C4	Bushing drive arm	Büchse Schwingarm	Boccola braccio osc.	Douille bras oscillant	2	04010443
D.00.0	Kit Barrel PC	Kit Strahlrohr PC	Kit Tubo di lancio PC	Kit Fût PC	1	07010560
D5	Washer 8-4	Scheibe 8-4	Rondella 8-4	Rondelle 8-4	2	02010217
D6	Bolt M8x20-4	Schraube M8x20-4	Vite M8x20-4	Vis M8x20-4	2	02010215
D7	Plate 10'-26'	Platte 10'-26'	Targhetta 10'-26'	Plaque 10'-26'	1	04010431
D7.1	Plate	Platte	Targhetta	Plaque	1	04010432
D8	Washer 6.5-4	Scheibe 6.5-4	Rondella 6.5-4	Rondelle 6.5-4	2	02010218
D9	Butterfly screw	Flügelsschraube	Galletto	Vis	2	04010433
D10	Shaft	Welle	Tirante	Pivot	1	04010298
D11.12	Taper bore nozzle 12 mm / 0.47"	Weitwurfdüse 12 mm / 0.47"	Ugello conico 12 mm / 0.47"	Buse lng portée 12 mm / 0.47"	1	04010451
D11.14	Taper bore nozzle 14 mm / 0.55"	Weitwurfdüse 14 mm / 0.55"	Ugello conico 14 mm / 0.55"	Buse lng portée 14 mm / 0.55"	1	04010452
D11.16	Taper bore nozzle 16 mm / 0.63"	Weitwurfdüse 16 mm / 0.63"	Ugello conico 16 mm / 0.63"	Buse lng portée 16 mm / 0.63"	1	04010450
D11.18	Taper bore nozzle 18 mm / 0.71"	Weitwurfdüse 18 mm / 0.71"	Ugello conico 18 mm / 0.71"	Buse lng portée 18 mm / 0.71"	1	04010453
D11.20	Taper bore nozzle 20 mm / 0.79"	Weitwurfdüse 20 mm / 0.79"	Ugello conico 20 mm / 0.79"	Buse lng portée 20 mm / 0.79"	1	04010454
D11.22	Taper bore nozzle 22 mm / 0.87"	Weitwurfdüse 22 mm / 0.87"	Ugello conico 22 mm / 0.87"	Buse lng portée 22 mm / 0.87"	1	04010455
D11.24	Taper bore nozzle 24 mm / 0.94"	Weitwurfdüse 24 mm / 0.94"	Ugello conico 24 mm / 0.94"	Buse lng portée 24 mm / 0.94"	1	04010456
D12	Nozzle holder	Überwurfmutter	Bocchettone	Ecrou buse	1	04010449
D30	Nut M6-4	Mutter M6-4	Dado M6-4	Ecrou M6-4	1	02010212
D30.1	Nut M6-4-AB	Mutter M6-4-AB	Dado M6-4-AB	Ecrou M6-4-AB	1	02010225
F.00.1	Kit Cross leverage dr. arm PC	Kit Gabel für Schwingarm PC	Kit Crociera per braccio PC	Kit Fourche pour bras osc. PC	1	07010561
F.00.2	Kit Trip leverage	Kit Sektorhebel	Kit Leva settore	Kit Levier inversion	1	07010562
F.00.3	Kit Trip spring	Kit Sektorfeder	Kit Molla scatto settore	Kit Ressort inversion	1	07010563
F.00.4	Kit Trip leverage	Kit Sektorhebel	Kit Leva settore	Kit Levier inversion	1	07010564
F.00.5	Kit Shaft PC	Kit Welle PC	Kit Perno PC	Kit Pivot PC	1	07010565

Spare Parts | Trigon 112

	ENGLISH Description	DEUTSCH Bezeichnung	ITALIANO Denominazione	FRANCAIS Désignation	Q.ty Stk. Q.tà Q.té	Part Number Artikel-Nummer Codice Articolo Référence Pièce
F.00.6	Kit Fork for drive arm	Kit Gabel für Schwingarm	Kit Forcella per braccio osc.	Kit Fourche pour bras osc.	1	07010566
F1	Fork for drive arm	Gabel für Schwingarm	Forcella per braccio osc.	Fourche pour bras oscillant	2	04010435
F2	Washer 8-4	Scheibe 8-4	Rondella 8-4	Rondelle 8-4	2	02010217
F3	Bolt M8x25-4	Schraube M8x25-4	Vite M8x25-4	Vis M8x25-4	2	02010223
F4	Washer 6.5-4	Scheibe 6.5-4	Rondella 6.5-4	Rondelle 6.5-4	2	02010218
F5	Screw E.J-K60x20	Schraube E.J-K60x20	Vite E.J-K60x20	Vis E.J-K60x20	4	02010166
F6	Washer 8-4	Scheibe 8-4	Rondella 8-4	Rondelle 8-4	2	02010217
F7	Washer 0.7	Scheibe 0.7	Rondella 0.7	Rondelle 0.7	6	02010149
F8	Shaft drive arm	Welle Schwingarm	Perno braccio oscillante	Pivot bras oscillant	1	04010294
F9	Cross PC	Kreuzwelle PC	Crociera PC	Croisière PC	1	04010434
F10	Spring for fork	Feder für Gabel	Molla per forcella	Ressort pour fourche	1	02010267
F11	Washer 0.7	Scheibe 0.7	Rondella 0.7	Rondelle 0.7	1	02010149
F12	Dust seal VT	Abstreif-Dichtung VT	Guarnizione raschiatore VT	Joint antipoussière VT	1	02010238
F13	Dust seal VT	Abstreif-Dichtung VT	Guarnizione raschiatore VT	Joint antipoussière VT	1	02010238
F14	Washer	Scheibe	Rondella scorrimento	Rondelle	1	02010123
F15	Retaining ring	Halte Ring	Anello ritegno	Anneau distance	1	04010285
F16	Pin	Federring	Anello elastico	Cheville	1	02010231
F17	Trip shift lever external	Schalthebel aussen	Leve scatto esterna	Levier déclenchement externe	2	04010437
F18	Washer 0.7	Scheibe 0.7	Rondella 0.7	Rondelle 0.7	5	02010149
F19	Trip shift lever internal	Schalthebel innen	Leva scatto interno	Levier déclenchement interne	2	04010438
F20	Nut M5-4	Mutter M5-4	Dado M5-4	Ecrou M5-4	2	02010219
F21	Washer 5-4	Scheibe 5-4	Rondella 5-4	Rondelle 5-4	2	02010220
F22	Shaft trip lever	Sektorwelle	Perno leva settore	Pivot levier inversion	1	04010288
F23	Trip shift lever VA	Sektorhebel VA	Leva scatto settore VA	Levier inversion VA	1	04010436
F24	Washer	Scheibe	Rondella	Rondelle	1	04010194
F25	Bolt M8x20-4	Schraube M8x20-4	Vite M8x20-4	Vis M8x20-4	1	02010215
F26	Shaft sleeve	Welle für Hülse	Perno bussola	Pivot douille	1	04010290
F27	Plug sleeve	Kappe für Hülse	Tappo bussola	Bouchon douille	1	04010442
F28	Trip spring	Feder für Schaltung	Molla scatto settore	Ressort inversion	1	02010221
F29	Spring sleeve	Federhülse	Bussola scatto settore	Douille ressort	1	02010222
F30	Shaft sleeve	Welle für Hülse	Perno Bussola	Pivot douille	1	04010289
F31	Guide for sleeve	Gleitnuppe für Hülse	Nottolino per bussola	Taquet pour douille	1	04010441
G.00.0	Kit Elbow 10'-26'	Kit Kurve 10'-26'	Kit Curva 10'-26'	Kit Coude 10'-26'	1	07010578
G1	Elbow 10'-26'	Kurve 10'-26'	Curva 10'-26'	Coude 10'-26'	1	04010427
G3	Lip seal VT	Lippen-Dichtung VT	Guarnizione a labbro VT	Joint à levre VT	1	02010237
G4	Nut M6-4	Mutter M6-4	Dado M6-4	Ecrou M6-4	4	02010212
G5	Washer 6-4	Scheibe 6-4	Rondella 6-4	Rondelle 6-4	4	02010211
G6	Nut M8-4	Mutter M8-4	Dado M8-4	Ecrou M8-4	2	02010216

Grey shaded part numbers: not available as single parts, please select appropriate kit/assembly • Grau hinterlegte Ersatzteile: einzeln nicht erhältlich, sondern nur im entsprechenden Ersatzteil-Kit • Pezzi di ricambio su fondo grigio: non fornibili singolarmente, selezionare il kit ricambio desiderato • Pièces de rechange sur fond gris: ne sont pas disponibles séparément, sélectionner le kit pièces souhaite • Las referencias sombreadas en gris: no están disponibles como piezas solas, por favor seleccione el equipo/conjunto apropiado • Peças com números sombreados de cinza: não disponíveis como peças individuais, por favor, selecione o conjunto/montagem apropriado.

Trouble Shooting | Trigon 105-112

Trouble Shooting	Possible cause	Correction
SPRINKLER DOES NOT START UP (see: 1, 2, 4, 5)	1 Nozzle damaged	Replace nozzle
SPRINKLER STOPS (see: 1, 2, 3, 4, 5, 6, 7)	2 Deflector damaged	Replace kit deflector
SPRINKLER TURNS SLOWLY (see: 1, 2, 3, 4, 5)	3 Brake pads worn	Replace kit brake
SPRINKLER DOES NOT INVERT (see: 1, 2, 4, 5, 6, 7)	4 Poor pressure	Adjust pressure
	5 Drive arm hindered in its movement	Disassemble and set free
	6 Trip spring damaged	Replace kit trip spring
	7 Trip stop ring out of its grooves	Position trip stop ring correctly

Fehlersuche	Mögliche Ursachen	Abhilfe
REGNER STARTET NICHT (siehe: 1, 2, 4, 5)	1 Düse beschädigt	Düse erneuern
REGNER BLEIBT STEHEN (siehe: 1, 2, 3, 4, 5, 6, 7)	2 Deflektor beschädigt	Kit Deflektor erneuern
REGNER DREHT ZU LANGSAM (siehe: 1, 2, 3, 4, 5)	3 Bremssegmente verbraucht	Kit Bremse erneuern
REGNER WENDET NICHT (siehe: 1, 2, 4, 5, 6, 7)	4 Betriebsdruck zu nieder	Betriebsdruck erhöhen
	5 Schwingarm in seiner Bewegung nicht frei	Abbauen und frei machen
	6 Sektorfeder beschädigt	Kit Sektorfeder erneuern
	7 Sektoring nicht in seiner Nut positioniert	Sektoring in seine Nut geben

Ricerca Guasti	Probabile causa	Rimedio
L'IRRIGATORE NON PARTE (vedi: 1, 2, 4, 5)	1 Ugello danneggiato	Sostituire l'ugello
L'IRRIGATORE SI FERMA (vedi: 1, 2, 3, 4, 5, 6, 7)	2 Deflettore danneggiato	Sostituire il kit deflettore
L'IRRIGATORE GIRA LENTO (vedi: 1, 2, 3, 4, 5)	3 Pastiglie freno usurate	Sostituire il kit freno
L'IRRIGATORE NON INVERTE (vedi: 1, 2, 4, 5, 6, 7)	4 Pressione d'esercizio insufficiente	Aumentare la pressione
	5 Braccio oscillante legato nel suo movimento	Smontare e rimettere a nuovo
	6 Molla scatto settore danneggiata	Sostituire il kit molla scatto settore
	7 Anello settore posizionato fuori dalla sua sede	Posizionare l'anello settore correttamente

Recherche des Pannes	Cause probable	Remède
L'ARROSEUR NE DEMARRE PAS (voir: 1, 2, 4, 5)	1 Buse endommagée	Remplacer la buse
L'ARROSEUR S'ARRETE (voir: 1, 2, 3, 4, 5, 6, 7)	2 Déflecteur endommagé	Remplacer le kit déflecteur
L'ARROSEUR TOURNE LENTEMENT (voir: 1, 2, 3, 4, 5)	3 Pastilles frein usées	Remplacer le kit frein
L'ARROSEUR N'INVERTIT PAS (voir: 1, 2, 4, 5, 6, 7)	4 Pression insuffisante	Augmenter la pression
	5 Bras oscillant entravé dans son mouvement	Démonter et libérer
	6 Ressort inversion endommagé	Remplacer le kit ressort inversion
	7 Anneau secteur hors de son siège	Positionner correctement l'anneau secteur

Busca de los Desperfectos	Probable causa	Remedio
EL ASPERSOR NO INICIA OPERACIÓN (ver: 1, 2, 4, 5)	1 Boquilla dañada	Sustituir la boquilla
EL ASPERSOR PARA (ver: 1, 2, 3, 4, 5, 6, 7)	2 Deflector dañado	Sustituir el kit deflector
EL ASPERSOR ANDA LENTAMENTE (ver: 1, 2, 3, 4, 5)	3 Pastillas de freno desgastadas	Sustituir el kit freno
EL ASPERSOR NO INVERTE (ver: 1, 2, 4, 5, 6, 7)	4 Presión insuficiente	Aumentar la presión
	5 Brazo oscilante obstaculado en su movimiento	Desmontar y liberar
	6 Muelle sector dañada	Sustituir el kit muelle sector
	7 Anillo sector posicionado fuera de su alojamiento	Posicionar correctamente el anillo sector

Identificação de Defeitos	Causa provável	Solução
ASPERSOR NÃO INICIA OPERAÇÃO (veja: 1, 2, 4, 5)	1 Bocal danificado	Substituir o bocal
ASPERSOR PARA (veja: 1, 2, 3, 4, 5, 6, 7)	2 Deflector danificado	Substituir o conjunto deflector
ASPERSOR GIRA LENTAMENTE (veja: 1, 2, 3, 4, 5)	3 Pastilhas do freio desgastadas	Substituir o conjunto freio
ASPERSOR NÃO EXECUTA A REVERSÃO (veja: 1, 2, 4, 5, 6, 7)	4 Pressão insuficiente	Elevar a pressão
	5 Balancim travado	Desmontar e liberar o balancim
	6 Mola do setor danificada	Substituir a mola do setor
	7 Anel do setor fora de seu alojamento	Posicionar corretamente o anel do setor

Never service the gun while in operation.

Niemals während des Betriebes Einstellungen/Wartungen am Regner durchführen.

Non eseguire operazioni sull'apparecchio in funzione.

Ne pas faire des interventions sur le canon en marche.

Nunca efectuar trabajos sobre el cañon en marcha.

Nunca execute operações com o canhão em marcha.

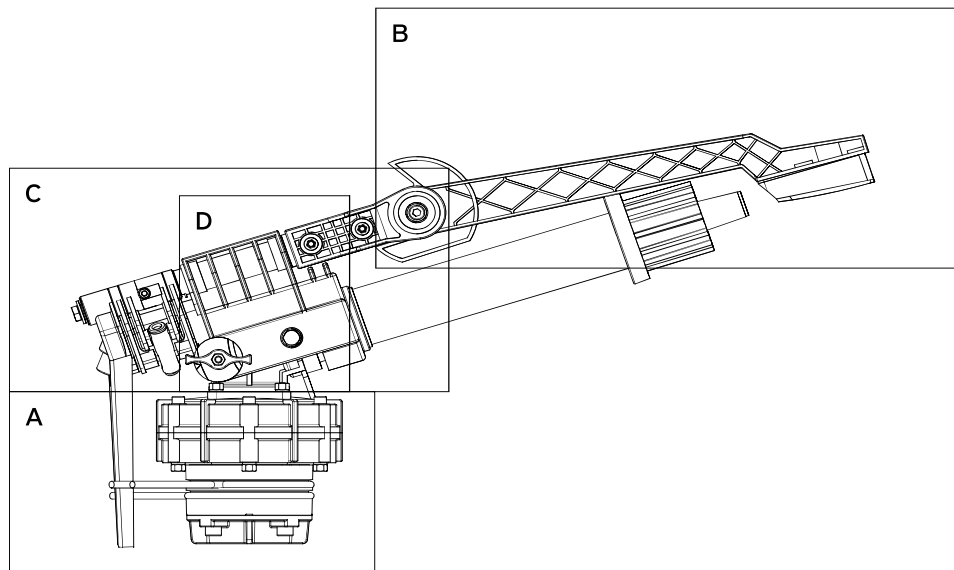

INSTRUCTIONS:

1. All moving parts have to be free.
2. When greasing, use a soft water resistant grease brand.
3. The brake surfaces should never come in contact with grease.
4. If parts have to be replaced, use the Assemblies or Kits as shown in the spare parts list, this assures a simple and complete service. For replacement follow the sequence as shown below.
5. For trouble shooting it is advantageous to have the spare parts list on hand.

ANLEITUNG:

1. Alle Bewegungen müssen frei und leichtgängig sein.
2. Zum Fetten, ein weiches, wasserfestes Fett verwenden.
3. Die Bremsscheiben dürfen niemals mit Fett in Berührung kommen.
4. Beim Austauschen von Teilen sich der Teile-Sätze wie aus der Ersatzteil-Liste hervorgeht (fett gedruckt) bedienen, dadurch ist eine einfache und umfassende Erneuerung gewährleistet. Für den Zusammenbau, die abgebildeten Sequenzen zur Demontage in umgekehrter Reihenfolge ausführen.
5. Bei der Fehlersuche ist es vorteilhaft, die dem Regner beigelegte Ersatzteil-Liste zur Hand zu haben.

ISTRUZIONI:

1. Tutti i movimenti devono essere liberi.
2. Per ingrassare usare un grasso di marca, morbido e resistente all'acqua.
3. Le pastiglie freno non devono venire assolutamente a contatto con grasso.
4. Nella sostituzione di particolari, servirsi del Kit ricambio preconfezionati come indicati nella lista ricambi (neretto), questo assicura una semplice e completo ripristino. Per il montaggio seguire a ritroso le sequenze di smontaggio illustrate.
5. Per la ricerca guasti è utile avere a disposizione la lista ricambi in dotazione all'apparecchio.

INSTRUCTIONS:

1. Toutes les parties articulées doivent se mouvoir librement.
2. Pour graisser, utiliser une bonne graisse molle, résistante à l'eau.
3. Les pastilles frein ne doivent jamais entrer en contact avec la graisse.
4. S'il faut remplacer des pièces, utiliser les kits de rechange tout prêts, indiqués en gras sur la liste des pièces de rechange, ceci garantit une manutention complète et simple. Pour le montage, suivre à rebours les séquences de démontage illustrées.
5. Pour la recherche des pannes, nous conseillons d'avoir à portée de la main la liste des pièces de rechange fournie avec l'arroseur.

INSTRUCCIONES:

1. Todos los movimientos deben ser libres.
2. Para un correcto mantenimiento, usar grasa de calidad de poca densidad (fluida).
3. Las pastillas de freno no deben estar nunca en contacto con grasa.
4. Si debe cambiarse alguna pieza, utilizar los kits de recambios confeccionados que figuran en el catálogo piezas, lo cual garantiza una sencilla y completa reparación. Para el montaje, ver esquemas adjuntos.
5. Para la busca de los desperfectos, aconsejase de tener al alcance de la mano la lista de recambios facilitada con el aspersor.

INSTRUÇÕES:

1. Todos os movimentos devem estar livres.
2. Para lubrificação, usar somente graxa de baixa densidade (fluida) e resistente à água.
3. As pastilhas do freio jamais deverão entrar em contacto com a graxa.
4. Se houver necessidade de reposição de peças, utilizar os conjuntos apresentados no catálogo de peças, esse procedimento garante uma manutenção simples e completa. Seguir os procedimentos de montagem e desmontagem apresentados a seguir.
5. Para a identificação de defeitos, é recomendável manter-se a lista de peças de reposição à mão.



A

Bearing
Hauptlager
Corpo Cuscinetto
Corps Roulement
Cuerpo Cojinete
Conjunto Rolamento

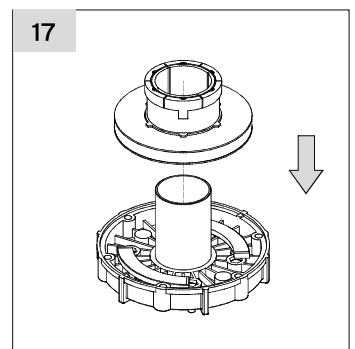
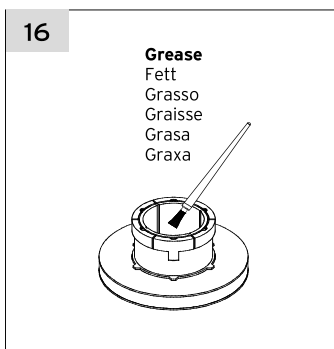
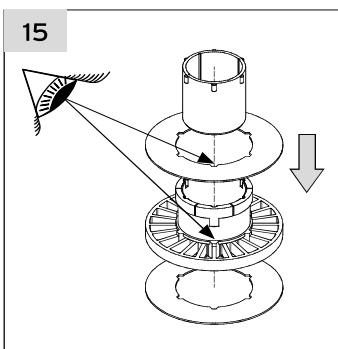
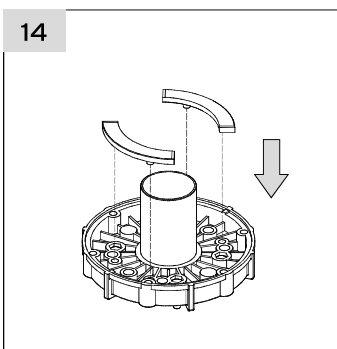
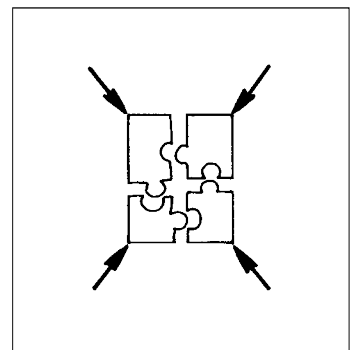
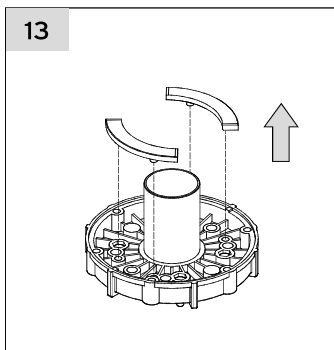
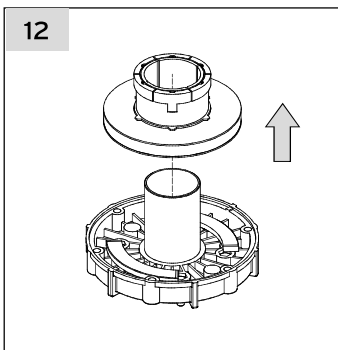
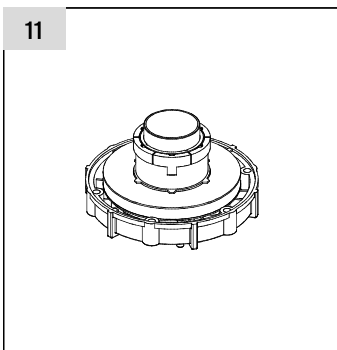
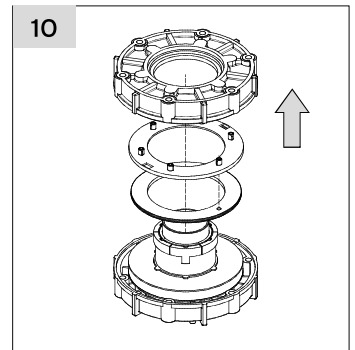
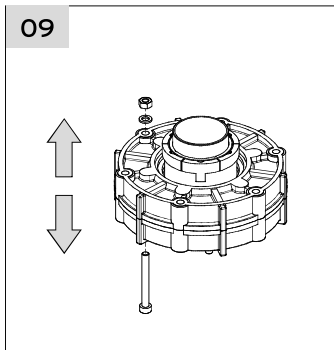
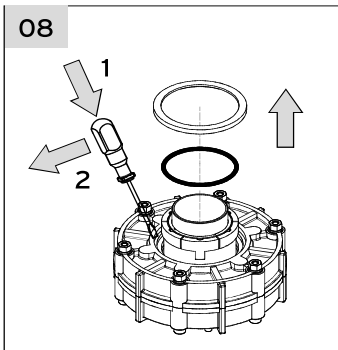
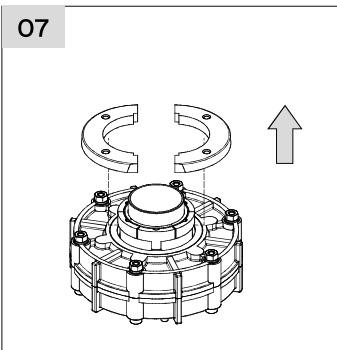
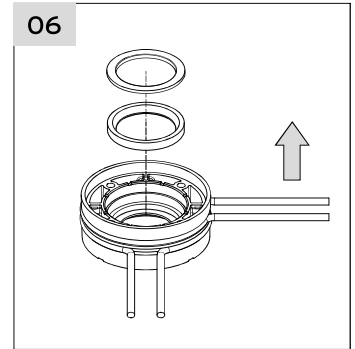
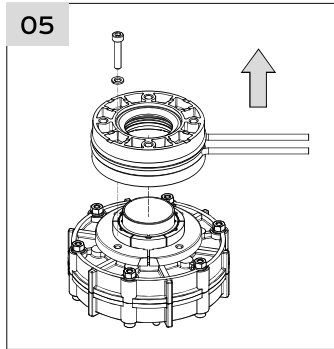
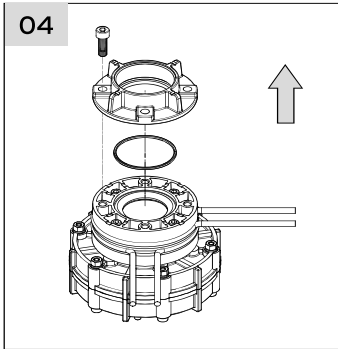
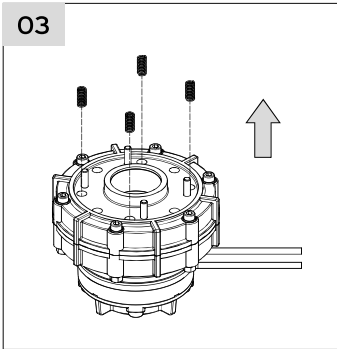
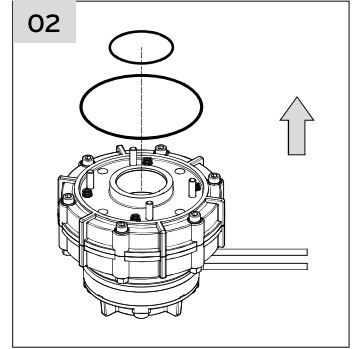
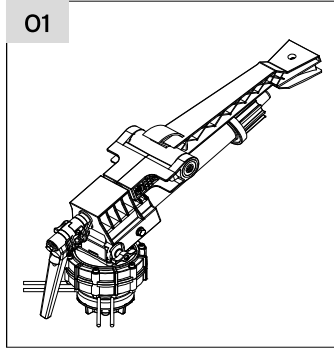
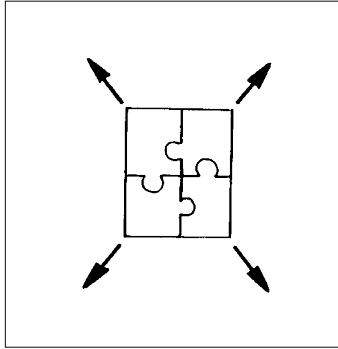

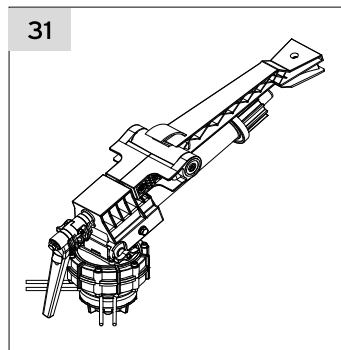
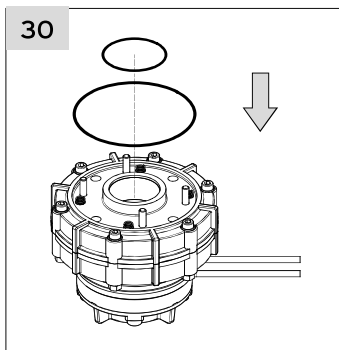
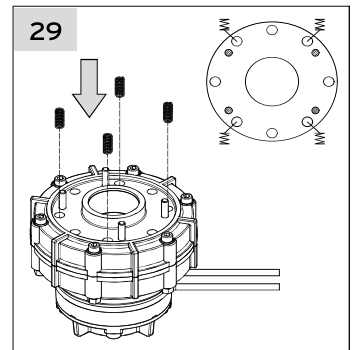
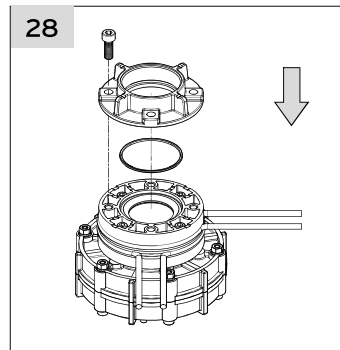
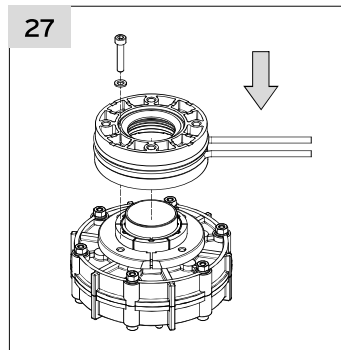
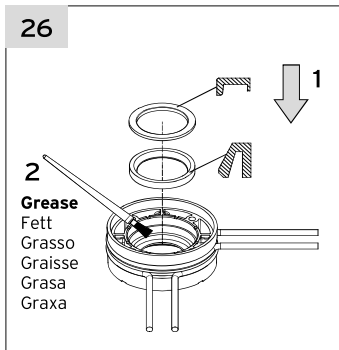
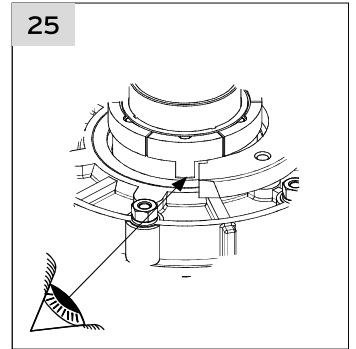
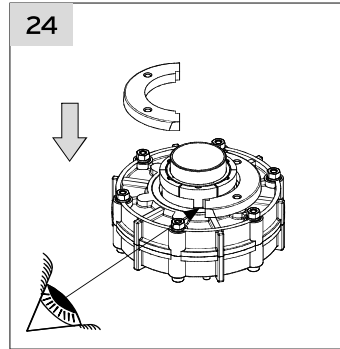
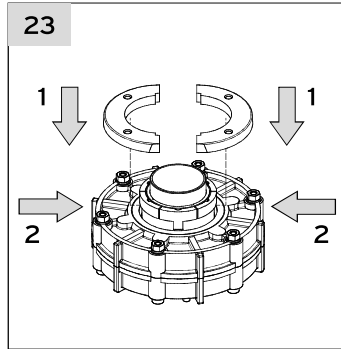
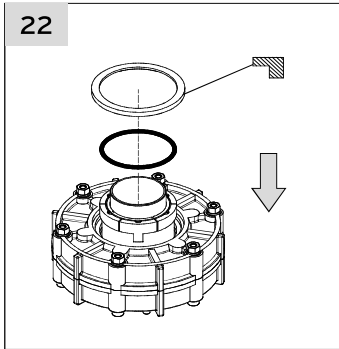
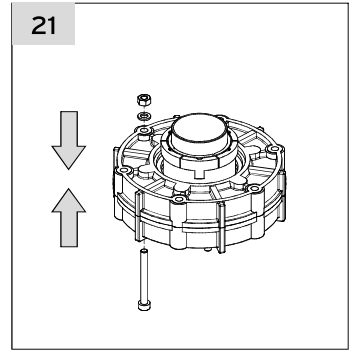
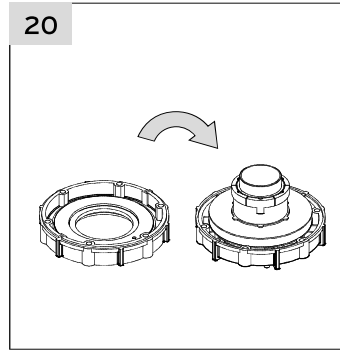
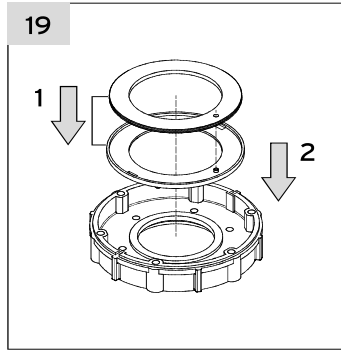
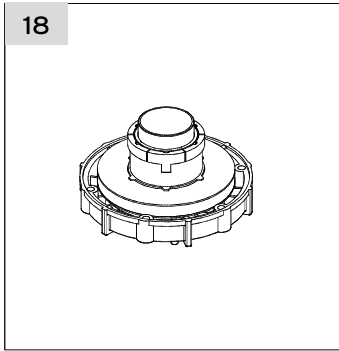

B

Drive arm
Schwingarm
Braccio oscillante
Bras oscillant
Brazo oscilante
Balancim

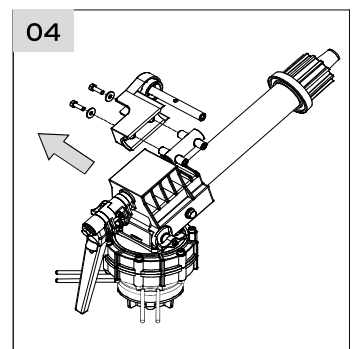
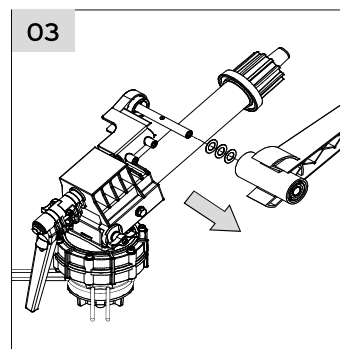
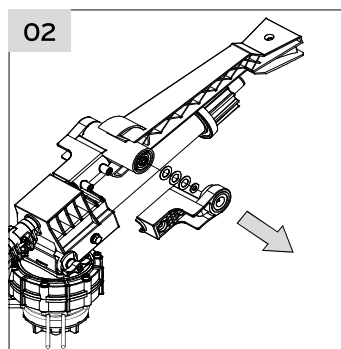
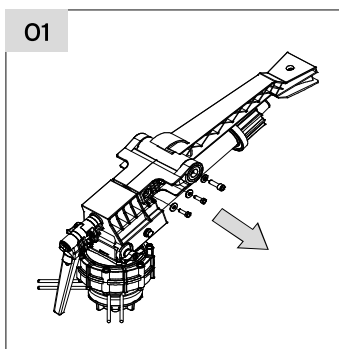
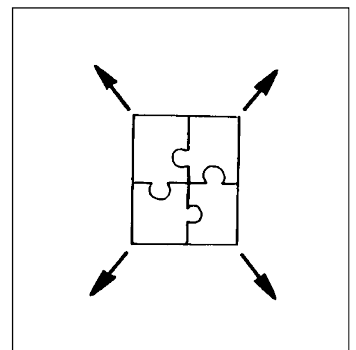

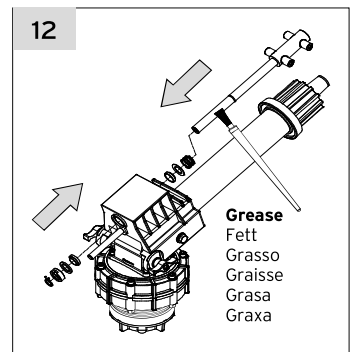
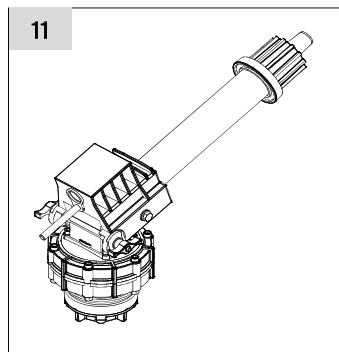
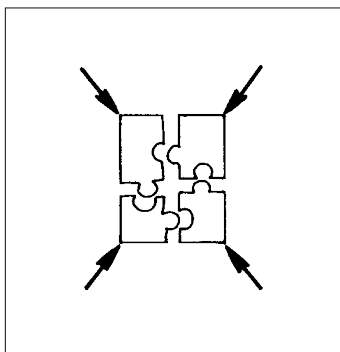
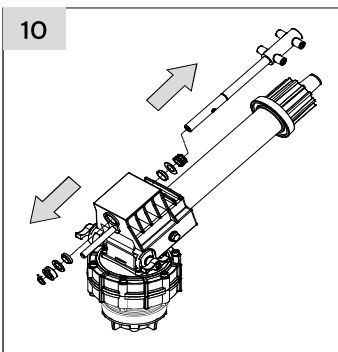
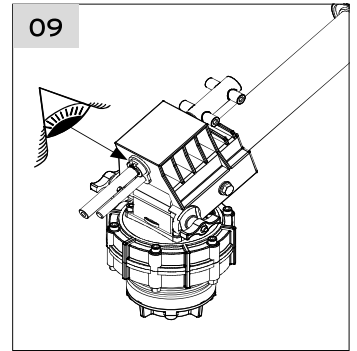
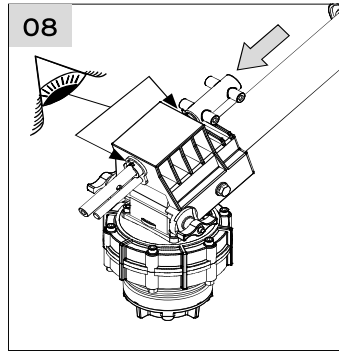
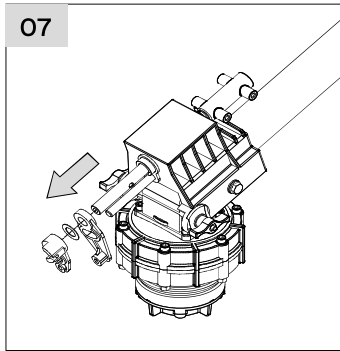
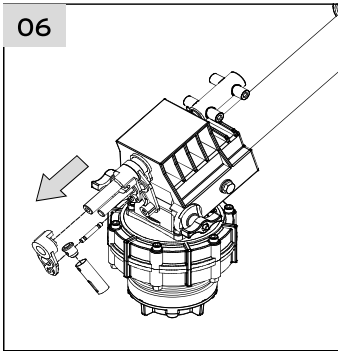
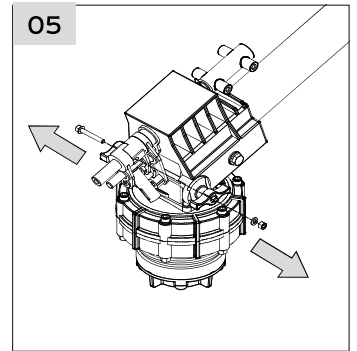
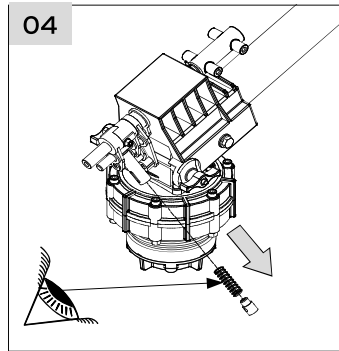
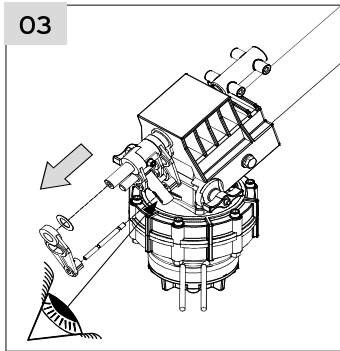
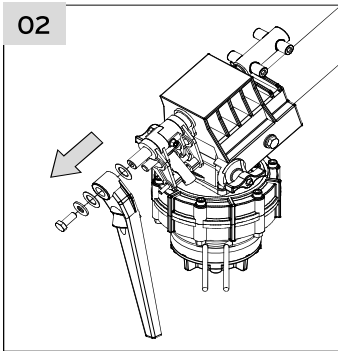
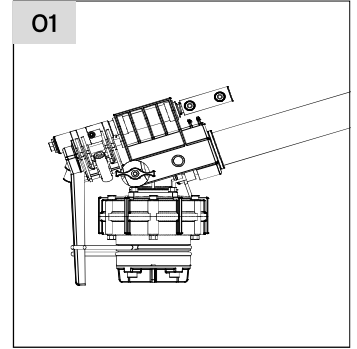
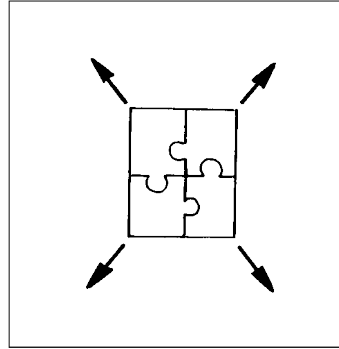
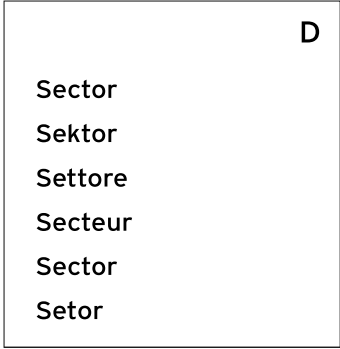
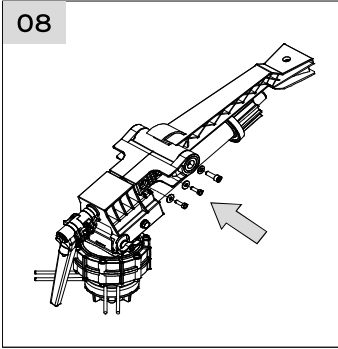
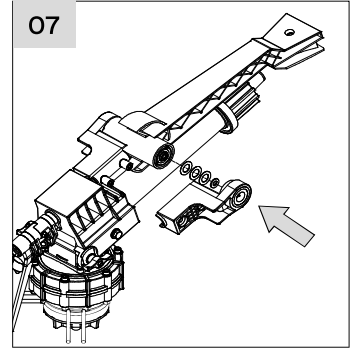
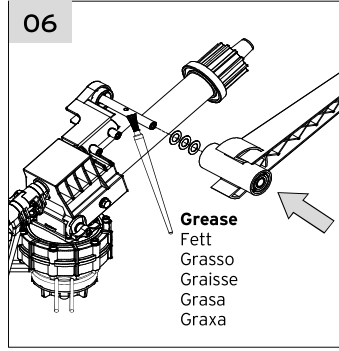
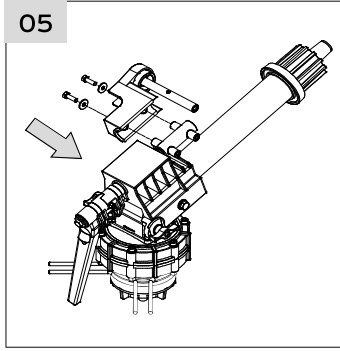
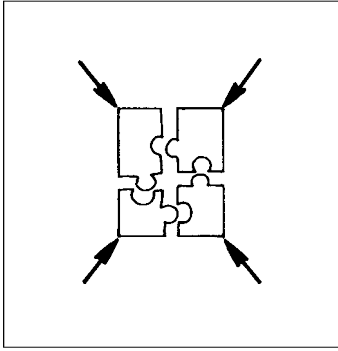

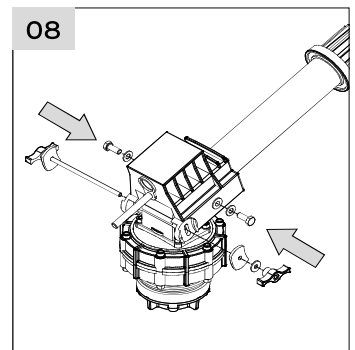
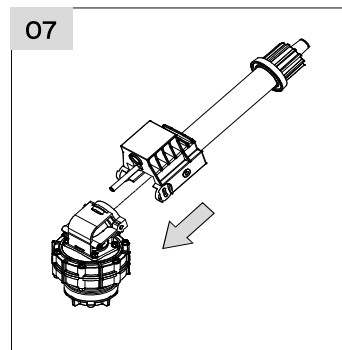
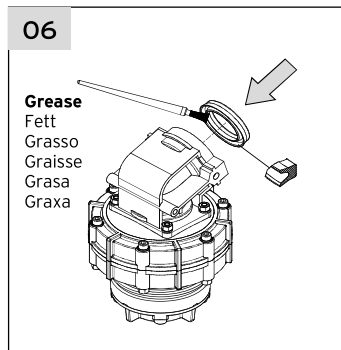
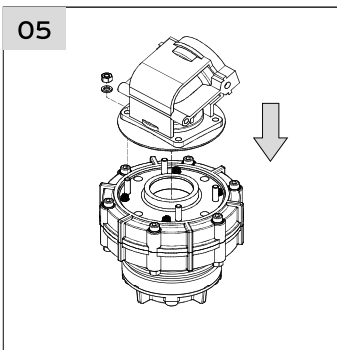
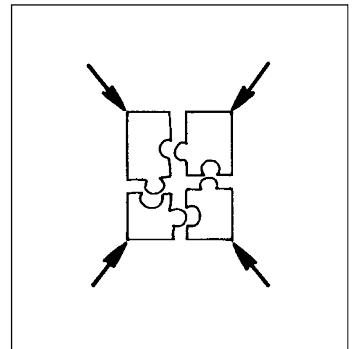
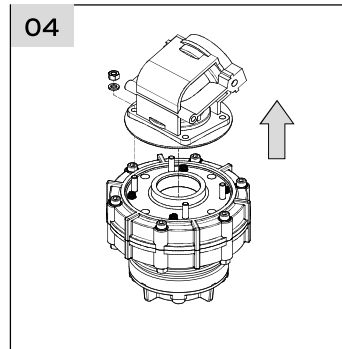
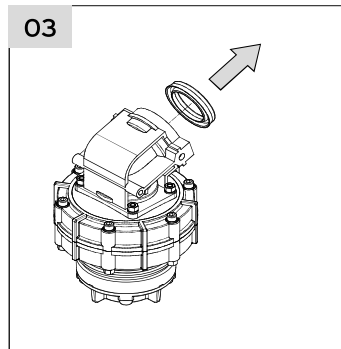
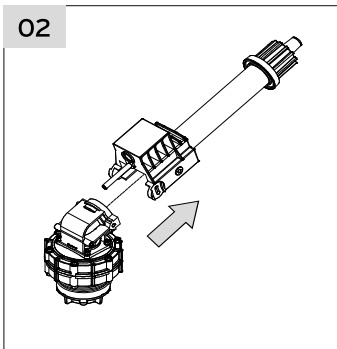
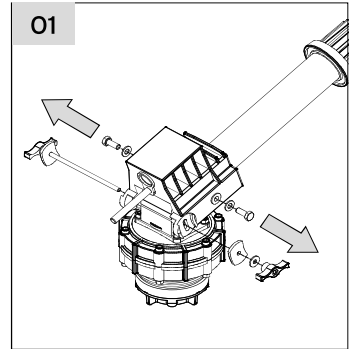
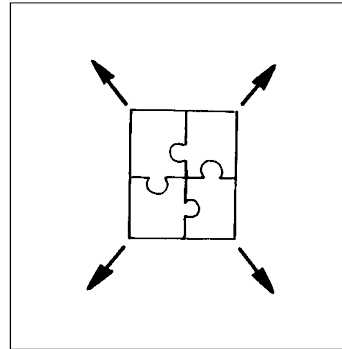
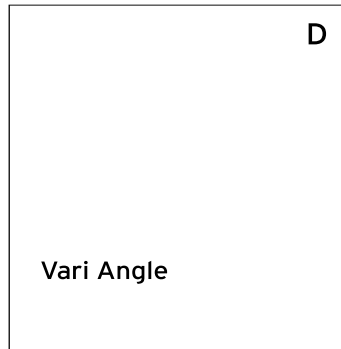
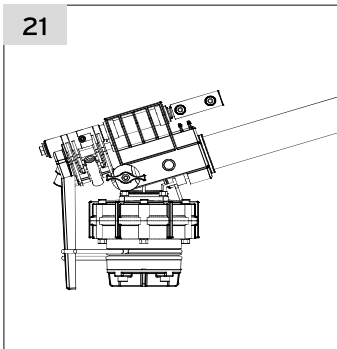
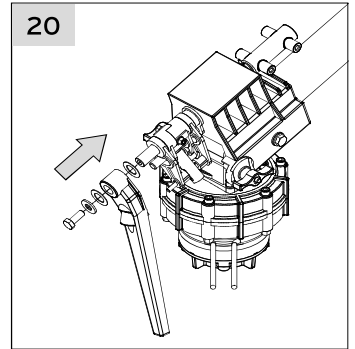
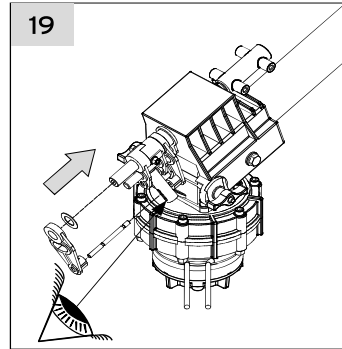
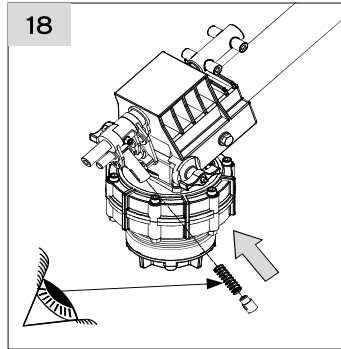
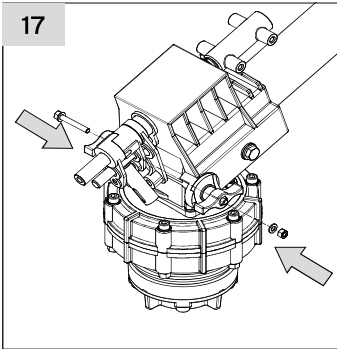
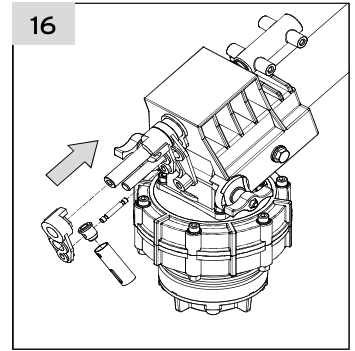
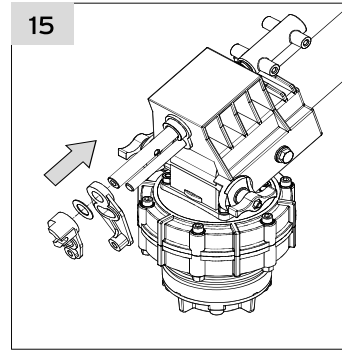
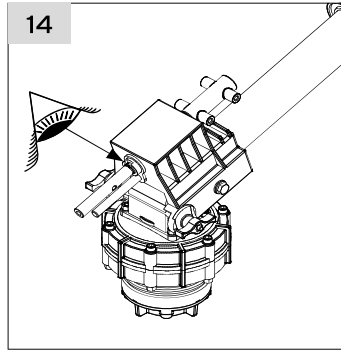
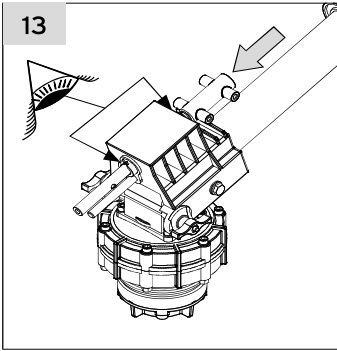

A

Bearing
Hauptlager
Corpo Cuscinetto
Corps Roulement
Cuerpo Cojinete
Conjunto Rolamento

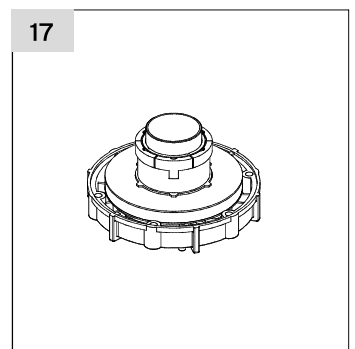
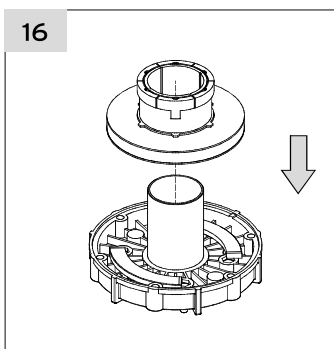
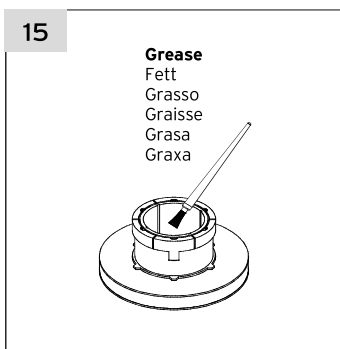
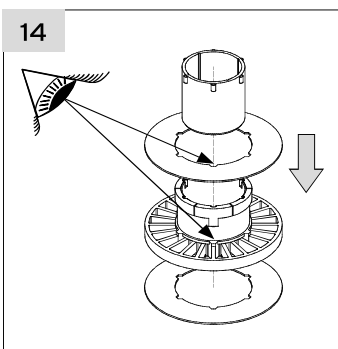
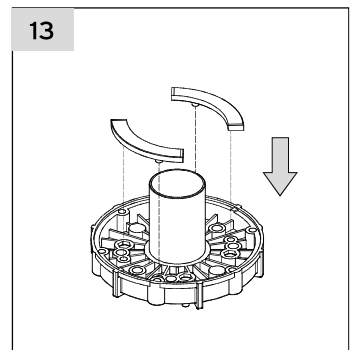
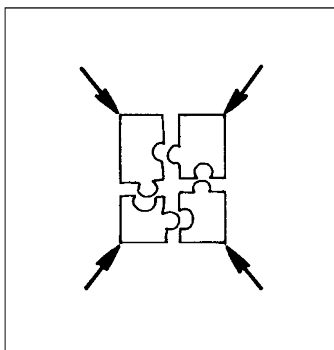
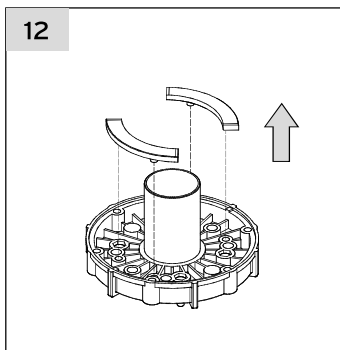
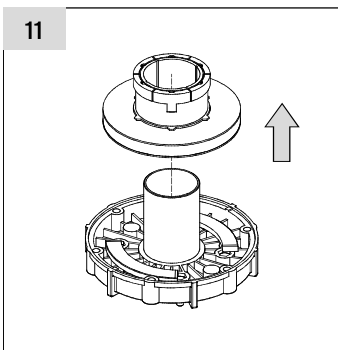
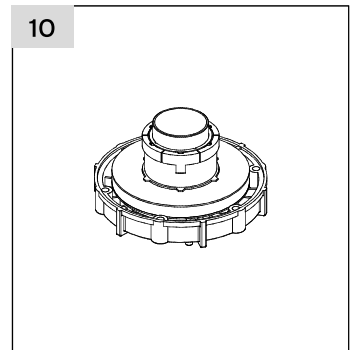
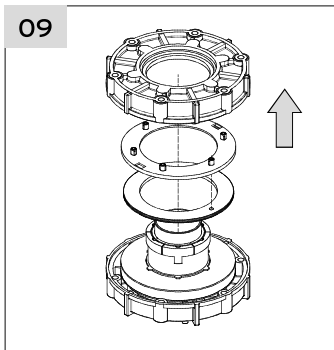
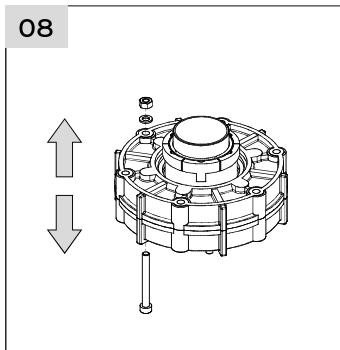
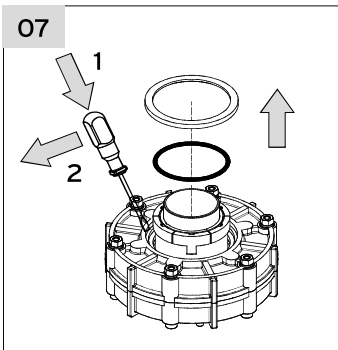
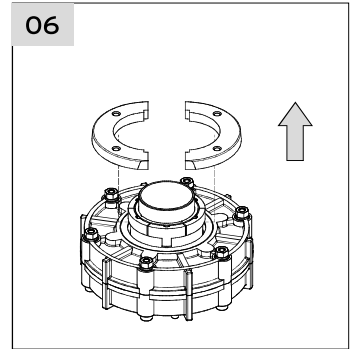
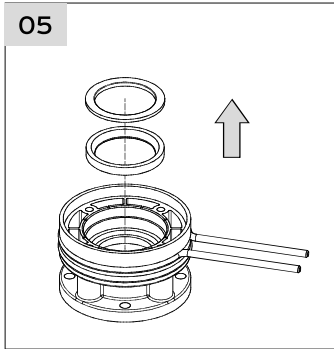
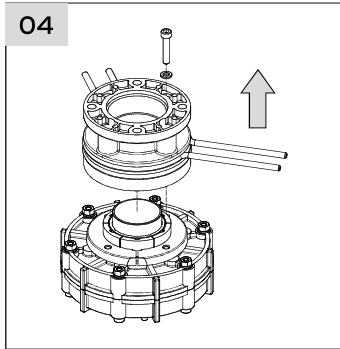
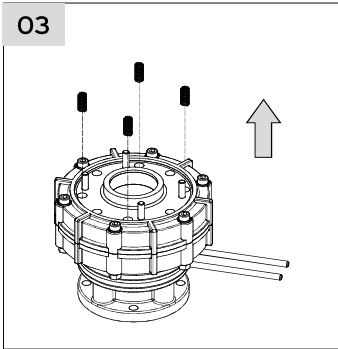
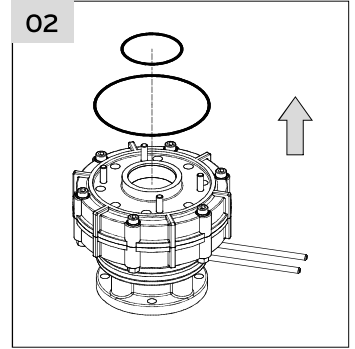
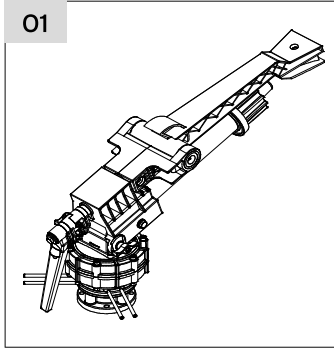
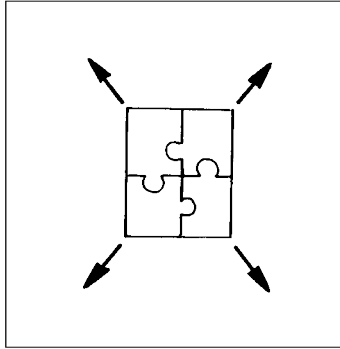

Grease
Fett
Grasso
Graisse
Grasa
Graxa

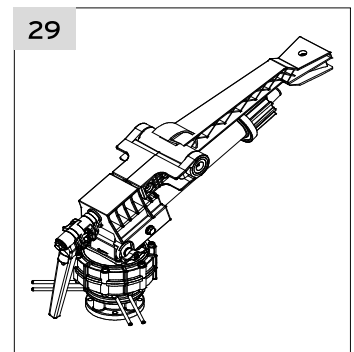
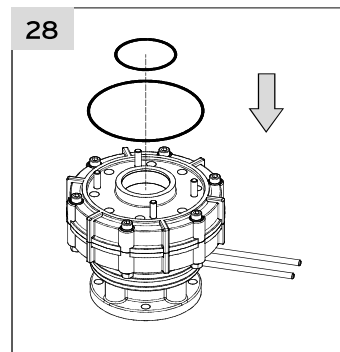
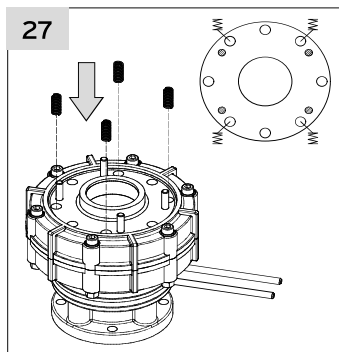
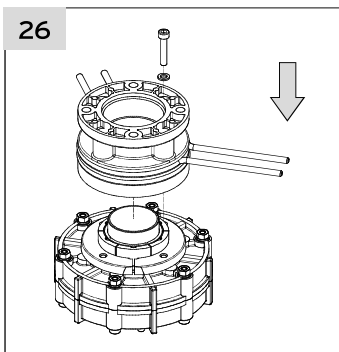
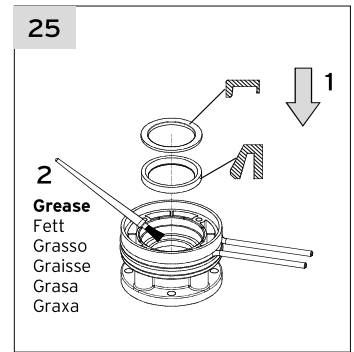
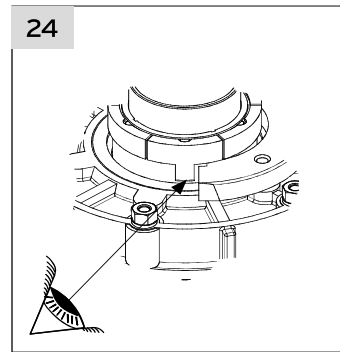
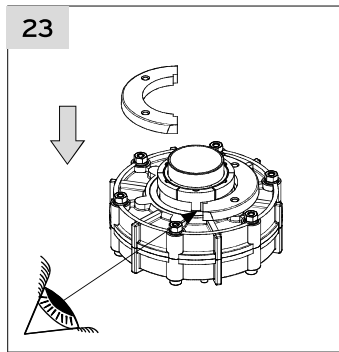
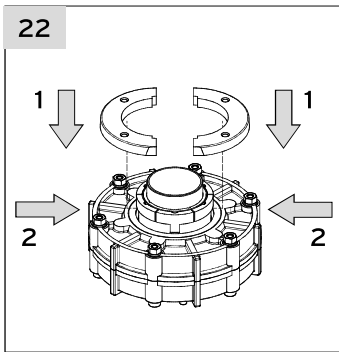
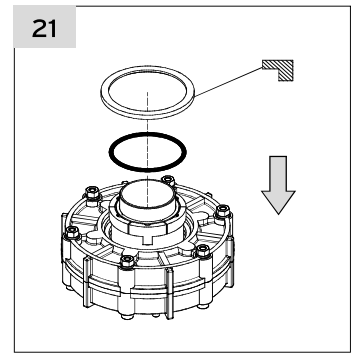
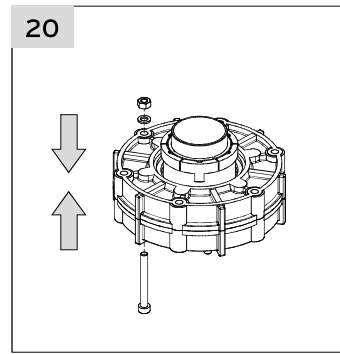
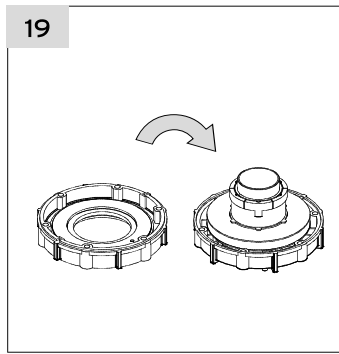
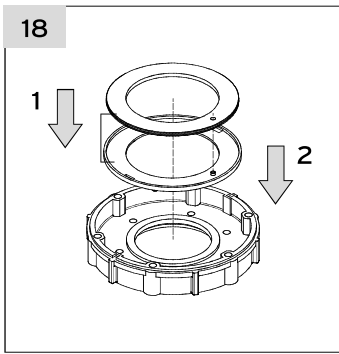

B

Drive arm
Schwingarm
Braccio oscillante
Bras oscillant
Brazo oscilante
Balancim

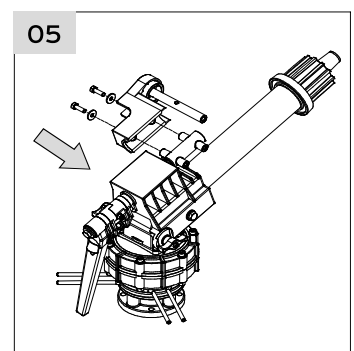
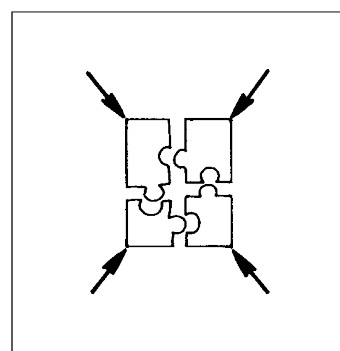
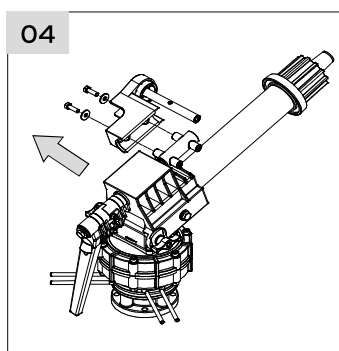
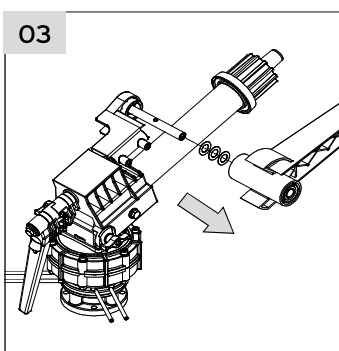
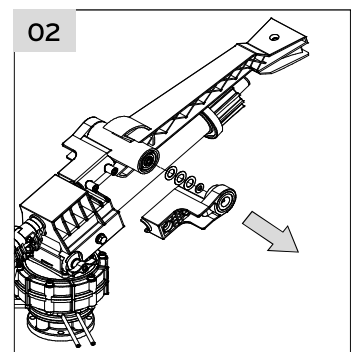
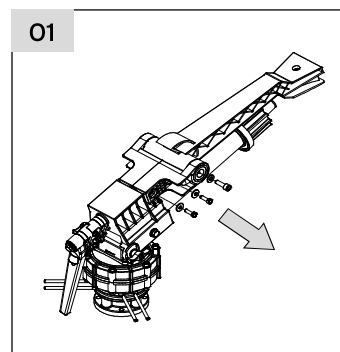
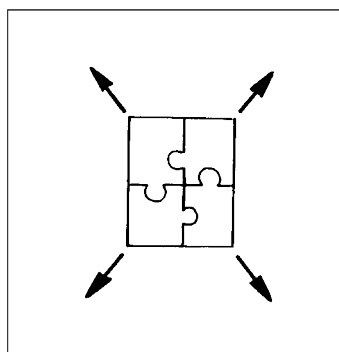

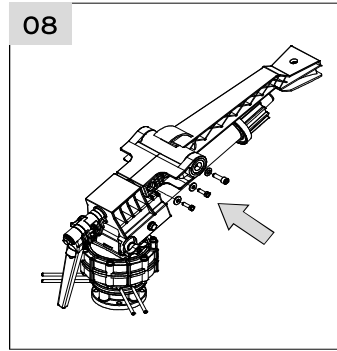
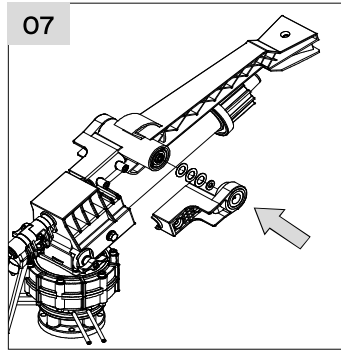
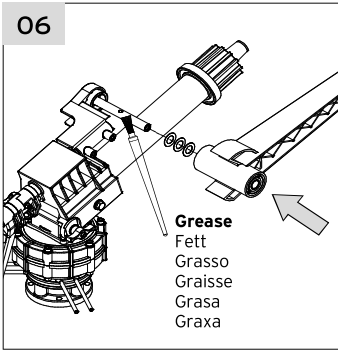

D

Sector
Sektor
Settore
Secteur
Sector
Setor

