

Trouble Shooting | Trigon 105-112

Trouble Shooting	Possible cause	Correction
SPRINKLER DOES NOT START UP (see: 1, 2, 4, 5)	1 Nozzle damaged	Replace nozzle
SPRINKLER STOPS (see: 1, 2, 3, 4, 5, 6, 7)	2 Deflector damaged	Replace kit deflector
SPRINKLER TURNS SLOWLY (see: 1, 2, 3, 4, 5)	3 Brake pads worn	Replace kit brake
SPRINKLER DOES NOT INVERT (see: 1, 2, 4, 5, 6, 7)	4 Poor pressure	Adjust pressure
	5 Drive arm hindered in its movement	Disassemble and set free
	6 Trip spring damaged	Replace kit trip spring
	7 Trip stop ring out of its grooves	Position trip stop ring correctly

Fehlersuche	Mögliche Ursachen	Abhilfe
REGNER STARTET NICHT (siehe: 1, 2, 4, 5)	1 Düse beschädigt	Düse erneuern
REGNER BLEIBT STEHEN (siehe: 1, 2, 3, 4, 5, 6, 7)	2 Deflektor beschädigt	Kit Deflektor erneuern
REGNER DREHT ZU LANGSAM (siehe: 1, 2, 3, 4, 5)	3 Bremssegmente verbraucht	Kit Bremse erneuern
REGNER WENDET NICHT (siehe: 1, 2, 4, 5, 6, 7)	4 Betriebsdruck zu nieder	Betriebsdruck erhöhen
	5 Schwingarm in seiner Bewegung nicht frei	Abbauen und frei machen
	6 Sektorfeder beschädigt	Kit Sektorfeder erneuern
	7 Sektoring nicht in seiner Nut positioniert	Sektoring in seine Nut geben

Ricerca Guasti	Probabile causa	Rimedio
L'IRRIGATORE NON PARTE (vedi: 1, 2, 4, 5)	1 Ugello danneggiato	Sostituire l'ugello
L'IRRIGATORE SI FERMA (vedi: 1, 2, 3, 4, 5, 6, 7)	2 Deflettore danneggiato	Sostituire il kit deflettore
L'IRRIGATORE GIRA LENTO (vedi: 1, 2, 3, 4, 5)	3 Pastiglie freno usurate	Sostituire il kit freno
L'IRRIGATORE NON INVERTE (vedi: 1, 2, 4, 5, 6, 7)	4 Pressione d'esercizio insufficiente	Aumentare la pressione
	5 Braccio oscillante legato nel suo movimento	Smontare e rimettere a nuovo
	6 Molla scatto settore danneggiata	Sostituire il kit molla scatto settore
	7 Anello settore posizionato fuori dalla sua sede	Posizionare l'anello settore correttamente

Recherche des Pannes	Cause probable	Remède
L'ARROSEUR NE DEMARRE PAS (voir: 1, 2, 4, 5)	1 Buse endommagée	Remplacer la buse
L'ARROSEUR S'ARRETE (voir: 1, 2, 3, 4, 5, 6, 7)	2 Déflecteur endommagé	Remplacer le kit déflecteur
L'ARROSEUR TOURNE LENTEMENT (voir: 1, 2, 3, 4, 5)	3 Pastilles frein usées	Remplacer le kit frein
L'ARROSEUR N'INVERTIT PAS (voir: 1, 2, 4, 5, 6, 7)	4 Pression insuffisante	Augmenter la pression
	5 Bras oscillant entravé dans son mouvement	Démonter et libérer
	6 Ressort inversion endommagé	Remplacer le kit ressort inversion
	7 Anneau secteur hors de son siège	Positionner correctement l'anneau secteur

Busca de los Desperfectos	Probable causa	Remedio
EL ASPERSOR NO INICIA OPERACIÓN (ver: 1, 2, 4, 5)	1 Boquilla dañada	Sustituir la boquilla
EL ASPERSOR PARA (ver: 1, 2, 3, 4, 5, 6, 7)	2 Deflector dañado	Sustituir el kit deflector
EL ASPERSOR ANDA LENTAMENTE (ver: 1, 2, 3, 4, 5)	3 Pastillas de freno desgastadas	Sustituir el kit freno
EL ASPERSOR NO INVERTE (ver: 1, 2, 4, 5, 6, 7)	4 Presión insuficiente	Aumentar la presión
	5 Brazo oscilante obstaculado en su movimiento	Desmontar y liberar
	6 Muelle sector dañada	Sustituir el kit muelle sector
	7 Anillo sector posicionado fuera de su alojamiento	Posicionar correctamente el anillo sector

Identificação de Defeitos	Causa provável	Solução
ASPERSOR NÃO INICIA OPERAÇÃO (veja: 1, 2, 4, 5)	1 Bocal danificado	Substituir o bocal
ASPERSOR PARA (veja: 1, 2, 3, 4, 5, 6, 7)	2 Deflector danificado	Substituir o conjunto deflector
ASPERSOR GIRA LENTAMENTE (veja: 1, 2, 3, 4, 5)	3 Pastilhas do freio desgastadas	Substituir o conjunto freio
ASPERSOR NÃO EXECUTA A REVERSÃO (veja: 1, 2, 4, 5, 6, 7)	4 Pressão insuficiente	Elevar a pressão
	5 Balancim travado	Desmontar e liberar o balancim
	6 Mola do setor danificada	Substituir a mola do setor
	7 Anel do setor fora de seu alojamento	Posicionar corretamente o anel do setor

Never service the gun while in operation.

Niemals während des Betriebes Einstellungen/Wartungen am Regner durchführen.

Non eseguire operazioni sull'apparecchio in funzione.

Ne pas faire des interventions sur le canon en marche.

Nunca efectuar trabajos sobre el cañon en marcha.

Nunca execute operações com o canhão em marcha.

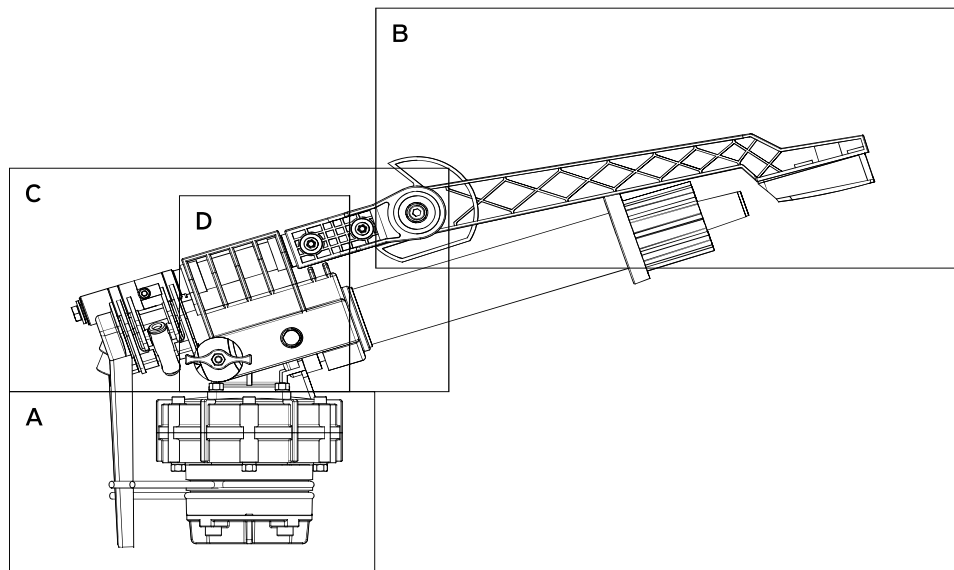

INSTRUCTIONS:

1. All moving parts have to be free.
2. When greasing, use a soft water resistant grease brand.
3. The brake surfaces should never come in contact with grease.
4. If parts have to be replaced, use the Assemblies or Kits as shown in the spare parts list, this assures a simple and complete service. For replacement follow the sequence as shown below.
5. For trouble shooting it is advantageous to have the spare parts list on hand.

ANLEITUNG:

1. Alle Bewegungen müssen frei und leichtgängig sein.
2. Zum Fetten, ein weiches, wasserfestes Fett verwenden.
3. Die Bremsscheiben dürfen niemals mit Fett in Berührung kommen.
4. Beim Austauschen von Teilen sich der Teile-Sätze wie aus der Ersatzteil-Liste hervorgeht (fett gedruckt) bedienen, dadurch ist eine einfache und umfassende Erneuerung gewährleistet. Für den Zusammenbau, die abgebildeten Sequenzen zur Demontage in umgekehrter Reihenfolge ausführen.
5. Bei der Fehlersuche ist es vorteilhaft, die dem Regner beigelegte Ersatzteil-Liste zur Hand zu haben.

ISTRUZIONI:

1. Tutti i movimenti devono essere liberi.
2. Per ingrassare usare un grasso di marca, morbido e resistente all'acqua.
3. Le pastiglie freno non devono venire assolutamente a contatto con grasso.
4. Nella sostituzione di particolari, servirsi del Kit ricambio preconfezionati come indicati nella lista ricambi (neretto), questo assicura una semplice e completo ripristino. Per il montaggio seguire a ritroso le sequenze di smontaggio illustrate.
5. Per la ricerca guasti è utile avere a disposizione la lista ricambi in dotazione all'apparecchio.

INSTRUCTIONS:

1. Toutes les parties articulées doivent se mouvoir librement.
2. Pour graisser, utiliser une bonne graisse molle, résistante à l'eau.
3. Les pastilles frein ne doivent jamais entrer en contact avec la graisse.
4. S'il faut remplacer des pièces, utiliser les kits de rechange tout prêts, indiqués en gras sur la liste des pièces de rechange, ceci garantit une manutention complète et simple. Pour le montage, suivre à rebours les séquences de démontage illustrées.
5. Pour la recherche des pannes, nous conseillons d'avoir à portée de la main la liste des pièces de rechange fournie avec l'arroseur.

INSTRUCCIONES:

1. Todos los movimientos deben ser libres.
2. Para un correcto mantenimiento, usar grasa de calidad de poca densidad (fluida).
3. Las pastillas de freno no deben estar nunca en contacto con grasa.
4. Si debe cambiarse alguna pieza, utilizar los kits de recambios confeccionados que figuran en el catálogo piezas, lo cual garantiza una sencilla y completa reparación. Para el montaje, ver esquemas adjuntos.
5. Para la busca de los desperfectos, aconsejase de tener al alcance de la mano la lista de recambios facilitada con el aspersor.

INSTRUÇÕES:

1. Todos os movimentos devem estar livres.
2. Para lubrificação, usar somente graxa de baixa densidade (fluida) e resistente à água.
3. As pastilhas do freio jamais deverão entrar em contacto com a graxa.
4. Se houver necessidade de reposição de peças, utilizar os conjuntos apresentados no catálogo de peças, esse procedimento garante uma manutenção simples e completa. Seguir os procedimentos de montagem e desmontagem apresentados a seguir.
5. Para a identificação de defeitos, é recomendável manter-se a lista de peças de reposição à mão.



A

Bearing
Hauptlager
Corpo Cuscinetto
Corps Roulement
Cuerpo Cojinete
Conjunto Rolamento

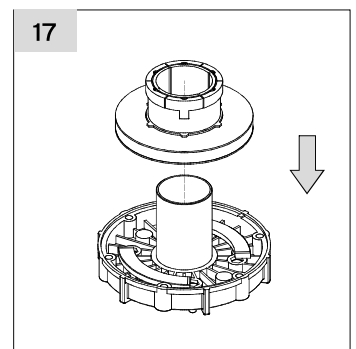
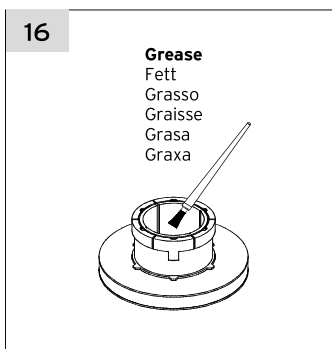
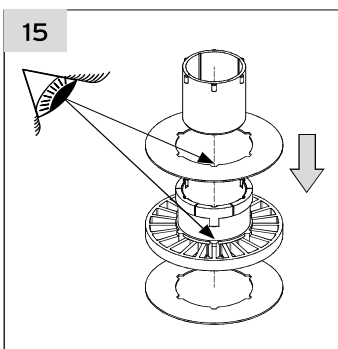
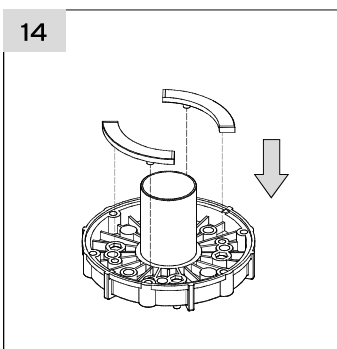
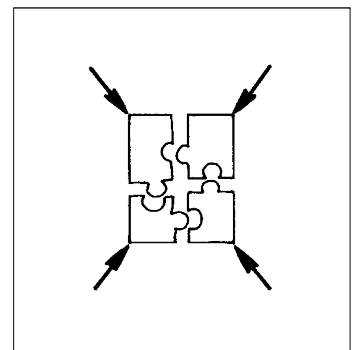
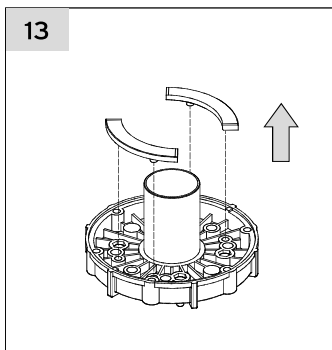
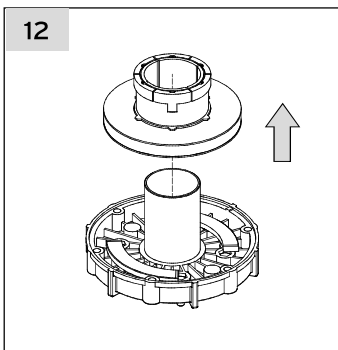
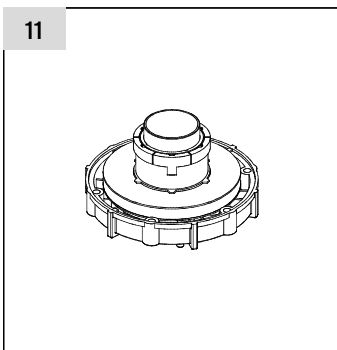
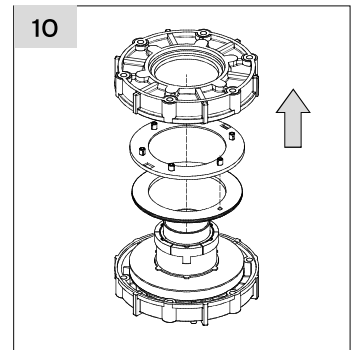
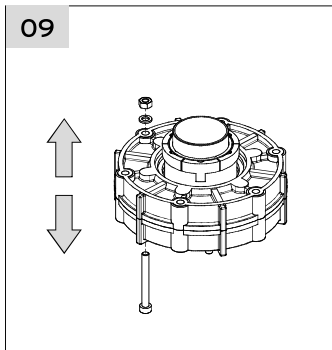
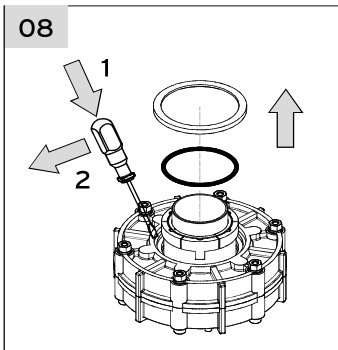
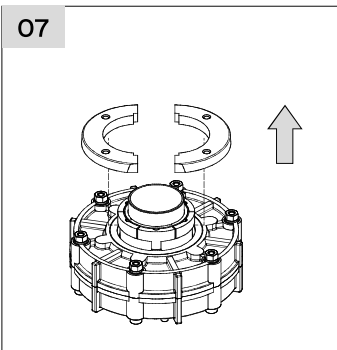
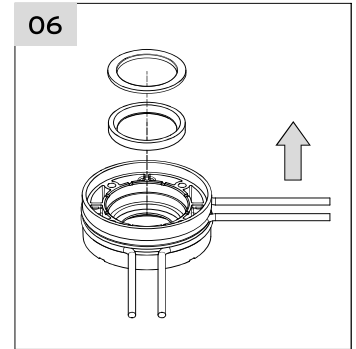
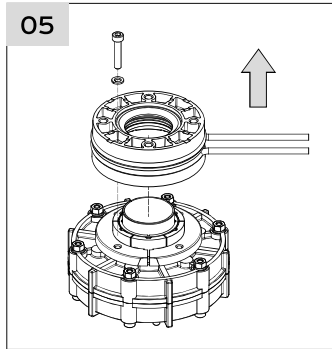
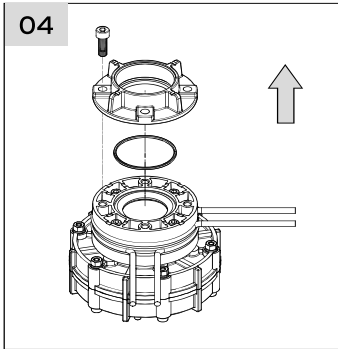
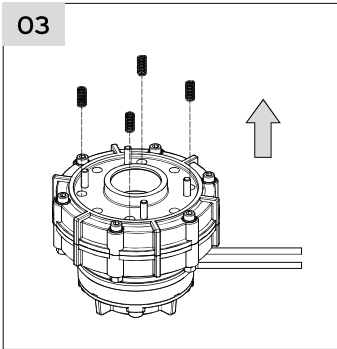
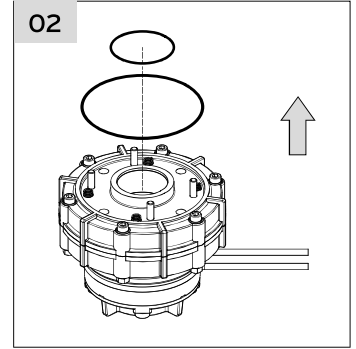
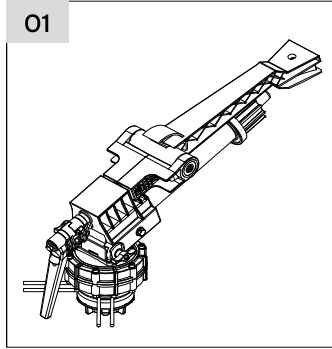
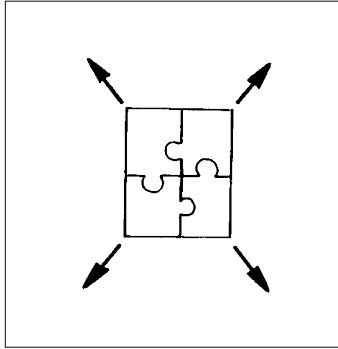

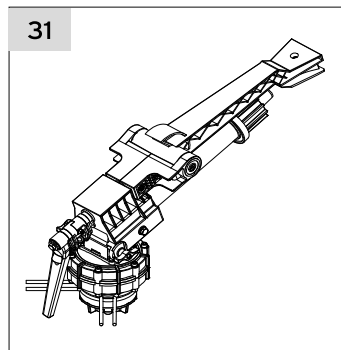
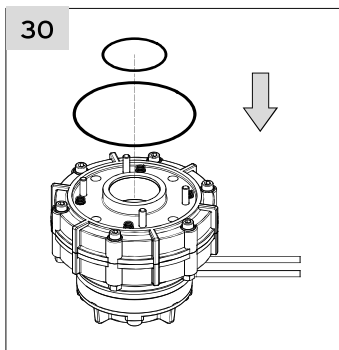
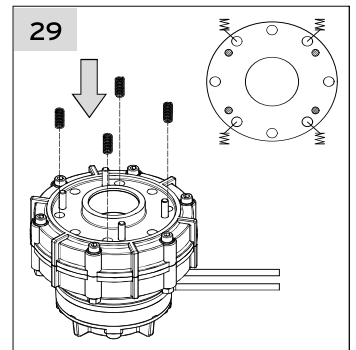
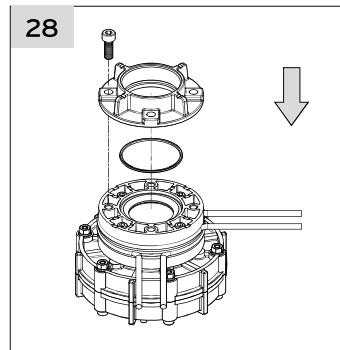
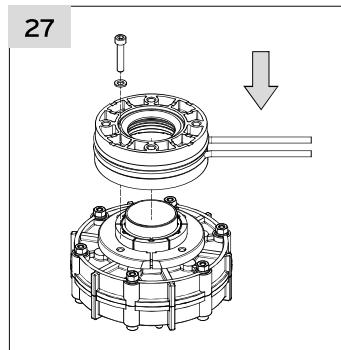
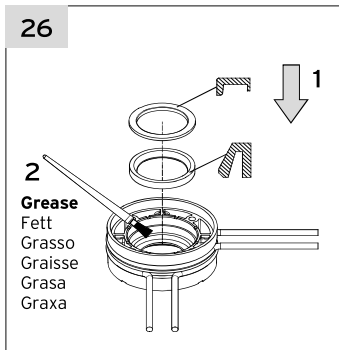
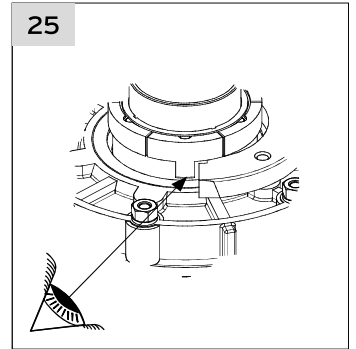
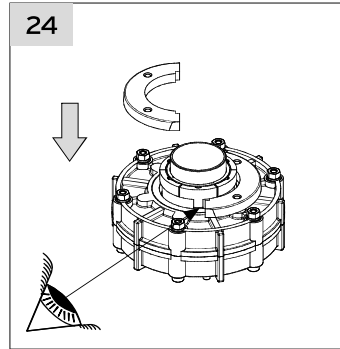
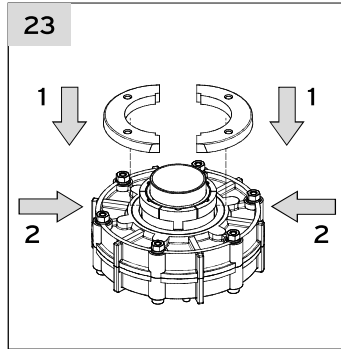
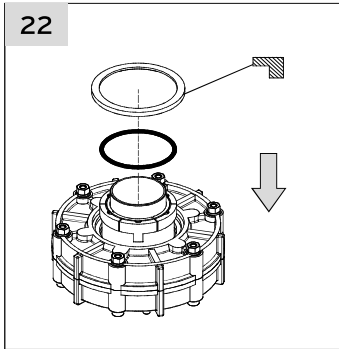
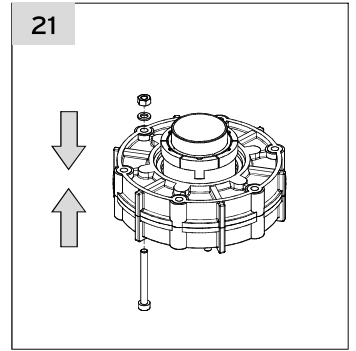
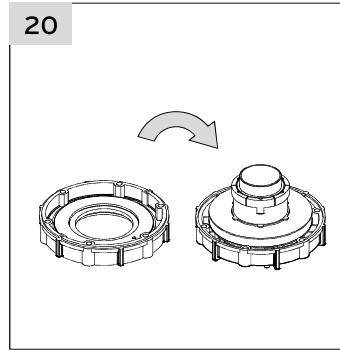
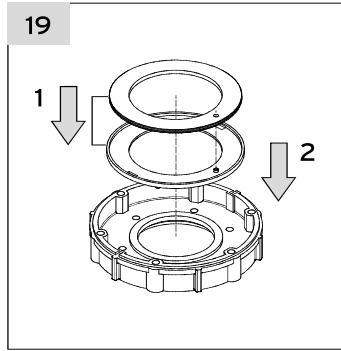
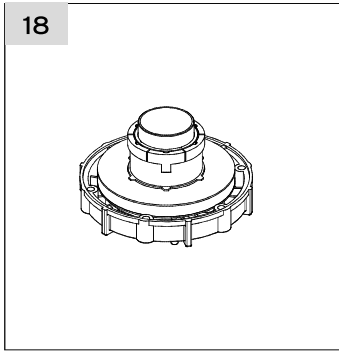

B

Drive arm
Schwingarm
Braccio oscillante
Bras oscillant
Brazo oscilante
Balancim

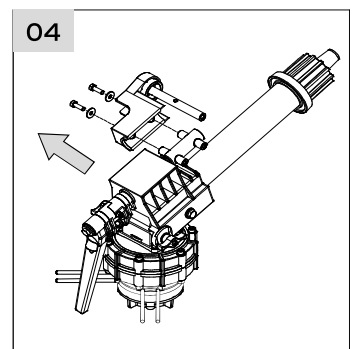
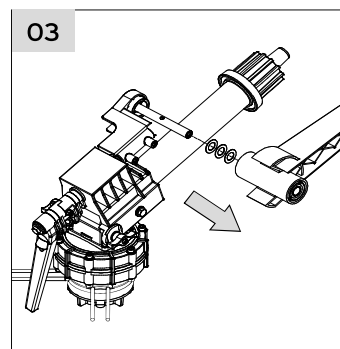
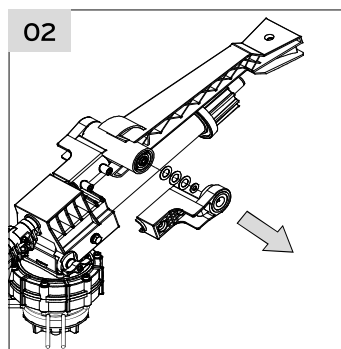
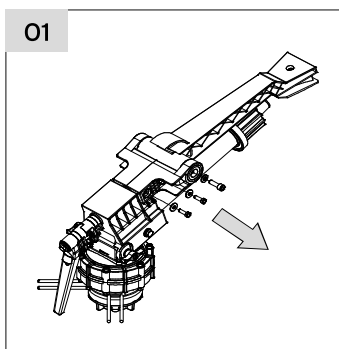
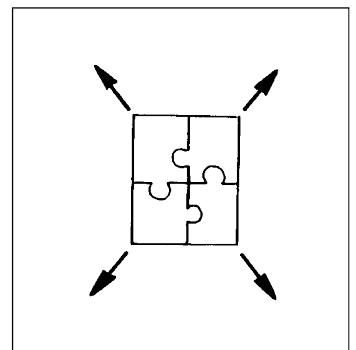

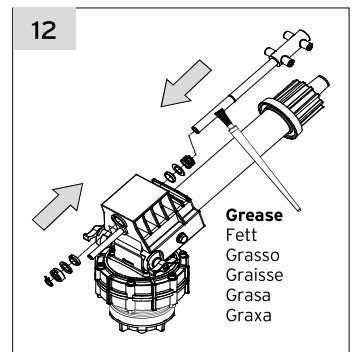
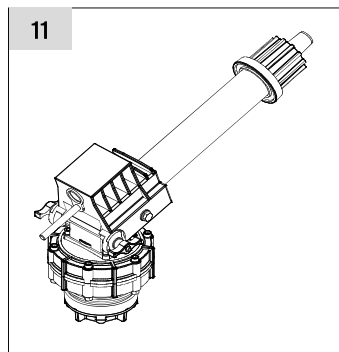
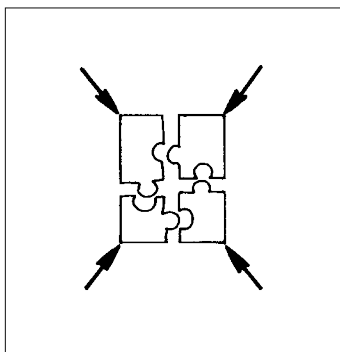
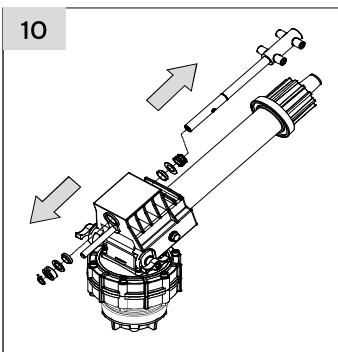
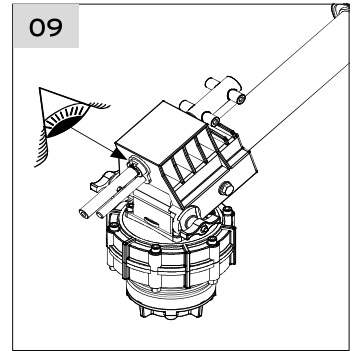
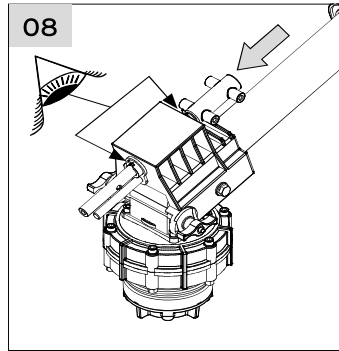
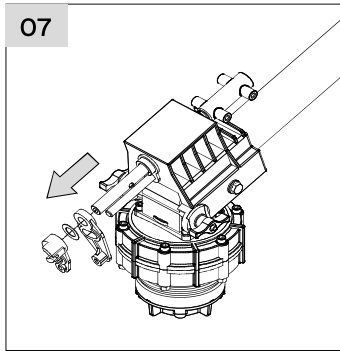
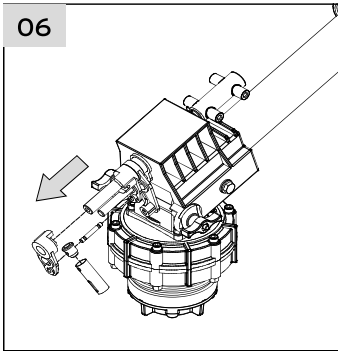
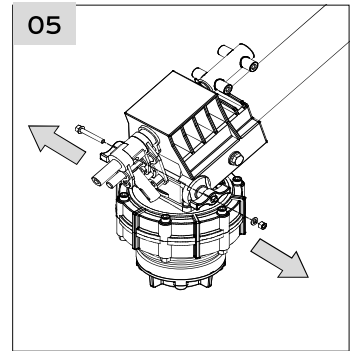
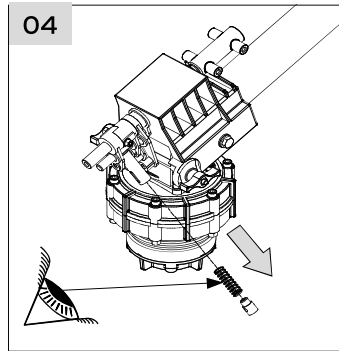
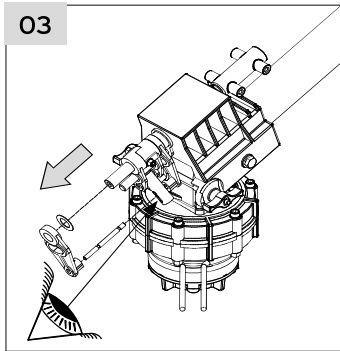
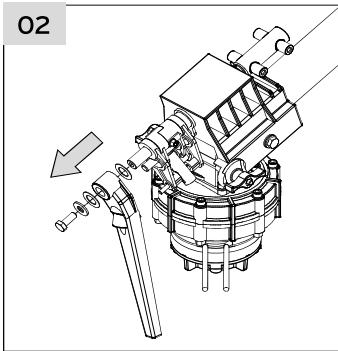
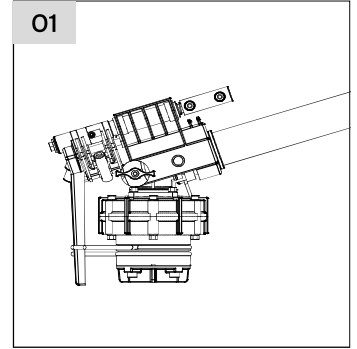
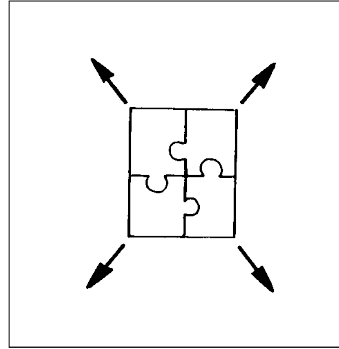
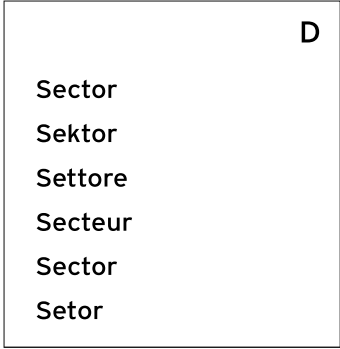
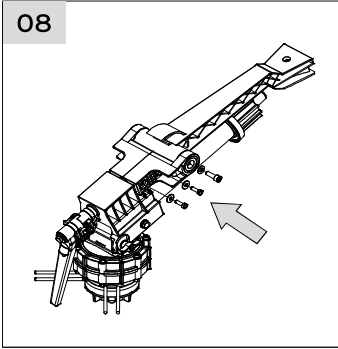
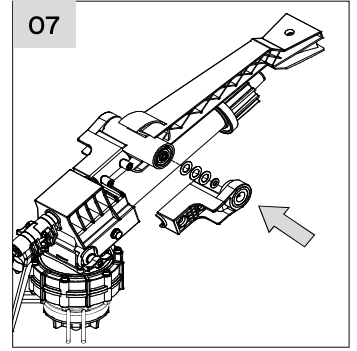
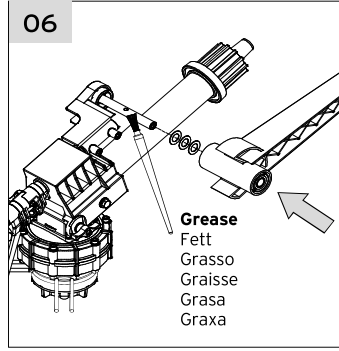
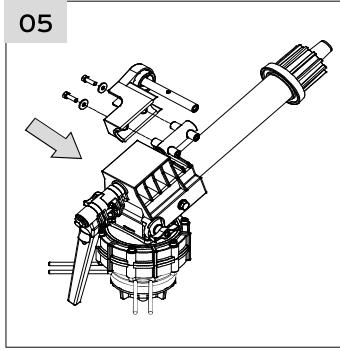
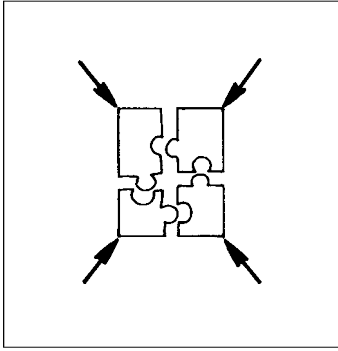

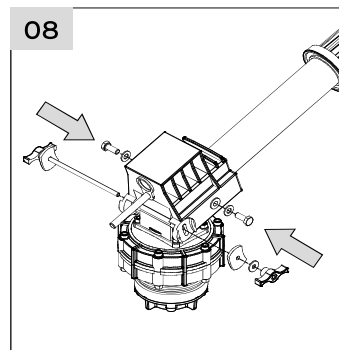
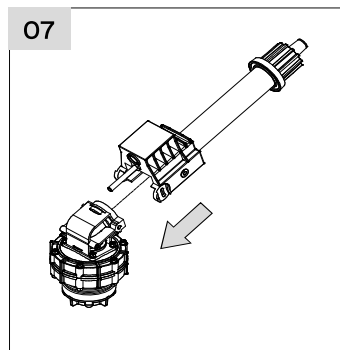
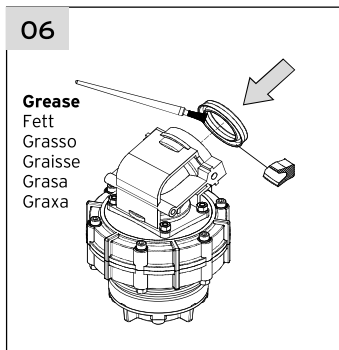
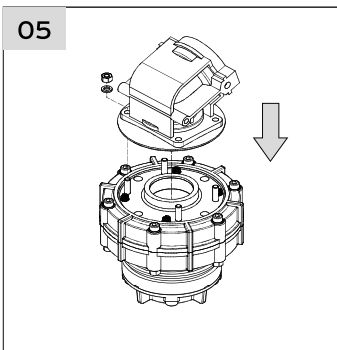
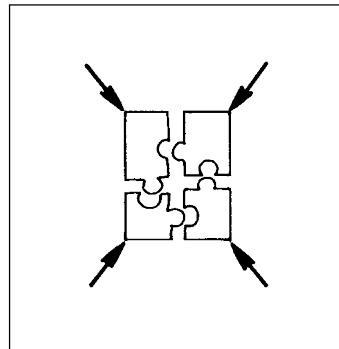
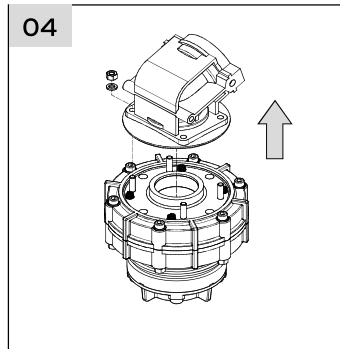
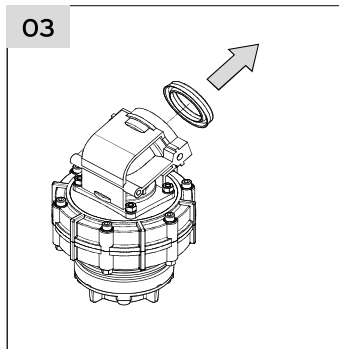
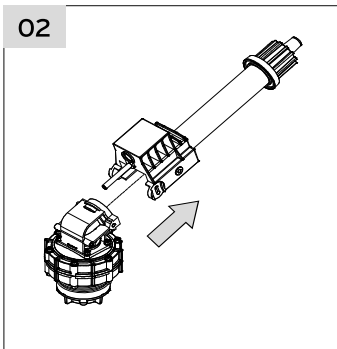
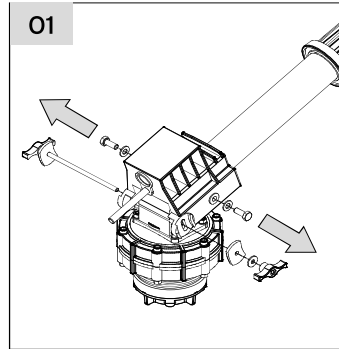
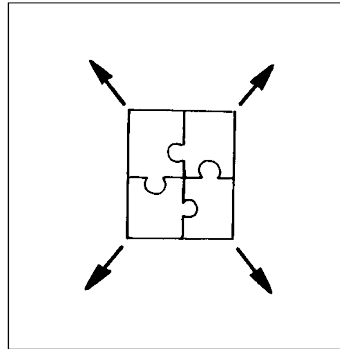
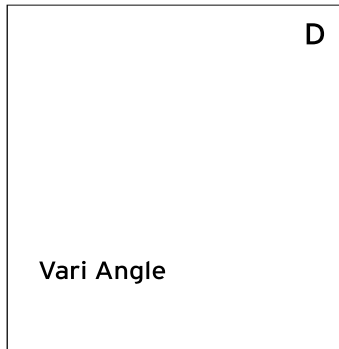
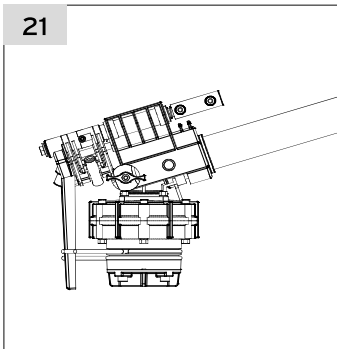
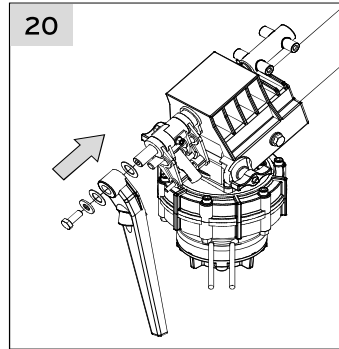
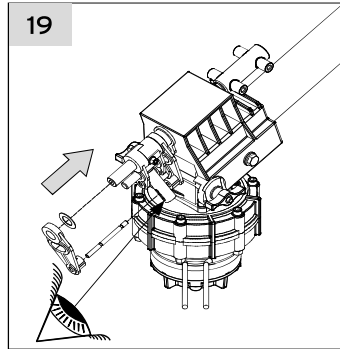
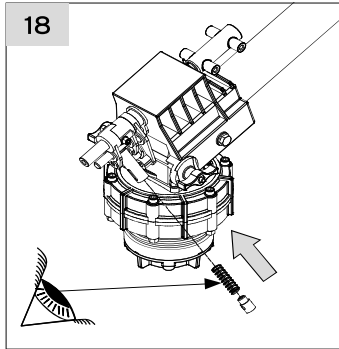
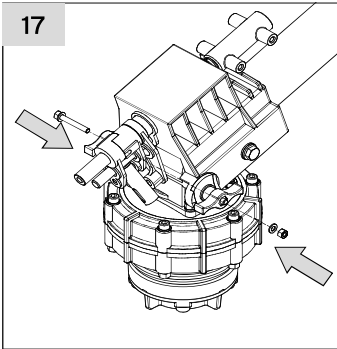
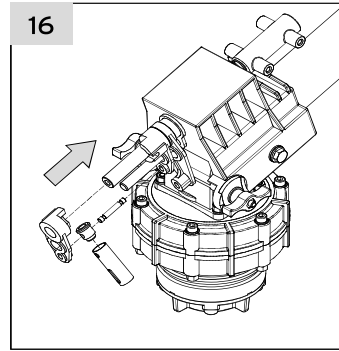
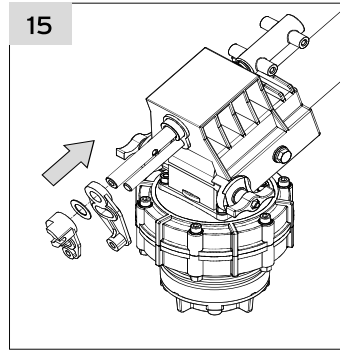
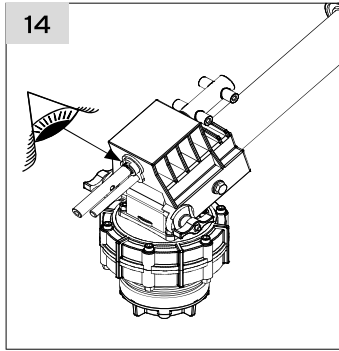
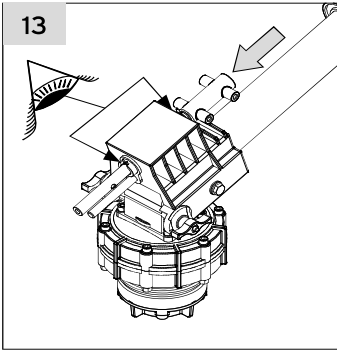

A

Bearing
Hauptlager
Corpo Cuscinetto
Corps Roulement
Cuerpo Cojinete
Conjunto Rolamento

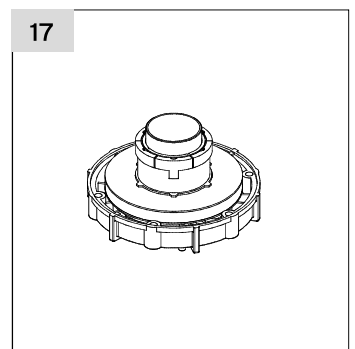
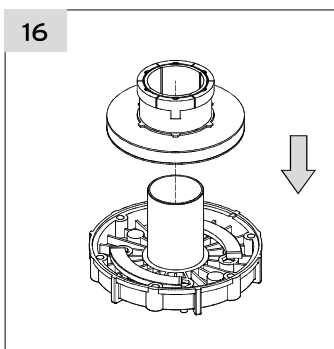
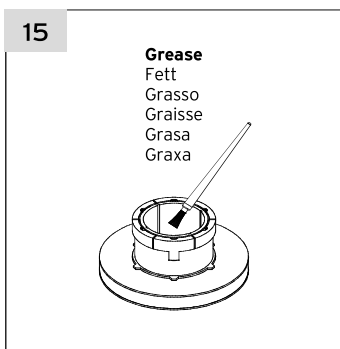
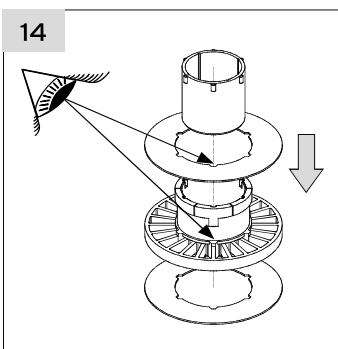
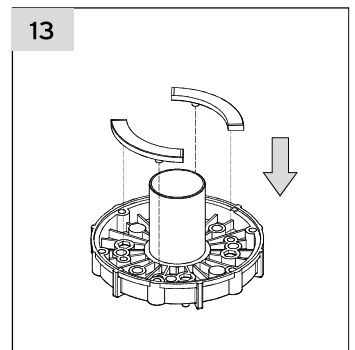
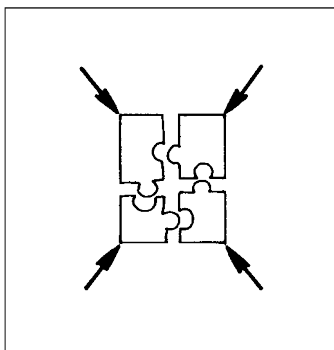
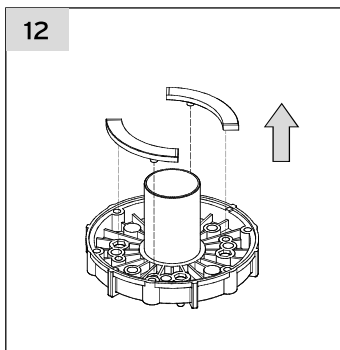
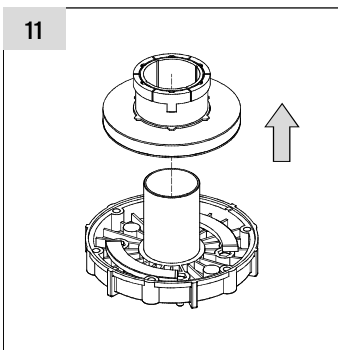
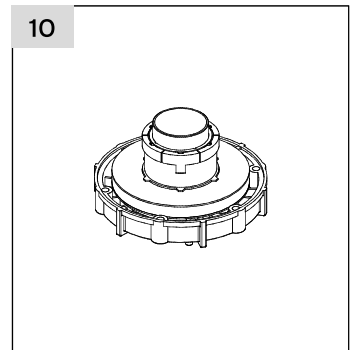
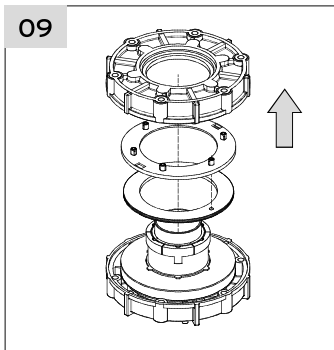
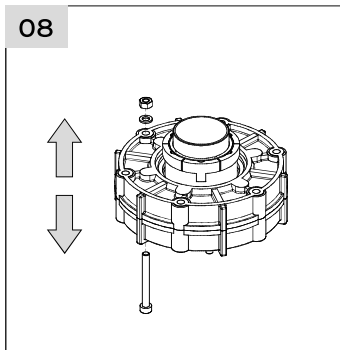
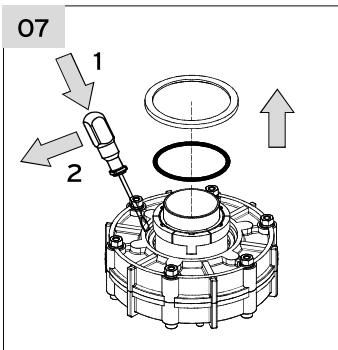
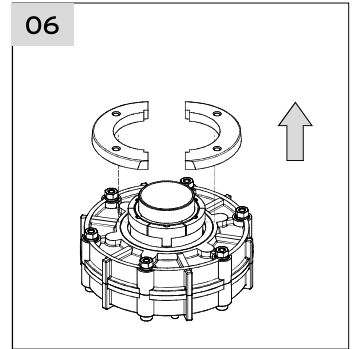
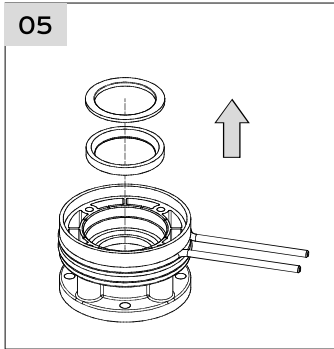
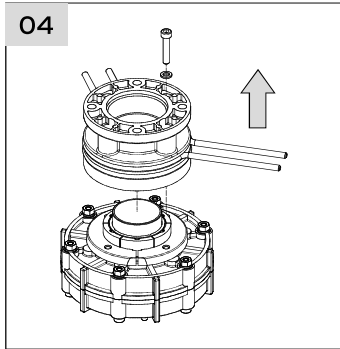
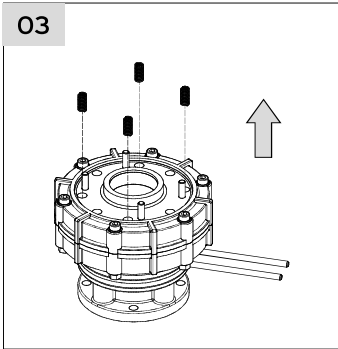
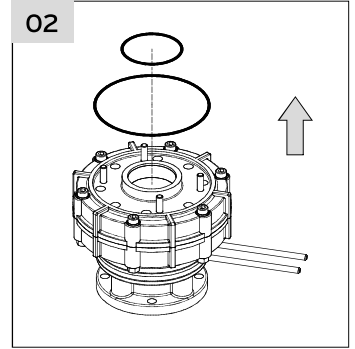
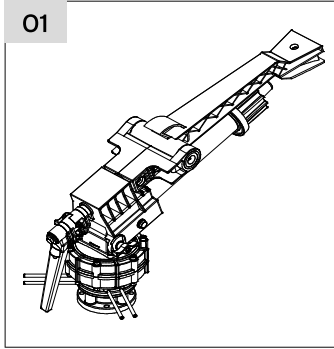
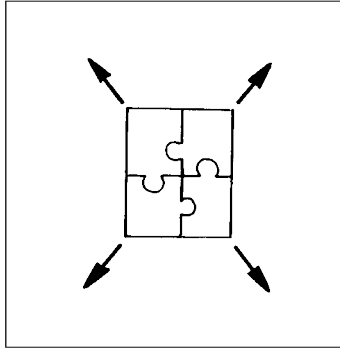

Grease
Fett
Grasso
Graisse
Grasa
Graxa

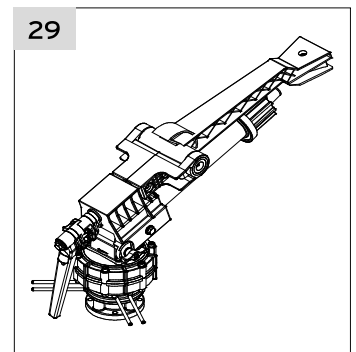
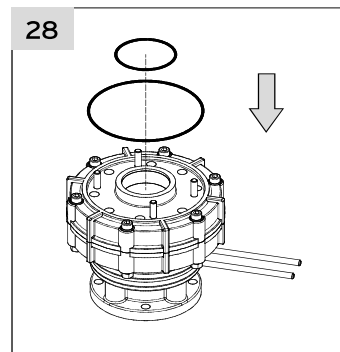
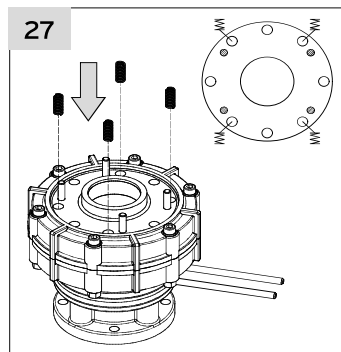
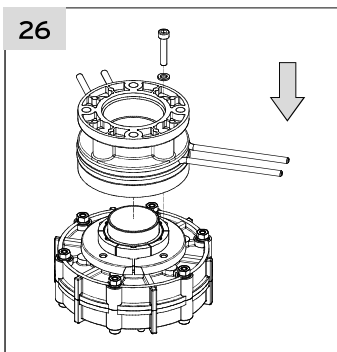
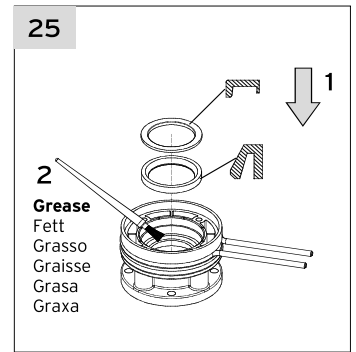
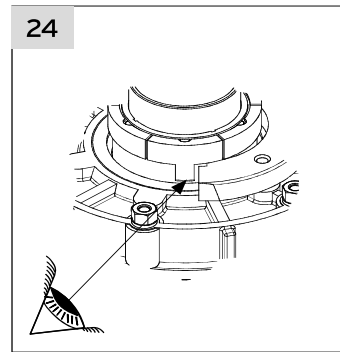
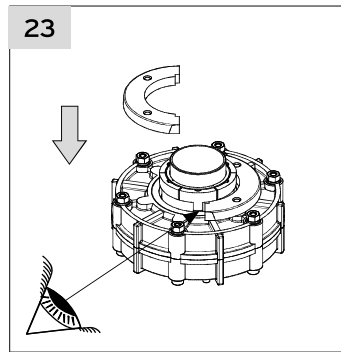
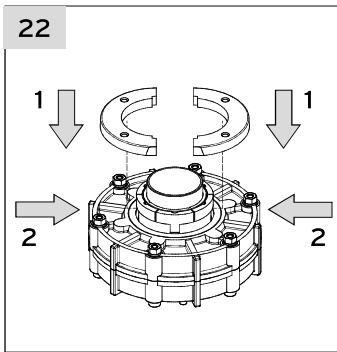
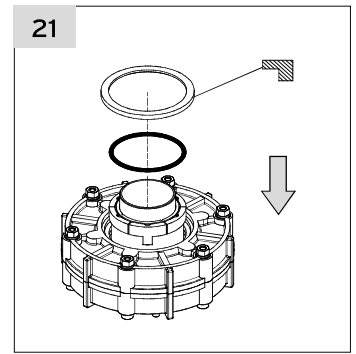
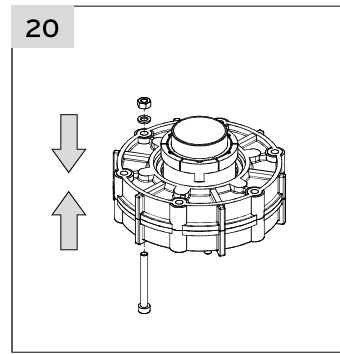
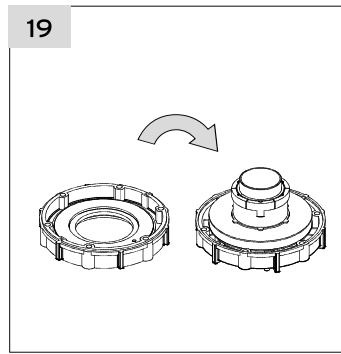
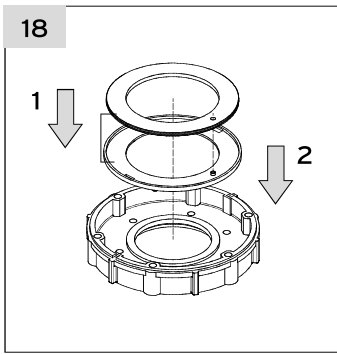

B

Drive arm
Schwingarm
Braccio oscillante
Bras oscillant
Brazo oscilante
Balancim

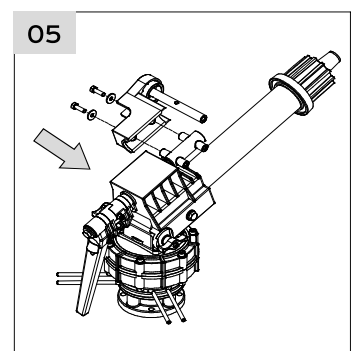
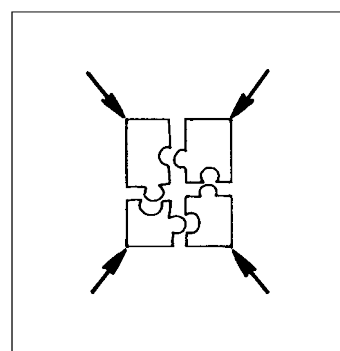
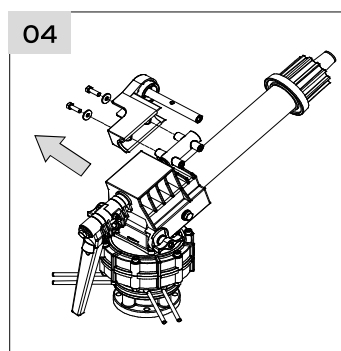
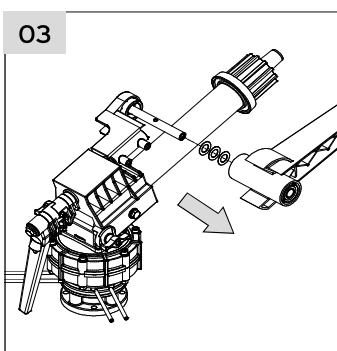
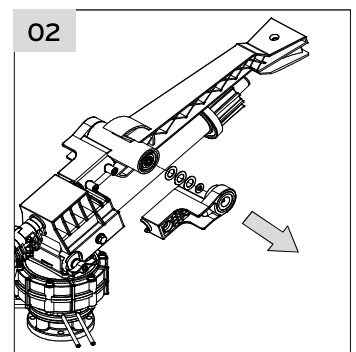
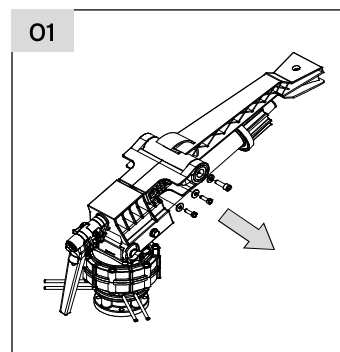
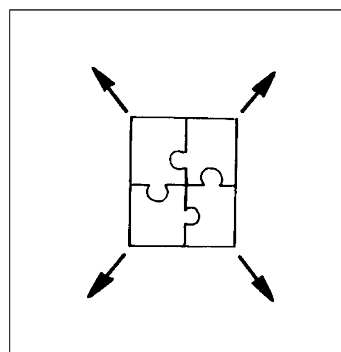

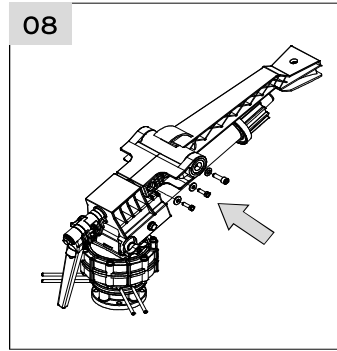
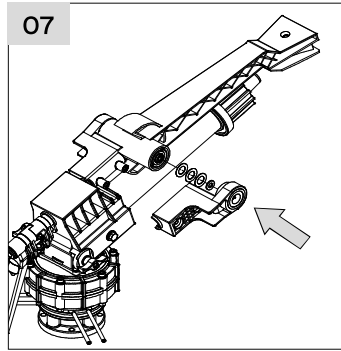
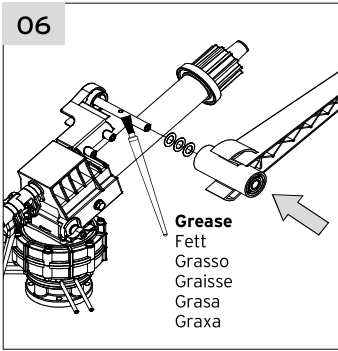

D

Sector
Sektor
Settore
Secteur
Sector
Setor

