



Vincotech



DRIVING INNOVATION IN MOTION CONTROL APPLICATIONS

EMPOWERING YOUR IDEAS



Driving innovation in motion control applications

Michele Portico, Sr. Product Marketing Manager, Vincotech

1 Motion control technology

Electric motors power the world around us. Look closely, and you'll find them everywhere, from domestic appliances such as washing machines and refrigerators to vehicles like cars, trains, and airplanes, providing countless modern conveniences. Invented in the 19th century by Werner von Siemens, Thomas Alva Edison, Nikola Tesla, and George Westinghouse – pioneering founders of their time who have since become household names – they remain at the forefront of innovation.

As a result, motion control has become a major part of modern industrial machine design. It involves carefully designing motors and incorporating control elements to ensure that motors move precisely how and when required by an application. Today, innovation in motion control technology focuses on improving performance and ease of use, as well as enabling new servo and motion control applications.

As a market leader in designing and manufacturing power electronics solutions that support motion control strategies for industrial applications, Vincotech caters to today's most important motion control use cases: industrial motor drives, embedded drives, heat pumps, HVAC systems, elevator and servo drives. In this article, we dissect each of these use cases and show how Vincotech's extensive product portfolio helps system engineers mitigate risks associated with circuit design and speed up time to market.

2 Industrial motor drives

The operating speeds and torques of industrial motors vary considerably across applications. Variable frequency drives (VFD), placed between the power grid and the motor, offer an efficient way to control motors to meet application-specific requirements (*Figure 1*). These solutions have become increasingly popular in industrial applications because they deliver short payback periods thanks to energy and cost savings.



Figure 1: Variable frequency drive (VFD)

To highlight the benefits of variable frequency motor drives, consider an application requiring precise control of *flow* velocity or pressure. Traditionally, this type of application would use valves, dampers, or gearboxes for regulation while operating a motor driven pump at full throttle. However, operating fixed-frequency grid-driven motors at full power leads to a significant portion of energy being lost as heat.

Variable frequency drives avoid these losses by adapting the motor's speed and torque to the load or required work. Two parameters enable this adjustment: the voltage frequency, which sets the motor's speed, and the supported current, which determines its torque.

Figure 2 depicts the typical energy conversion process from a fixed AC voltage to a variable AC voltage:

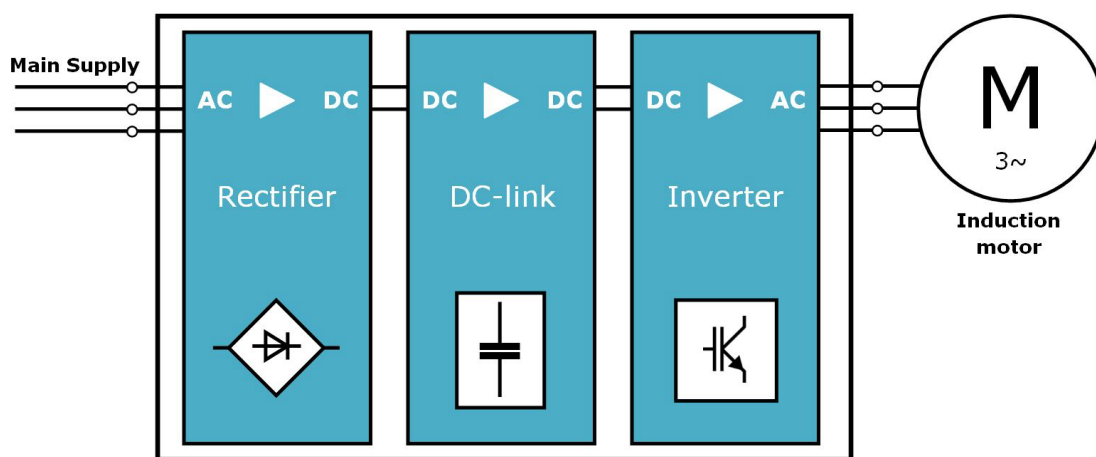

Figure 2: Energy conversion process using a variable frequency drive



The primary benefit of using a VFD is the ability to adjust a motor's speed to the needs of the entire application. Second is its ability to adjust the motor's torque, protecting the motor and the system it drives. Torque control can also translate to considerable power savings: A VFD-driven motor connected to a fan, for example, uses just one-eighth of its rated power because of the system's cube root speed-to-power relationship.

VFDs are not only relied on to accelerate motors, but also to stop or decelerate them in a controlled manner. Such controlled stopping or braking is vital for various applications such as elevators and conveyors. VFDs reverse their mode of operation without the need to reconfigure motor phase cables, simply by inverting the rotary field. By eliminating valves, dampers, and gear boxes, they enable the development of more compact systems with reduced maintenance and operation costs.

VFDs comprise three key components: a power rectifier used to rectify the AC input voltage; a brake chopper to protect the DC-link capacitor by dissipating energy generated by the motor during braking; and power semiconductor switches used to convert the rectified input voltage to the required variable voltage and frequency output.

Vincotech's offering for variable frequency drives include power integrated modules (PIM/CIB – converter, inverter, and brake), sixpacks (three-phase modules), half-bridges, and rectifier modules designed for standard industrial drive applications with power ranges from 1-60 kW.

3 Embedded drives

Embedded drives, which integrate the motor drive and the electric motor into a single unit, are gaining market share in industrial applications. Many suppliers offer embedded drive systems with varying degrees of customization. In addition to allowing customers to save space thanks to their compact, hermetic design, embedded drives can be tailored to specific applications to increase reliability and performance and, crucially, reduce cost.

Embedded drives comprise an input rectifier, a PFC boost stage, and a three-phase output inverter. Depending on the application, they can be implemented using a highly integrated intelligent power module (IPM) or a very flexible power integrated module (PIM). While IPMs include the logic components and gate drives required by power switches, PIMs only provide the power components, requiring the gate drives to be mounted on the system's PCB (*Figure 3*).

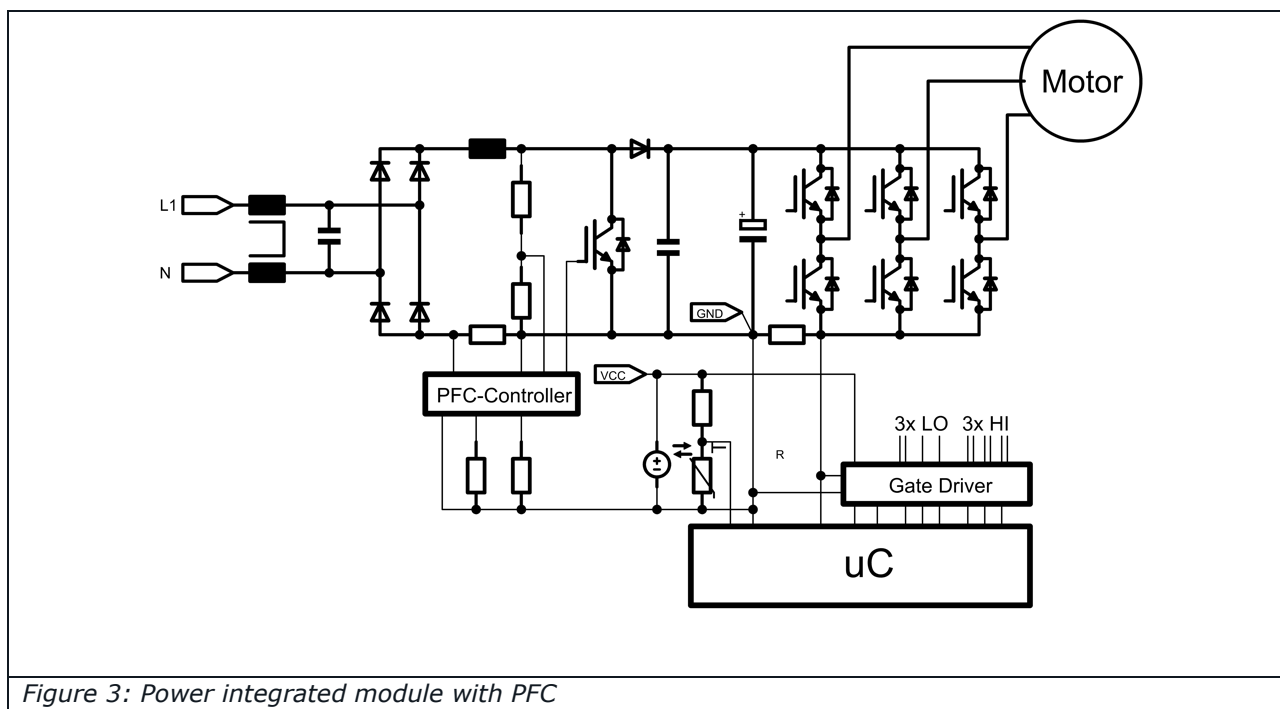

Figure 3: Power integrated module with PFC

Electronically controlled motors embedded in pumps, compressors, fans, and similar applications must fulfill two key requirements:

- Hermetic sealing: These motors require a hermetically sealed enclosure with a compact design and meticulous thermal management, as heat generated by gate drives, shunt resistors, and other resistive components can only be dissipated via a connected heat sink.
- Power correction factor (PFC): When these motors connect to the public power grid, the drives must incorporate power factor correction (PFC) to comply with regulatory standards.

To optimize the overall cost, size, and time to market of embedded drive solutions, system designers can integrate most functional blocks used by the motor drive, excluding the input filter, DC capacitor, and microcontroller, using an intelligent power module (IPM). This approach mitigates risks associated with circuit design, speeds up development, and cuts time to market. While standard IPMs feature a simple three-phase inverter bridge with a compatible gate driver, highly integrated modules allow engineers to optimally combine power components and the gate drive circuit – critical elements in the inverter’s design.

Vincotech’s power module portfolio for embedded drives features 600 V and 1200 V intelligent power modules (IPMs) and power integrated modules with PFC circuits (PIM+PFC). With the



highest level of integration of any power module available today, these modules offer the best solution for space-constrained mechanical environments.

Vincotech's *flowIPM* 1B and *flowIPM* 1C maximize their functional integration by integrating power semiconductors, integrated circuits, SMDs, and resistors into their substrate using thick-film technology (Figure 4). Their design integrates all active power components required for a three-phase inverter with active power factor correction (APFC). Components include capacitors to compensate inductive loops, shunts to sense current, a PFC controller and circuitry to divide the voltage, and DC capacitors. Two external resistors set the module's output voltage and PFC frequency.

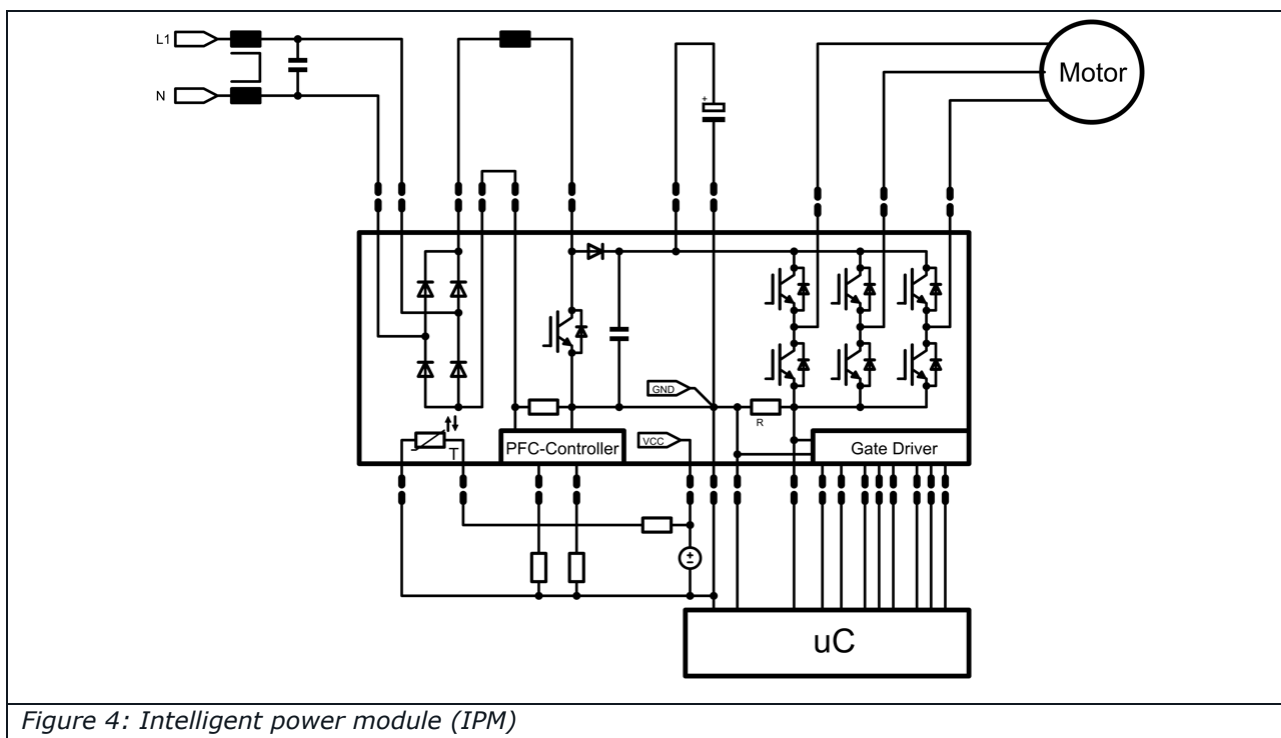

Figure 4: Intelligent power module (IPM)

Customers using the external microprocessor for the inverter to control the PFC can opt for a version of the module featuring only the PFC switch gate driver. In this case, they may have to include a negative supply and an amplifier for the PFC current signal. The microcontroller's ground connection is located on the positive side of the PFC shunt resistor (a direct connection to the microcontroller being impossible).

The optional Press-fit interconnection further increases engineers' leeway in designing their target applications. Moreover, by leveraging the module's functional integration, drive manufacturers effectively offload R&D efforts to the module manufacturer, reducing development efforts while enjoying greater flexibility in defining functions and calibrating



switching behaviour. This flexibility is critical, as the filtering effort and switching losses of applications operating at 4 kHz PWM and 16 kHz need to be optimized differently.

PIM modules only include the power components – the input rectifier, PFC boost stage, and three-phase output inverter. The gate drive circuit and additional logic circuits must be included on the external PCB. However, they feature an integrated DC capacitor to reduce inductance and enable ultra-fast turn-off for the PFC switch.

Some PIM modules include a shunt resistor that senses current to control the PFC or the inverter. The open emitter structure in the low-side switches makes it possible to connect three external shunt resistors for vector control-based inverter designs. A temperature sensor provides the temperature of the heat sink adjacent to the module.

4 Heat pumps and HVAC

Increasing power density is a primary objective of heat pump and HVAC design. There are several ways to achieve this.

- Adopting more compact designs
- Increasing energy conversion efficiency
- Integrating cost-effective solutions

With its power-integrated module featuring an interleaved power factor correction circuit, Vincotech offers a unique and innovative topology for power modules with a high level of integration and improved energy conversion efficiency.

The interleaved configuration of the PFC circuit offers numerous benefits:

- Simplified PCB design
- Increased energy conversion efficiency
- Improved heat distribution
- Reduced component size on the PCB
- Simplified EMI filtering design
- Reduced output RMS current

Vincotech's new 600 V *flowPIM* + PFC family includes four sub-families. These include a two-leg interleaved PFC circuit with and without an integrated input rectifier, and a three-leg interleaved PFC without an input rectifier. The offering further includes products based on the



bridgeless totem pole interleaved PFC, also integrating the inverter stage (Figure 5). All variants feature a three-phase motor inverter and a temperature sensor.

The variants with a two-leg interleaved PFC also include shunt resistors in the motor inverter and the PFC circuit. By perfectly balancing the current in the PFC circuit, the common and leg shunts allow to increase the chipset's operational lifetime. Meanwhile, the integrated shunt resistors in the inverter leg vastly improve motor control. Furthermore, onboard capacitors dramatically reduce DC-link voltage overshooting.

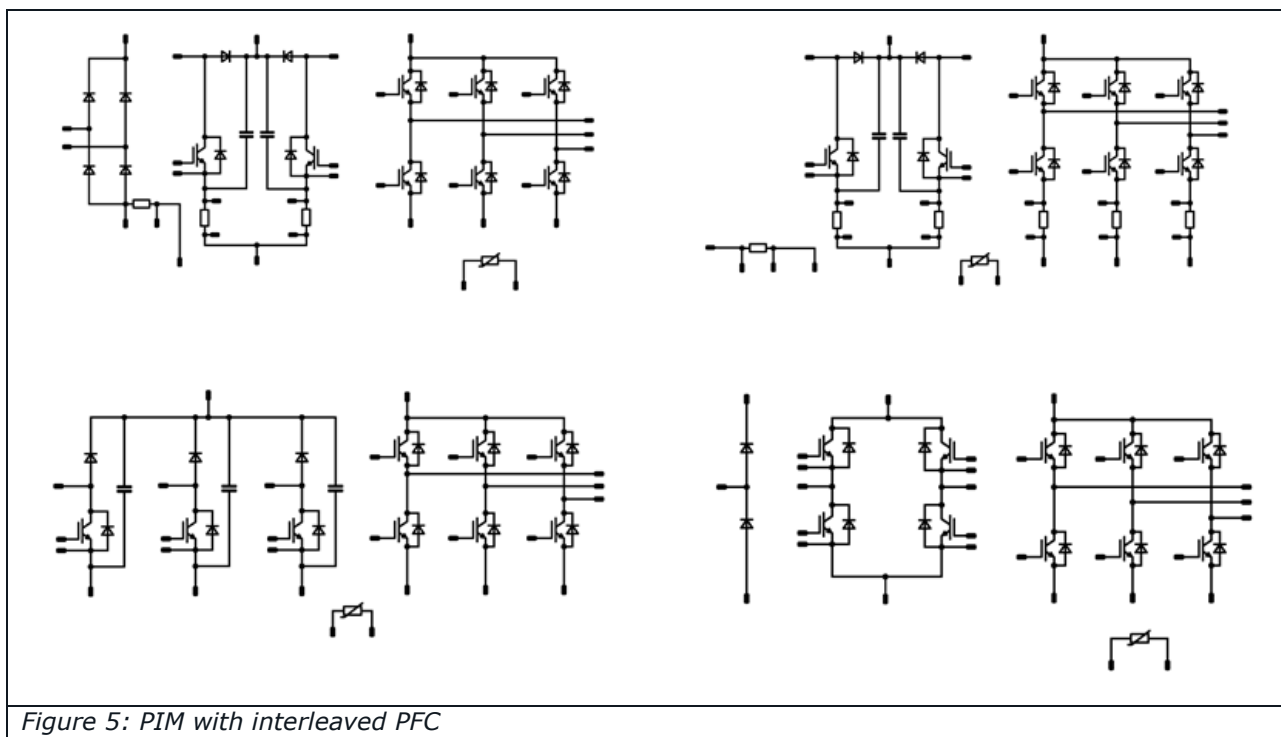

The 600 V *flowPIM* + PFC modules optimally balance cost and performance. Their power pins, located at the modules' periphery, simplify and reduce the cost of PCB design. Separating the inverter and PFC parts further optimizes their thermal performance.

5 Elevator drives

In elevator and escalator systems, the main requirements for power modules are longevity and high switching frequency in the converter stage.

Vincotech's portfolio targeting these applications is built around the standard sixpack topology as well the sixpack topology enhanced with high-speed components. It also includes dedicated topologies that reduce the solution size and meet the application requirements by integrating two sixpacks for both the converter and motor stages.

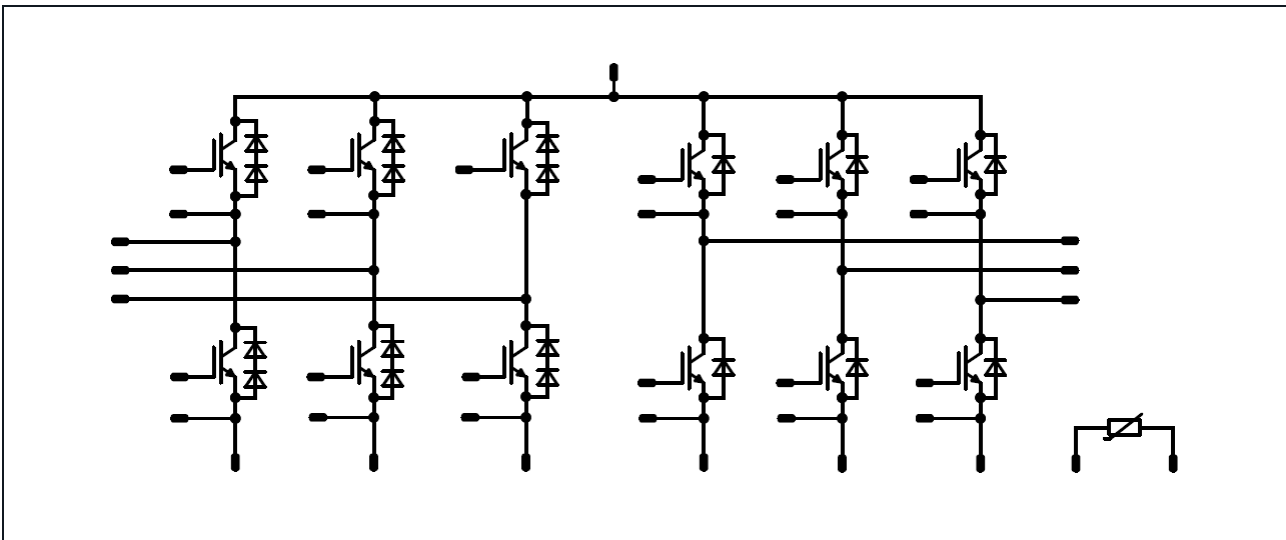

Figure 6: Twin-pack with tandem diode

These twin-pack modules, which typically include standard and high-speed components, use a tandem diode solution to reduce power losses and extend their longevity (Figure 6).

6 Servo drives

Servo drive systems typically require switching frequencies between 10-16 kHz and output current overload of up to 130% of the nominal current value.

Vincotech's comprehensive product portfolio includes input rectifier modules and sixpack power modules for the motor stage. Equipped with high-speed components, the sixpacks mitigate overall power losses when operating at high switching frequencies. Tandem diodes further reduce power losses and extend the lifecycle of the components (Figure 7).

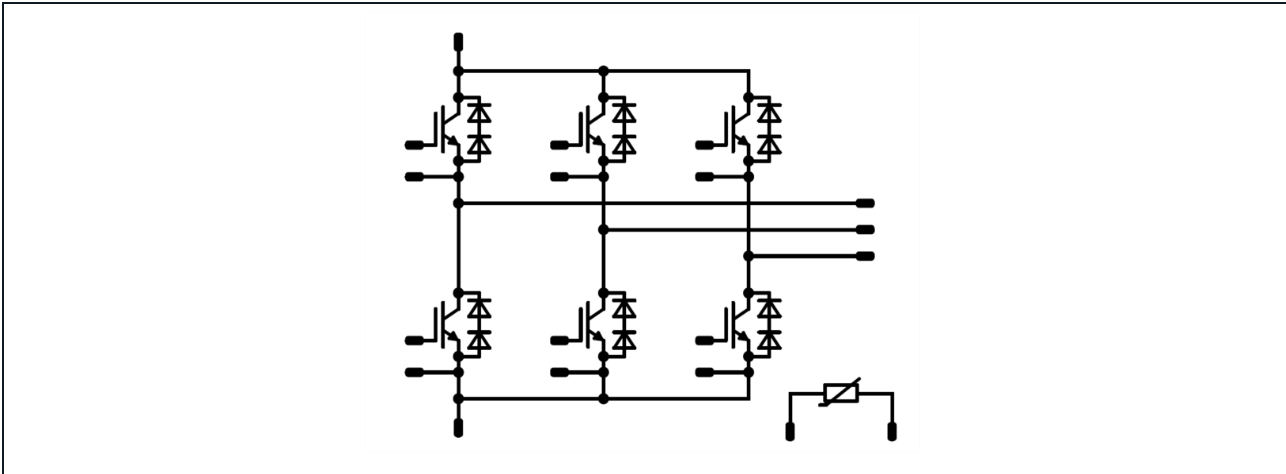

Figure 7: Sixpack with tandem diode



7 Vincotech: Your partner in motion control for industrial applications

Across the industry, electric motors are at work enabling modern life as we know it. These motors are controlled by power conversion devices that set the speed and torque of the electric motors to meet a wide range of specific application needs.

Vincotech's comprehensive product portfolio provides engineers with the functional integration and power density they need to support motion control strategies for industrial applications. Combining a high degree of integration and innovation, they enable sleeker designs harnessing a proven blend of power components and gate drive circuits – crucial components of inverter design. This mitigates design risks and expedites development, ensuring a rapid path to market.



Vincotech GmbH

Biberger Strasse 93 | 82008 Unterhaching | Germany
T +49 89 878 067-0 | F +49 89 878 067-300

www.vincotech.com

Copyright © 2024