



Vincotech

THE ADVANTAGES AND OPERATION OF FLYING CAPASITOR BOOSTER

EMPOWERING YOUR IDEAS



The advantages and operation of flying capacitor booster

Viktor Antoni, Development Engineer - Electronic Design, Vincotech

1 Introduction

High efficiency solar inverters getting more demand in the recent years. But cost-efficient solutions are also desirable. To achieve this, not only the inverter but also the Booster stage have to be low cost and highly efficient. Two-and three-level Boosters are commonly used in solar inverters. The three-level solutions can decrease the voltage stress on the semiconductors and the output voltage ripple; therefore, the inductor size can be decreased. Due to three-level operation switched voltage level are half of the DC-link voltage low voltage semiconductors can be used which are faster and cheaper. For three level operation an adequate DC-link capacitor (capacitive voltage divider) must be utilized which can split the two-level DC voltage into three voltage levels. In this case the PWM signal needs to be corrected to ensure the symmetry of the neutral point of the divider. Usually, two inductors are used in the input in three level boosters. This document describes the flying capacitor booster solution, which increase the efficiency while still cost efficient without enormous three level DC-link capacitors and with only one choke on the input.

2 The flying capacitor booster

In this topology the additional voltage levels are synthesized by capacitor, so-called flying capacitor.

In a three-level case the voltage of the flying capacitor is half of the output voltage. This capacitor can offset the output voltage with v_{DC2} in positive and negative direction. The three-level flying capacitor booster can be seen on *Figure 1*.

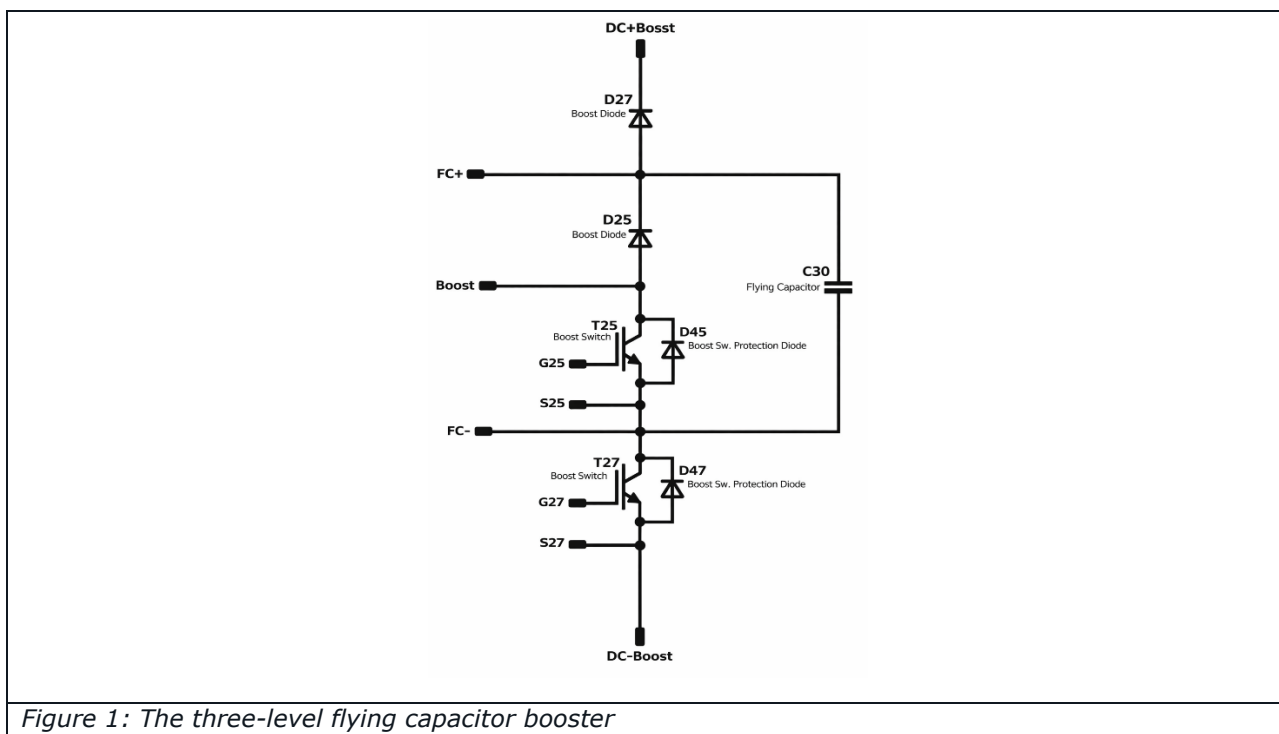

Figure 1: The three-level flying capacitor booster

In the flying capacitor booster due to the phase shift (see Chapter 2.2) in the control of transistors the input frequency is p times the switching frequency (p is the number of stages describe later).

2.1 The commutation loops and operation modes of the flying capacitor booster

In flying capacitor booster, the commutation loops are including capacitors. A capacitor from the commutation point of view can be considered zero impedance. It's main role in the commutation loop to offset the two-outer semiconductor from each other. With this offset the three-level flying capacitor booster can be considered as two standalone boosters, where the outer one's commutation loop includes the DC-link capacitor, the outer diode, the flying capacitor and the outer switch. The inner commutation loop includes the flying capacitor, the inner diode and the inner switch. The two commutation loops can be seen on *Figure 2*.

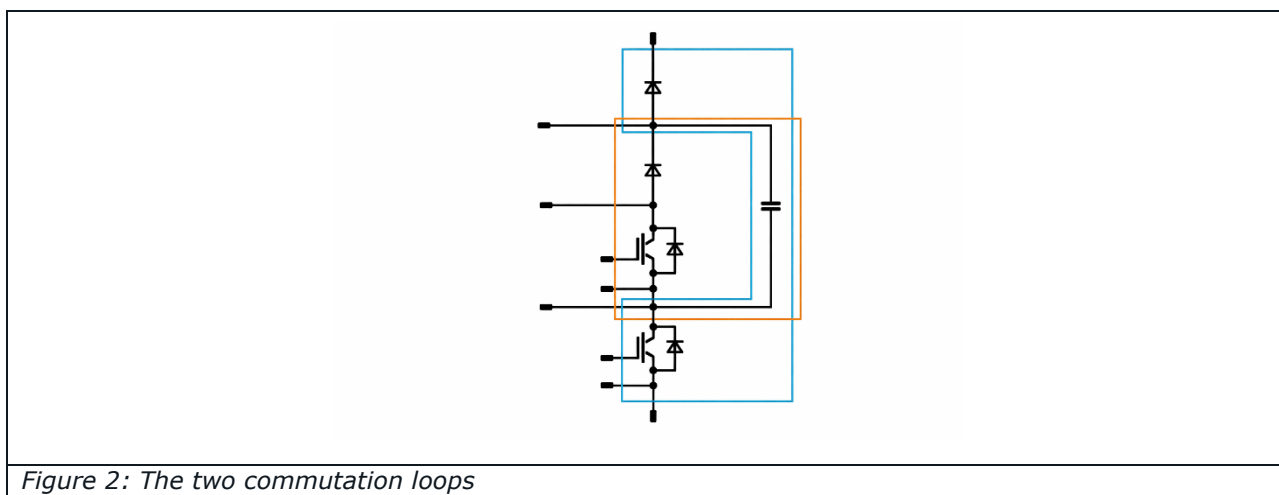

Figure 2: The two commutation loops

In general, the number of voltage levels are theoretically endless, but in practice three, four and five levels are used. The additional levels in n level solution can be realized by adding extra outer commutation loops to the three-level converter. Every added booster's commutation loop will be like the blue loop on *Figure 2*. The number of voltage levels can be calculated as the following:

$$n_{level} = p + 1$$

Where p is number of the commutation loops (boosters). The voltage of the capacitor can be calculated:

$$V_{FC,i} = V_{DC} \cdot \left(1 - \frac{i - 1}{p}\right)$$

Where i is number of the given commutation cells. The first loop refers always the most outer loop.

This article will describe the operation and behaviour of the three-level flying capacitor booster. All other solution can be realized based on this article.

In the operation of the three-level flying capacitor booster four different mode can be derived. During normal operation the voltage of the flying capacitor is the half of the output voltage and the inductor current is perpetual. In the first mode all the two switches are off, the current goes thru the two diodes, they are working in bypass mode. In this mode the voltage of the flying capacitor is not changing, the current of the choke is decreasing, the output voltage is increasing. In the second mode, the lower switch (T27) is turned on. The current is charging the flying capacitor resulting its voltage to increase. In the third mode the inner switch is



turned on (the outer switch is turned off), the current goes thru the flying capacitor, while its voltage is decreasing, the output voltage will increase. In the last mode, all the two switches are turned on. The voltage of the flying capacitor will be stationary, while the current of the choke will be increasing. In the second and the third mode the inductor current change is dependent on the duty cycle (D). The operations and their effects can be seen on *Figure 3* and *Table 1*.

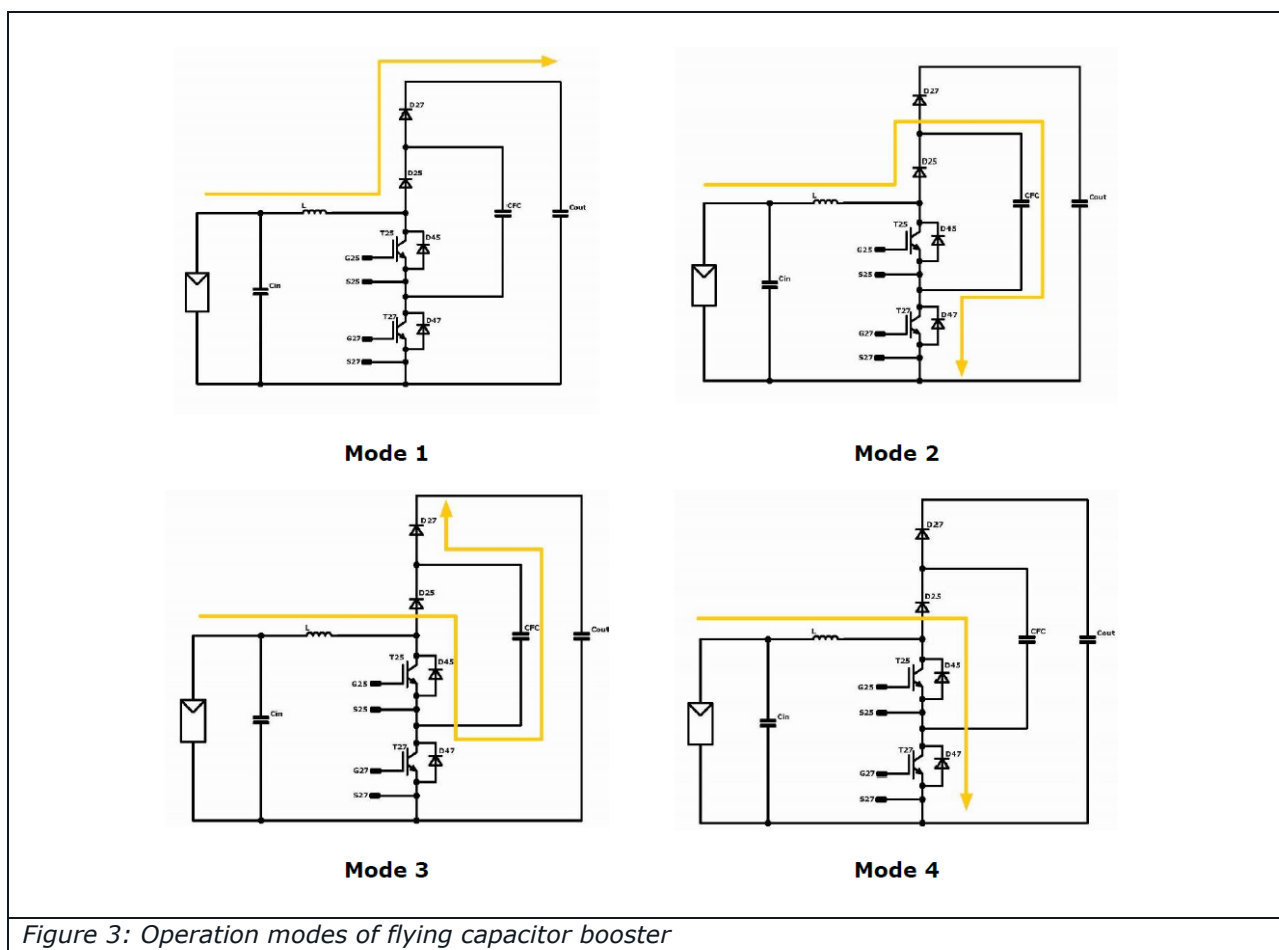

Figure 3: Operation modes of flying capacitor booster

Mode	Transistors		Inductor current		FC voltage	DC-link voltage
	T25	T27	$D < 0.5$	$D > 0.5$		
Mode 1	OFF	OFF	decreasing	-	-	increasing
Mode 2	OFF	ON	increasing	decreasing	increasing	decreasing
Mode 3	ON	OFF	increasing	decreasing	decreasing	increasing
Mode 4	ON	ON	-	increasing	-	decreasing

Table 1 Output and FC voltage states

The transfer function (y) of the flying capacitor booster is the following:

$$y = \frac{V_{OUT}}{V_{IN}} = \frac{1}{1 - D}$$

Where D is the duty cycle.

The used modes are depending on the duty cycle. If $D < 0.5$ than $y < 2$. In this case Mode 4 is not used and the operation will be the following:

... → Mode 1 → Mode 2 → Mode 1 → Mode 3 → ...

If $D > 0.5$ than $y > 2$ and the operation will be:

... → Mode 4 → Mode 2 → Mode 4 → Mode3 → ...

In case of $D = 0.5$, $y = 2$ the operation:

... → Mode 2 → Mode 3 → Mode 2 → Mode3 → ...

The most used operation when D is less than 0.5.

2.2 The operation of the flying capacitor booster

In the flying capacitor booster topology, the two transistors must be controlled by 180° C phase shifting (*Figure 4*).

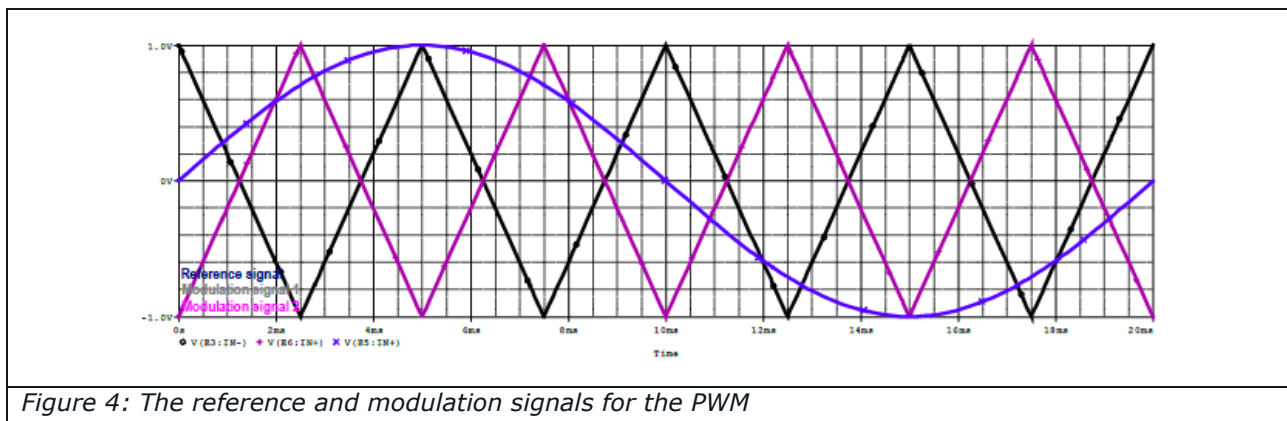

This results that in case of $D = 0.5$, the operation modes will change between Mode 2 and Mode 3. The typical curves of the flying capacitor booster can be seen on Figure 5 in case of $D = 0.2$.



a,

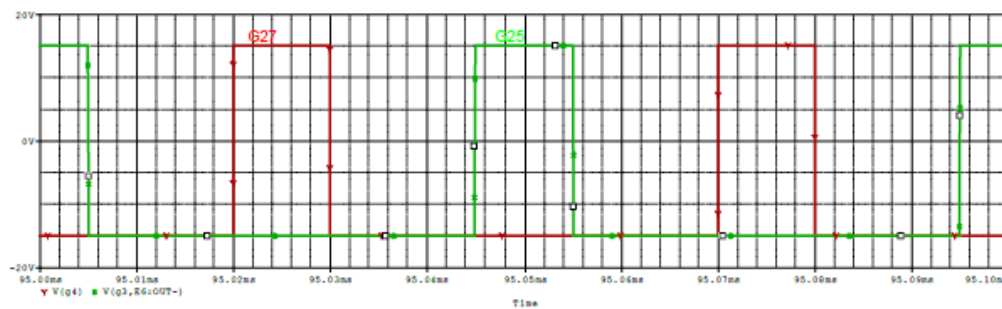

b,

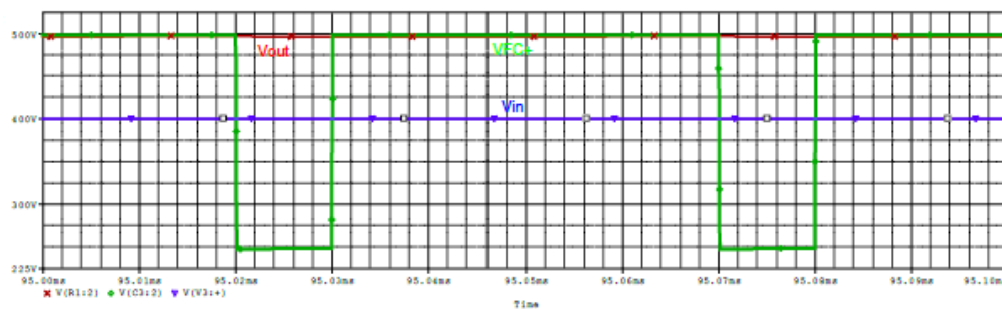

c,

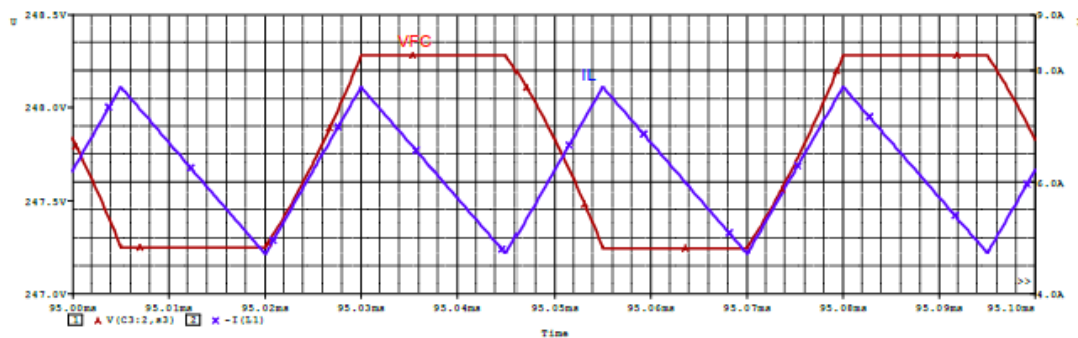

d,

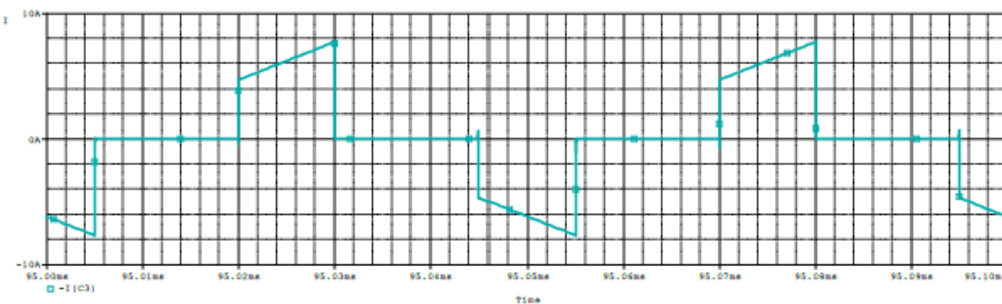

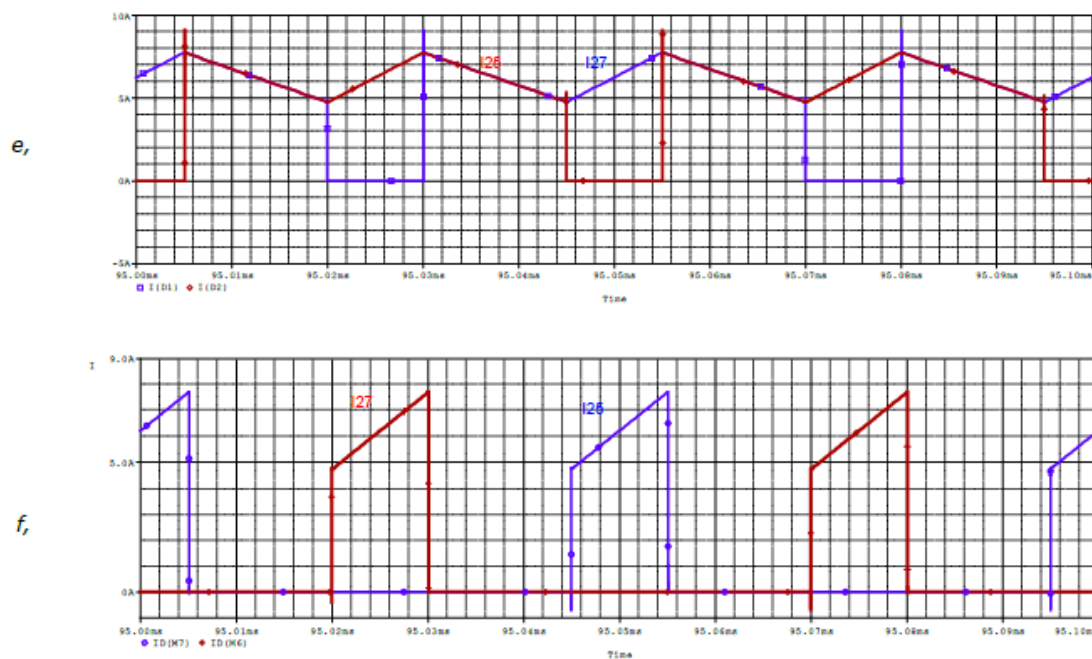

Figure 5 The typical curves:
a, the gate signals
b, the output, the input and the FC+ voltage
c, the voltage of the Flying Capacitor and the inductor current
d, the Flying Capacitor current
e, the currents of the diodes
f, the current of the transistors

Figure 5: Typical curves

2.3 The operation of the flying capacitor booster

The flying capacitor booster topology compared to the booster topology has the following advantages:

- As the operation is three level, the voltage stress on the semiconductor will be decreased. This resulting lower EMI, lower current and voltage ripple.



The flying capacitor booster topology compared to the symmetrical booster topology has the following advantages:

- It has two level input and output connection, while the third voltage level is synthesized by the flying capacitor. This way the large three level capacitors can be eliminated on the input and the output.
- Only one input choke is needed.

In both cases the input frequency is double of the switching frequency. This results a lower input ripple current or the inductance can be decreased. Because of the double frequency slower semiconductors can be used, what is decreasing the cost while the switching losses will be also lower. This means for optimal behaviour SiC MOSFETs are not needed, Si IGBTs can be used.

For more detailed comparison of the topologies and component selection please see Vincotech's benchmark "Boost your 1500 V string inverter" [1].

3 The flying capacitor

3.1 Sizing of the flying capacitor

The voltage supplied by the flying capacitor has a key role in this topology. To keep the voltage ripple on the capacitor low a suitable capacitor size is needed. To determine the needed capacitance the switching frequency and the maximum allowed voltage ripple need to be considered. The size of the capacitance can be calculated as:

$$C_{FC} = \frac{I_{peak}}{\Delta U_{FC} \cdot 2f_{SW}}$$

where ΔU_{FC} is the maximum allowed voltage ripple, I_{peak} is the maximum current, f_{SW} is the switching frequency of the transistors.

The frequency of flying capacitor voltage and current is equal to the switching frequency of the transistors.



3.2 Selection of the flying capacitor

This chapter on exemplary flying capacitor selection was kindly provided by TDK Electronics. The following assumptions apply: $\Delta U_{FC} = 80 \text{ V}_{pp}$ as the upper limit for the ripple voltage at the flying capacitor, a switching frequency of $f_{sw} = 16 \text{ kHz}$ and a maximum peak current of $I_{peak} = 60 \text{ A}$. Therefore, the required capacitance of the flying capacitor is $C_{FC} = 24 \mu\text{F}$, which can be calculated using the corresponding equation (see 3.1 Sizing of the Flying Capacitor).

The ambient temperature shall be $60 \text{ }^\circ\text{C}$, if the heat from the power modules does not significantly affect the flying capacitor. The generated heat is dissipated mainly through the PCB with a smaller fraction being dissipated into still air by natural convection.

Various capacitor technologies can be considered for this application. However, in the following the focus will be on TDK film capacitor and CeraLink® ceramic capacitor technology.

For film capacitors TDK offers different voltage and capacitance ranges for primary customer requirements in DC link operation. The mechanical design varies from 2 to 4 pins, while different lead space options also improve some electrical characteristics, such as low self-inductance and high resonance frequency. High resonance frequency, energy density, ripple current, ambient temperatures up to $125 \text{ }^\circ\text{C}$ and humidity protection are, in addition to long life expectancy ($> 100 \text{ k hours}$) and capacitance value stability, excellent design options for high frequency switching applications.

For film capacitor selection, modelling data and application simulation, please check the CLARA (Capacitor Life And Rating Application) online tool on TDK website.

CeraLink is a family of very compact capacitors for stabilizing voltages in the DC link or for use in snubber applications. These products are based on a unique antiferroelectric ceramic technology whose material exhibits increasing capacitance with increasing voltage. CeraLink® is designed to provide engineers with compact components optimized for fast switching converters (e.g., SiC/GaN), converters with very tight space requirements and converters that must withstand high operating temperatures of up to $150 \text{ }^\circ\text{C}$.

It is important to note that the capacitance behaviour of CeraLink® is non-linear and optimized for operation under DC bias and elevated ambient temperature; see the Technical Guide or the Simulation Toolbox for further details. With a DC bias level of 600 VDC and a super-imposed ripple voltage of 80 V_{pp} , a CeraLink® FA10 700 V type can be considered, offering an effective capacitance of typically $4 \mu\text{F}$ in the temperature range of 25 to $60 \text{ }^\circ\text{C}$.



The following tables compare the geometrical and electrical characteristics of the two considered capacitor solutions. If there are no space constraints, the film solution has more advantages in terms of cost and number of components, since one or a few parts can meet the electrical requirements. In contrast, CeraLink® could be an option if the total height of the solution is crucial or through-hole technology is not possible. Furthermore, CeraLink® shows clear advantages when a higher current capability is required and/or if the switching frequency is increased.

At a switching frequency of $f_{SW} = 16 \text{ kHz}$, the required capacitance of the FC is $C_{FC} = 24 \mu\text{F}$:

		TDK film capacitor 800 V DC (B32714H8805J000)**	TDK CeraLink® FA10 700 V DC (B58035U7505M001)
Width (max.)	[mm]	18.0	7.8
Height (max.)	[mm]	33.0	9.6
Length (max.)	[mm]	31.5.	30.5.
Volume	[cm ³]	18.7	2.3
Footprint	[cm ²]	5.7	3.3
Capacitance	μF	8.0	4
Current capacity	[A _{RMS}]	10.9.	16.0*
Total number of required caps	[]	3	6
Total footprint of solution	[cm ²]	17.1	19.8
Total volume of solution	[cm ³]	56.1	13.8
Total weight of solution	[g]	73.5	69.0
Total current capacity	[A _{RMS}]	32.7	96*
Mounting technology		Through-hole	Surface-mount

*At 16 kHz and 65 °C ambient temperature, 150 °C device temperature, no forced cooling

**Configuration for expected life endurance time, >88k hours in continuous application at 65 °C ambient temperature



At a switching frequency of $f_{SW} = 32 \text{ kHz}$, the required capacitance of the FC is $C_{FC} = 12 \mu\text{F}$:

		TDK film capacitor 1100 V DC (B32774H1335K000)**	TDK CeraLink® FA10 700 V DC (B58035U7505M001)
Width (max.)	[mm]	19.0	7.8
Height (max.)	[mm]	30.0	9.6
Length (max.)	[mm]	31.5.	30.5.
Volume	[cm ³]	17.9	2.3
Footprint	[cm ²]	5.9	3.3
<hr/>			
Capacitance	μF	3.3	4
Current capacity	[A _{RMS}]	11.8	22*
<hr/>			
Total number of required caps	[]	4	3
Total footprint of solution	[cm ²]	23.6	9.9
Total volume of solution	[cm ³]	71.6	6.9
Total weight of solution	[g]	81.2	34.5
Total current capacity	[A _{RMS}]	47.2	66*
<hr/>			
Mounting technology		Through-hole	Surface-mount

*At 32 kHz and 65 °C ambient temperature, 150 °C device temperature, no forced cooling

**Configuration for an expected life endurance time, >200k hours in continuous application at 65 °C ambient temperature

3.3 The balancing of the capacitor voltage

For the appropriate operation the flying capacitor voltage must be half of the output voltage. To achieve this, it must be always regulated. This can be done by changing the operation modes. As it can be seen in Table 1 Mode 1 and Mode 4 has no effect for the flying capacitor, so for regulation Mode 2 and Mode 3 must be used. The regulation state diagram can be seen on *Figure 6*.

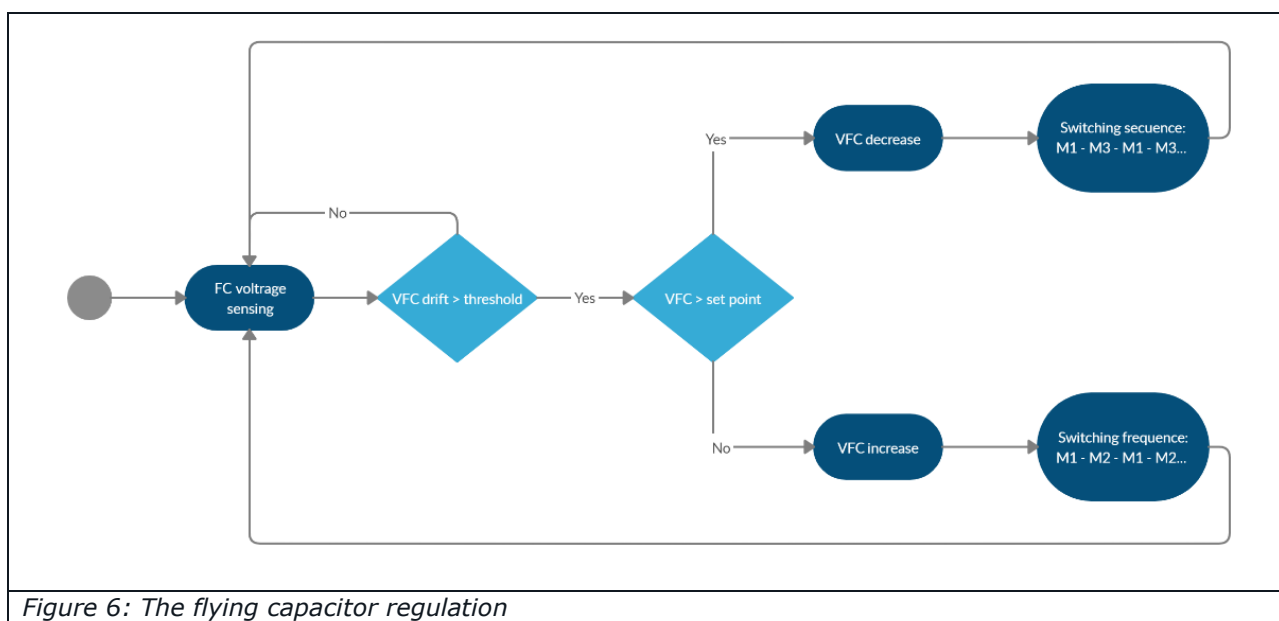

Figure 6: The flying capacitor regulation

As it was mentioned previously, the needed modes are depending on the duty cycle. In case of $D \leq 0.5$ the operation will be the following:

... → Mode 1 → Mode 2 → Mode 1 → Mode 3 → ...

If the Flying Capacitor voltage exceeds the set point the operation can be modified to decrease the voltage:

... → Mode 1 → Mode 3 → Mode 1 → Mode 3 → ...

If the Flying Capacitor voltage is less than the set point:

... → Mode 1 → Mode 2 → Mode 1 → Mode 2 → ...

In case of $D \geq 0.5$ the needed modification will be the same only Mode 4 will be used instead of Mode 1:

... → Mode 4 → Mode 3 → Mode 4 → Mode 3 → ... to decrease the voltage

... → Mode 4 → Mode 2 → Mode 4 → Mode 2 → ... to increase the voltage

3.4 The pre-charge of the capacitor [2]

This section will describe the details of the method proposed by Mitsubishi Electric Corporation to protect the flying capacitor booster when there aren't control signals (e.g.: during startup). This method is protected by DC/DC POWER CONVERSION APPARATUS© patent of the United States Patent Office. See section 3.4.2 on page 19 for further information on the applicable patent family and the option for sublicensing.

In case when all the control signals of the transistors are low, the flying capacitor voltage can't be regulated. In that operation extra effort needed to keep the flying capacitor voltage on the safe side to eliminate the overvoltage on the semiconductors which will cause a fatal error in the system. There are two operation modes when all the transistors are OFF. When the input is applied and the output is equal with the input (e.g.: startup). And when the input is zero and the output is not. This happens for example when one string is not connected to the circuit and other boosters are working. In all the two cases the voltage of the flying capacitor is zero, and the voltage sharing of the two transistors is not defined. To keep the voltage level of the semiconductors below the breakdown voltage additional balancing must be used.

During startup the current will flow through the two diodes and charge the output capacitance. In this case the output voltage will be equal to the input voltage while the flying capacitor voltage is zero. This is dangerous for the lower switch. To eliminate this problem another current path must be added, where the current will be able to charge the flying capacitor also. For this a diode can be used which cathode has to be connected to a capacitive voltage divider, where the lower point of the flying capacitor is clamped at the half of the DC-link voltage. This can be seen on *Figure 7*.

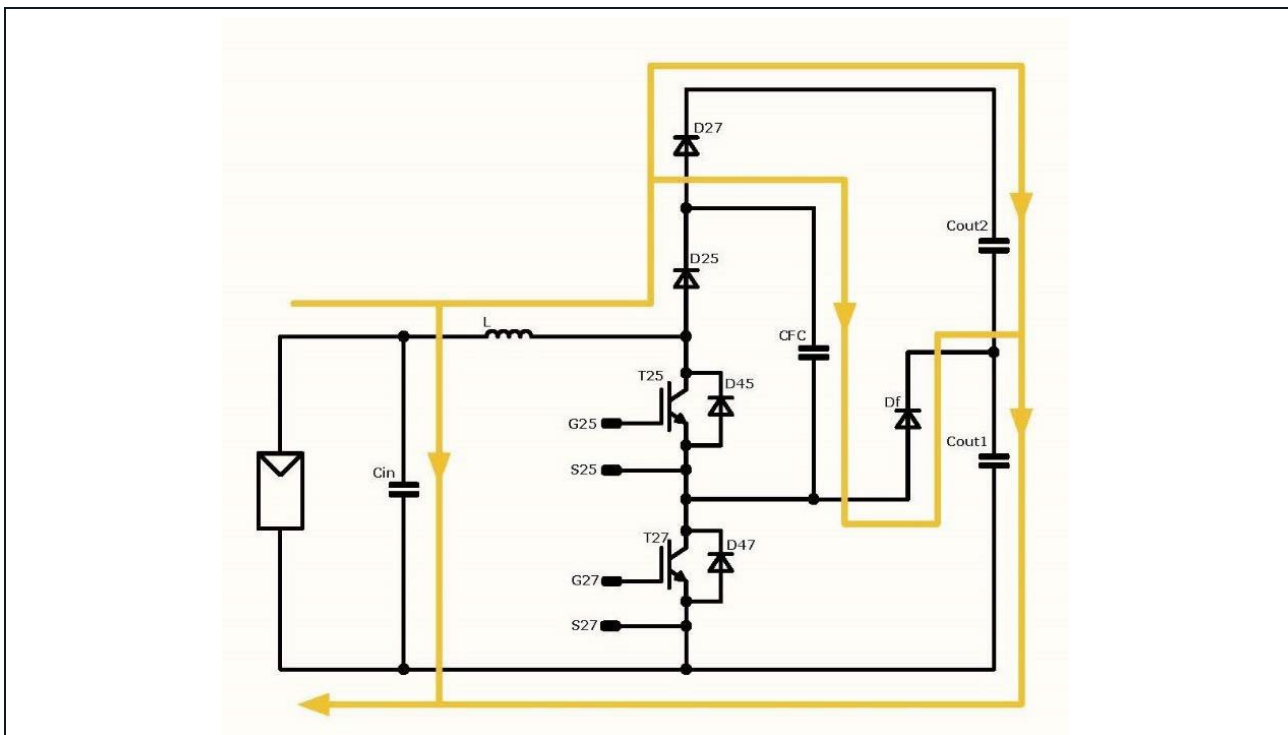

Figure 7: The additional current path during startup

As the voltage of the capacitor can be calculated from the following expression: $V=QC$, and the charge will be the same for C_{out1} and $C_{out2}+C_{FC}$, the flying capacitor voltage will be the following:

$$V_{FC} = V_{OUT} \frac{C_{out1}}{C_{out1} + C_{out2} + C_{FC}}$$

where V_{OUT} is equal with V_{In} (if the forward voltage of the diodes is not considered).

If the capacitance of C_{out1} and C_{out2} is equal and the capacitance of C_{FC} is significantly smaller than the capacitance of C_{out1} and C_{out2} , the voltage of the flying capacitor is half of the output.

$$C = C_{out1} = C_{out2}, \quad C_{FC} \ll C, \quad V_{FC} \approx \frac{V_{In}}{2}$$

When the string is not used and other boosters are working, the input voltage is zero, while the output voltage is not. In this case another diode has to be added to charge the flying capacitor.

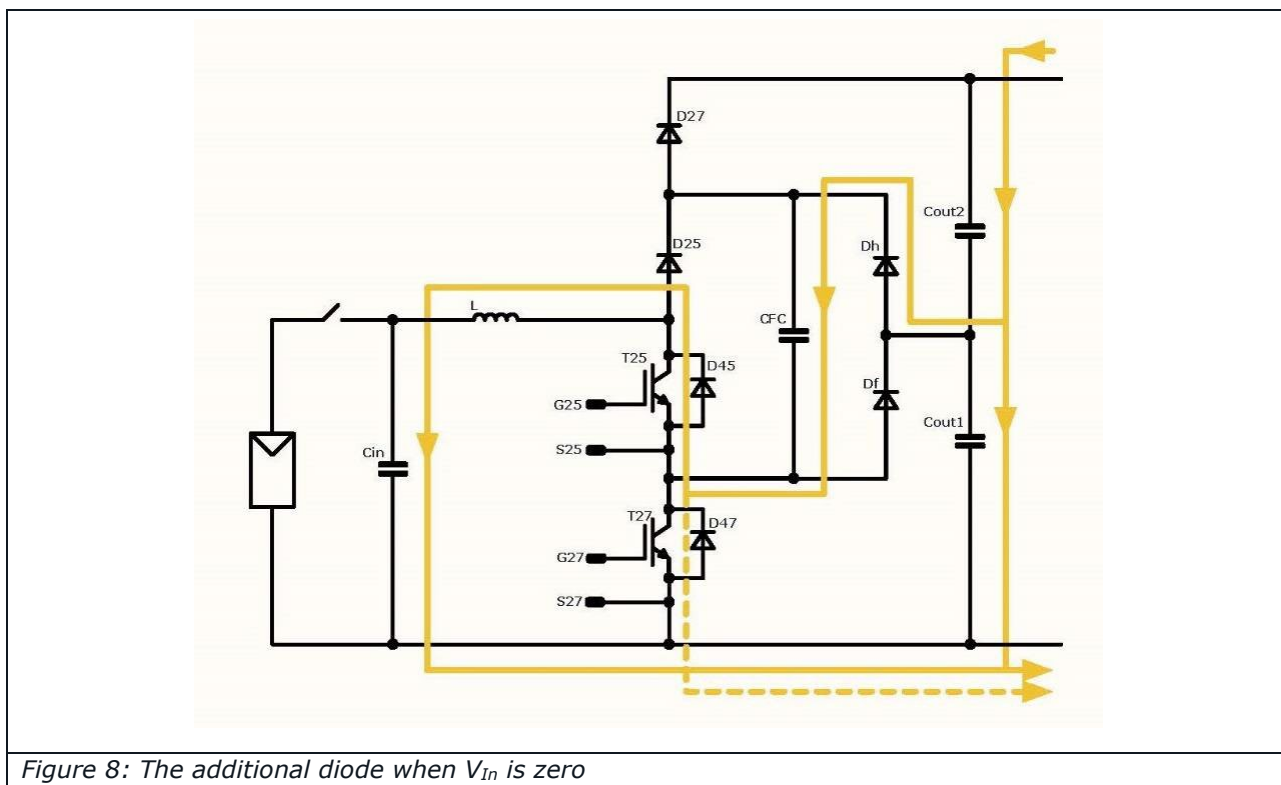

Figure 8: The additional diode when V_{In} is zero

As it can be seen on *Figure 8* the current path will be the following: $C_{out2} \rightarrow Dh \rightarrow C_{FC} \rightarrow D45 \rightarrow L \rightarrow C_{in}$

In this case the sum of the flying capacitor voltage and the input voltage can be calculated as the following:

$$V_{fcl} = V_{OUT} \frac{C_{out2}}{C_{out1} + C_{out2} + C_{FC} \times C_{in}}$$

As in the last expression, if C_{out1} and C_{out2} is equal and $C_{FC} \times C_{in}$ is negligible compared to C_{out1} and C_{out2} the voltage is half of the output voltage.

$$C = C_{out1} = C_{out2}, \quad C_{FC} \times C_{in} \ll C, \quad V_{fci} \approx \frac{V_{OUT}}{2}$$

This voltage will be divided on the two capacitors. If the capacitance of the C_{FC} is much smaller than the C_{in} capacitor then the voltage of the C_{in} capacitor is as low as it can be considered zero and the voltage of the flying capacitor is near to the half of the output voltage.

This method can be improved by closing T27 switch. In this case the voltage is not divided by C_{in} and C_{FC} capacitors and the current path will be the following: $C_{out2} \rightarrow Dh \rightarrow C_{FC} \rightarrow T27$

And the flying capacitor voltage:

$$V_{FC} = V_{OUT} \frac{C_{out2}}{C_{out1} + C_{out2} + C_{FC}}$$

3.4.1 Design considerations

During normal operation T27 will create an overvoltage spike at turn-off. If Df turns on to clamp this spike T27 switch will be loaded with the reverse recovery of Df. To avoid Df clamping this overvoltage spike an additional Zener diode (Dz) can be added in series with Df. The Zener voltage of the Zener diode should be higher than the spike of turn-off. This can be seen on *Figure 9*.

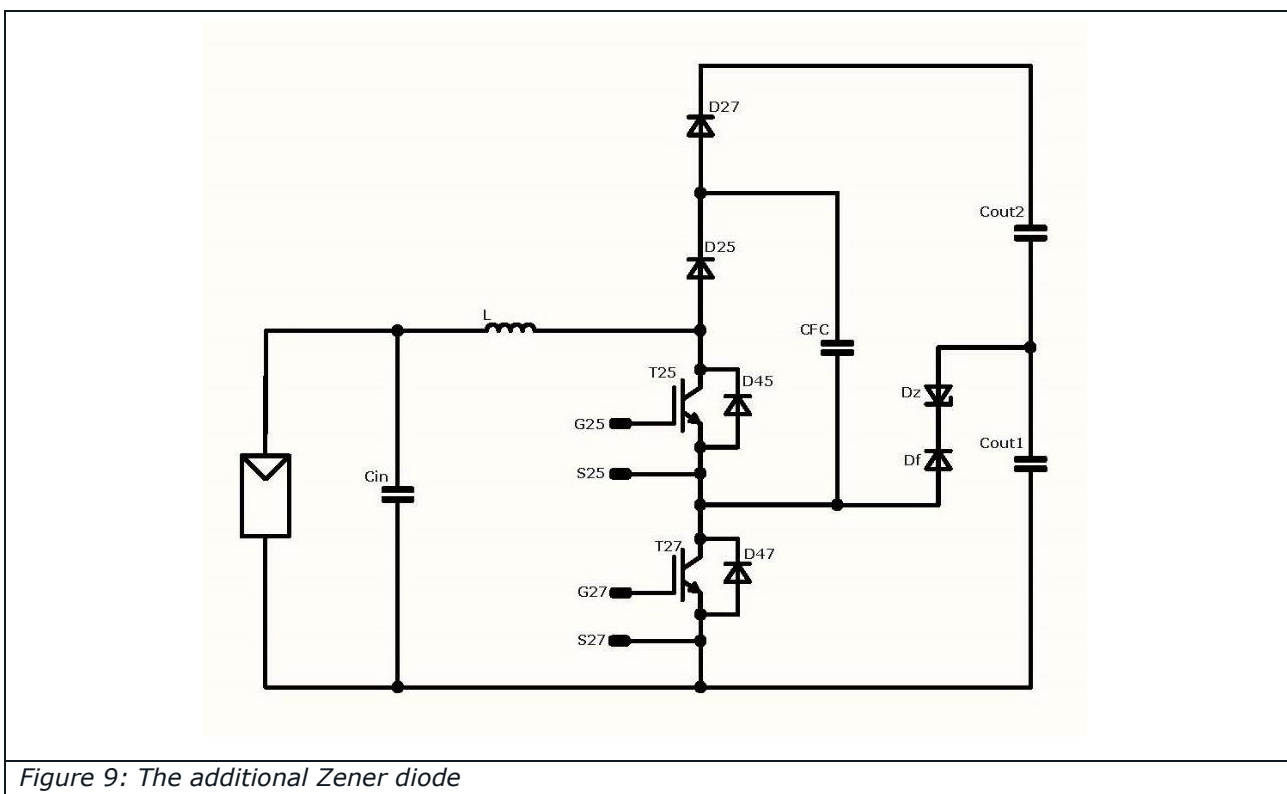

Figure 9: The additional Zener diode

If the voltage of flying capacitor is extremely higher than v_{out2} an additional current ripple will appear on the inductor. This ripple causes increased losses and noise. This ripple can be also moderated with this Zener diode.

If the voltage of C_{FC} is less than the voltage of C_{out2} an equalization current will flow between C_{FC} and C_{out2} resulting an unbalance between C_{out1} and C_{out2} . This imbalance can be decreased with a current limiting resistor (R_f) which can be seen on *Figure 10*.

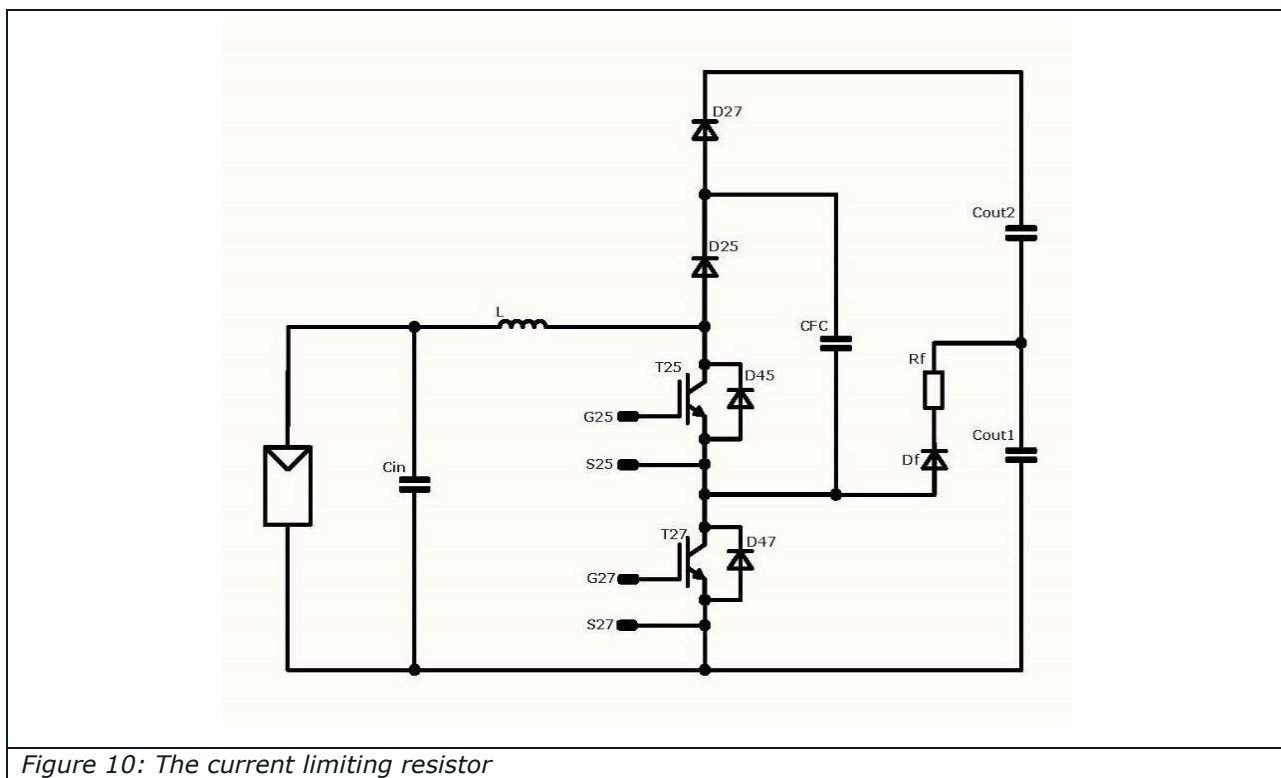

Figure 10: The current limiting resistor

3.4.2 Patent sublicensing

Mitsubishi Electric Cooperation holds the Japanese patent and all related patents in the patent family of JP 5379248 covering the flying capacitor pre-charge procedures described above. Vincotech is a group company of Mitsubishi Electric Corporation and eligible to sublicense the patent. The sublicensing agreement is bound to the usage of Vincotech power modules and allows the customer to use the patent without royalties.

To get further information about the sublicensing process and conditions please directly contact your local salesperson or use the contact form on www.vincotech.com.



4 Conclusion

The flying capacitor booster is a highly efficient low-cost solution for solar inverter applications. The main advantages are the frequency multiplication, the lower semiconductor voltage, the lower voltage and current ripple, the lower switching losses and the low EMI emission. The challenge is to regulate the voltage of the flying capacitor when all the transistors are in OFF state. This challenge can be solved easily by additional diodes based on Mitsubishi Electric Corporation's patent. With these diodes the flying capacitor booster is a cost-efficient alternative for the other booster solutions with higher efficiency.

5 References

- [1] M. Tauer, "Boost your 1500 V string inverter," Unterhaching.
- [2] T. Okuda and H. Ito, "DC/DC POWER CONVERSION APPARATUS". United States Patent US 2013/0021011 A1, 24 01 2013.



Vincotech GmbH

Biberger Strasse 93 | 82008 Unterhaching | Germany
T +49 89 878 067-0 | F +49 89 878 067-300

www.vincotech.com

Copyright © 2024