



Vincotech

ANALYSIS OF
TANDEM DIODE
SOLUTIONS
FOR POWER MODULES
IN MOTOR DRIVE
APPLICATIONS

EMPOWERING YOUR IDEAS



Analysis of tandem diode solutions for power modules in motor drive applications

Tiago Jappe, Product Marketing Manager, Vincotech

Matthias Tauer, Sr. Technical Marketing Manager, Vincotech

Zoltan Major, Sr. Electronic Engineer – Electric Components, Vincotech

1 Abstract

Three-phase variable speed drive (VSD) inverter systems commonly use 1200 V Si IGBTs with antiparallel freewheeling diodes (FWD) and are operated at switching frequencies in the range of 4 ~ 6 kHz. This article proposes an alternative Si-based FWD solution comprising two 650 V devices connected in series without snubbers or other additional elements. The proposed setup improves system efficiency and cost-effectiveness compared to conventional 1200 V Si FWD and SiC based designs. Experimental results demonstrate the reliability of the proposed tandem FWD setup and their ability to exceed performance requirements at an affordable cost.

2 Introduction

Standard motor drives operate at switching frequencies on the order of 4-6 kHz, while specific sub-applications such as servo-drives require higher switching frequencies of 16 kHz. While wide band gap (WBG) devices easily achieve these commutation speeds, they generally need to be slowed down to comply with motor specifications, which limit dV/dt levels to between 3-6 V/ns [1,2]. Slowing down WBG devices is, however, controversial, as it increases switching losses. Moreover, limiting switching frequencies to ~10 kHz, as is the case for many standard motor drive systems, makes it impossible to tap into the full benefits of WBG devices' high commutation rates. While combining Si IGBTs with SiC diodes would be an obvious solution, device makers have proposed several Si-based alternatives for three-phase variable speed drive (VSD) inverter systems [3], promising sufficient performance at a lower cost. The tandem diode solution is a remarkable approach that connects two Si 650V FWD devices in series. *Figure 1* depicts schematics of two versions of the sixpack topology. The conventional version (*Figure 1a*) uses 1200 V IGBT and diodes with the same voltage rating, current, and chipset technology, selected in concordance with general motor drive application requirements.

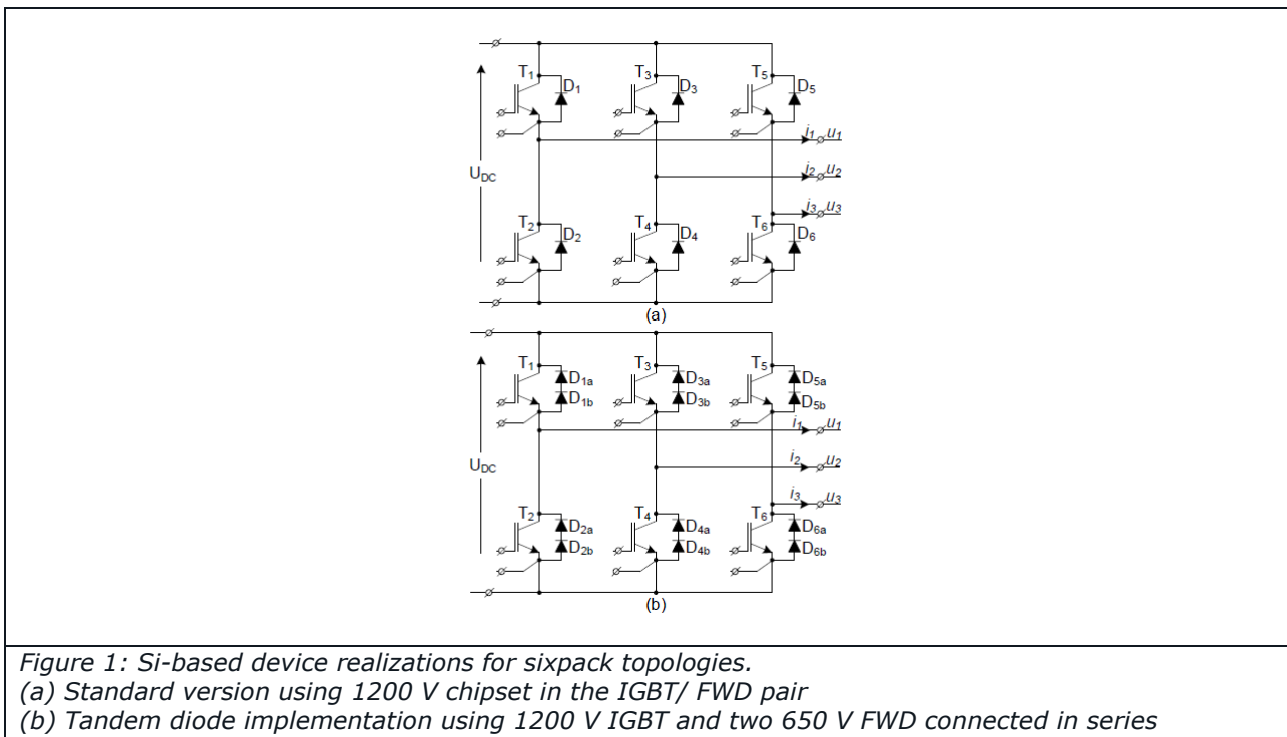

Figure 1: Si-based device realizations for sixpack topologies.
 (a) Standard version using 1200 V chipset in the IGBT/ FWD pair
 (b) Tandem diode implementation using 1200 V IGBT and two 650 V FWD connected in series

The tandem diode version (Figure 1b), combining a 1200 V IGBT and two Si 650 V freewheeling diodes connected in series. Tandem FWD setup has been proposed because it promises lower dynamic loss coefficients and superior reverse recovery behavior that could provide safe commutation and symmetrical voltage division in static and dynamic operation. This paper investigates the tandem diode concept, exploring its benefits and characteristics in sixpack topologies targeting motor drive applications. It experimentally evaluates the commutation safety of the tandem diode setup in static and dynamic operation and using high temperature reverse bias (HTRB) tests carried out on several FWD samples (tandem diode chipsets), demonstrating their high reliability under harsh operating conditions. It further compares the system level efficiency and cost of sixpack topologies with tandem diodes against a conventional solution.

3 General requirements for three-phase variable speed drive inverter

Figure 2 shows a block diagram representation of a typical three-phase variable speed drive inverter system. Starting with the load, the system is designed to perform a specific task in compliance with given rotor speed (ω_m) and torque (τ_e) specifications. The electromechanical actuator, which could be an induction machine (IM) or a permanent magnet synchronous machine (PMSM), directly converts electric power into mechanical power with a fairly high nominal efficiency (85% ~ 95%) compared to combustion engines. It is powered by a power

electronics converter (the second stage) that adjusts the amplitude and frequency of the machine stator voltage. It is a filter less implementation between machine and power converter in order to minimize the costs and provides a compact power conversion system. The inverter stage, in turn, is powered by an energy storage component such as a DC-link capacitor, which provides backup power during short grid outages and the means to dynamically accelerate and decelerate heavy loads. The grid voltage is rectified using another power electronic subsystem (the first stage) such as an active rectifier or a simple diode bridge rectifier (AC-DC).

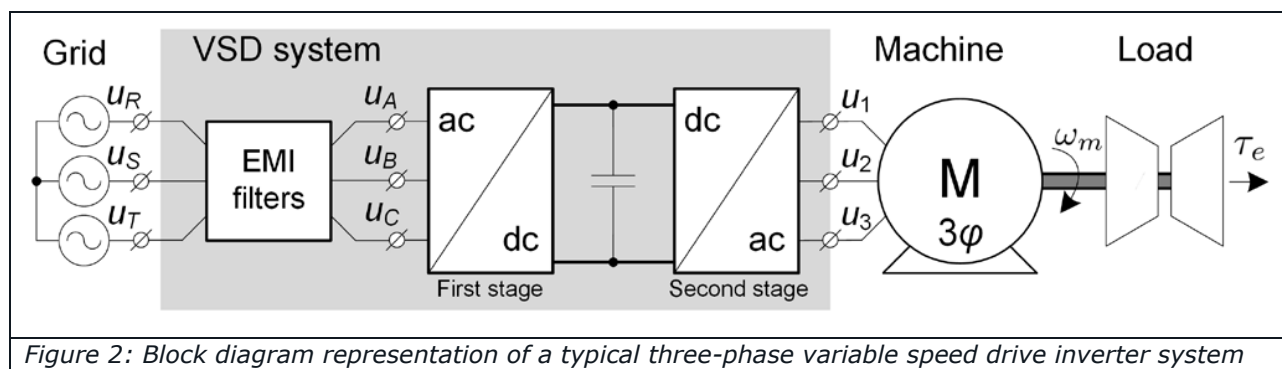

Figure 2: Block diagram representation of a typical three-phase variable speed drive inverter system

Since the proposed investigation focuses on filterless implementations between the converter and machine, the high switching frequency content is applied directly to the machine windings. These are switching transition times in the order of tens of nanoseconds. As a result, the switching device is subject to high voltage derivation over time transients. Over prolonged time periods, the high dV/dt values experienced by the switches and, consequently, by the machine can degrade winding insulations and bearings. Moreover, high dV/dt on motor terminals during the switching transients can cause insulation breakdown, non-uniform voltage distribution, common mode current, bearing current, and electromagnetic interference in electrical machines. It is, therefore, imperative to keep dV/dt below recommended values, which depend on the specific type of insulation.

The dV/dt across the IGBT, generally, can be adjusted by varying the gate resistance. Pushing the gate resistance to high values, however, introduces additional switching losses. The gate resistor should be carefully selected in order to limit dV/dt levels below 3-6 V/ns at minimal dynamic losses.

The tandem FWD implementation uses devices with proper technology that guarantees low reverse recovery losses to minimize switching losses at inverter stage of VSD systems.

4 Analysis of diode chipset technologies

The following section examines three alternative chipset diode technologies: a single 1200-V diode, a pair of connected tandem diodes, and a 1200 V SiC Schottky FWD implementation.

Figure 3 compares the forward voltage drop for each implementation. Taking a current of 60 A as a reference, the forward voltage drop is clearly smallest for the 1200 V diode, suggesting higher static losses in the sixpack with tandem diodes than in the conventional sixpack.

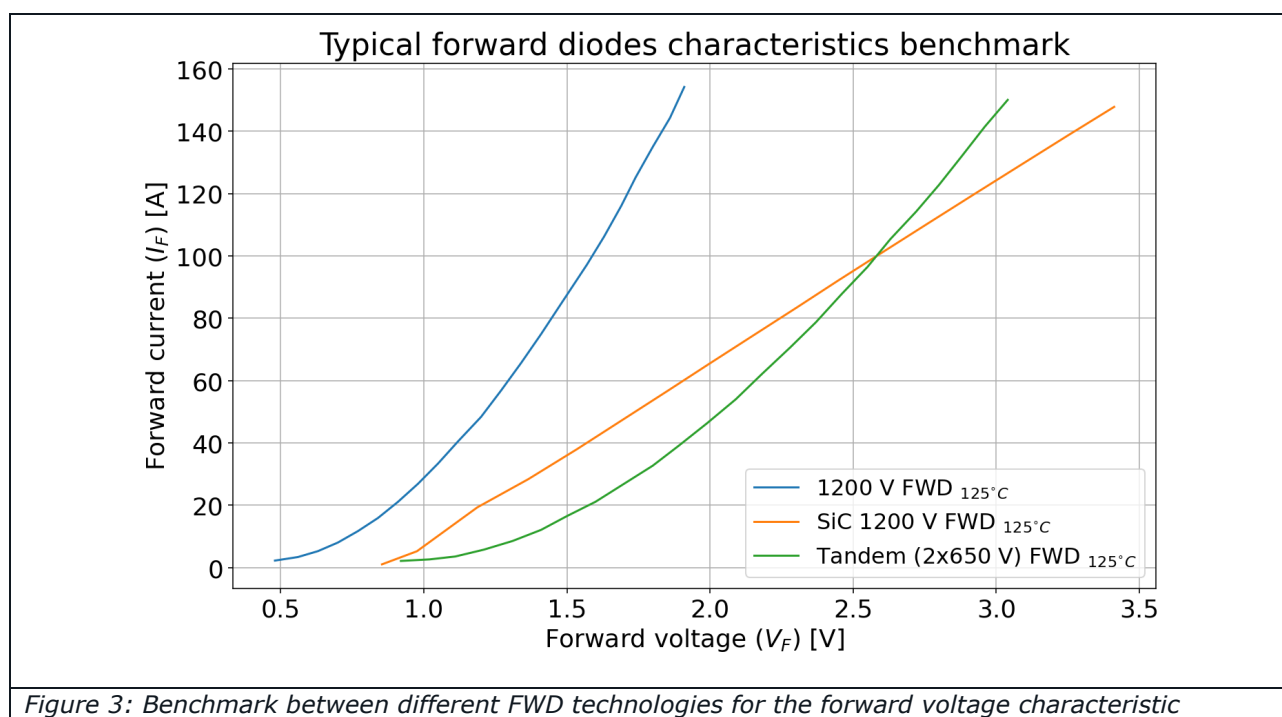

Figure 3: Benchmark between different FWD technologies for the forward voltage characteristic

The situation is opposite considering both – conduction and switching losses together, as demonstrated in Figure 4. At a switching frequency of 4 kHz, both the conventional sixpack and the tandem diode version exhibit similar semiconductor power losses, with efficiency ratings beyond 98.5 percent. At higher switching frequencies, FWD dynamic losses increase more sharply in the 1200 V diode setup than in the tandem diode setup. The tandem diode setup also reduces dynamic losses in the IGBT due to lower reverse recovery current from the FWD devices in the same leg.

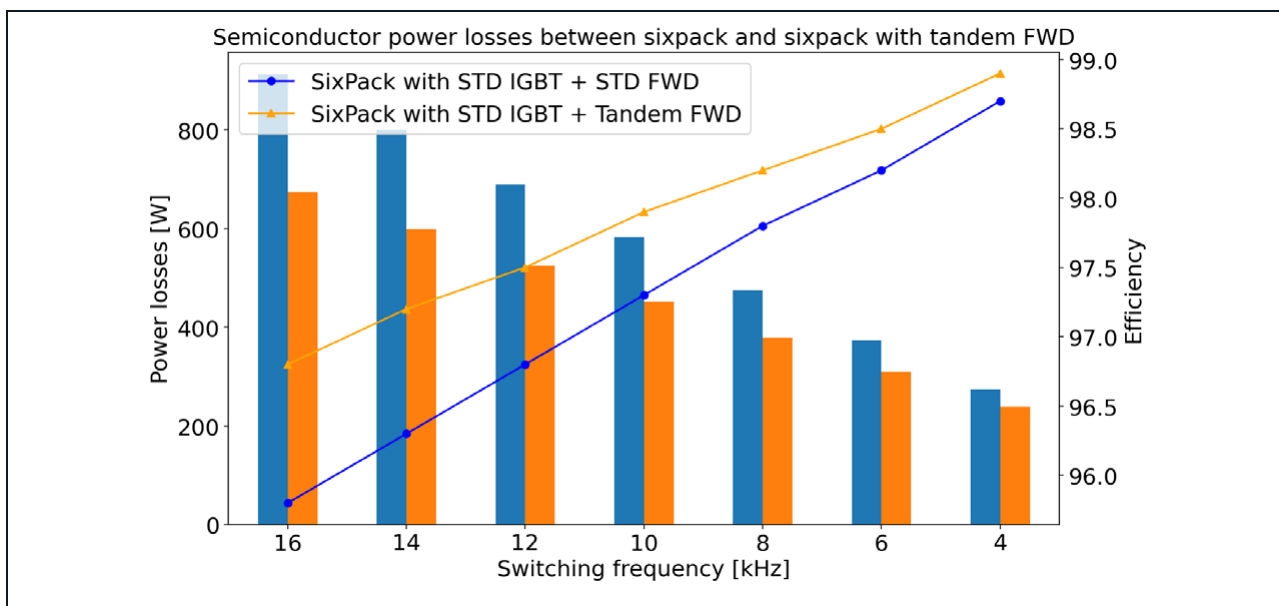

Figure 4: Power losses and efficiency results comparing the standard sixpack topology against the tandem diode implementation

Additional benchmark analysis has been proposed using high speed HS-IGBT technology and fast FWD against the standard IGBT with tandem FWD setup. The results are demonstrated in Figure 5. In this case, similar semiconductor power losses can be found for both chipset proposals in the range of mentioned switching frequencies (4 ~ 16 kHz).

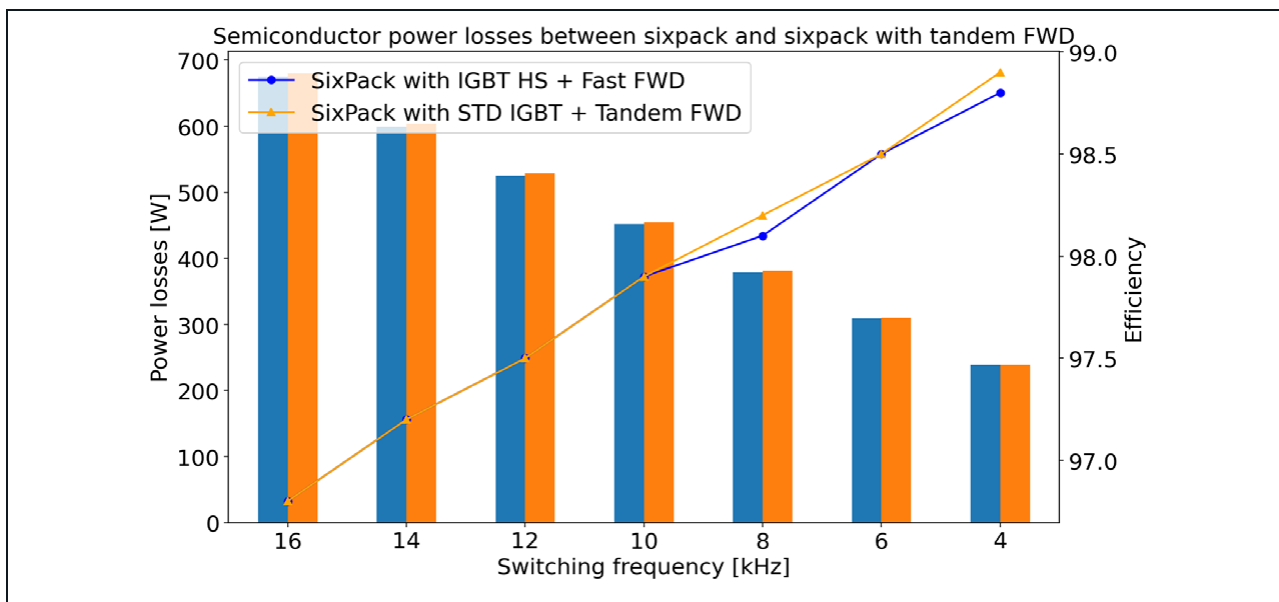

Figure 5: Power losses and efficiency results comparing the sixpack topology with (high speed) HS IGBT technology against the standard IGBT with tandem diode implementation



The semiconductor power loss benchmark was carried out using the following specifications:

- Switching frequency: 4 kHz - 16 kHz
- Gate resistor selected for $dV/dt = 5 \text{ V/ns}$:
- DC-link voltage $U_{DC} = 760 \text{ V}$
- RMS load voltage (line-to-line)
 $U_{Oll,rms} = 400 \text{ V}$
- RMS load current $I_{Orms} = 40 \text{ A}$
- Load power factor $PF = 0.86$
- Fundamental frequency synthesized at load $f_O = 50 \text{ Hz}$
Induction machine 25 HP, operating at full power – $P_m = 22 \text{ kW}$
Sixpack using standard 1200 V IGBT with standard 1200 V FWD:
"Vincotech: 80-M3126PA150M7-K829F70"
- Sixpack using standard 1200 V IGBT with tandem FWD
"Vincotech: 80-M3126TA150M7-K829F71"
- Sixpack using HS 1200 V IGBT Fast FWD
"Vincotech: 80-M3126PA150SH-K430F41"

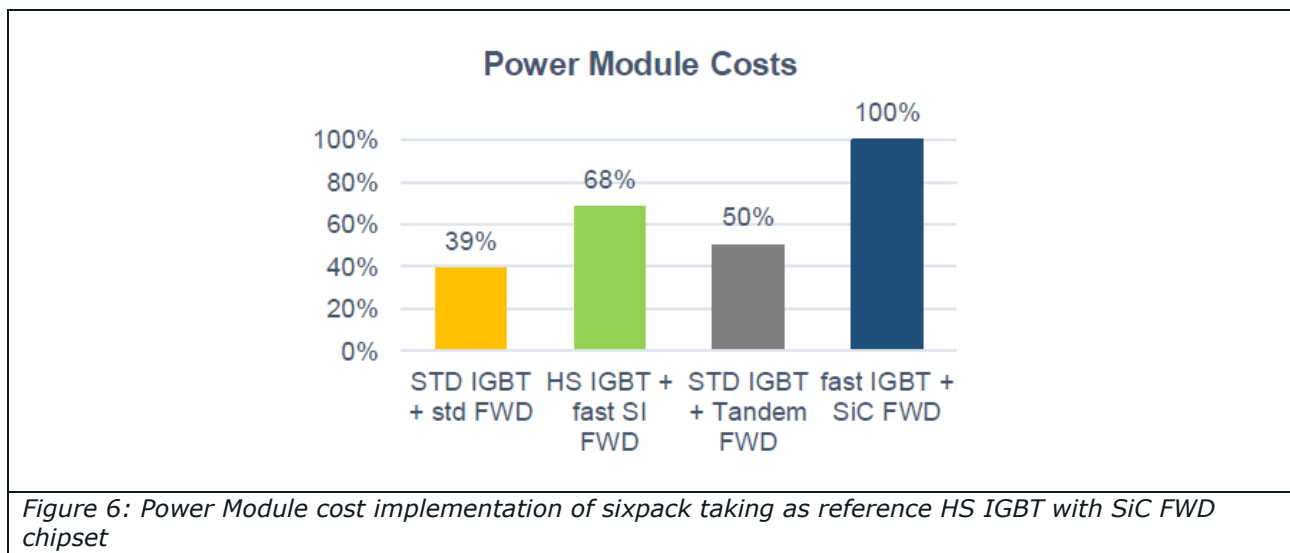

Figure 6 shows the power module cost for different chipset technologies. The reference is the most expensive version based on HS IGBT with SiC FWD. Since, similar semiconductor losses are found in the setup with HS IGBT with fast FWD comparing with standard IGBT with tandem FWD, the recommendation is to use tandem FWD concept, due to an equilibrated trade-off concerning cost and performance against other chipset alternatives.

Consequently, given the same system-level current and operating conditions, the sixpack topology with tandem diodes outperforms the conventional sixpack, and its advantage increases with the switching frequency. This is why implementations with tandem diodes are recommended for sixpack topologies operating at high switching frequencies for motor drive applications.

5 Reliability tests for the proposed tandem diode concept

A common concern when connecting two devices in series is how they divide the voltage during static and dynamic operation. While small voltage deviations between the diodes are to be expected in a tandem diode setup, larger deviations throughout the application lifetime could destabilize the system, ultimately leading to premature failure.

A series of experiments carried out in harsh operation conditions assessed the robustness of the proposed tandem diode chipset. Several FWD technologies were evaluated to find a solution that best meets the following criteria:

- Low cost
- Low reverse recovery coefficients
- Safe commutation and voltage division in static and dynamic operation
- Balanced voltage division without requiring additional external circuits (snubbers)

Figure 7 presents the setup used to perform static voltage sharing measurements.

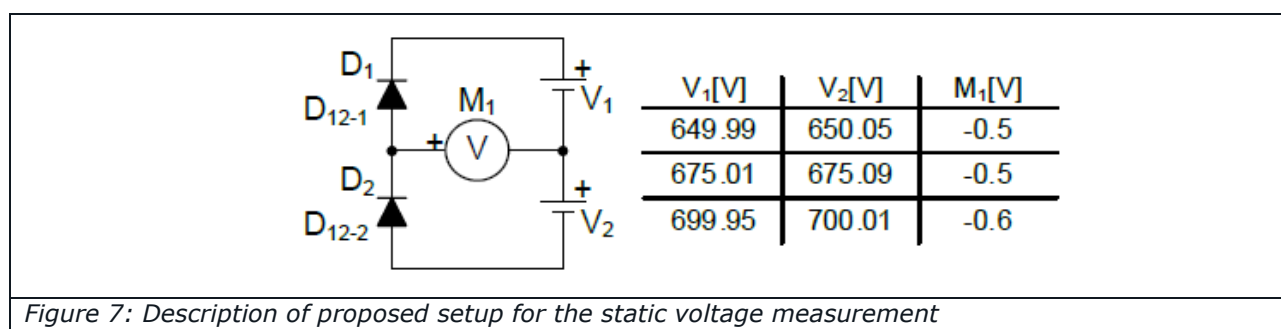
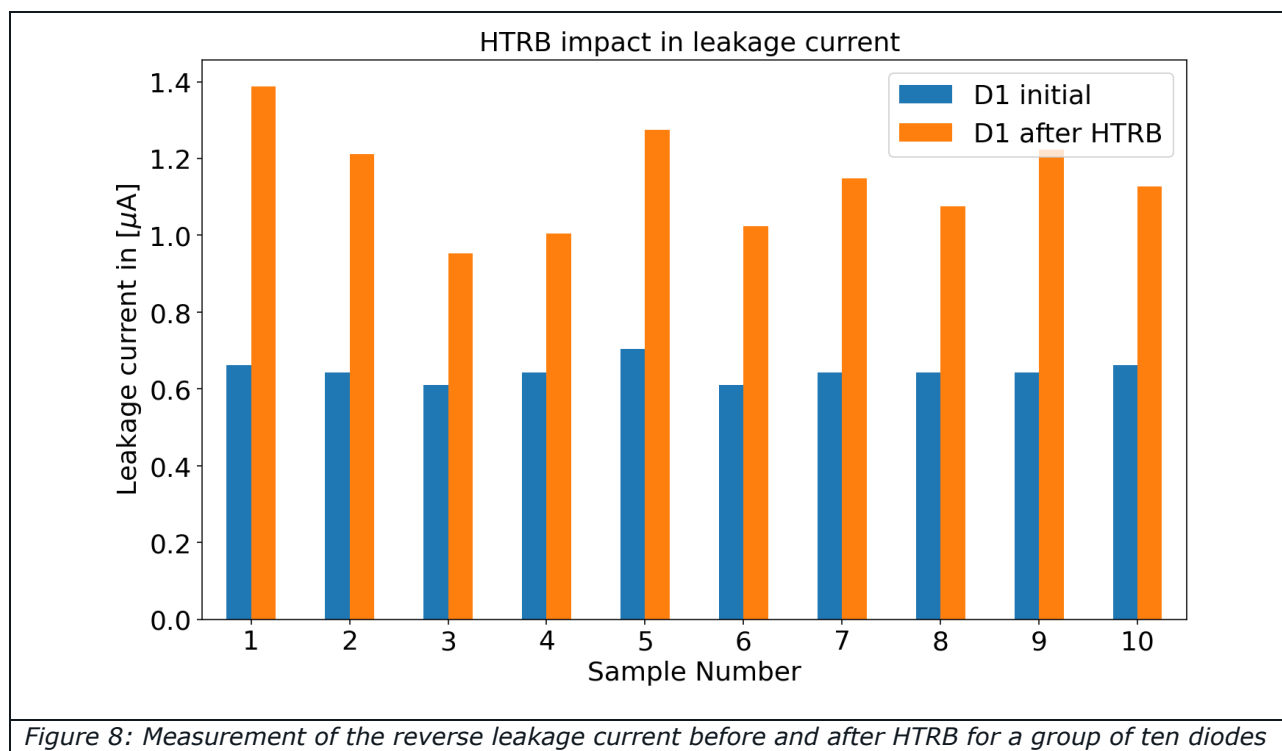

Figure 7: Description of proposed setup for the static voltage measurement

The tests were initiated with the voltmeter M_1 set close to zero. The voltage on D_1 was, therefore, given by voltage source V_1 , while the voltage across D_2 was given by V_2 . Measurements at M_1 indicate voltage deviations between both diodes. Measured values were reported for various diode technologies as shown in Figure 6. The selected tandem-diode technology showed a marginal imbalance between the diodes on a single semiconductor wafer, as indicated by the voltage on M_1 .

5.1 Reverse leakage current measurement

Next, 40 individual diodes were divided into three groups based on whether they had a high, low, or average leakage current. Next, the diodes were assembled in the tandem-diode configuration and the leakage current for each device was measured before and after aging. The devices paired diodes with high and low leakage currents, and diodes with average leakage currents. Aging was performed for 1000 hours using the high temperature reverse bias (HTRB) test system (acc. EN60749-23) at a virtual junction temperature, T_{vj} , of 175 °C and a reverse voltage, V_r , of 1280 V, corresponding to over 15 years in a real-world application. To evaluate the results, the diodes were again grouped based on their leakage current, creating a high leakage group (*Figure 8*), a low leakage group (*Figure 9*), and two average leakage groups (*Figure 10* and *11*).



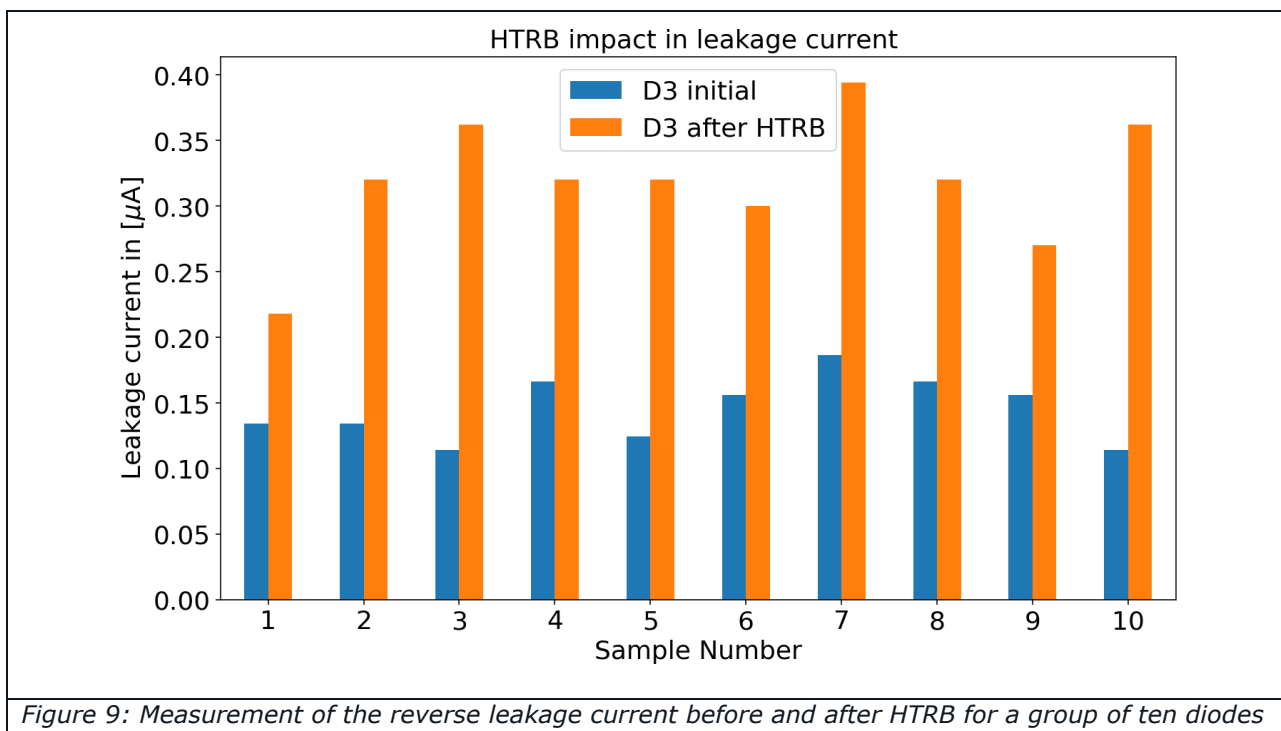

Figure 9: Measurement of the reverse leakage current before and after HTRB for a group of ten diodes

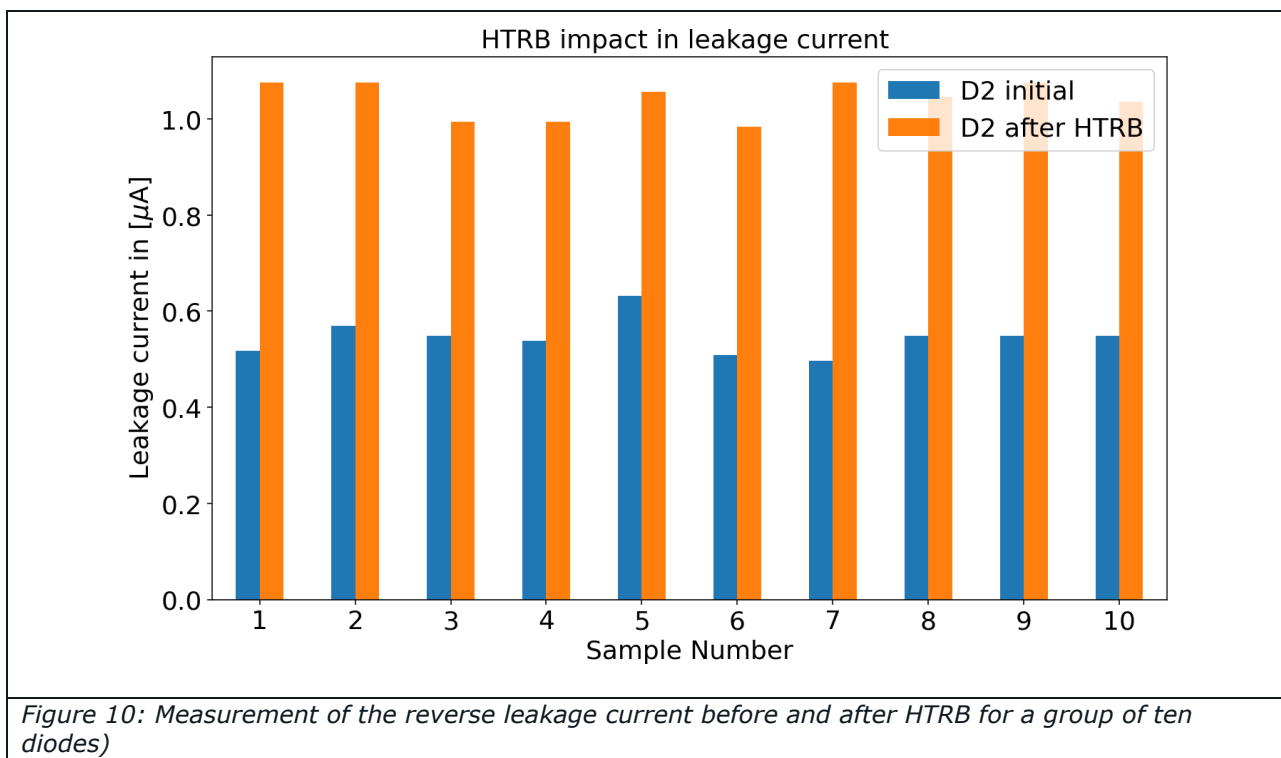
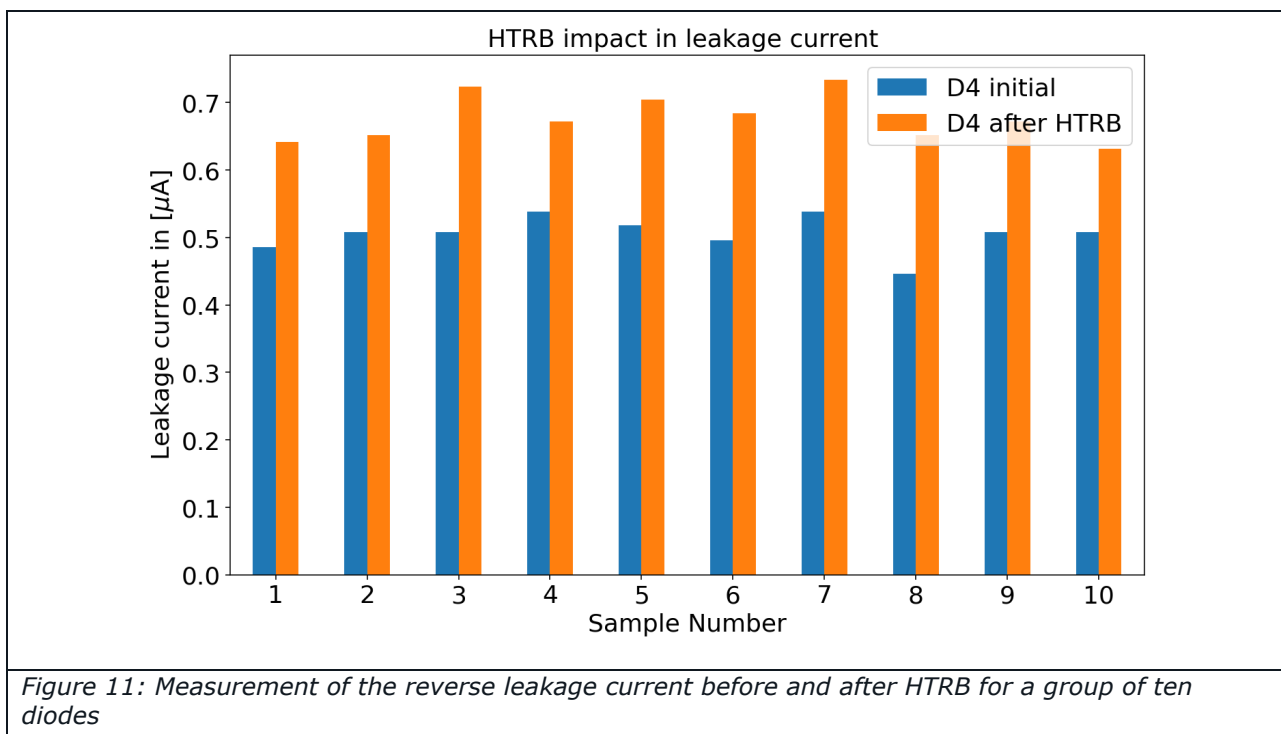

Figure 10: Measurement of the reverse leakage current before and after HTRB for a group of ten diodes)



In each case, aging the diodes in the tandem diode configuration increased the reverse leakage current of each individual diode. To assess the effect of aging on the tandem setup, the reverse leakage current of the tandem diode configuration was measured at a reverse voltage, V_r , of 1300 V, with the tandem diode pairs again selected to form two groups. The first combined diodes with high and low reverse leakage currents to simulate a “worst-case” scenario in which unequal voltage division across the diodes would seem likely. The second group combined diodes with an average reverse leakage current, simulating or more balanced configuration.

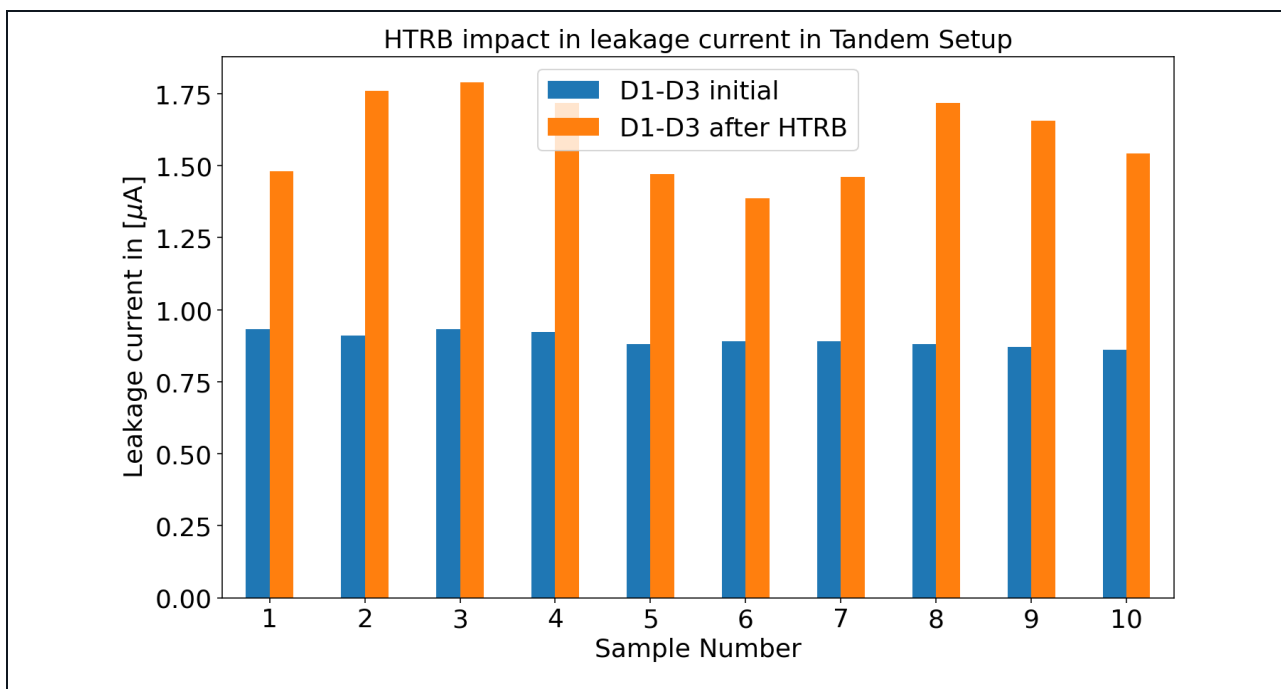

Figure 12: Measurement of the reverse leakage current of the tandem diode configuration before and after HTRB using diodes with high and low reverse leakage current

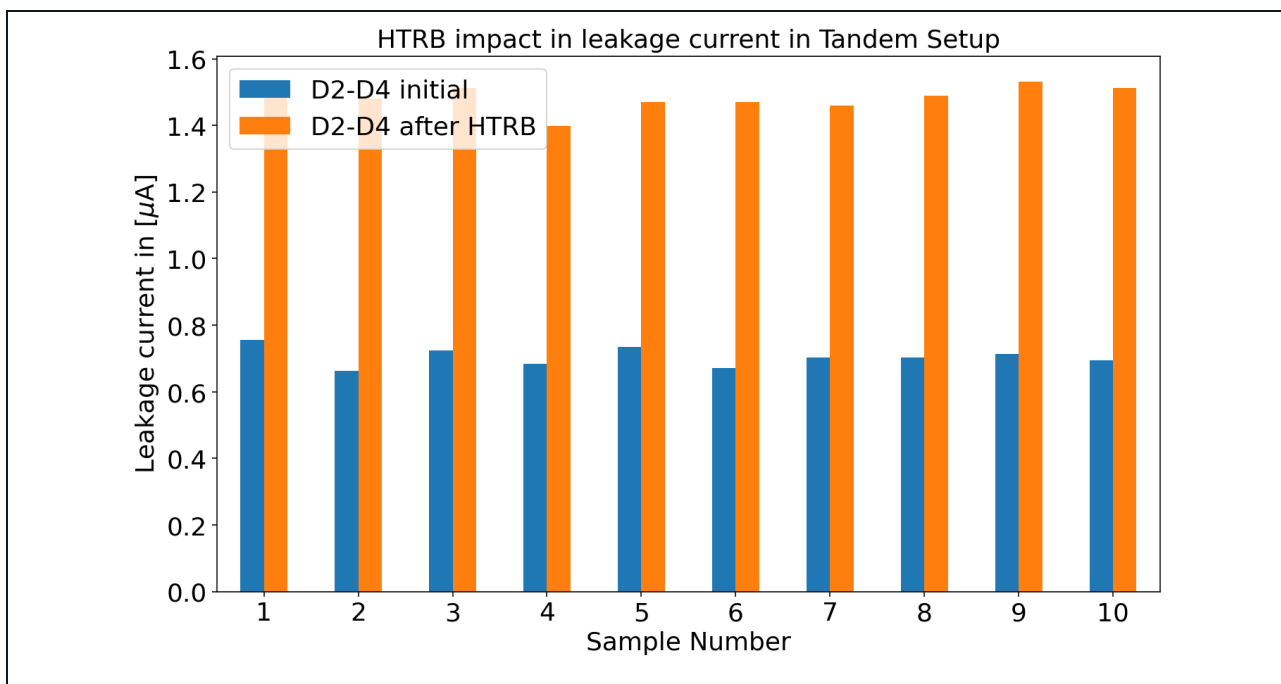

Figure 13: Measurement of the reverse leakage current of the tandem diode configuration before and after HTRB using diodes with average reverse leakage current

As can be seen in Figures 12 and 13, aging the diodes in the tandem configuration using the HTRB test increased the reverse leakage current in each case. The combination of diodes with average reverse leakage currents showed a slightly smaller leakage current distribution than the combination of high and low reverse leakage current diodes.

5.2 Breakdown voltage measurement

Measuring the breakdown voltage for the same tandem diode configurations as in the previous step revealed the robustness of the proposed setup.

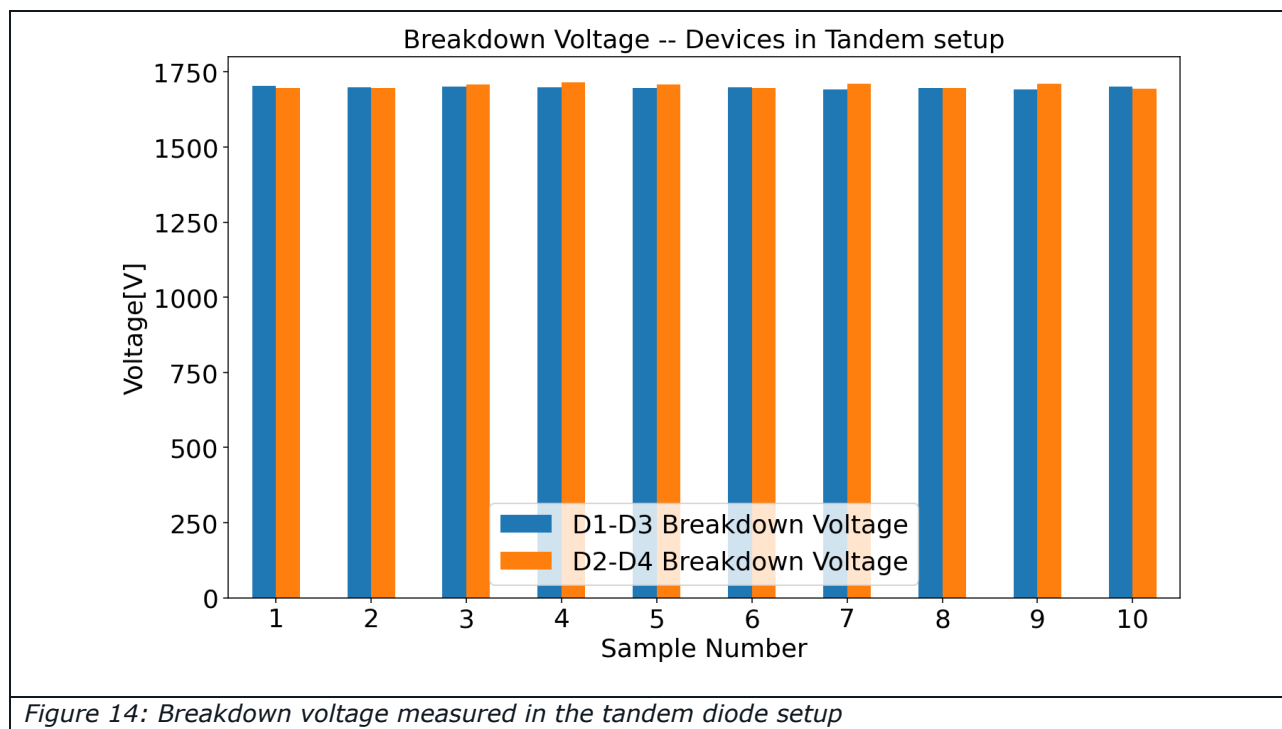

Figure 14: Breakdown voltage measured in the tandem diode setup

Remarkably, the minimum breakdown voltage for tandem diode pair with the highest reverse leakage current after HTRB (Figure 14, sample 3) was roughly the same as that for the tandem diode pair with the lowest reverse leakage current after HTRB (Figure 14, sample 6). In both cases, it was well above the nominal breakdown voltage of two 650 V diodes connected in series, which would be 1300 V. Finally, the minimal breakdown voltage of each diode in the tandem diode setup was measured individually after aging (Figure 15).

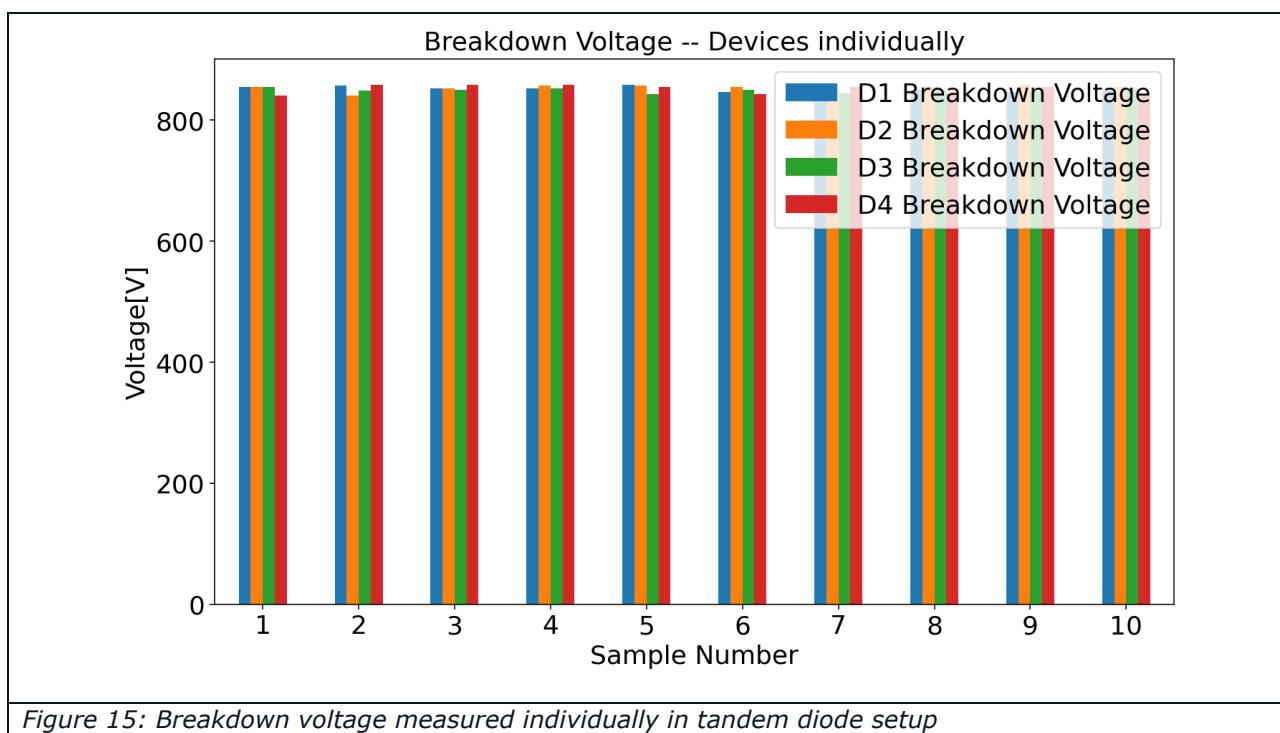

Figure 15: Breakdown voltage measured individually in tandem diode setup

The minimum breakdown voltage was around 840 V, while the nominal breakdown voltage was reported as 650 V. Again, diodes that initially presented a high, low, and average reverse leakage current presented no systematic differences in their minimum breakdown voltages.

These results demonstrate that for VSD inverter systems drawing a typical DC-link voltage of 800 V, the selected tandem diode technology offers stable reliability and sufficiently high blocking voltage throughout its entire lifetime.

6 Conclusion

This article investigated various Si-based alternatives to WBG-based solutions for three-phase variable speed drive (VSD) inverter systems. Experiments revealed that a tandem diode setup comprised of two snubber-less 650 V devices connected in series outperformed solutions using a single 1200 V FWD in terms of overall semiconductor efficiency losses at high switching frequencies at a far lower price point than WBG-based solutions.

To ensure system longevity of the tandem diode setup, the reverse leakage current of individual diodes and diode pairs were measured before and after aging them by the equivalent of 15 years in the field using the HTRB tests. Subsequently, the minimum breakdown voltage of the tandem diode setup as well as that of each individual diode were



assessed.

The reverse leakage current distribution of the tandem diode setup using diode pairs with high and low individual reverse leakage currents was higher than that of diode pairs with average individual reverse leakage currents. Nonetheless, diodes with high, low, or average reverse leaking currents revealed no systematic differences in their minimum breakdown voltage. This paper's findings show that the tandem diode configuration offers a reliable and efficient low-cost alternative to WBG-based solutions for three-phase variable speed drive (VSD) inverter systems.

7 References

[1] "Rotating Electrical Machines Part 18-41," International Electrotechnical Commission, Geneva, CH, Standard, 2014.

[2] "Motors and Generators - NEMA MG 1," The Association of Electrical Equipment and Medical Imaging Manufacturers, Standard, 2016.

[3] RM. Haider, M. Guacci, D. Bortis, J. W. Kolar and Y. Ono, "Analysis and Evaluation of Active/Hybrid/Passive dv/dt -Filter Concepts for Next Generation SiC-Based Variable Speed Drive Inverter Systems," 2020 IEEE Energy Conversion Congress and Exposition (ECCE), Detroit, MI, USA, 2020, pp. 4923-4930,



Vincotech GmbH

Biberger Strasse 93 | 82008 Unterhaching | Germany
T +49 89 878 067-0 | F +49 89 878 067-300

www.vincotech.com

Copyright © 2023