



CRANK IT! REVOLUTION



PLACE SERIAL NUMBER LABEL HERE

FACTORY CONTACT INFORMATION



Our Vision:

We aspire to be the best in the world at developing and manufacturing coin operated games for our customers.

BAY TEK GAMES INC.
Pulaski Industrial Park
1077 East Glenbrook Drive
Pulaski, WI 54162 U.S.A.
www.baytekgames.com

JOIN SERVICE FIRST NETWORK!

This free service is intended to keep you up to date on the latest game information, early notification of parts specials, pertinent technical bulletins, updates on retro fit parts, software upgrades, & much more. Log on to:
www.baytekgames.com/parts
& then click on the Service First icon.

8 AM - 5 PM C.S.T. MON - FRI



SALES

P: 920.822.3951
F: 920.822.8936
sales@baytekgames.com

PARTS

P: 920.822.3951 x 1101
F: 920.822.1496
parts@baytekgames.com

SERVICE:

P: 920.822.3951 X 1102
F: 920.822.1496
service@baytekgames.com

All games proudly manufactured at our factory in Pulaski, Wisconsin U.S.A.

TABLE OF CONTENTS

FACTORY CONTACT INFORMATION	2
WELCOME TO: CRANK IT REVOLUTION!	4
HOW TO PLAY	5
SPECIFICATIONS	6
SAFETY PRECAUTIONS	6
DIP SWITCH SETTINGS	7
MAIN MENU FUNCTIONS	8
CREDITS PER PLAY	9
TICKET PATTERNS	9-11
GAME VOLUME	12
ATTRACT MODE VOLUME	12
PRINTER SETTINGS	13
WHEEL POSITION DIAGNOSTICS	14
TICKET VALUE DIAGNOSTICS	15
WIRING AND CABLE DIAGRAMS	16-22
TROUBLESHOOTING GUIDE	23-26
POWER SUPPLY DIAGNOSTICS	27
BILL ACCEPTOR DIAGNOSTICS	28
HOW TO: CHANGE ARROW POSITION	29
HOW TO: ADJUST WHEEL SENSOR	30
HOW TO: CLEAN GAME	30
HOW TO: SET BRAKE TENSION	31
HOW TO: CHANGE TICKET PATTERN	32
HOW TO: REMOVE WHEEL	33-34
HOW TO: INSTALL PRINTER	35-36
PIVOT ASSEMBLY DIAGRAM	37
PARTS LISTS	38-40
MAINBOARD PINOUT	41-44
MAINTENANCE LOG	45
TECHNICAL SUPPORT	46
WARRANTY	47

WELCOME TO: CRANK IT REVOLUTION!

Congratulations on your Crank It Revolution purchase!

Double the excitement of the original Crank It, Crank It Revolution offers two players at a time to spin and win a big bonus! With fun, colorful graphics, attractive LED lighting, dot-matrix display, and a goofy, infectious audio package, Crank It is sure to entertain the little, the big, and everyone in between!

Lift up and push down the handle to spin the wheel. Boogie to the funky beat as you wait for the wheel to stop, and win tickets according to where the arrow is pointing!

Please take a moment to read through this manual and be sure to contact our factory if you have any questions, or would like some more information.

Thank you for your purchase! Your business is important to us and we hope you enjoy this game as much as we do!

Your Friends at Bay Tek Games



GAME INSPECTION

Inspect the game for any damaged, loose, or missing parts. If damage is found, please contact your freight carrier first. Then, contact Bay Tek Games Service Department at 920.822.3951 or e-mail them at service@baytekgames.com for further assistance.

HOW TO PLAY

Crank it up...

Crank it down...

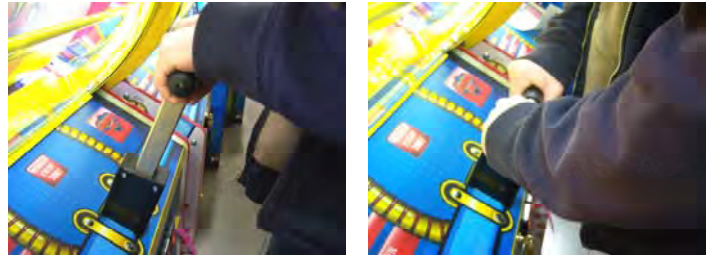

Watch the wheel spin 'round and 'round!

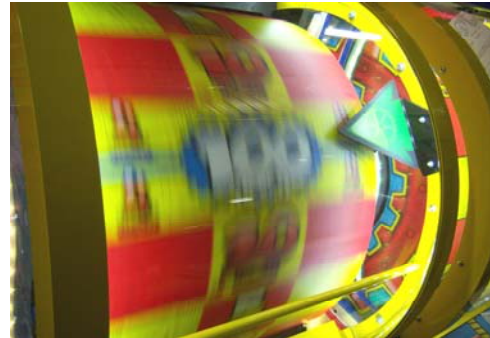

Land the arrow on a space...



Put a smile on your face!



Land on a blue space twice in a row...

And off with jackpot tickets you go!



SPECIFICATIONS

WEIGHT	
WEIGHT	800 lbs.
SHIP WEIGHT	900 lbs.

DIMENSIONS	
WIDTH	57.5
DEPTH	39"
HEIGHT	83"











OPERATING TEMPERATURE	
80 - 100 Degrees	Fahrenheit
26.7 - 37.8 Degrees	Celsius

POWER REQUIREMENTS			
INPUT VOLTAGE RANGE	100 to 120 VAC	or	220 to 240 VAC
INPUT FREQUENCY RANGE	50 HZ	to	60 HZ

MAX START UP CURRENT
2.5 AMPS @ 115 VAC
1.25 AMPS @ 230 VAC

OPERATING CURRENT
2.1 AMPS @ 115 VAC
1.2 AMPS @ 230 VAC

SAFETY PRECAUTIONS

 DANGER 
DO NOT perform repairs or maintenance on this game with the power ON. Unplug the unit from the wall outlet or shut off the power at the power strip located inside the game cabinet.
 WARNING 
Use of flammable substances can cause severe burns or serious injury. Always use NON-FLAMMABLE solvents for cleaning. DO NOT use gasoline, kerosene, or thinners.
 CAUTION 
Lifting heavy objects can cause back, neck, or other injuries. Be sure adequate lifting and moving devices are available when unloading, unpacking, and moving this game.
 ATTENTION 
Be sure the electrical power matches the game requirements. See the serial number decal located on the back of the game cabinet. Always plug game into a grounded circuit. If the supply cord is damaged, it must be replaced by a special cord or assembly available from the manufacturer or its service agent.
 IN CASE OF EMERGENCY: 
Unplug the power cord. The power cord must be accessible <u>at all times</u> in case of emergency.

DIP SWITCH SETTINGS

The dip switch bank is located on the main board, inside the front door of the game.

*factory default settings are highlighted in blue

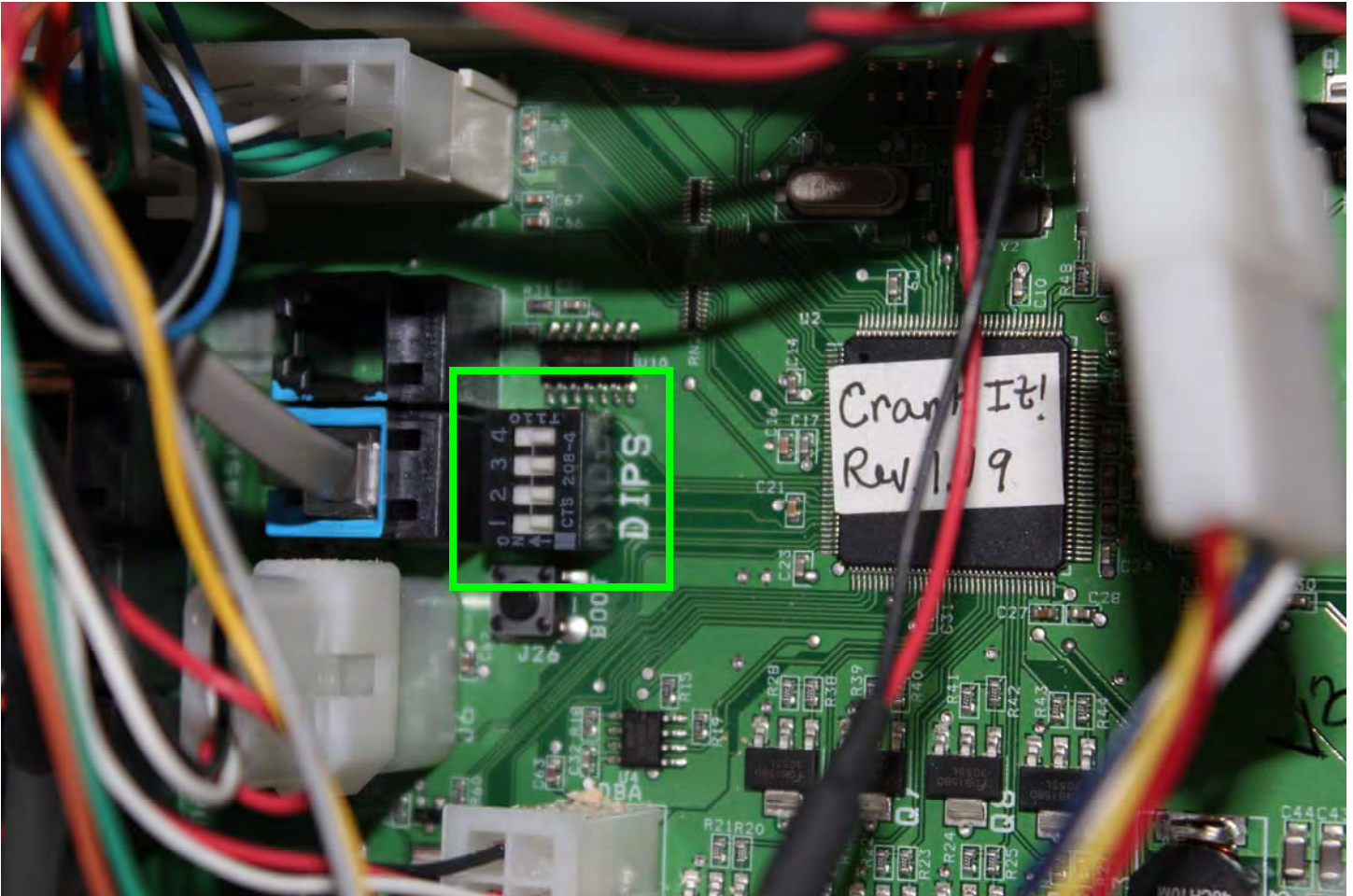

SWITCH	ON	OFF
1	Double-value tickets ON	Double-value tickets OFF
2*	Standard arrow position	Lower "kiddie" arrow position
3	Jersey Shore settings ON	Jersey Shore settings OFF
4	Brake Test ON	Brake Test OFF

* See page 25 to change arrow position

DETAILED OPERATIONS

MENUS

1. Press and hold the “MENU” buttons inside the front door of the player stations for **3 seconds**
2. Tap the “MENU” button to scroll through the menu options
3. To choose an option, press the “SELECT” button
4. Scroll through the menu settings with the “SELECT” button
5. To make your selection, press the “MENU” button to scroll through the remaining menus past 8 to exit



MENU	DESCRIPTION
1	CREDITS PER PLAY
2	TICKET PATTERNS
3	CHANGE JACKPOT VALUE
4	GAME VOLUME
5	ATTRACT MODE VOLUME
6	GOOD SPIN WHEEL SPEED
7	PRINTER SETTINGS
8	WHEEL POSITION DIAGNOSTICS
9	TICKET VALUE DIAGNOSTICS

MENU 1– CREDITS PER PLAY

Scroll through the n1 menu with the “menu select” button.
 Make your selection by pressing the “menu button” and scrolling
 through the remaining menus past n8 to exit the menu.

*Factory default settings are highlighted in BLUE.

1	2	3	4	5	6	7	8
---	---	---	---	---	---	---	---

MENU 2– TICKET PATTERNS

Scroll through the n2 menu with the “menu select” button.
 Make your selection by pressing the “menu button” and scrolling
 through the remaining menus past n8 to exit the menu.

*Factory default settings are highlighted in BLUE.

These settings should not be changed unless the decals on the game’s wheel are also changed.

We encourage you to try the thoroughly tested standard factory ticket pattern for at least a month before deciding to change it.

Please contact our Service Department to order replacement decals if you do decide to change the ticket pattern on your game.

QUICK REFERENCE CHART

Ticket pattern:	1	2	3	4	5	10	11	12	13
Credits / Price per play:	2 / \$.50	2 / \$.50	2 / \$.50	4 / \$1.00	4 / \$1.00	1 Euro	30 Pence	40 Pence	2 / \$.50
Bonus Value	250	250	1000	500	1000	1000	250	250	500
Jackpot Value	1000	2500	2500	5000	2500	5000	1000	1000	1000

MENU 2– TICKET PATTERNS, cont.

1

50¢/250 bonus
1000 Jackpot

250		
20		
5		
10		
100		
20		
5		
10		
100		
20		
5		
10		
100		
20		
5		
10		

15-18
Avg Tix/ Game

2

50¢/250 bonus
2500 Jackpot

250		
10		
3		
5		
100		
10		
3		
5		
100		
10		
3		
5		
100		
10		
3		
5		

17-19
Avg Tix/ Game

3

50¢/1000 bonus
2500 Jackpot

1000		
3		
5		
3		
20		
3		
5		
3		
20		
3		
5		
3		
20		
3		
5		
3		

17-20
Avg Tix/ Game

4

\$1/500 bonus
5000 Jackpot

500		
40		
5		
10		
100		
25		
5		
10		
100		
40		
5		
10		
100		
25		
5		
10		

33-36
Avg Tix/ Game

5

\$1/1000 bonus
2500 Jackpot

1000		
50		
15		
20		
100		
25		
5		
10		
100		
50		
15		
20		
100		
25		
5		
10		

33-35
Avg Tix/ Game

MENU 2- TICKET PATTERNS, cont.

6

\$1/500 bonus
2500 Jackpot



24-27

Avg Tix/ Game

10

1 Euro/1000 bonus
5000 Jackpot



60-66

Avg Tix/ Game

11

30 Pence/250 bonus
1000 Jackpot



8-12

Avg Tix/ Game

12

40 Pence/250 bonus
1000 Jackpot



10-13

Avg Tix/ Game

13

50c/500 bonus
1000 Jackpot

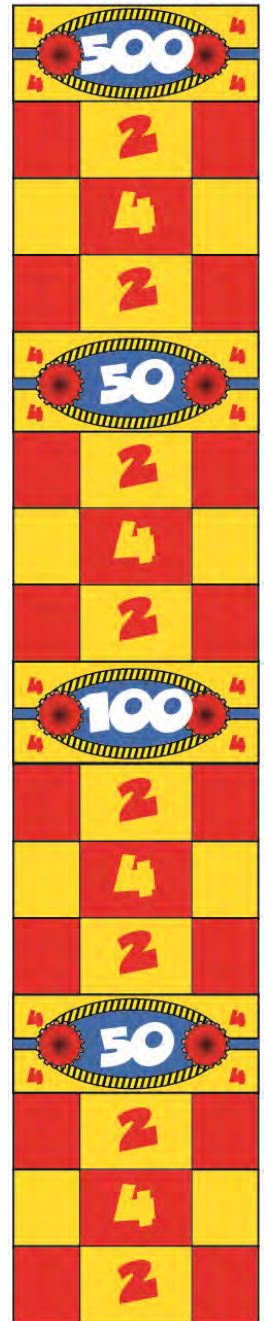

11-13

Avg Tix/ Game

* PATTERNS 7-9 INTENTIONALLY LEFT BLANK

MENU 3– SET JACKPOT VALUE

Scroll through menu 3 with the “menu select” button.
Make your selection by pressing the “menu button” and scrolling through the remaining menus past n8 to exit the menu.

*Factory default settings are highlighted in BLUE.

800	1000	2500	5000
-----	------	------	------

PLEASE CONTACT BAY TEK GAMES SERVICE DEPARTMENT FOR REPLACEMENT BACKLIT DECALS IF YOU DECIDE TO CHANGE THE JACKPOT VALUE

MENU 4– GAME VOLUME

Scroll through menu 4 with the “menu select” button.
Make your selection by pressing the “menu button” and scrolling through the remaining menus past n8 to exit the menu.

*Factory default settings are highlighted in BLUE.

0 (OFF)	1	2	3	4	5	6	7
------------	---	---	---	---	---	---	---

This control is for the volume of the game **while it is being played**, or after a coin has been inserted.

A sample noise will play an example volume while scrolling through the volume levels.

MENU 5– ATTRACT VOLUME

Scroll through menu 5 with the “menu select” button.
Make your selection by pressing the “menu button” and scrolling through the remaining menus past n8 to exit the menu.

*Factory default settings are highlighted in BLUE.

0 (OFF)	1	2	3	4	5	6	7
------------	---	---	---	---	---	---	---

This control is for the volume of the game **while it is NOT being played**.

This game plays fun sounds to lure customers to play.
A sample noise will play an example volume while scrolling through the volume levels.

MENU 6– GOOD SPIN WHEEL SPEED

Scroll through menu 6 with the “**menu select**” button.
Make your selection by pressing the “**menu button**” and scrolling through the remaining menus past n8 to exit the menu.

***Factory default settings are highlighted in BLUE.**

1	2	3	4
----------	----------	----------	----------

MENU 7– PRINTER SETTINGS*

Scroll through menu 6 with the “**menu select**” button.
Make your selection by pressing the “**menu button**” and scrolling through the remaining menus past n8 to exit the menu.

***Factory default settings are highlighted in BLUE.**

0	PRINTER DISABLED
1	PRINTS FOR JACKPOT VALUES ONLY, TICKETS DISPENSE FOR ALL OTHER VALUES
2	PRINTS FOR VALUES OF 250 AND ABOVE, TICKETS DISPENSE FOR ALL OTHER VALUES
3	PRINTS FOR VALUES OF 100 AND ABOVE, TICKETS DISPENSE FOR ALL OTHER VALUES

***Printers for Crank It Revolution are a factory option.**

If you choose to add printers to your game, call our service department to order a printer kit -
Part # AAPR-CIR

See “How to Install Printer” section on pages 35-36.

MENU 7– WHEEL POSITION DIAGNOSTICS

While in wheel position diagnostics, turn the wheel down towards you to view the position of each space on the wheel. The count should start at 0 on the decal seam, and count up to 24.

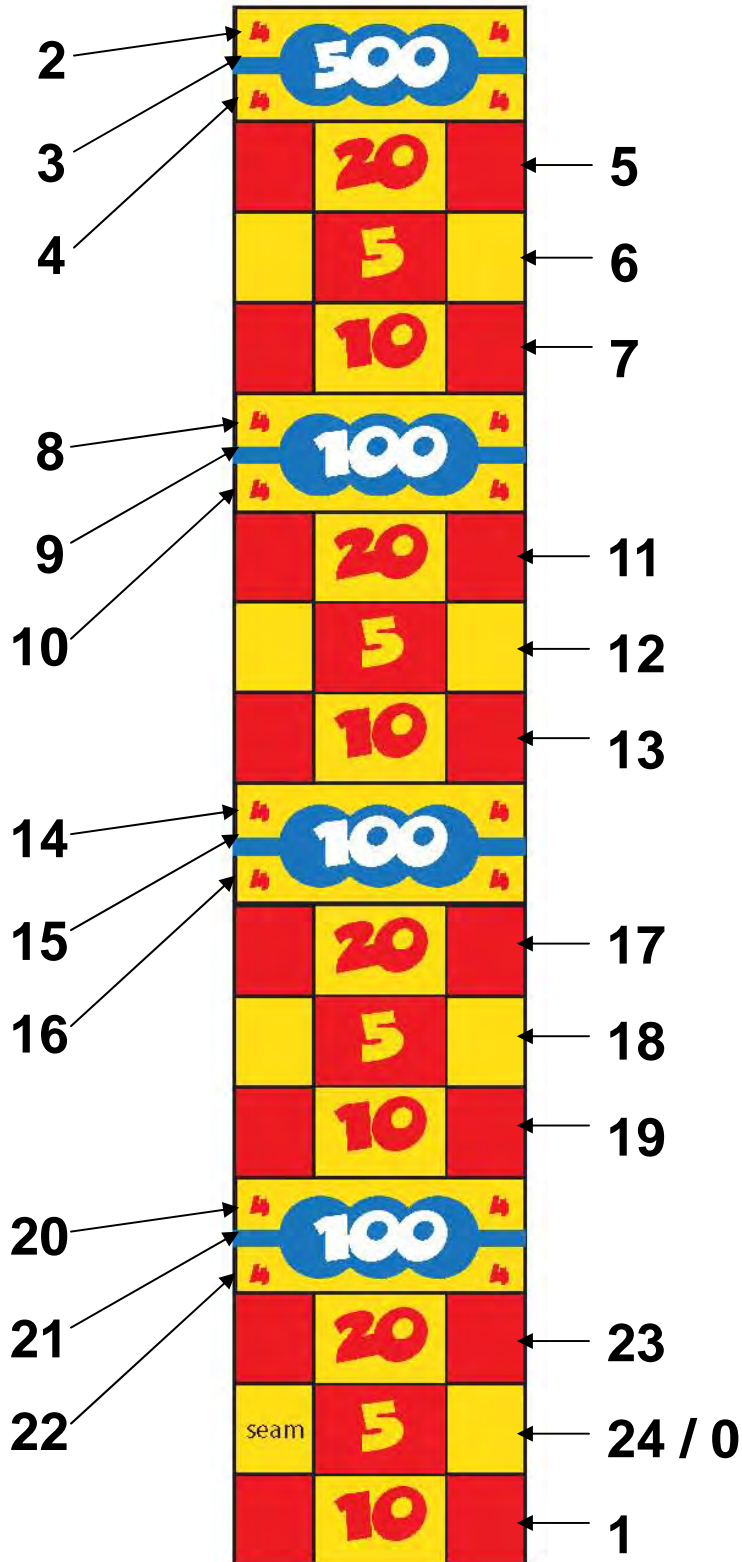

MENU 8— TICKET VALUE DIAGNOSTICS

While in ticket value diagnostics, the dot-matrix display should show the same number as the wheel as you turn it towards you.



CIRCUIT BOARD WIRING

AANEWGEN1 - MAIN BOARD

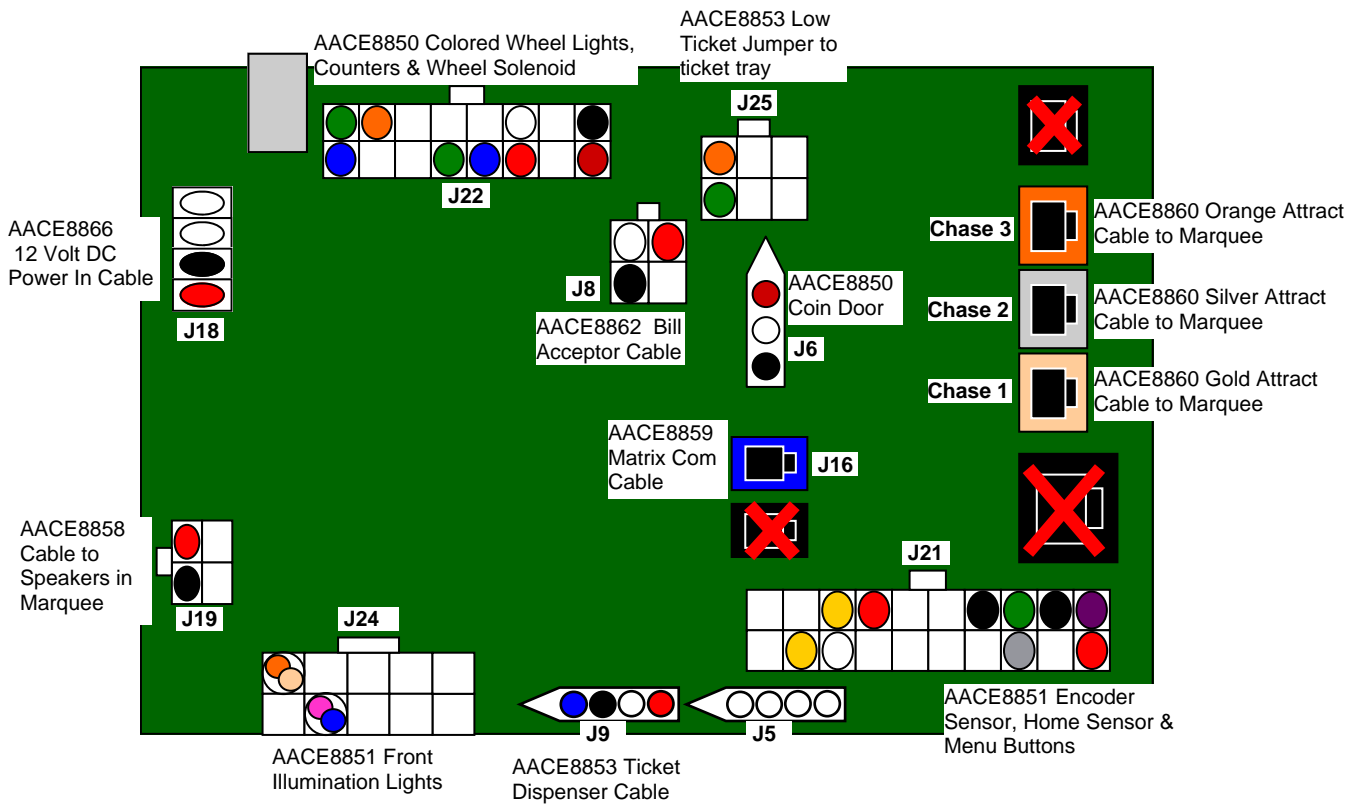

AACB8854- MARQUEE CONTROLLER BOARD

AACB8856- DUAL PRINTER CONTROL BOARD (OPTIONAL)

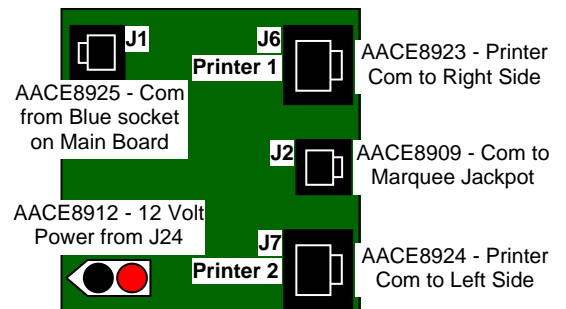
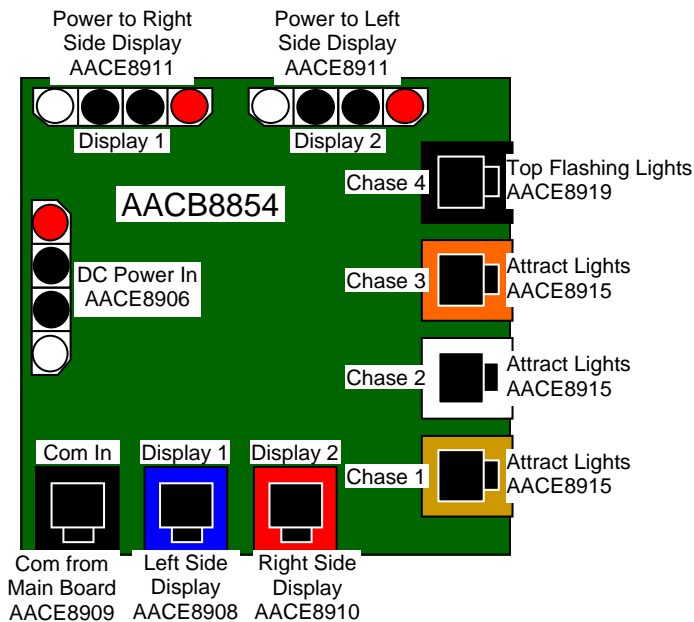

AACE8912- J24, J19, J18 CONNECTORS AC POWER, DC POWER, SPEAKERS, LIGHTING

MARQUEE- TOP OF GAME

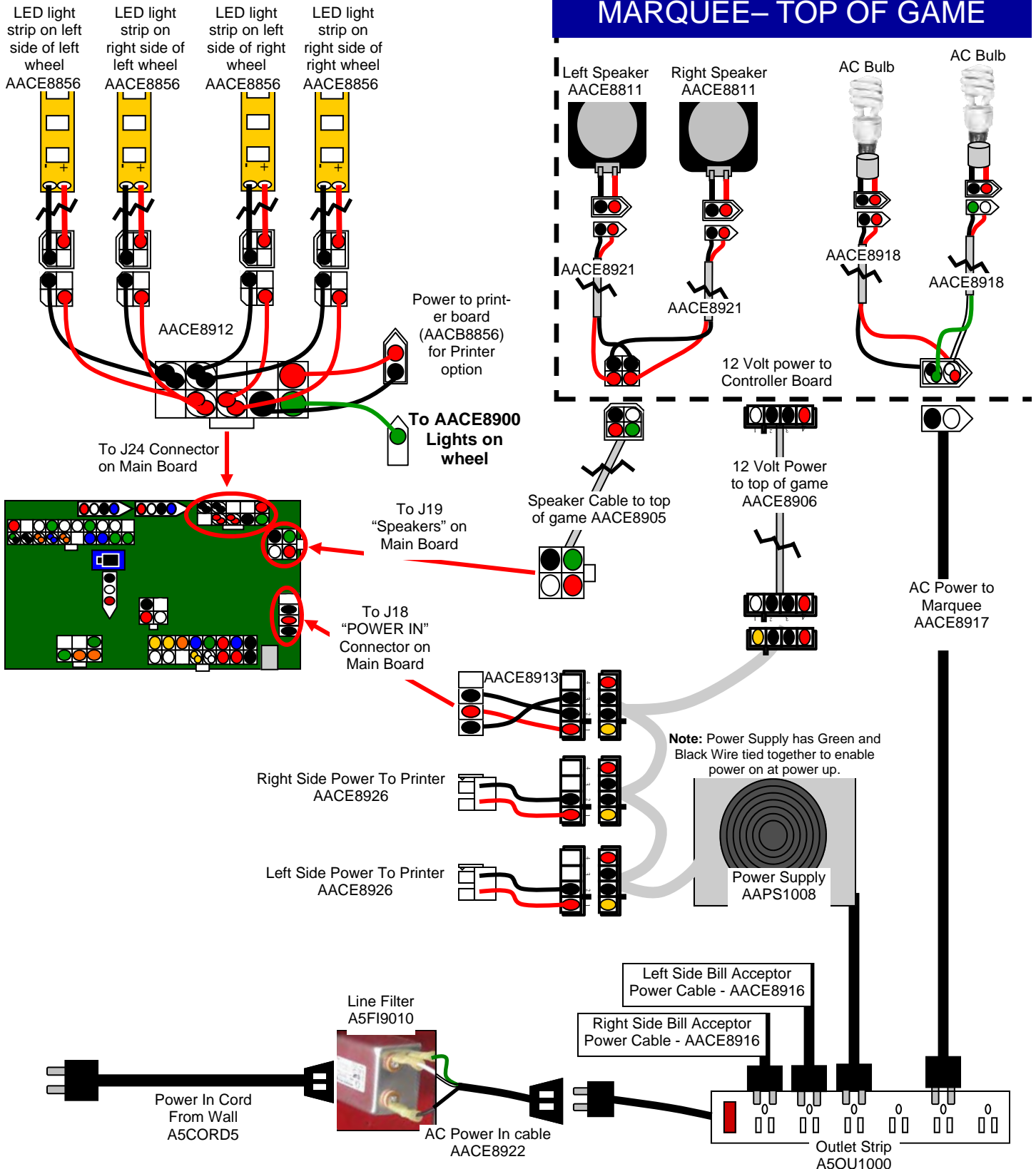

ACE8904/ACE8901– J5, J9, J25 CONNECTORS TICKET DISPENSERS, LOW TICKET SWITCH, WHEEL SOLENOID

LEFT SIDE WHEEL

RIGHT SIDE WHEEL

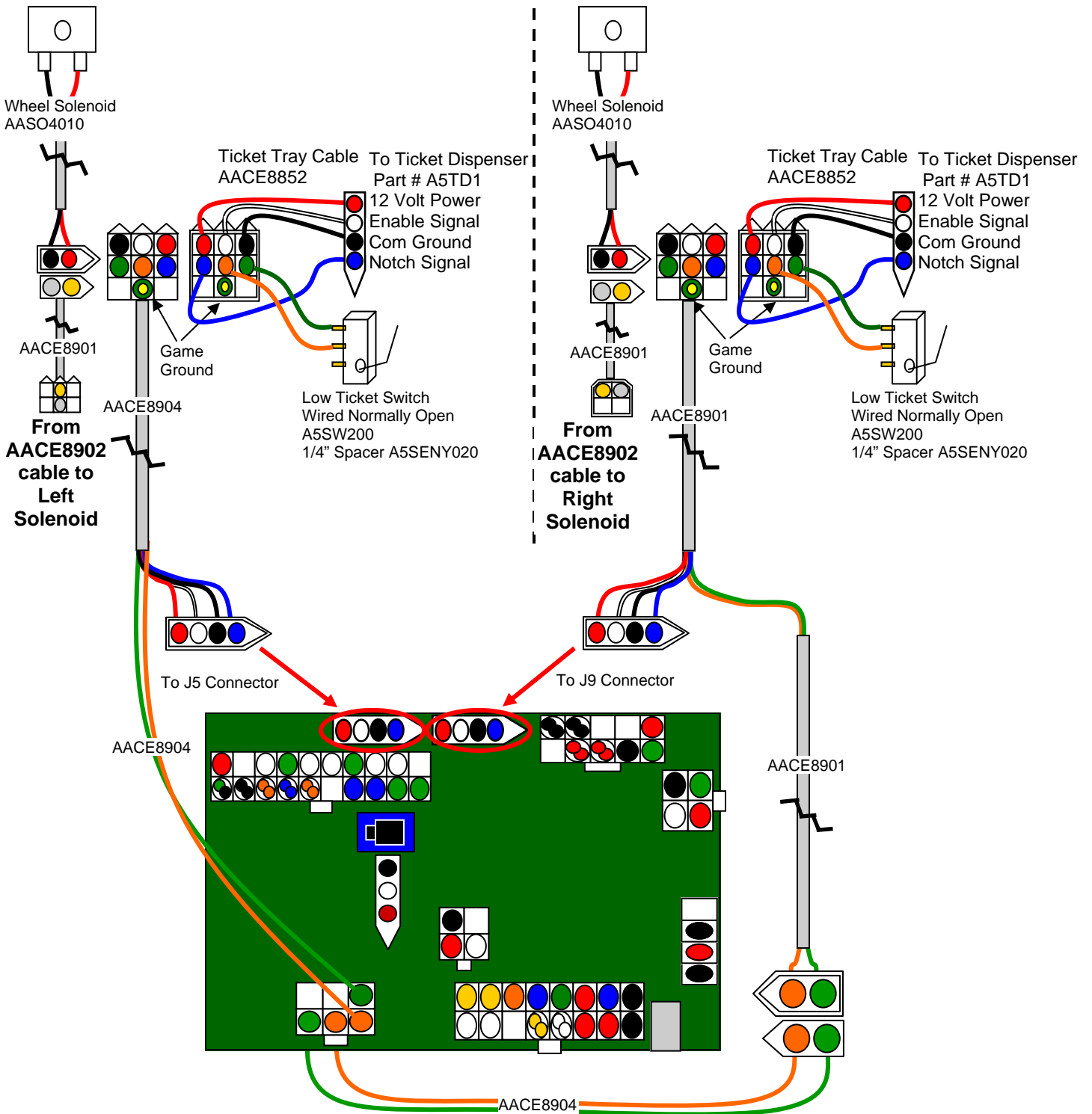

ACE8902/ACE8900- J22 CONNECTOR SENSORS, MENU BUTTONS, WHEEL SOLENOID

LEFT SIDE WHEEL

RIGHT SIDE WHEEL

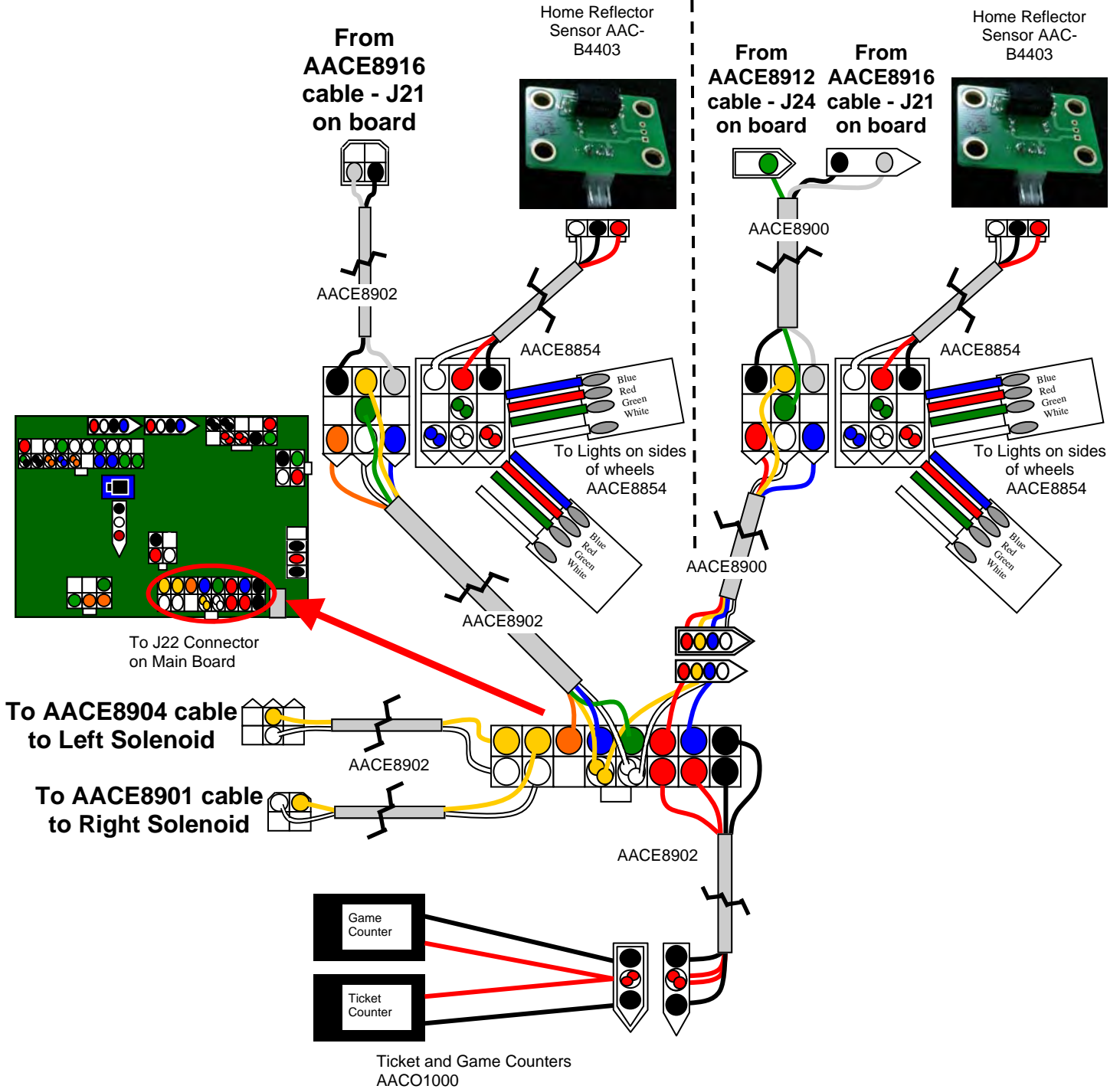

AACE8916- J21 CONNECTOR COIN MECHS, DBAS, MENU BUTTONS, WHEEL SENSORS

RIGHT SIDE WHEEL

LEFT SIDE WHEEL



Encoder Sensor in Front Arrow AAC-B8852

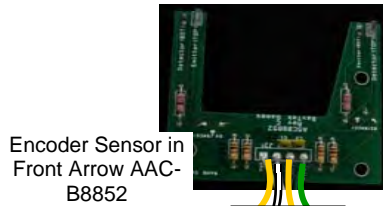

Encoder Sensor in Front Arrow AAC-B8852

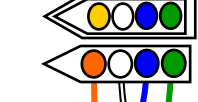

Encoder Sensor in Front Arrow AAC-B8852

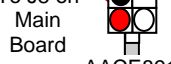
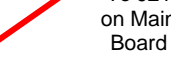
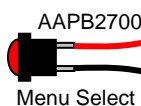
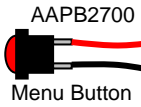

To J21 on Main Board

To AACE8900 cable to Right Side Home Sensor

To AACE8902 cable to Left Side Home Sensor

To Bill Acceptor on Left Side

To Bill Acceptor on Right Side

AACE8916

AACE8916

LEFT DBA CABLE

RIGHT DBA CABLE

To J6 on Main Board

To J8 on Main Board

AACE8916

AACE8916

AACE8916

AACE8916

AACE8916

AACE8916

AACBL4A-DOOR

AACBL4A-DOOR

LEFT COIN DOOR

RIGHT COIN DOOR

AACE8909- J18 CONNECTOR PRINTER WIRING OPTIONS

J18 WIRING- NO PRINTERS

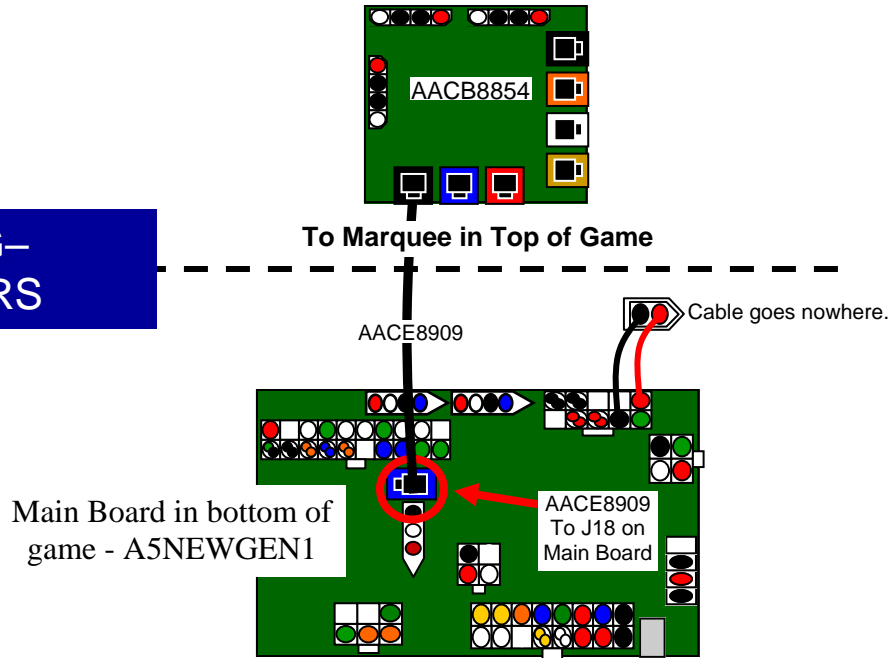

J18 WIRING- WITH PRINTERS

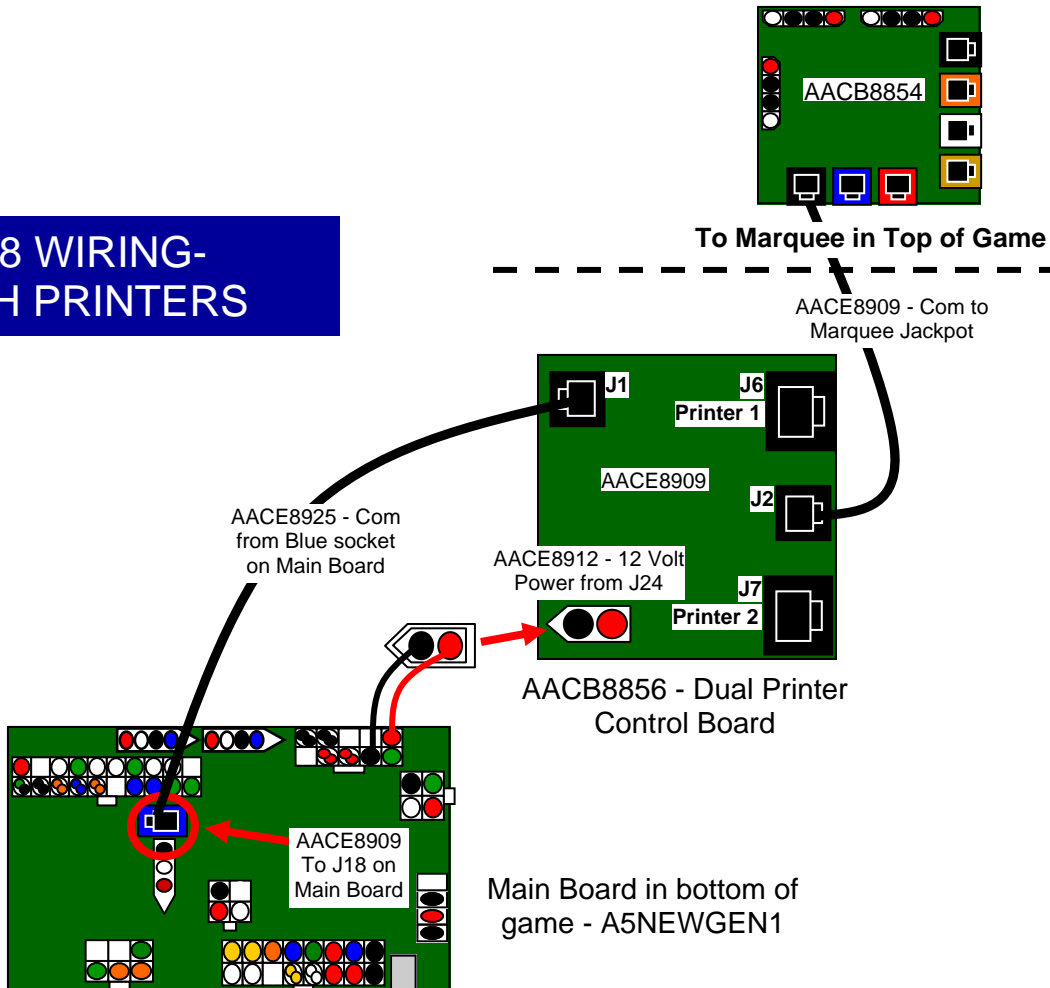

TROUBLE SHOOTING GUIDE



Troubleshooting Strategy

Use common sense and a systematic method of troubleshooting to determine the exact problem, probable cause and remedy. Use the process of elimination to find the faulty component. Always check for the simple and obvious causes first such as unplugged, loose or broken wires and bad sensors, bent, pinched, stuck or jammed components.

Troubleshooting Chart

Problem	Probable Cause	Remedy
<p>No power to the game. No lights on at all.</p>	<p>Unplugged. Circuit breaker tripped. Power strip faulty. Faulty cable/power supply.</p>	<p>Check wall outlet. Reset power strip breaker switch or building circuit breaker. Change plug position, replace if needed. See Power Supply diagnostic below.</p>
<p>AC Light and Bill Acceptor on; everything else off. (Power Supply not ON)</p>	<p>Power supply unplugged. Rocker Switch turned off. Power supply shutting down because of 12 V overload. Faulty power supply.</p>	<p>Ensure unit is plugged into power strip. Make sure rocker switch is set to ON.  See power supply diagnostics to isolate bad component. A bad motor or 12 volt short would cause this. See Power Supply Diagnostic below.</p>
<p>Dollar Bill Acceptor not functioning.</p> <p>Ensure Bill Acceptor is set to "Always Enable"</p>	<p>Check for power to Bill Acceptor. Dirt or debris in acceptor slot. Pinched, broken, or disconnected wiring. Bill acceptor problem.</p>	<p>Acceptor should cycle stacker at game power up. If not, check cable connections. Refer to "How to Clean Bill Acceptor" Or clean with bill reader cleaning card. (A5CC9000) Check wiring from bill acceptor to Main Board. (AACE8862) Repair or replace wiring harness. Check J8 connector on Main Board Make sure wires are secure in connectors. Refer to troubleshooting section of dollar bill acceptor manual included with this game or the diagnostics label on the back of the unit.</p>
<p>Game not coining up.</p>	<p>Ensure game makes sound when coin switch is triggered. Game set to large amount of credits per game.</p>	<p>Check coin switches—both should be wired normally open. If one switch is "closed" the other will not work either. Check wiring to main board. Cable AACBL4A-DOOR, AACE8850 Jackpot display will show credits inserted. Enter N1 mode in menu to set credits per game.</p>

TROUBLE SHOOTING GUIDE

Problem	Probable Cause	Remedy	
Scoring Issues  Encoder sensor not seeing wheel spin.	Encoder sensor dirty or faulty. Sensor is being interfered with. Pinched, broken, or disconnected wiring. Faulty Main Board	Clean sensor and replace if needed. (AACB8852) Remove game from direct sunlight, move game to area away from neon lights or bright fluorescent lights. Inspect wiring and replace cable if needed. AACB8852, AACE8851 Refer to Encoder Sensor Test below.	
	Game says you won even though wheel is still spinning.	Brake Assembly tension set to loose.	Refer to "How to Set Brake Tension"
	Wheel values, arrow pointer and payout are off slightly.	There is an adjustment on the wheel encoder sensor to calibrate the monitor change to where the arrow is pointing.	Refer to "How to adjust wheel sensor"
Game is giving wrong tickets values. Enter Diagnostic Menu on MENU 6 and watch dot matrix display as you spin the wheel downward. *Remove game from direct sunlight, move game to area away from neon lights or bright fluorescent lights.	Wheel Position does not change as you spin the wheel down.	Encoder sensor unplugged, dirty or faulty. Clean and replace if needed. (AACB8852) Inspect wiring, refer to Encoder Sensor Test below.	
	Wheel Position does change as you spin the wheel down.	If Wheel Position goes to 24, then resets to 0 and continues up again. Encoder sensor out of adjustment. Refer to "How to adjust wheel sensor"	
		If Wheel Position increments constantly upwards up past 100. Home Position sensor unplugged, dirty or faulty. Clean and replace if needed. (AACB4403) Inspect wiring. Cable #'s AACE8854, AACE8850 Wrong ticket pattern selected. Enter menu and go to MENU 2. Verify correct ticket pattern.	
Display shows "LOW TKTS" 	Ticket tray is empty. Disconnected, loose or broken wires. Faulty low ticket switches. Faulty Main Board.	Refill tray with tickets, check low ticket switch. Check connections and reseal J25 on main board. Cable #'s AACE8852, AACE8853 Switches wired normally open. Replace switches. A5SW200 Replace main board. Part # AANEWGEN1	

TROUBLE SHOOTING GUIDE

Problem	Probable Cause	Remedy
<p>Wheel not spinning when player moves handle.</p> <p>Check for 12 Volts DC at coin up on connector.</p>	<p>No 12 Volts on connector at coin up.</p>	<p>Inspect cable from Solenoid to main board. (J22) Cable part #'s: AACE8869, AACE8850</p> <p>Replace main board. (AANEWGEN1)</p>
	<p>12 Volts present at connector, but solenoid still doesn't engage.</p>	<p>Inspect cable as far into wheel as possible. Look for broken or stretched wires. Repair if possible.</p> <p>Wheel will have to be removed to further inspect or replace. Refer to "How to Remove Wheel"</p>
<p>Solenoid always stays on.</p> <p>Players can continue to spin wheel after "good spin", allowing them to nudge it to the bonus space.</p> <p>Players will win a lot!</p>	<p>Jammed Solenoid or Springs</p> <p>Pinched Cable.</p> <p>Check for 12 Volts DC on cable to solenoid when game on, but not coined up in game play.</p>	<p>Inspect solenoid. Ensure it operates smoothly. Press in on silver bar. It is spring loaded and will spring back after release.</p> <p>Inspect cable for smashed wire. May also have to replace main board.</p> <p>If 12 Volts present, Replace main board. (AANEWGEN1)</p> <p>If no 12 Volts and solenoid is still engaged – Wheel will have to be removed to further inspect or replace. Refer to "How to Remove Wheel"</p>

POWER SUPPLY DIAGNOSTICS

Check power cable into back of game.

Check AC cord from power strip in game.

Verify power strip rocker switch is ON.
(Switch cord into different socket in power strip)

Check AC connection to power supply.

Ensure Power Supply switch is set to 115V
(Some power supplies may not have this)

Ensure Power switch is on.

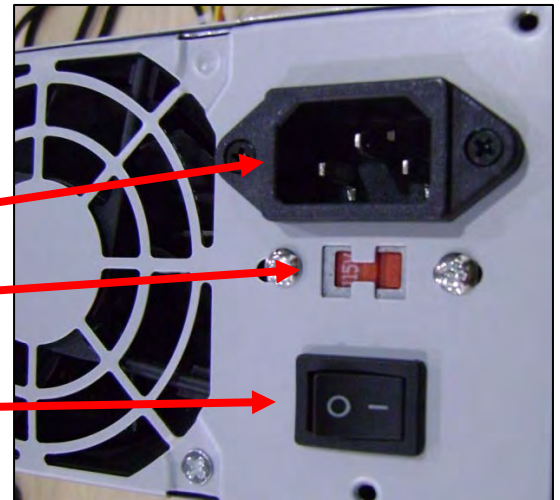

Check if Power Supply Fan is turning:

If Fan is turning:
Power supply is working. If game still has no 12 Volts DC, then Power Supply is faulty.
Replace Power Supply. AAPS1008

If Fan is not turning:

Turn power OFF. Disconnect all 12 volt output wires from power supply only. Turn power ON.

Fan turns.

Fan does not turn

Replace Power Supply.
(AAPS1008)

Turn power OFF. Unplug all outputs from the large PCB. Reconnect the 12 volt output wires from Power Supply to PCB main board. Turn power ON.

Fan turns.

Fan does not turn.

Short in PCB - Replace.

Turn power OFF. Reconnect the outputs at the PCB one at a time. Wait 60 seconds between tests to turn power ON.

Fan does not turn.

That cable or related component is shorted out or causing an overload. See Jumper Cable Pin-Outs to see which component might be at fault.

Fan turns.

That cable is OK.

BILL ACCEPTOR DIAGNOSTICS

Note: There are many different models and brands of Bill Acceptors that are used on redemption games. Your Bill Acceptor may differ from the unit shown.

First determine if Bill Acceptor has power:

Turn game ON—The bill acceptor should make noise as stacker cycles and green lights on outside bezel should flash.

If NO power:

Due to the different models and brands of Bill Acceptors that are used: Examine Bill Acceptor and determine if acceptor is 12 Volt DC or 110 VAC Use meter to measure voltage at cable going into Bill Acceptor.



If power is OK:

Clean Bill Acceptor path to make sure there is nothing jamming unit.

Enter DBA Diagnostics Mode -

Important—Do not hold button down too long or Bill Acceptor will enter programming mode.

If accidentally entered programming mode by mistake—Unplug game and plug back in.

To enter Diagnostic Mode, press and hold the Diagnostic Button on the back left corner of the DBA for **1-3 seconds.**

The lights above the bill slot will flash the code.

ERROR CODES

Count the number of flashes on front bezel of Bill Acceptor and follow chart for repair.

FLASHING CODE	DESCRIPTION	CORRECTIVE ACTION
LEDs off	Power off	Turn on power
LEDs on	Acceptor is OK	
1 flash	Bill path blockage	Un-jam bill path
2 flashes	Stacker jam	Un-jam stacker
3 flashes	Cassette is full of bills	Empty the cassette
4 flashes	Cassette is removed	Replace the cassette
5 flashes	Acceptor is defective	Replace the acceptor
6 flashes	Acceptor not enabled	See service manual
10 flashes	Configuration Mode	Power down to exit
Rapid flashing during operation	Stringing attempt detected; or sensors dirty	Clean the sensors



HOW TO: Change Arrow Position

1. Slide open the cabinet window



2. Remove the nuts and washers from the 3 bolts shown and set aside

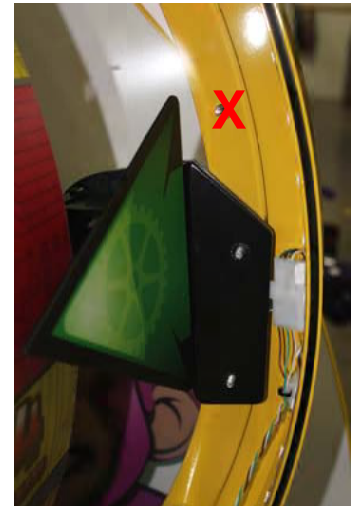

3. Move the entire arrow assembly down to the second set of bolts

4. Re-secure the lock nuts, adding a washer to the now-empty bolt



5. Close the window

6. Open the front door of the cabinet to access the main board

7. Turn dip switch 2 to the correct position (see page 7)

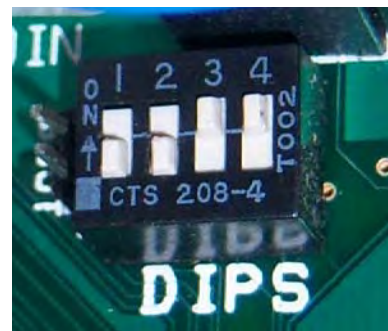

HOW TO: Adjust Wheel Sensor

Wheel sensor is located behind the arrow on wheel.

It “reads” the notch in the side of the wheel to tell the game when the panel has changed.

To Test:

Enter menu and go to MENU 8.

Spin Wheel slowly downward, and watch display’s wheel position readout.

The wheel position value should change as soon as next panel crosses arrow point.

To Adjust:

Turn Phillips head screw to move sensor.

Continue spinning wheel slowly downward, and watch display’s wheel position readout; adjusting screw until panel changes at arrow.



Part #'s:

Pointer Assy. AAPO8800

Sensor alone - AACB8852



HOW TO: Clean Game

Use a mild soap solution and a clean lint free cloth to wipe down game.
Do NOT use any cleaning solvents on the game’s graphics!



Front Plexi will slide up. (Like a roll top desk)

How to:

Open front door and unclip
2 latches holding window
bracket.



Push up on bracket, and roll plexi upwards.

Clean inside of plexi with lint free cloth or “swiffer”
duster.

HOW TO: Set Brake Tension

To Test:

Turn off game and flip dipswitch #4 ON.
Turn game on.

The display will show "TEST BRAKE"

Use plunger handle to give the wheel a good spin, Let the wheel coast to a stop like a normal game play.

If brake is set correctly, screen will show a number between 50 - 70.

If less than 50: Loosen Brake

If greater than 70: Tighten Brake



To Adjust:

To loosen brake:

Loosen top nut and move 1/4 inch up. The threaded rod will drop as top nut moves up. Spin bottom nut up tight to bracket. Tighten both nuts.

To tighten brake:

Loosen bottom nut and move 1/4 inch down. Lift up the threaded rod and spin nut down tight to bracket. Tighten both nuts.

Re-test to verify.

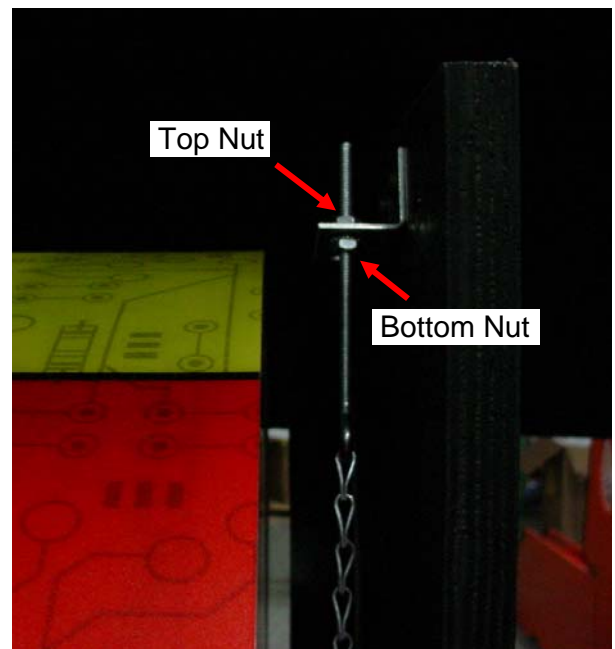

HOW TO: Change Ticket Pattern



Slide up front plexi to access wheel by opening front door and unclipping 2 latches holding window bracket. Push up on bracket, and roll plexi upwards.



Press Menu Button and go to MENU 8 Mode.

Slowly spin the wheel down while watching display. This number will match the number on the wheel.



Determine which ticket pattern to purchase:

Reference ticket patterns below—Note the approximate tickets per game for each pattern.

Purchase cover up decals.

1	2	3	4	5	10	11	12	13
50c/250 bonus 1000 Jackpot	50c/250 bonus 2500 Jackpot	50c/1000 bonus 2500 Jackpot	\$1/500 bonus 5000 Jackpot	\$1/1000 bonus 2500 Jackpot	1 Euro/1000 bonus 5000 Jackpot	30 Pence/250 bonus 1000 Jackpot	40 Pence/250 bonus 1000 Jackpot	50c/500 bonus 1000 Jackpot
250 20 5 10 100 20 5 10 100 20 5 10 100 20 5 10	250 10 3 5 5 100 10 3 5 5 100 10 3 5 5 100 10 3 5	1000 3 5 5 20 3 5 3 20 3 5 3 20 3 5 3	500 40 5 10 100 25 5 10 100 40 5 10 100 25 5 10	1000 50 15 20 100 25 5 10 100 50 15 20 100 25 5 10	1000 25 50 25 100 25 150 25 100 25 50 25 150 25	250 3 5 3 50 2 4 2 50 3 5 3 50 2 4 2	250 10 3 5 50 10 3 5 50 10 3 5 50 10 3 5	500 2 4 2 50 2 4 2 100 2 4 2 50 2 4 2
15-18 Avg Tix/ Game	17-19 Avg Tix/ Game	17-20 Avg Tix/ Game	33-36 Avg Tix/ Game	33-35 Avg Tix/ Game	60-66 Avg Tix/ Game	8-12 Avg Tix/ Game	10-13 Avg Tix/ Game	11-13 Avg Tix/ Game

* PATTERNS 6-9 INTENTIONALLY LEFT BLANK

Install cover up decals:

Press Menu Button and go to MENU 2 Mode.

Change number to desired Ticket Pattern as it shows on display.

Press Menu Button and go to MENU 6 Mode.

Spin wheel downward slowly one complete revolution

This number will show the new ticket value on the wheel.



Place new decal carefully over value on wheel.

Note: Be careful to not rock wheel backwards over a notch, or the position will be off.

If it does rock backward, spin wheel downward one complete revolution to allow wheel to calibrate.

Continue applying new decals carefully until wheel is complete.

HOW TO: Remove Wheel

The wheel will have to be removed to access engaging solenoid to repair/replace.

Step 1:
Remove the back door from the game using a 644 key.



Step 2:
Remove the top back from the game.
There are 4 screws on top of the game to remove.
Inside the game there are 2 screws on the LEFT and 2 screws on the RIGHT to remove. (RIGHT side screws shown below)

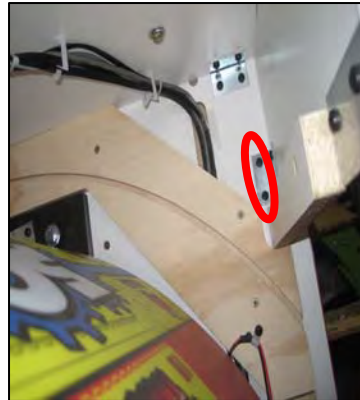

Step 3:
Unplug the 8850-1 and the 8850-3 cables.
Remove the 3 cable clamps from the board on the RIGHT side.



Step 4:
Remove the screws from the upper and lower side boards from the LEFT and RIGHT side of the game.
Remove the boards.



Step 5:
Remove the pin from the linkage below the wheel on the RIGHT side.
Separate the linkage after removing the pin.



Step 6:
Remove the upper and lower bolts from the sides of the wheel cradle.



HOW TO: Remove Wheel

Step 7:

Move around to the front of the game and open the front door. Reach inside the game and unlatch both front window locks. Raise the window so you can easily access the arrow.

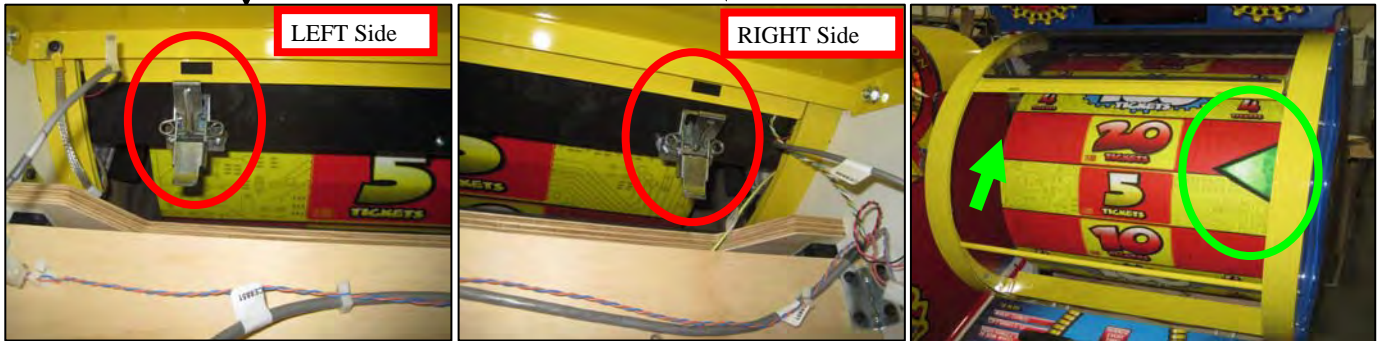

Step 8:

Unplug the arrow sensor cable.
Remove the 2 nuts from the arrow bracket.



Step 9:

Remove the arrow assembly from the game. Be careful not to damage the sensor when removing the arrow.

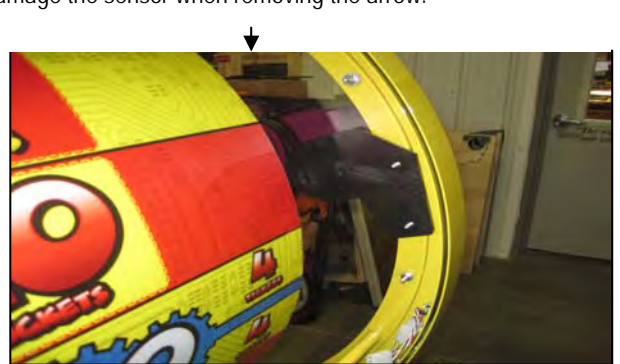

Step 10:

Close the front window.



Step 11:

Move around to the back of the game.
Begin to slide the wheel assembly straight back.
When it gets about half way out, lean it back and lift it out of the game to remove.

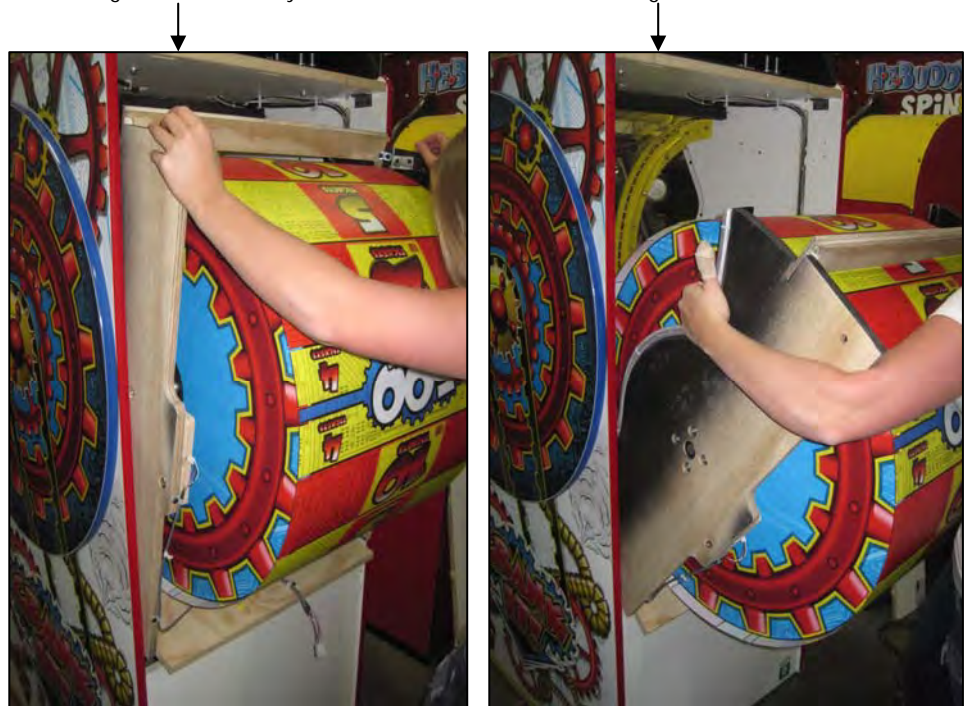

HOW TO: Install Printer

***Printers for Crank It Revolution are a factory option.**

Parts included in Kit:

- 2 of A5PRTH003 - Printers
- 2 of A5PYTH010 - Rolls of Paper
- 2 of A5HLPR001 - Paper Holders
- 2 of A5PL8902 - Metal Mounting Plates
- 1 of AACB8856 - Printer Controller Board
- 1 of AACE8923 - Cable from Controller Board to Right Side Printer
- 1 of AACE8924 - Cable from Controller Board to Left Side Printer
- 1 of AACE8925 - Jumper from Blue Socket on Main Board to Controller Board
- 2 of AACE8926 - Power Cable from Power Supply to Printers

If you choose to add printers to your game, call our service department to order a printer kit -

Part # AAPR-CIR

1.) Remove the printer parts from the box and assemble both printers.



Attach the core holder to the arm using the large screw provided.

Attach the arm to the printer body using the 3 smaller screws. **BE SURE TO INSTALL IT ON THE CORRECT SIDE**, as shown.

Use a zip tie to manage the cable, as shown.

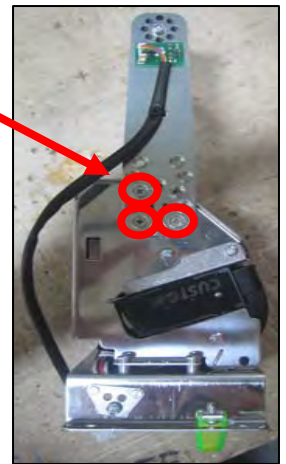

Place a side piece onto the core holder.



Place the paper roll onto the core and then snap the final side piece onto the holder.



Note: Paper must feed under holder and into printer

HOW TO: Install Printer, cont.

2.) Install Printers on both doors.

Open front doors and remove blanking plate (Part # A5PL8901)

Install new printer plate on cabinet. (Part # A5PL8902)



Install printers on doors.



3.) Install Dual Printer Control Board and wiring.

Control Board is mounted above power supply in front of game.

Standoff's are included in kit.

Plug both AACE8926 cables into spare power supply cables.

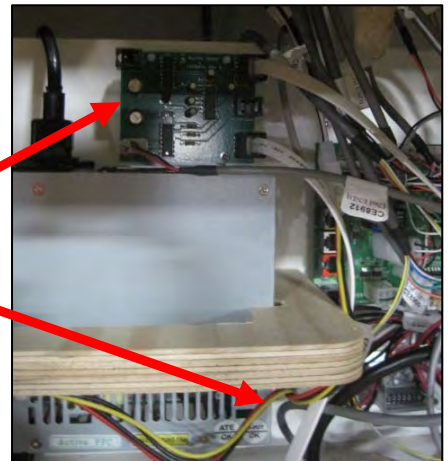

AACE8925 - Com from Blue socket on Main Board

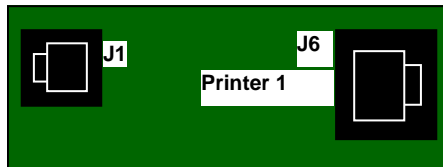

AACE8923 - Printer Com to Right Side

AACB8856 - Dual Printer Control Board

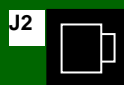

AACE8909 - Com to Marquee Jackpot

AACE8912 - 12 Volt Power from J24

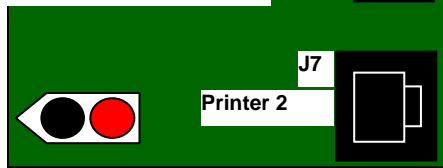

AACE8924 - Printer Com to Left Side

3.) Route Wiring to both Printers.

Route both the phone cable and the power cable to both printers, making sure that the cables will not get pinched by doors and mechanisms.



Left Door
AACE8924 & AACE8926

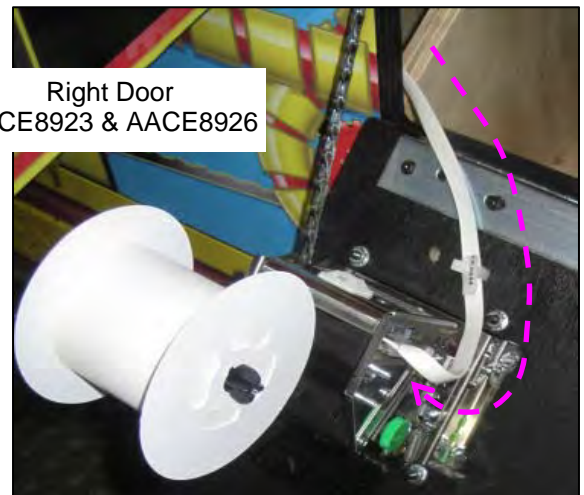

Right Door
AACE8923 & AACE8926

PIVOT ASSEMBLY DIAGRAM



Pivot Assembly Crank It & Crank It Revolution Exploded View Diagram

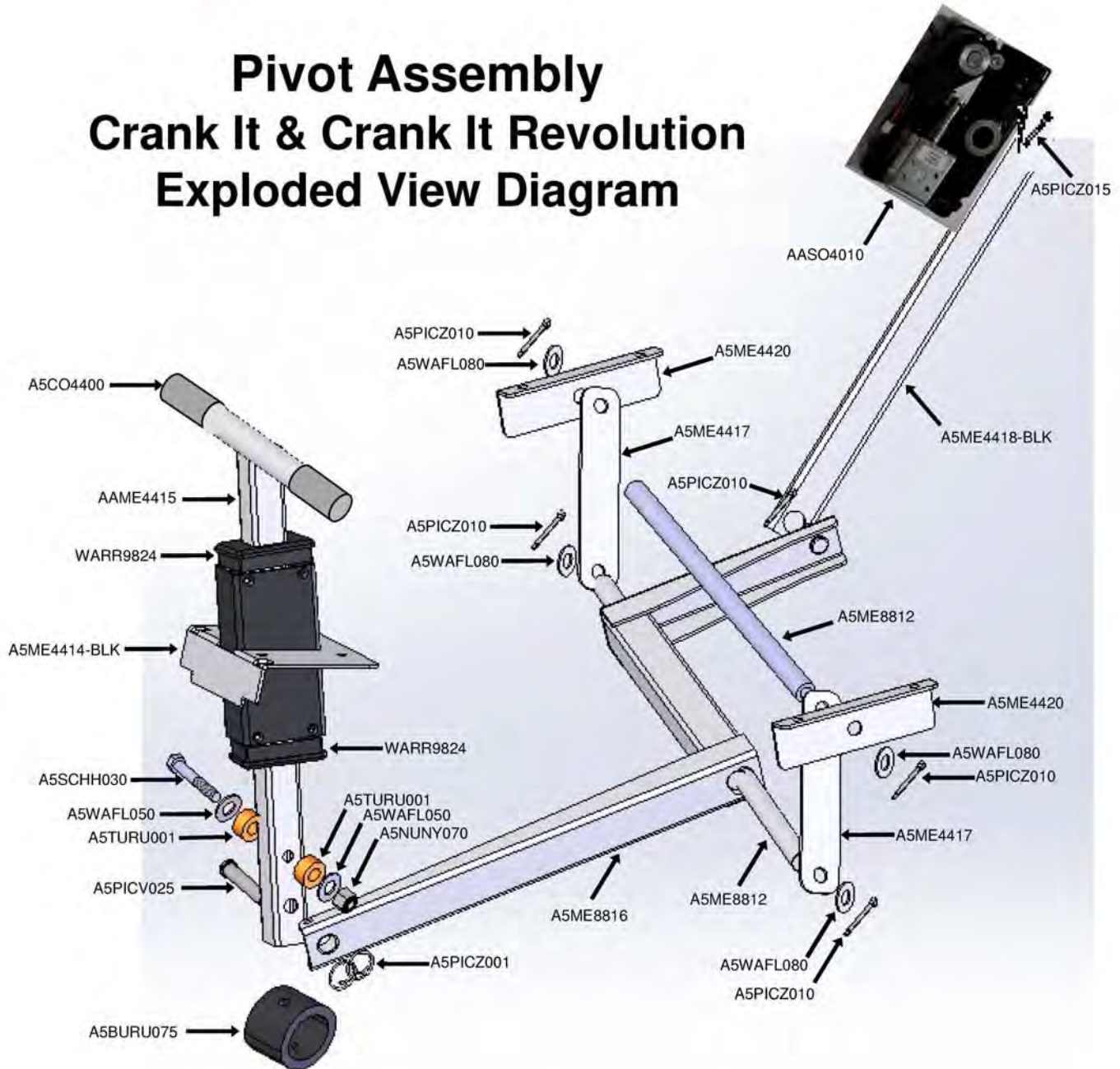

If you have any questions or need further assistance please contact Baytek Games at 920-822-3951 Ext 1102

PARTS LIST

PART #	DESCRIPTION	PART #	DESCRIPTION
A5BURU075	Rubber Bumper	A5DE8801-1	Pointer Decal
A5CB1499	Cash Box	A5DE8802-1	Right Side Wheel Decal
A5CO4400	Handle Grips	A5DE8803-1	Left Side Wheel Decal
A5CORD5	Computer Cord	A5DE8804-1	Right Side Top Decal
W5TM4002	Blue T-Molding 13/16"	A5DE8805-1	Left Side Top Decal
A5FI9010	Inline Filter	A5DE8806-1	Right Side Middle Decal
A5LI0001	120 Volt Fluorescent Light	A5DE8807-1	Left Side Middle Decal
AAGU4401	Wire Guard	A5DE8814-1	Right Side Marquee Decal
A5LK2000	Lock, 631	A5DE8815-1	Left Side Marquee Decal
A5LK5001	Lock, 644	A5DE8817-1	Small Marquee Gear Decal
9654K191	Spring	A5DE8818	Large Left Marquee Gear Decal
A5ME4167	Metal Solenoid Link	A5DE8819	Large Right Marquee Gear Decal
A5ME4180	Metal Right Ticket Tray	A5DE8900	Left Marquee Gear Decal
A5ME4414-BLK	Metal Handle Guide	A5DE8902	Wheel Seam Decal
AAME4415	Metal T-Handle	A5DE8903	Control Panel Decal
A5ME4417	Metal Pivot Link	A5DE8904	Main Front Cabinet Decal
A5ME4420	Metal Pivot Link Bracket	A5DE8905	Coin Door Decal
A5ME4422	Metal Wheel Mounting Bracket	A5DE8906	Left Ticket Door Decal
A5ME4429	Metal Solenoid Bracket	A5DE8907	Right Ticket Door Decal
A5ME4430	Metal Slip Clutch Bracket	A5DE8908	Left Coin Mech Door Decal
A5ME8800	Metal Wheel Shaft	A5DE8909	Right Coin Mech Door Decal
A5ME8802	Metal Curved Glass Rail	A5DE8910	Bottom Right Side Cabinet Decal
A5ME8806	Metal Sliding Window Handle	A5DE8911	Bottom Left Side Cabinet Decal
A5ME8807	Metal Sliding Window Bracket	A5DE8912	Jackpot Marquee Decal
A5ME8812	Metal Handle Rod	A5DE8913-2500	Jackpot Value Marquee Decal
A5ME8814	Metal Side Guard	A5DE8914	Backlit Logo Decal
A5ME8816	Metal Rocker Arm	A5DE8915	Option Menu Decal
A5PL9097	Plate Replaces Bill Acceptor	A5DE8919	Right Marquee Gear Decal
A5SW200	Switch	A5DE8901	Default Big Wheel Decal
A5TT4102	Ticket Tray	AADE8923	Ticket Cover Up Pattern #1
A5TT4103	Left Long Ticket Tray	AADE8924	Ticket Cover Up Pattern #3
A5TU4400	Clear Tubing	AADE8921	Ticket Cover Up Pattern #4
AACP8901	Metal Control Panel With Decal	AADE8925	Ticket Cover Up Pattern #5
AADO8905	Cash Box Door With Decal	AADE8922	Ticket Cover Up Pattern #10
AADO8906	Left Ticket Door With Decal	AADE8926	Ticket Cover Up Pattern #11
AADO8907	Right Ticket Door With Decal	AADE8927	Ticket Cover Up Pattern #12
AADO8908	Left Coin Mech Door With Decal	AADE8928	Ticket Cover Up Pattern #13
AADO8909	Right Coin Mech Door With Decal		
AAPO8800	Pointer Assy.		

PARTS LIST

PART #	DESCRIPTION	PART #	DESCRIPTION
AACB4403	Reflective Sensor	AAPB2700	Push Button with Cable
AACB8850	Circle Light	AACBL4A-DOOR	Coin Door Cable
AACB8851-1	Display Board	AACE1710	Door Ground Cable
AACB8852	Encoder Sensor	AACE1715	Ground Strap Cable
AACB8853	Speaker Light Board	AACE8811	Speaker with Cable
AACB8854	Marquee Controller Board	AACE8852	Ticket Tray Cable
AACB8855	Chaselight Board (3 Per)	AACE8853	Mini Gen 1 to Ticket Jumper Cable
AANEWGEN1	Mini Gen 1 (main board)	AACE8856	Wheel Lights Cables
		AACE8861	Ground to Front Door Cable
		AACE8865	Coin Door Ground Cable
		AACE8900	Right Wheel Cable
		AACE8901	Left Ticket Dispenser Cable
		AACE8902	Left Wheel Cable
		AACE8903	Light Jumper Cable
		AACE8904	Ticket Tray Cable
		AACE8905	Volume Cable
		AACE8906	Aux Board Power Cable
		AACE8907	12 Volt Power Cable
		AACE8908	Display Jumper Cable
		AACE8909	Main Board to Aux Board Cable
		AACE8910	Display Jumper Cable
		AACE8911	Bonus Light Cable
		AACE8912	LED Light Cable
		AACE8913	Counter Cable
		AACE8914	Gear Driver Cable
		AACE8915	Marquee Controller Board
		AACE8916	Coin Door Cable
		AACE8917	Marquee Light Cable
		AACE8918	Ceramic Light Cable
		AACE8919	Chaselight to Aux Board Cable
		AACE8921	Speaker Cable
		AACE8922	Line Filter Jumper Cable
		AACO1000	Counter Assembly
		A5TD1	Ticket Dispenser
		AABK8800	Brake Assy.
		AASO8800	Solenoid Assembly With Cable
		AAPPS1008	Power Supply

PARTS PICTURES



AACB8852



AACB4403



AACB8851-1



AACB8853

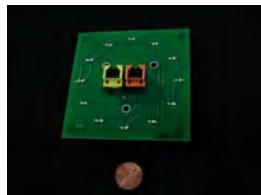

AACB8850



AACB8854



A5TD1



A5NEWGEN1



AAPS1008



AACB8855



A5ME8806

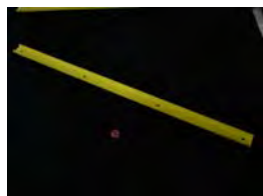

A5ME8807



A5ME8802

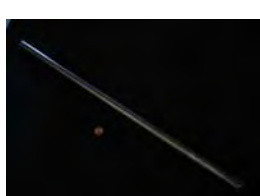

A5ME8800

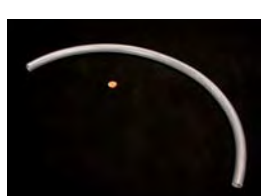

A5TU4400



A5ME8816



A5ME8814



A5PL9097



A5ME8812



AACP8901



AADO8906



AADO8908



AADO8909

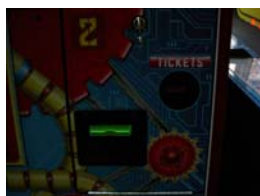

AADO8907



AADO8905



A5CO4400



A5CB1499



A5BURU075



AACO1000



AASO4010



A5LK2000



A5LK5001



A5FI9010



A5SW200



A5CORD5

PARTS PICTURES



AACBL4A-DOOR



AAACE1715



AAACE8811



AAACE8852



AAACE8854



AAACE8856



AAACE8861



AAACE8868



A5OU1000



AAACE8926



AAACE8905



AAACE8906



AAACE8907



AAACE8908



AAACE8909



AAACE8900



AAACE8901



AAACE8902



AAACE8903



AAACE8904



AAACE8910



AAACE8911



AAACE8912



AAACE8913



AAACE8914



AAACE8915



AAACE8916



AAACE8917



AAACE8918



AAACE8919

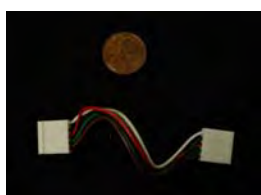

AAACE8920



AAACE8921



AAACE8922



AAPB2700

DECAL PLACEMENT



DECAL DIAGRAM

A5DE8815-1
Marquee Side Left

A5DE8805-1
Cabinet Side Top Left

A5DE8807-1
Cabinet Side Middle Left

A5DE8803-1
Wheel Side Left

A5DE8911
Cabinet Side Bottom Left

FRONT CABINET DECALS:

A5DE8904
Cabinet Front Main

A5DE8905
Coin Door Decal

A5DE8906
Ticket Door Left

A5DE8907
Ticket Door Right

A5DE8908
Mech Door Left

A5DE8909
Mech Door Right



MARQUEE DECALS:

A5DE8912
Marquee Jackpot Decal

A5DE8913
Marquee Jackpot Value Decal

A5DE8914
Marquee Back Lit Logo

A5DE8817-1
Marquee Gear 1 (X2)

A5DE8900 REV A
Marquee Gear 2 Left

A5DE8919
Marquee Gear 2 Right

A5DE8801-1
Pointer (X2)

A5DE8901
Wheel Front (X2)

A5DE8903
Control Panel

(not visible on picture)

A5DE8814-1
Marquee Side Right

A5DE8804-1
Cabinet Side Top Right

A5DE8806-1
Cabinet Side Middle Right

A5DE8802-1
Wheel Side Right

A5DE8910
Cabinet Side Bottom Right

A5DE8915
Option Menu

A5DE8902
Wheel Seam (X2)

MAINBOARD PINOUT

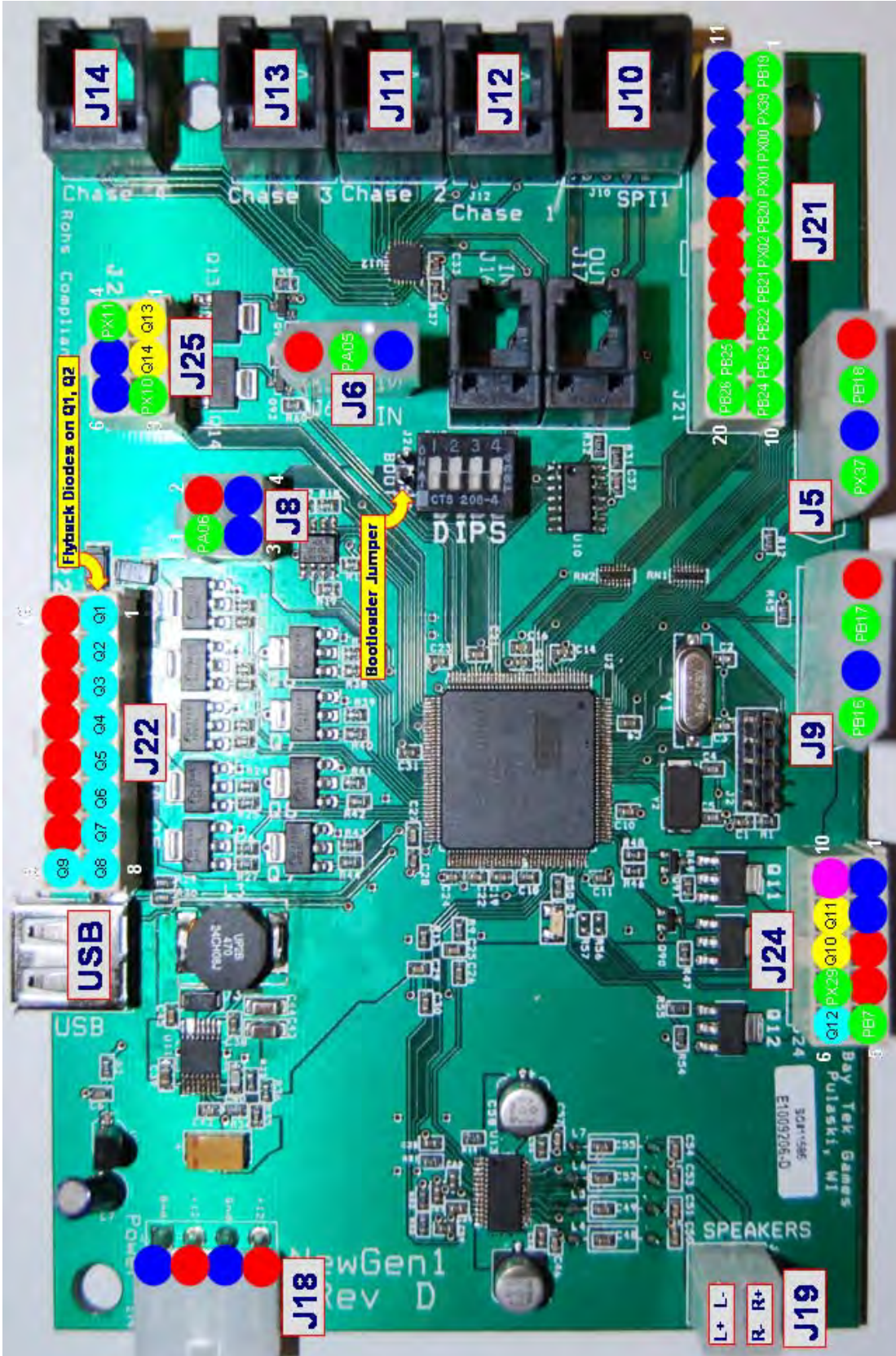

SPI Out - Display - (J10) Chase Lights (J11,J12,J13,J14)

- Ground
 - +12V
 - Low Side Driver
 - High Side Driver
 - +3.3V TTL Logic
 - +3.3V
-
- Pin 1 & Pin 3 - +12V
 - Pin 2 - SCLK_BUS2
 - Pin 4 - SMOSI_BUS2
 - Pin 5 & Pin 7 - Ground
 - Pin 6 - SCS2_BUS2
 - Pin 8 - SMISO_BUS2
-
- Chase Lights (J11,J12,J13,J14)
 - Pin 1 - Chase Output
 - Pin 2 - Chase Output
 - Pin 3 - +12V
 - Pin 4 - Chase Output
 - Pin 5 - Chase Output
 - Pin 6 - +12V

MAINBOARD PINOUT GUIDE

Low Side Driver
High Side Driver
TTL Input/Output
LED Constant Current Drive
12 Volts
Ground

Pin Type	Purpose	Ref	Pin #
LOWSIDE #1, w diode	Solenoid Game #1	J22	1
LOWSIDE #2, w diode	Solenoid Game #2	J22	2
LOWSIDE #3	RED RGB Game #1	J22	3
LOWSIDE #4	BLUE RGB Game #1	J22	4
LOWSIDE #5	GREEN RGB Game #1	J22	5
LOWSIDE #6	RED RGB Game #2	J22	6
LOWSIDE #7	BLUE RGB Game #2	J22	7
LOWSIDE #8	Mechanical Counter (games)	J22	8
LOWSIDE #9	Mechanical Counter (tickets)	J22	9
+12 Volts		J22	11
+12 Volts		J22	12
+12 Volts		J22	13
+12 Volts		J22	14
+12 Volts		J22	15
+12 Volts		J22	16
+12 Volts		J22	17
+12 Volts		J22	18
+12 Volts		J22	19
+12 Volts		J22	20

Pin Type	Purpose	Ref	Pin #
Ground		J24	1
Ground		J24	2
+12 Volts		J24	3
+12 Volts		J24	4
PB7		J24	5
LOWSIDE #12	GREEN RGB Game #2	J24	6
PX29		J24	7
HIGHSIDE #10	Ambient White Lights Game #1	J24	8
HIGHSIDE #11	Ambient White Lights Game #2	J24	9
3.3V		J24	10

PX37	Ticket Notch Game #1	J5	1
Ground	Ground for Ticket Dispensor	J5	2
PB18	Ticket Motor Game #1	J5	3
+12 Volts	Power for Ticket Dispensor	J5	4

PB16	Ticket Notch Game #2	J9	1
Ground	Ground for Ticket Dispensor	J9	2
PB17	Ticket Motor Game #2	J9	3
+12 Volts	Power for Ticket Dispensor	J9	4

PA06	Coin Input GAME #2	J8	1
+12 Volts		J8	2
Ground		J8	3
Ground		J8	4

HIGHSIDE #13		J25	1
HIGHSIDE #14		J25	2
PX10	Low Ticket Input GAME #1	J25	3
PX11	Low Ticket Input GAME #2	J25	4
Ground		J25	5
Ground		J25	6

+12 Volts	Coin Door Power	J6	1
PA05	Coin Input GAME #1	J6	2
Ground	Coin Ground	J6	3

MAINBOARD PINOUT GUIDE

PB19	Service Button #1	J21	1	Driver 1	J12	1
PX39		J21	2	Driver 2	J12	2
PX00	Service Button #2	J21	3	+12 Volts	J12	3
PX01	Wheel Sensor Encoder #2 GAME #2	J21	4	Driver 3	J12	4
PB20	Wheel Sensor Encoder #1 GAME #2	J21	5	Driver 4	J12	5
PX02	Wheel Sensor HOME Input GAME #2	J21	6	+12 Volts	J12	6
PB21	Wheel Sensor Encoder #2 GAME #1	J21	7	Driver 5	J11	1
PB22	Wheel Sensor Encoder #1 GAME #1	J21	8	Driver 6	J11	2
PB23	Wheel Sensor HOME Input GAME #1	J21	9	+12 Volts	J11	3
PB24		J21	10	Driver 7	J11	4
Ground		J21	11	Driver 8	J11	5
Ground		J21	12	+12 Volts	J11	6
Ground		J21	13	Driver 9	J13	1
Ground		J21	14	Driver 10	J13	2
+12 Volts		J21	15	Driver 11	J13	3
+12 Volts		J21	16	+12 Volts	J13	4
+12 Volts		J21	17	Driver 12	J13	5
+12 Volts		J21	18	+12 Volts	J13	6
PB25	DBA Input Game #1	J21	19	Driver 13	J14	1
PB26	DBA Input Game #2	J21	20	Driver 14	J14	2
				+12 Volts	J14	3
				Driver 15	J14	4
				Driver 16	J14	5
				+12 Volts	J14	6

TECHNICAL SUPPORT

Excellent customer service is very important to Bay Tek Games! We know that keeping your games in great operating condition is important to your business. When you need us, we are here to help.

You can call us for free technical assistance, and you can count on us to have parts on-hand to support your game. When you do need us, it's important that you know what to expect. We offer options that fit your needs.

Electronics / Circuit Boards - Repair Options

Repair & Return – If you have Circuit Board issues with your Bay Tek game, you can send the board to us and we'll repair it right away. Most items sent to us are repaired and returned to you within two days. This option is your best value as we offer this fast turn-around service at the most reasonable price.

Advance Replacement – If you have Circuit Board issues with your Bay Tek game, but you don't have time to send in your board in for repair, give us a call and ask for an Advance Replacement. We'll send you a replacement board that same day (pending availability). When you get your new board, just repackage the defective board in the same box and send it back to us. We make it easy by including a UPS Return Shipping label for you to put on the box (not available for international shipments). This is your best option when you need to get you game up and running as quickly as possible!

Spare Parts – Take matters into your own hands and purchase new spare Circuit Boards for your Bay Tek games. Many of our games share the same main-board electronics. This means you can buy one set of spare electronics to support many of your Bay Tek games. Spare boards allow you to get your game up and running the quickest and provide you a valuable troubleshooting option. Call our technicians to get recommendations for what you should keep on hand for spare parts!

Technical Support:

"You" are the best tool for troubleshooting! Your abilities to understand the game and your skills to repair the game are invaluable to us! If you need help, you know you can call us. It's not easy to diagnose a game remotely by phone, but our technicians do a great job. They'll need your help to perform some troubleshooting steps and convey to them exactly what's happening with your game.

Returns, Credits, & Fees:

NOTICE! ALL ITEMS being sent to Bay Tek Games for repair or return, etc. require prior Return Authorization! Bay Tek Games will provide a Product Return Form with an authorizing Ticket Number for each item to be returned. Please be certain to include this document with all shipments!

Late Fees and Non-Return Fees - Advance Replacement and Warranty Replacement items require the defective items to be returned by Bay Tek games promptly to avoid Late Fees. We would expect items to be returned with 10 working days. Late fees are invoiced monthly. Late fees are non-refundable under any circumstance! Any item not returned within 90 days will be invoiced in full as a replacement part!

Bench Fees - Bench fees will apply for each electronic item returned to Bay Tek Games (this includes unused Advance Replacement items). This charge covers our cost to inspect, evaluate and retest each item. Please note that returned items that do not pass our tests will be charged accordingly as replacement items or advance replacements.

Restocking Fees - Unused items returned for credit will be credited minus a restocking fee. Items must be returned within 30 days of purchase in order to qualify for any credit amount. No shipping charges will be credited.



WARRANTY



Bay Tek Games warrants to the original purchaser that all game components will be free of defects in workmanship and materials for a period of 6 months from the date of purchase. If you fill out the registration card in the cashbox of the game, Bay Tek will add another 3 months to your warranty, free of charge.

Bay Tek Games will, without charge, repair or replace defective component parts upon notification to the parts/service department while the game is under warranty.

Warranty replacement parts will be shipped immediately, via ground service, along with a Product Return Form for the return of defective parts.

Defective parts must be shipped back to Bay Tek Games unless otherwise instructed. Items not returned to Bay Tek Games will be invoiced as replacement parts.

This warranty does not apply in the event of any misuse or abuse to the product, or as a result of any unauthorized repairs or alterations. The warranty does not apply if any serial number decal is altered, defaced, or removed from its original position.

	ATTENTION	
In order to maintain the safety & other compliance certifications of the game, ONLY approved parts may be used. For approved parts, refer to the parts list in this manual.		

Should you need your game serviced, determine the serial number from the decal placed on the front of this manual, or locate it on the back of the game. Then contact our Service Department at: 920.822.3951 or e-mail: service@baytekgames.com

NON-WARRANTY

Options and estimated charges will be provided to you for your approval. Please remember that any items being sent to Bay Tek Games must include prior return authorization from our Parts & Service Department. This approval will include a Product Return Form which is required to be included with any incoming shipments. Repaired parts will be shipped back using the same method in which they were received. Repairs are warranted for 30 days from the date of return shipment.

CERTIFICATE OF CONFORMITY



Declaration of Conformity

Manufacturer Identification	Equipment Identification
Bay Tek Games, Inc. 1077 East Glenbrook Drive Pulaski, WI 54162 U.S.A. http://www.baytekgames.com	Crank It! Revolution Model: AAGM-CIR-220V AAGM-CIR-220V-CEC Type: Redemption Game

Council Directive 2004/108/EC	Electromagnetic Compatibility
Emissions Standard: EN 55014-1: 2006 + A1:2009 + A2:2011 Terminal Disturbance Voltage 150kHz - 30MHz Discontinuous Power 30MHz - 300MHz	Immunity Standards: EN 55014-2: 1997 + A1:2001 + A2:2008 ESD IEC61000-4-2:2008-12 Radiated Immunity IEC61000-4-3:2006-02 EFT IEC61000-4-4:2004-07 + A1:2010 Surge IEC61000-4-5:2005-11 Conducted Immunity IEC61000-4-6:2008-10 Power Dips and Interrupts IEC61000-4-11:2004-03
Emissions Standards: EN 61000-3-2:2006 + A1:2009 + A2:2009 Current Harmonics EN 61000-3-3:2008 Voltage Flicker	

Council Directive 2006/95/EC	Low Voltage
Standards: Household and similar electrical appliances - Safety - Part 1: General requirements, IEC 60335-1:2001 (4th Edition) (incl. Corrigendum 1:2002) +A1:2004 +A2:2006 (incl. Corrigendum 1:2006), and Part 2: Particular requirements for amusement machines and personal service machines, IEC 60335-2-82:2002 (2nd edition) +A1:2008 With differences according to EN 62233:2008	

I hereby declare, on behalf of the manufacturer above, that the equipment listed meets the requirements of all applicable Council Directives for CE Marking. Conformance was demonstrated by meeting the requirements of the referenced harmonized Standards.

Name	Title	Signature	Date
Gaetan Philippon	President	<i>Gaetan J. Philippon</i>	8-31-2012
Email: gphilippon@baytekgames.com		Phone: 920-822-3951	

Document Number: 08292012



passion in ★ fun out