

# SERVICE MANUAL



PLACE SERIAL NUMBER LABEL HERE

# FACTORY CONTACT INFORMATION



BAY TEK ENTERTAINMENT  
Pulaski Industrial Park  
1077 East Glenbrook Drive  
Pulaski, WI 54162 USA

SIGN UP TO RECEIVE OUR E-MAILS!

Stay up to date on the latest game information, new products launches, early notification of parts specials, updates of retro fit parts, software upgrades, best practices and more!

Visit [baytekent.com](http://baytekent.com) and enter your email to sign up!

You can also register your new game at [baytekent.com/register](http://baytekent.com/register)

## SALES

Phone: (920) 822-3951

Fax: (920) 822-8936

Email: [baytek.sales@thevillage.bz](mailto:baytek.sales@thevillage.bz)

## PARTS

Phone: (920) 822-3951 Ext 1101

Email: [baytek.parts@thevillage.bz](mailto:baytek.parts@thevillage.bz)

## SERVICE

Phone: (920) 822-3951 Ext 1102

Email: [baytek.service@thevillage.bz](mailto:baytek.service@thevillage.bz)

**Open Monday - Friday  
8 AM - 5PM C.S.T.**

All games are proudly manufactured at our factory in Pulaski, Wisconsin, USA

# TABLE OF CONTENTS

|                                       |         |
|---------------------------------------|---------|
| FACTORY CONTACT INFORMATION .....     | 2       |
| TABLE OF CONTENTS.....                | 3       |
| WELCOME TO Rock The Rim .....         | 4       |
| SAFETY PRECAUTIONS .....              | 4       |
| GAME SPECIFICATIONS .....             | 5       |
| GAME SET UP .....                     | 6 - 11  |
| CARD SWIPE INSTALLATION .....         | 12      |
| HOW TO PLAY .....                     | 13      |
| MAIN MENU FUNCTIONS .....             | 14 - 23 |
| CIRCUIT BOARD LAYOUT .....            | 39      |
| TROUBLESHOOTING GUIDE .....           | 24 - 28 |
| CIRCUIT BOARD LAYOUT .....            | 29 - 30 |
| WIRING DIAGRAMS .....                 | 31 - 37 |
| MB13 MOTHERBOARD DIFFERENCES .....    | 38      |
| SCORING ISSUES .....                  | 39      |
| BALL GATE NOT OPERATING PROPERLY..... | 40      |
| POWER SUPPLY DIAGNOSTICS .....        | 41      |
| BILL ACCEPTOR DIAGNOSTICS .....       | 42      |
| AVAILABLE BLANKING PLATES .....       | 42      |
| HOW TO ADJUST THE BALL GATE .....     | 43      |
| HOW TO REPLACE SCORE SENSOR .....     | 44      |
| HOW TO CHANGE SOFTWARE ON MB12 .....  | 45      |
| HOW TO CHANGE SOFTWARE ON MB13 .....  | 46      |
| HOW TO REPLACE MONITOR .....          | 47 - 50 |
| I/O BOARD DIPSWITCH SETTINGS .....    | 51      |
| I/O AUX BOARD PINOUT .....            | 51      |
| BALL GATE EXPLODED VIEW .....         | 52      |
| DECAL DIAGRAM .....                   | 53      |
| PARTS PICTURES .....                  | 54 - 56 |
| PARTS LIST .....                      | 57 - 58 |
| MAINTENANCE LOG .....                 | 59      |
| TECHNICAL SUPPORT .....               | 60      |
| WARRANTY .....                        | 60      |
| MARQUEE SIGN OPTION .....             | 61 - 66 |
| LINKING KIT OPTION .....              | 67 - 69 |

# WELCOME TO ROCK THE RIM

## Congratulations on your purchase!

Please take a moment to read through this manual and be sure to contact us if you have any questions, or would like more information.

Thank you for your purchase! Your business is important to us and we hope you enjoy this game as much as we do!

*Your Friends at Bay Tek Entertainment*















Please inspect the game for any damaged, loose, or missing parts.

If damage is found, please contact your freight carrier first.

Then, contact Bay Tek Entertainments' Service Department at  
(920) 822-3951 Ext. 1102

Or email us at [baytek.service@thevillage.bz](mailto:baytek.service@thevillage.bz) for further assistance.

## SAFETY PRECAUTIONS

|  |
|--|
|  <b>NOTICE</b>   |
| Modifications to the mechanical, electrical and structural components of this game may void its compliance certifications.   |
| This appliance is suitable for INDOOR, DRY locations only.   |
|  <b>DANGER</b>   |
| DO NOT perform repairs or maintenance on this game with the power ON.<br>Unplug the unit from the wall outlet or shut off the power strip located inside the cabinet.  |
|  <b>WARNING</b>    |
| Use of flammable substances can cause sever burns or serious injury.<br>Always use NON-FLAMMABLE solvents for cleaning. DO NOT use gasoline kerosene or thinners.  |
|  <b>CAUTION</b>    |
| Lifting heavy objects can cause back, neck or other injuries. Be sure adequate lifting and moving devices are available when unloading, unpacking and moving this game.  |
|  <b>ATTENTION</b>    |
| Be sure the electrical power matches the game requirements. See the serial number located on the back of the game cabinet. Always plug into a grounded circuit. If the supply cord is damaged, it must be replaced by an approved cord or assembly provided by the manufacturer.<br><b>A shielded power cable must be used for the game to retain EU/EMC compliance.</b> |
|  <b>IN CASE OF EMERGENCY</b>   |
| UNPLUG THE POWER CORD.<br>The power cord must be accessible at all times in case of an emergency.  |
|  <b>WARNING</b>    |
| This unit is capable of producing sound levels hazardous to human hearing.<br>Consult local sound regulations and adjust volume accordingly.   |

# GAME SPECIFICATIONS

## WEIGHT

|             |          |        |
|-------------|----------|--------|
| NET WEIGHT  | 700 lbs. | 318 kg |
| SHIP WEIGHT | 885 lbs. | 402 kg |

## GAME DIMENSIONS

|        |             |        |
|--------|-------------|--------|
| WIDTH  | 34.5 inches | 88 cm  |
| DEPTH  | 10 feet     | 305 cm |
| HEIGHT | 9 feet      | 274 cm |

## OPERATING TEMPERATURE

|            |              |
|------------|--------------|
| FAHRENHEIT | 45 - 80 F    |
| CELSIUS    | 7.2 - 26.7 C |

## SHIPPING DIMENSIONS

|            |                                       |
|------------|---------------------------------------|
| PALLET # 1 | 60"L x 40"W x 81"H , 375 lbs.         |
| PALLET # 2 | 96"L x 40"W x 87" H 510 bs. class 250 |
| SIGN       | 72"L x 45"W x 20" H , 157 lbs.        |

## POWER REQUIREMENTS

|                       |                |                |
|-----------------------|----------------|----------------|
| INPUT VOLTAGE RANGE   | 100 to 120 VAC | 220 to 240 VAC |
| INPUT FREQUENCY RANGE | 60 Hz          | 50/60 Hz       |

## MAX OPERATING CURRENT

3.2 Amps @ 115 VAC / 2 Amps @ 230 VAC

Note: Game height will be 141.5 inches tall with the marquee.

Shipping information for the marquee:  
Pallet is 72"L x 45"W x 20" H , 157 lbs.

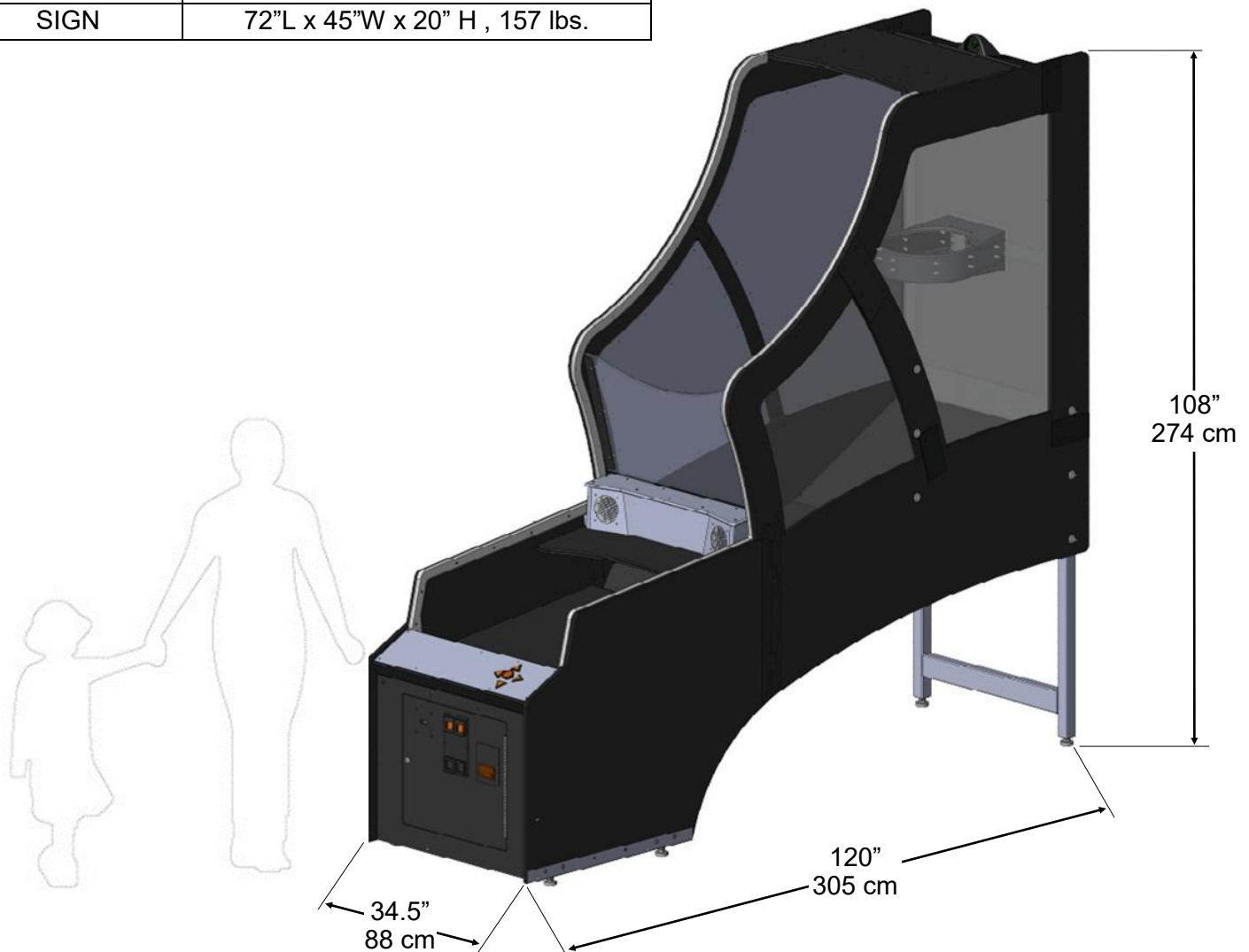

# ROCK THE RIM GAME SETUP

The game will arrive on 2 pallets, the optional marquee will arrive on its own pallet.  
Please inspect the pallets for shipping damage and report immediately to the freight company if any damage found.

## Tools Needed:

1 step ladder (6 foot)  
3 people  
T-30 Torx bit

9/16" Wrench  
7/16" Wren

5/32" Allen wrench.  
# 2 Square head screwdriver bit

## Important:

Portions of this game are heavy, bulky and large. Assembly requires 2 people to lift heavy components, and ladders that are tall and strong enough to position components to the top of the game.

Unbox the small front console pallet first.

- Remove the cardboard surround, and remove the plastic bag.
- Remove the bag of balls and the black plastic cover and set aside for later use.
- Remove the small bag of keys from the top of the front console.
- Remove the "Lag Points Inside" decal and discard.
- Open the front door and cash box.



- Remove the 2 screws holding the front console to the pallet using a T-30 Torx bit. The screws can be discarded.



# ROCK THE RIM GAME SETUP

Unlock the coin box and remove:

- Game Manual
- Power Cord
- Hardware Kit
- Small bag with pin and clip

Remove the front console from the pallet.



Unbox the large pallet:

Remove the cardboard surrounding the rear cabinet, remove the plastic shrink wrap, and cut the 2 banding straps and discard.

Remove the 2 pool noodles, and 4 V cardboard protectors and discard.



The rear legs are swung up inside the cabinet for shipping.

The metal legs can now be swung down, removed and repositioned.

- Swing the rear legs down.
- Remove the two bolts (one from each side) using a 9/16" wrench.  
Save these bolts, washers, and lock nuts for later.

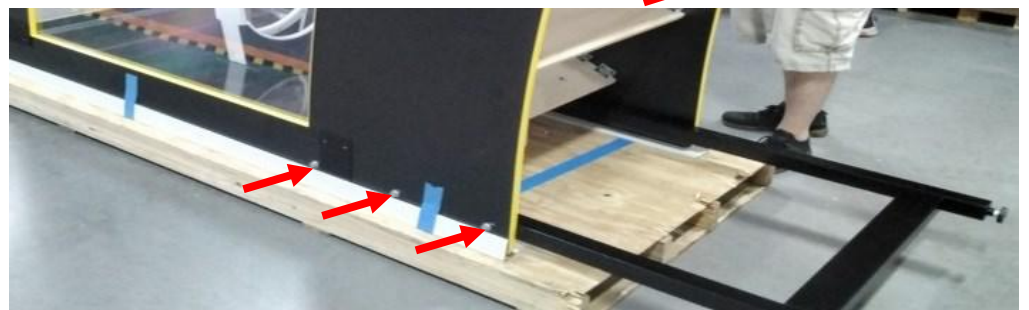

Re-position the rear legs so that all 3 bolts can be inserted into each side as shown.

Remove 4 of each of the following parts from the hardware kit that was inside the coin box on the front section of the game.

Using the 2 sets of bolts removed earlier, install all 6 sets of bolts, washers, and lock nuts using a 9/16" wrench.



A5BOHH090



A5WALO010



A5WAFL085

# ROCK THE RIM GAME SETUP

Now that the rear legs are secure on the rear cabinet, it can be removed from the pallet.

Using 3 people, lift the back of the cabinet up onto its legs.

Position the rear cabinet in position about 2 feet away from the wall near the game's final location.

Note: Do not slide the metal plates across the floor. They will support the weight of the game, but do not bend the metal plates.

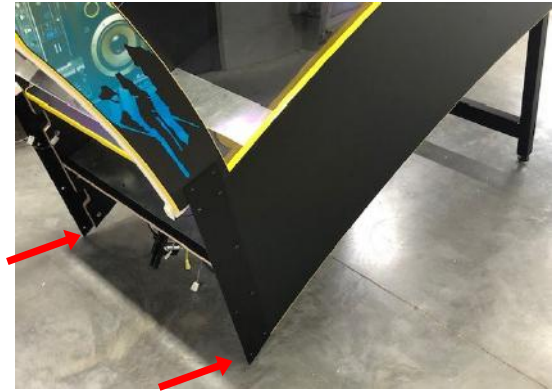

Position the front console cabinet into position close to rear cabinet.

The rear portion of the game can now be lifted by 2 people, while the 3rd person slides the front console cabinet into the rear cabinet.

There are interlocking tabs that will mesh and lock the 2 cabinets together. Once they are locked together, the 2 people can release the cabinet and it can be bolted together.



Remove 8 of 1/4x20 by 3/4" bolts from the hardware kit. (Part # A5SCHH007)



A5SCHH007

Install 4 into each side of the metal bracket joining the 2 sections of the game using a 5/32" Allen wrench.

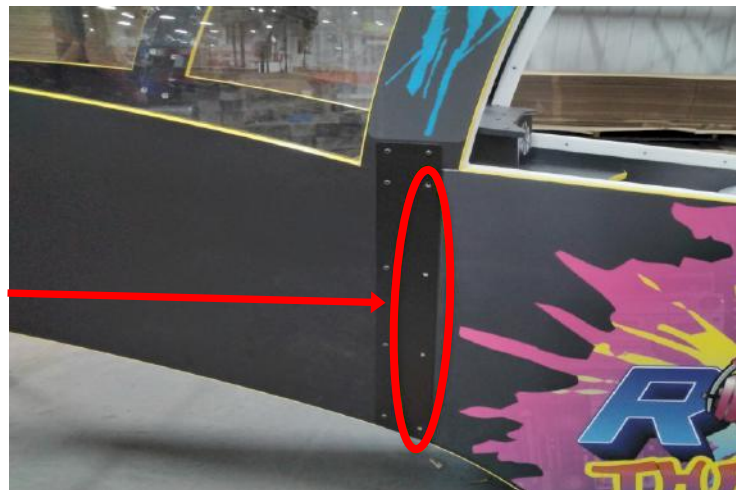

# ROCK THE RIM GAME SETUP

Remove the protective film from the front ball guard.

There are 2 light connections inside the cabinet for the side rail lights.

Located here.



Carefully climb into cabinet and connect these 2 light connection plugs together on both sides of the inside of the cabinet.



Crawl under the cabinet and snip plastic wire ties holding cables carefully to avoid cutting wires.

Connect wires on the right side:

One front AC Power plug to the rear AC power plug

The other front AC Power plug to the other rear AC power plug



Connect wires on the left side:

CE27525 to CE27530

CE27502 to CE27501

CE27505 to CE27507

CE27509 to CE27511

USB cable to USB cable

HDMI cable to HDMI cable

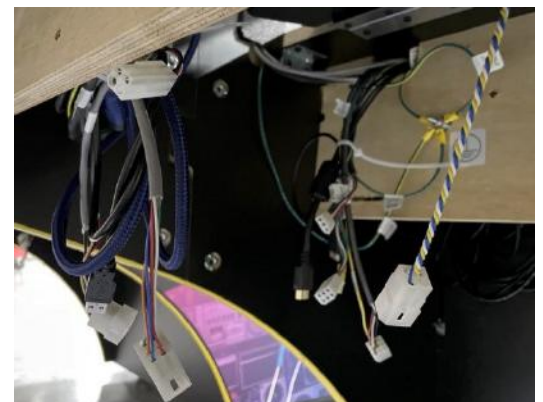

# ROCK THE RIM GAME SETUP

Remove the small bag with pin and clip from the coin box.

Containing:

1 pin part # A5PICV032

1 spacer part # A5SENY170

1 clip part # A5CL3401



These parts will be used to connect the ball gate to the control arm under the cabinet.

Crawl under cabinet and install components into the ball gate as shown:

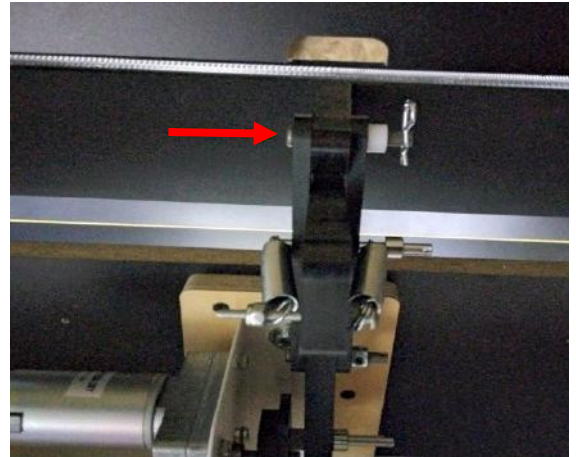

Remove the power cord from the coin box and plug into the rear of the machine.



The game can now be plugged into the wall.

Open the front door, the power switch on the power strip is cleverly hidden here.

Turn on game and allow to boot up.

Unbag the 6 balls and toss all 6 up into the cabinet.

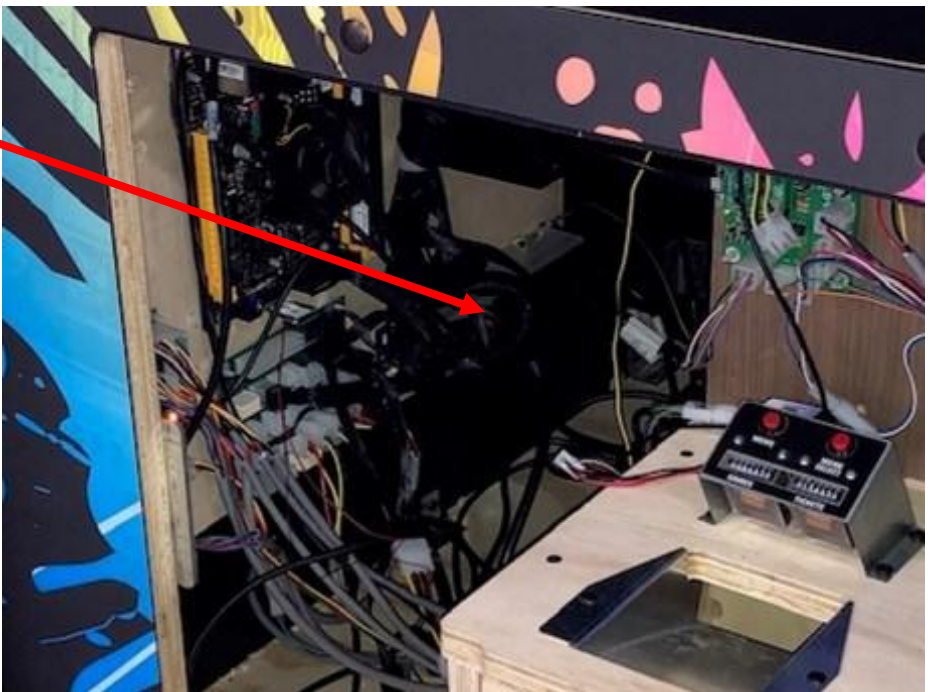

# ROCK THE RIM GAME SETUP

Verify the ball gate opens and closes cleanly and is set to the correct height to stop balls:

Press the menu button to enter the main menu.

Scroll to “Diagnostic”, press the menu select button.

Press the menu select button on “Open Gate” to open the ball gate.

Verify that the balls roll smoothly to the player.

Press the menu select button on “Close Gate” to close the ball gate.

Verify that the balls are being blocked by the ball gate.

If any adjustments need to be made for the ball gate height, loosen the 2 bolts holding the assembly to the wood using a 7/16” wrench.

Re-position the assembly in the appropriate direction and re-tighten the bolts.

Test again using the menu buttons in the diagnostic menu.

When the ball gate height is correct, the black plastic cover can be attached to the bottom of the game.

This will protect the wires and motor from curious fingers.

Locate the thin black plastic panel, and 4 of part # A5SCPH030 from the spare parts kit.



A5SCFH030



Slide the thin black plastic panel into position under the cabinet, sliding the notches into the wood.



Secure the panel using the 4 screws using a # 2 square bit.

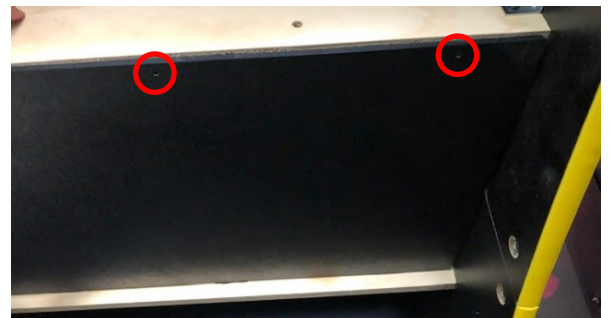

The game is now ready to play! Enter the menu to verify your location specific settings, and enjoy!



This unit is capable of producing sound levels hazardous to human hearing. Consult local sound regulations and adjust volume accordingly.

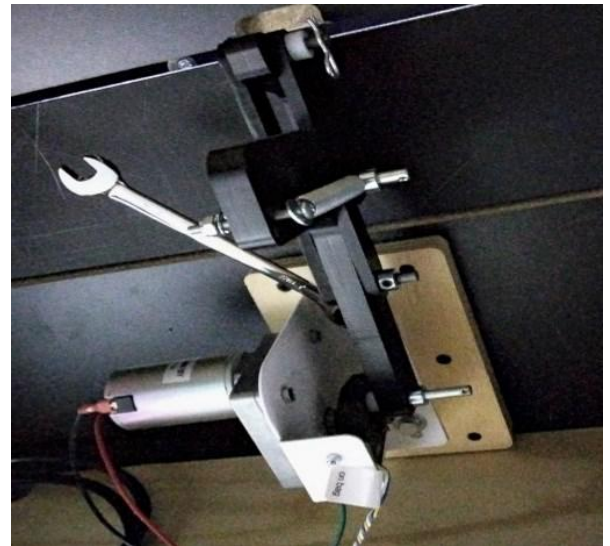
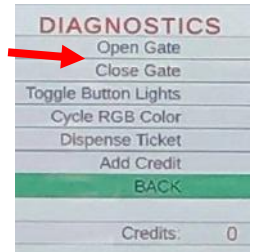
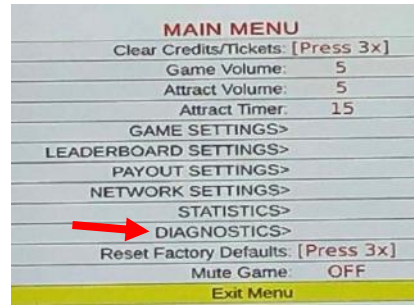

# CARD SWIPE SYSTEM INSTALLATION

The Rock The Rim game is pre-wired with a UCL (Universal Card Link) connector to accept Card Swipe systems from many different manufacturers. Please follow these instructions to make full use of this capability.

## Option #1:

Card swipe systems may come with a standard 9 pin Molex connector. This is the UCL connector. Simply plug this connector into your card swipe reader.

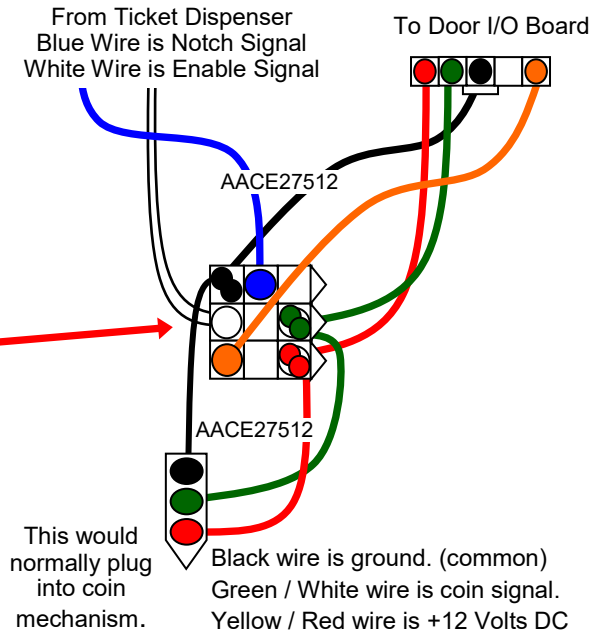

## Option #2:

If your card swipe systems does not have a standard 9 pin Molex connector, then you will have to splice wires into the AACE27512 harness.

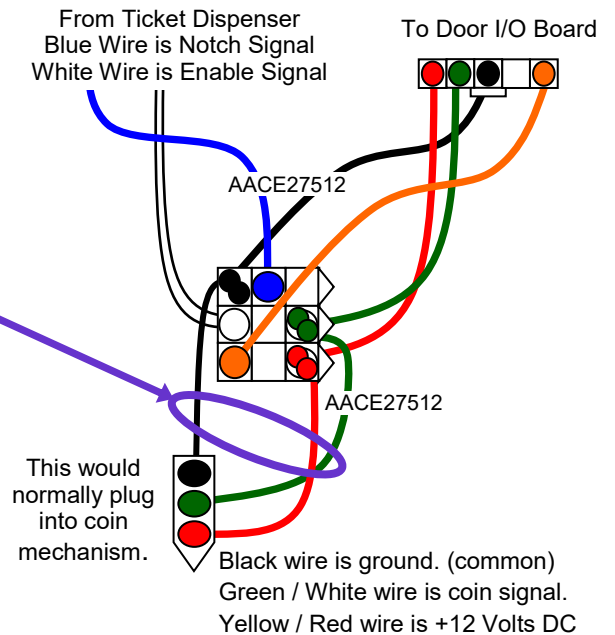

## Notes:

1.) Many card swipe systems have a voltage threshold that can be adjusted in the card swipe menu. Please set this "Game Drive Threshold" to 2 Volts.

## Menu Changes

Enter menu, Go to "Payout Settings" Menu

Change "Credits" to Swipe or Tap

Change "Redemption Type" to Tickets, Points, or Coupons

# HOW TO PLAY

Insert credit and choose one of three different game options:

- 1.) Leaderboard Challenge: Picture and name entry for high scores.
- 2.) Horse: Shoot baskets to win awards, don't spell HORSE.
- 3.) Three Point Shootout: How many baskets can you score in the allotted time?

A camera above the game will take photos of the player.

A motor will turn and release the balls to the player.

After the game is over, the motor will turn and close the ball gate.



High scores will show on the monitor, with options to link to the web to show high scores worldwide.

Link up to 8 games together to play head to head.  
Collect your tickets and enjoy!

# MAIN MENU FUNCTIONS

The Menu and Menu Select buttons are located inside the front door.



Hold the MENU button down for 1 second to open the main menu on the display.

Press MENU to scroll through the options, and MENU SELECT to change the settings.

Default settings are highlighted in yellow below.

| MAIN MENU               |            |
|-------------------------|------------|
| Clear Credits/Tickets:  | [Press 3x] |
| Game Volume:            | 5          |
| Attract Volume:         | 5          |
| Attract Timer:          | 15         |
| GAME SETTINGS>          |            |
| LEADERBOARD SETTINGS>   |            |
| PAYOUT SETTINGS>        |            |
| NETWORK SETTINGS>       |            |
| STATISTICS>             |            |
| DIAGNOSTICS>            |            |
| Reset Factory Defaults: | [Press 3x] |
| Mute Game:              | OFF        |
| Exit Menu               |            |

| MAIN MENU               |   |
|-------------------------|---|
| Clear Credits & Tickets | Press the Menu Select button 5 times to clear any accumulated credits and tickets   |
| Game Volume             | Press the Menu Select button to set Game Music Volume.<br>Cycle from 0 (no Game Volume) to 10 <b>Default is 5</b>                                     |
| Attract Volume          | Press the Menu Select button to set Attract Music Volume.<br>Cycle from 0 (no Attract Volume) to 10 <b>Default is 5</b>                               |
| Attract Timer           | Press the Menu Select button to set the Attract Sequence Timing.<br>Cycle from 0 (no Attract Sequence) to <b>15 minutes</b> between Attract Sequences |
| Game Settings           | Press the Menu Select button to enter the Game Settings Menu  |
| Leaderboard Settings    | Press the Menu Select button to enter the Leaderboard Settings Menu   |
| Payout Settings         | Press the Menu Select button to enter the Payout Settings Menu  |
| Network Settings        | Press the Menu Select button to enter the Network Settings Menu   |
| Statistics              | Press the Menu Select button to enter the Statistics Menu   |
| Diagnostics             | Press the Menu Select button to enter the Diagnostics Menu  |
| Reset Factory Defaults  | Press the Menu Select button 3 times to reset all the options to the Factory Defaults   |
| Mute                    | <b>OFF</b> ON<br>Set to "ON" and exit menu to Mute entire game  |
| Exit                    | Press the Menu Select button to exit menu   |

Software version is shown on the display as you enter the menu.

If it shows **Not Found**, then the circuit board is not communicating to motherboard.

**Software Version 1.0.17**  
**Door Version 1.6**  
**HoopAux Version 1.0**  
**Link Kit Version Not Found**

It is normal that the Link Kit Version show "Not Found" - it only shows on the game with the actual link kit inside the cabinet.

# GAME SETTINGS

Scroll through the options by pressing the “MENU” button.

Change selection with the “SELECT” button.

Scroll to “BACK” and press the “SELECT” button to go back to the main menu.

Default settings are highlighted in yellow below.

| GAME SETTINGS MENU                      |               |
|---|---------------|
| Name Entry Timeout:                     | 15s           |
| Leaderboard Challenge Game Length:      | 45s           |
| HORSE Game Length:                      | 45s           |
| HORSE Hay bales enabled:                | OFF           |
| HORSE Carousel Speed:                   | 2s            |
| Leaderboard Challenge Time Bonus:       | 5s            |
| Leaderboard Challenge Points For Bonus: | 20 points     |
| Leaderboard Challenge On Fire Time:     | 2.5           |
| Three Point Shootout Shot Clock         | Medium (2.5s) |
| BACK                                    |               |

## Name Entry Timeout

|   |   |    |    |    |    |    |
|---|---|----|----|----|----|----|
| 0 | 5 | 10 | 15 | 20 | 25 | 30 |
|---|---|----|----|----|----|----|

Sets the amount of time (in seconds) that the player has to enter a name.

## Leaderboard Challenge Game Length

|    |    |    |    |    |    |    |    |    |
|----|----|----|----|----|----|----|----|----|
| 20 | 25 | 30 | 35 | 40 | 45 | 50 | 55 | 60 |
|----|----|----|----|----|----|----|----|----|

Sets the amount of time (in seconds) of the Leaderboard Challenge game.

## Horse Game Length

|    |    |    |    |    |    |    |    |     |     |     |
|----|----|----|----|----|----|----|----|-----|-----|-----|
| 20 | 25 | 30 | 35 | 40 | 45 | 50 | 60 | ... | 115 | 120 |
|----|----|----|----|----|----|----|----|-----|-----|-----|

Sets the amount of time (in seconds) of the Horse game.

## Horse Hay Bales Enabled

|     |    |
|-----|----|
| OFF | ON |
|-----|----|

“OFF” means the game will incorporate little piles of poo poo into the game play video.

“On” means the game will display hale bales instead of the little piles of poo poo.

## Horse Carousel Speed

|     |      |   |      |     |
|-----|------|---|------|-----|
| 1.5 | 1.75 | 2 | 2.25 | 2.5 |
|-----|------|---|------|-----|

Sets the amount of time (in seconds) that the bonus items cycle during the Horse game.

# GAME SETTINGS

Scroll through the options by pressing the “MENU” button.

Change selection with the “SELECT” button.

Scroll to “BACK” and press the “SELECT” button to go back to the main menu.

Default settings are highlighted in yellow below.

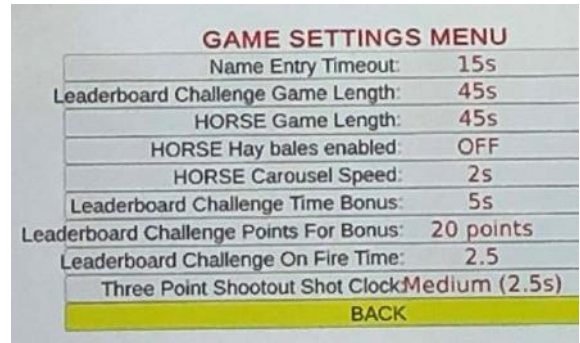

## Leaderboard Challenge Time Bonus

|   |   |   |   |   |    |
|---|---|---|---|---|----|
| 5 | 6 | 7 | 8 | 9 | 10 |
|---|---|---|---|---|----|

Sets the amount of time (in seconds) of the Time Bonus in the Leaderboard Challenge game.

## Leaderboard Challenge Points for Bonus

|    |    |    |    |    |    |    |     |    |    |    |
|----|----|----|----|----|----|----|-----|----|----|----|
| 15 | 16 | 17 | 18 | 19 | 20 | 21 | ... | 28 | 29 | 30 |
|----|----|----|----|----|----|----|-----|----|----|----|

Sets the amount of points needed before the Time Bonus is awarded.

## Leaderboard Challenge On Fire Time

|   |      |     |      |   |
|---|------|-----|------|---|
| 2 | 2.25 | 2.5 | 2.75 | 3 |
|---|------|-----|------|---|

Sets the amount of time (in seconds) between scores that are needed for 5 scores for the “On Fire” feature to be activated.

For the default 2.5 seconds: 5 baskets must be scored with no more than 2.5 seconds between each score. You can miss in between, but that scored ball must sink within 2.5 seconds from the last score.

“On fire” will end if you take longer than 5 seconds to make a basket.

## Three Point Shootout Shot Clock

|             |             |               |
|-------------|-------------|---------------|
| Easy (3.0s) | Hard (2.0s) | Medium (2.5s) |
|-------------|-------------|---------------|

“Sets the amount of time (in seconds) to score each shot in the Three Point Shootout game.

# LEADERBOARD SETTINGS

Scroll through the options by pressing the “MENU” button.

Change selection with the “SELECT” button.

Scroll to “BACK” and press the “SELECT” button to go back to the main menu.

Default settings are highlighted in yellow below.

| LEADERBOARD SETTINGS    |    |
|-------------------------|----|
| Local Daily Entries:    | 10 |
| Local Weekly Entries:   | 10 |
| Local Monthly Entries:  | 10 |
| Global Daily Entries:   | 10 |
| Global Weekly Entries:  | 10 |
| Global Monthly Entries: | 10 |
| Display Player Images:  | ON |
| EDIT ENTRIES>           |    |
| EDIT NAME FILTER>       |    |
| BACK                    |    |

## Local Daily Entries

|    |    |    |    |    |    |    |    |    |
|----|----|----|----|----|----|----|----|----|
| 10 | 15 | 20 | 25 | 30 | 35 | 40 | 45 | 50 |
|----|----|----|----|----|----|----|----|----|

Sets the maximum number of high scores to be displayed on the game’s Daily list.

## Local Weekly Entries

|    |    |    |    |    |    |    |    |    |
|----|----|----|----|----|----|----|----|----|
| 10 | 15 | 20 | 25 | 30 | 35 | 40 | 45 | 50 |
|----|----|----|----|----|----|----|----|----|

Sets the maximum number of high scores to be displayed on the game’s Weekly list.

## Local Monthly Entries

|    |    |    |    |    |    |    |    |    |
|----|----|----|----|----|----|----|----|----|
| 10 | 15 | 20 | 25 | 30 | 35 | 40 | 45 | 50 |
|----|----|----|----|----|----|----|----|----|

Sets the maximum number of high scores to be displayed on the game’s Monthly list.

## Global Daily Entries

|    |    |    |    |    |    |    |    |    |
|----|----|----|----|----|----|----|----|----|
| 10 | 15 | 20 | 25 | 30 | 35 | 40 | 45 | 50 |
|----|----|----|----|----|----|----|----|----|

Sets the maximum number of high scores to be displayed on the game’s Daily list from all games linked to the internet. Online Features must be set to ON in Network Settings Menu.

## Global Weekly Entries

|    |    |    |    |    |    |    |    |    |
|----|----|----|----|----|----|----|----|----|
| 10 | 15 | 20 | 25 | 30 | 35 | 40 | 45 | 50 |
|----|----|----|----|----|----|----|----|----|

Sets the maximum number of high scores to be displayed on the game’s Weekly list from all games linked to the internet. Online Features must be set to ON in Network Settings Menu.

## Global Monthly Entries

|    |    |    |    |    |    |    |    |    |
|----|----|----|----|----|----|----|----|----|
| 10 | 15 | 20 | 25 | 30 | 35 | 40 | 45 | 50 |
|----|----|----|----|----|----|----|----|----|

Sets the maximum number of high scores to be displayed on the game’s Monthly list from all games linked to the internet. Online Features must be set to ON in Network Settings Menu.

## Display Player Images

|    |     |
|----|-----|
| ON | OFF |
|----|-----|

If set to “ON” - the screen will show the player’s picture next to their high score.

# LEADERBOARD SETTINGS

Scroll through the options by pressing the “MENU” button.  
Change selection with the “SELECT” button.

Scroll to “BACK” and press the “SELECT” button to go back to the main menu.



## EDIT ENTRIES

The pictures taken by the game can be deleted if desired.

Press the Menu Select to enter the Leaderboard Entries Menu

Use the “NEXT PAGE” and “PREVIOUS PAGE” to cycle through the blocks of pictures.

Once on the desired page,

**Scroll through the pictures using the arrow buttons on the console.**

Press the center button on the console to select an image.

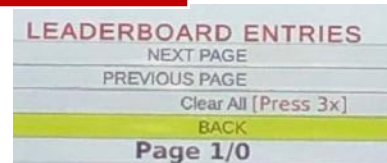

To delete picture, use the arrow buttons to highlight the “Delete” icon, then press the center button to delete.



## EDIT NAME FILTER

Bad words and swears are automatically not allowed to be entered as player names.

More words can be added to this filter manually by the game owner by entering the “Name Filtering Menu”

For example, if you do not want a player to enter “My Gosh” as a name, use the Menu Select to scroll to “ADD” and press the menu button.

A keyboard will show on the screen: Use the control panel arrows and center button to select letters.

MY GOSH

Select the “Enter” button to enter the word into the database.

Note: This will edit out any instances of the entered word.

For Example; If IT was entered, the game will show asterisks for any instance of it. The name BONITA will show as BON\*\*A

To remove a word from this filter and allow it to be used as a name, use the “NEXT PAGE” and “PREVIOUS PAGE” to cycle through the blocks of names.

Once on the desired page,

**Scroll through the pictures using the arrow buttons on the console.**

Press the center button on the console to select remove the name from this bad word list.

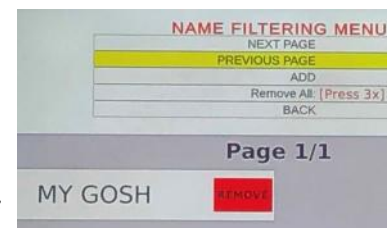
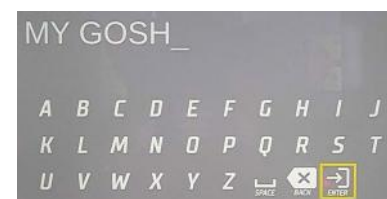

# PAYOUT SETTINGS MENU

Scroll through the options by pressing the “MENU” button.

Change selection with the “SELECT” button.

Scroll to “BACK” and press the “SELECT” button to go back to the main menu.

Default settings are highlighted in yellow below.

|                              |         |
|------------------------------|---------|
| <b>PAYOUT SETTINGS</b>       |         |
| Credits:                     | 1       |
| Redemption type:             | Tickets |
| <b>Leaderboard Challenge</b> |         |
| Tickets:                     | 1       |
| Per Points:                  | 5       |
| <b>HORSE</b>                 |         |
| Tickets:                     | 1       |
| Per Points:                  | 5       |
| <b>Three Point Shootout</b>  |         |
| Tickets:                     | 1       |
| Per Points:                  | 5       |
| Entertainment Only:          | OFF     |
| BACK                         |         |

## Credits

|       |     |   |   |   |   |     |    |    |
|-------|-----|---|---|---|---|-----|----|----|
| SWIPE | TAP | 0 | 1 | 2 | 3 | ... | 19 | 20 |
|-------|-----|---|---|---|---|-----|----|----|

Sets the amount of credit pulses needed to start a game. “SWIPE” will display “Swipe Card to play” on the monitor. “TAP” will display “Tap Card to Play” on the monitor. “0” will be free play.

## Redemption Type

|         |        |         |
|---------|--------|---------|
| Tickets | Points | Coupons |
|---------|--------|---------|

Sets the wording on the screen used to describe the tickets won.

## LEADERBOARD CHALLENGE TICKET PAYOUT SETTINGS

### Tickets

|   |   |   |   |   |   |   |   |   |    |
|---|---|---|---|---|---|---|---|---|----|
| 1 | 2 | 3 | 4 | 5 | 6 | 7 | 8 | 9 | 10 |
|---|---|---|---|---|---|---|---|---|----|

Sets the amount of Tickets won per number of points in the next option

### Per Points

|   |   |   |   |   |   |   |   |   |    |
|---|---|---|---|---|---|---|---|---|----|
| 1 | 2 | 3 | 4 | 5 | 6 | 7 | 8 | 9 | 10 |
|---|---|---|---|---|---|---|---|---|----|

Sets the point interval in which the game will pay the selected number of tickets.

For example: If tickets is set to 6, and Per Points to 3, the game will pay 6 tickets for every 3 points.

# PAYOUT SETTINGS MENU

Scroll through the options by pressing the “MENU” button.

Change selection with the “SELECT” button.

Scroll to “BACK” and press the “SELECT” button to go back to the main menu.

Default settings are highlighted in yellow below.

|                              |         |
|------------------------------|---------|
| <b>PAYOUT SETTINGS</b>       |         |
| Credits:                     | 1       |
| Redemption type:             | Tickets |
| <b>Leaderboard Challenge</b> |         |
| Tickets:                     | 1       |
| Per Points:                  | 5       |
| <b>HORSE</b>                 |         |
| Tickets:                     | 1       |
| Per Points:                  | 5       |
| <b>Three Point Shootout</b>  |         |
| Tickets:                     | 1       |
| Per Points:                  | 5       |
| Entertainment Only:          | OFF     |
| BACK                         |         |

## HORSE GAME TICKET PAYOUT SETTINGS

### Tickets

|   |   |   |   |   |   |   |   |   |    |
|---|---|---|---|---|---|---|---|---|----|
| 1 | 2 | 3 | 4 | 5 | 6 | 7 | 8 | 9 | 10 |
|---|---|---|---|---|---|---|---|---|----|

Sets the amount of Tickets won per number of points in the next option

### Per Points

|   |   |   |   |   |   |   |   |   |    |
|---|---|---|---|---|---|---|---|---|----|
| 1 | 2 | 3 | 4 | 5 | 6 | 7 | 8 | 9 | 10 |
|---|---|---|---|---|---|---|---|---|----|

Sets the point interval in which the game will pay the selected number of tickets.

For example: If tickets is set to 6, and Per Points to 3, the game will pay 6 tickets for every 3 points.

## THREE POINT SHOOTOUT TICKET PAYOUT SETTINGS

### Tickets

|   |   |   |   |   |   |   |   |   |    |
|---|---|---|---|---|---|---|---|---|----|
| 1 | 2 | 3 | 4 | 5 | 6 | 7 | 8 | 9 | 10 |
|---|---|---|---|---|---|---|---|---|----|

Sets the amount of Tickets won per number of points in the next option

### Per Points

|   |   |   |   |   |   |   |   |   |    |
|---|---|---|---|---|---|---|---|---|----|
| 1 | 2 | 3 | 4 | 5 | 6 | 7 | 8 | 9 | 10 |
|---|---|---|---|---|---|---|---|---|----|

Sets the point interval in which the game will pay the selected number of tickets.

For example: If tickets is set to 6, and Per Points to 3, the game will pay 6 tickets for every 3 points.

### Entertainment Only

|     |    |
|-----|----|
| OFF | ON |
|-----|----|

OFF will pay out tickets like a normal redemption game. Set to “ON” to play without paying tickets.

# NETWORK SETTINGS

The Network Settings menu will allow you game to access the internet and load Leaderboard Challenge Game high scores to a database that will show the high scores and pictures on all games set to Online.

| NETWORK SETTINGS     |              |
|----------------------|--------------|
| Online Features:     | OFF          |
| BACK                 |              |
| Machine Mac Address: | F4B52021351D |
| Online Status:       | Offline      |

Instructions:

- 1.) Set "Online Features" to ON
- 2.) Plug a network cable from the Motherboard to the wall.

The "Online Status" should show "Online"

If it still shows "Offline" - reboot the game, check network cable and contact your network administrator.

Note:

When set to "Online" the game will automatically load the default settings for the Leaderboard Challenge Game so that all global players are playing with the same settings:

Game Length = 45 seconds

Time Bonus = 5 seconds

Points for Bonus = 20 points

On Fire Time = 2.5 seconds

# GAME STATISTICS MENU

Scroll through the options by pressing the “MENU” button.

Change selection with the “SELECT” button.

Scroll to “BACK” and press the “SELECT” button to go back to the main menu.

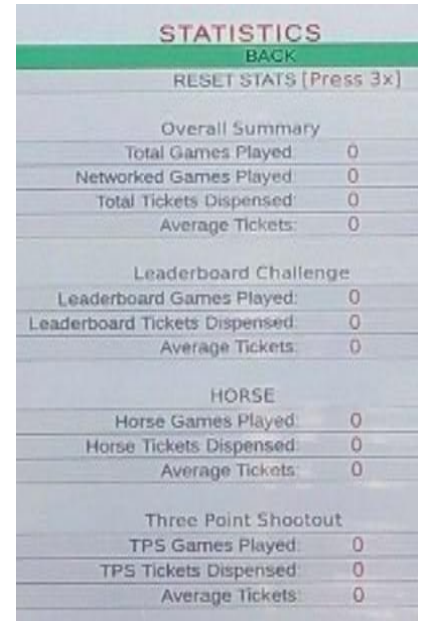

| STATISTICS                     |   |
|--------------------------------|---|
| BACK                           |   |
| RESET STATS (Press 3x)         |   |
| Overall Summary                |   |
| Total Games Played:            | 0 |
| Networked Games Played:        | 0 |
| Total Tickets Dispensed:       | 0 |
| Average Tickets:               | 0 |
| Leaderboard Challenge          |   |
| Leaderboard Games Played:      | 0 |
| Leaderboard Tickets Dispensed: | 0 |
| Average Tickets:               | 0 |
| HORSE                          |   |
| Horse Games Played:            | 0 |
| Horse Tickets Dispensed:       | 0 |
| Average Tickets:               | 0 |
| Three Point Shootout           |   |
| TPS Games Played:              | 0 |
| TPS Tickets Dispensed:         | 0 |
| Average Tickets:               | 0 |

## RESET STATISTICS

Press the “SELECT” button 3 times to reset all statistics.

## Overall Summary

**Total Games Played** - Shows the total number of games played

**Networked Games Played** - Shows the total number of Linked Games Played

**Average Tickets** - Shows the total average number of tickets per game

## Leaderboard Challenge Summary

**Leaderboard Games Played** - Shows the total number of Leaderboard Challenge games played

**Networked Tickets Dispensed** - Shows the total number of tickets on Leaderboard Challenge games

**Average Leaderboard Tickets** - Shows the average number of tickets per Leaderboard Challenge game

## Horse Summary

**Horse Games Played** - Shows the total number of Horse games played

**Horse Tickets Dispensed** - Shows the total number of tickets for all Horse games

**Average Leaderboard Tickets** - Shows the average number of tickets per Horse game

## Three Point Shootout Summary

**3 Point Shootout Games Played** - Shows the total number of Three Point Shootout games played

**3 Point Shootout Tickets Dispensed** - Shows the total number of tickets for 3 Point Shootout games

**Average 3 Point Shootout Tickets** - Shows the average number of tickets per 3 Point Shootout game

# GAME DIAGNOSTIC MENU

Scroll through the options by pressing the “MENU” button.

Change selection with the “SELECT” button.

Scroll to “BACK” and press the “SELECT” button to go back to the main menu.

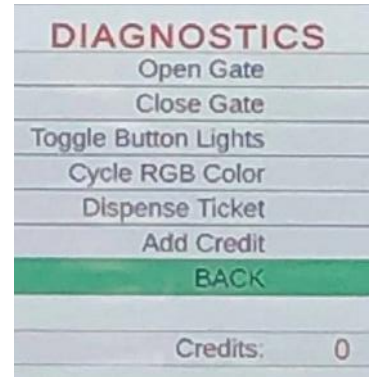

**Open Gate:** Press Menu Select to lower the ball gate.

**Close Gate:** Press Menu Select to raise the ball gate.

**Toggle Button Lights:** Press Menu Select to turn the control panel lights on and off.

**Cycle RGB Color:** Press Menu Select to change the color of the lights on the sides of the game. Colors will cycle through: Red, Green, Blue, Pink, and Yellow.

Note: Game colors are only Yellow, Blue, and Pink

**Dispense Ticket:** Press Menu Select to dispense 1 ticket from the ticket dispenser.

**Add Credit:** Press Menu Select to add a ticket to the game.

**Back:** Press Menu Select to return to the main menu.

**Credits:** This will show credits when the coin switch or card swipe is triggered. This is useful in diagnosing coin up issues.

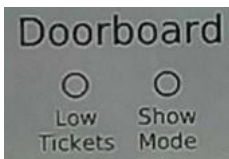

**Door Board:** Shows the low tickets switch and dipswitch setting for the Door Interface board.



## Control Board:

Top Sensor - Will be active when the top sensor in the hoop is blocked.

Bottom Sensor - Will be active when the bottom sensor in the hoop is blocked.

Gate Sensor - Will be active when the sensor in the motor assembly is blocked. - Will activate when the gate is both closed and open. It will not be activated while the motor is moving.



## Control Board:

Up/Down/Left/Right/Center - Will activate when the control panel push buttons are pressed.

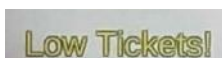

## Low Tickets:

This will show when the game thinks that the low ticket switch is not held down by the stack of tickets.

This can be disabled by turning dipswitch # 5 ON on the Door Interface Board.

# TROUBLESHOOTING GUIDE



## Troubleshooting Strategy

Use common sense and a systematic method of troubleshooting to determine the exact problem, probable cause and remedy. Use the process of elimination to find the faulty component. Always check for the simple and obvious causes first such as unplugged, loose or broken wires and bad sensors, bent, pinched, stuck or jammed components.

### Troubleshooting Chart

| Problem   | Probable Cause  | Remedy   |
|---|---|--|
| <p><b>No power to the game</b><br/><b>No lights on at all</b></p>   | <p>Unplugged.<br/>Circuit breaker tripped.<br/><br/>Line Filter Faulty.<br/>Power strip faulty.<br/><br/>Disconnected, loose or broken wires.</p>                                   | <p>Check wall outlet.<br/>Reset power strip breaker switch or building circuit breaker.<br/>Replace Line Filter (Part # A5FI9010)<br/>Change plug position, replace power strip if a section does not work. Part # A5OU5000<br/>Check rocker switch on power strip.<br/><br/>Refer to wiring diagram. Check connections and reseal cables from line filter to outlet strip. Cables # CE27520 and A5CORD5<br/><b>If the supply cord is damaged, it must be replaced by a special cord or assembly available from the manufacturer or its service agent.</b></p> |
| <p><b>Monitor is on</b><br/><b>But everything else off</b><br/><br/><b>(Power Supply not ON)</b></p>  | <p>Power supply unplugged.<br/>Rocker Switch.<br/><br/>Power supply shutting down because of 12 V overload.<br/>Faulty power supply.<br/>Faulty Power Dist Board</p>                | <p>Insure power supply is plugged into power strip<br/>Make sure rocker switch is set ON. </p> <p>See power supply diagnostics to isolate bad component. A bad motor or 12 volt short would cause this.<br/>See Power Supply Diagnostic below.<br/>Replace Power Distribution Board (AACB5156)</p>   |
| <p><b>Dollar Bill Acceptor not functioning</b><br/>Ensure Bill Acceptor is set to "Always Enable"<br/><b>Important : Only 12 Volt DC DBA is to be installed.</b><br/><br/>Model # AE 2454 U5E<br/>Part # A5AC9101</p> | <p>Check for power to Bill Acceptor.<br/>Dirt or debris in acceptor slot.<br/><br/>Pinched, broken, or disconnected wiring.<br/><br/>Bill acceptor problem.<br/>Part # A5AC9101</p> | <p>Acceptor should cycle stacker at game power up. If not, check cable connections.<br/>Refer to "How to Clean Bill Acceptor" Or clean with bill reader cleaning card. (A5CC9000)<br/>Check wiring from bill acceptor to I/O Aux Board. (AACE27503) Repair or replace wiring harness. Make sure wires are secure in connectors.<br/><br/>Refer to troubleshooting section of dollar bill acceptor manual included with this game or the diagnostics label of the back of the unit.</p>   |
| <p><b>Meters does not work</b><br/>Game meter will click as you choose your game mode.<br/>Ticket meter will click as tickets come out of game and notch is "seen" by dispenser.</p>                                  | <p>Ensure correct number of tickets are being dispensed<br/>Disconnected, loose or broken wires.<br/><br/>Faulty counter.</p>   | <p>Check ticket values in menu. Refer to Tickets not dispensing troubleshooting section.<br/>Refer to wiring diagram. Check connections and reseal cables from meters to I/O Aux Board Cables # AACO1020 and CE27508<br/>Replace counter. AACO1020.</p>  |





# TROUBLESHOOTING GUIDE

| Problem   | Probable Cause  | Remedy  |
|---|---|---|
| <p><b>Game not coining up</b><br/>Enter Diagnostic Mode to see if Credits Increment when coin is inserted.</p>  | <p>Look for communication and power on the I/O Aux Board for that player.</p> <p>Ensure game makes sound when coin switch is triggered.</p> <p>Game set to large amount of credits per game.</p> <p>Coin Input stuck ON</p> | <p>Refer to “I/O Aux Board Issue” diagnostic section.</p>  <p>Check coin switches—both should be wired normally open. If one switch is “closed” the other will not work either. Check wiring to I/O Aux Board. (AACBL4A-DOORA, CE27512)</p> <p>Check Game Setup Menu. Ensure Credits is set to proper value.</p> <p>Ensure only 5 volts on coin switch green and black wires. Replace I/O Aux board if needed. Part # AACB9605-CBL</p>   |
| <p><b>No Sound</b><br/>Motherboard creates sound, the Audio Amplifier boards amplifies it.</p>  | <p>Volume set to mute in menu or game volume/attract volume set to zero.</p> <p>Disconnected, loose or broken wires.</p> <p>Verify 12 Volts DC to Audio Amplifier Boards on CE27519</p> <p>Faulty speaker.</p>              | <p>Enter Main Menu and verify: Game Volume &amp; Attract Volume is not zero. Mute is set to OFF</p> <p>Refer to wiring diagram. Check connections and reseal audio cable from motherboard to speakers. Cables # A5CE2300, A5SP10001, A5CEAU010, CE27519, CE27500, CE27533, AACE8811, and the Subwoofer A5SW0020</p> <p>Unplug audio cable (A5CE2300) from motherboard, plug into MP3 player or phone and see if music is amplified and comes out of speaker.</p> <p style="padding-left: 20px;">If Yes - then motherboard is faulty.</p> <p style="padding-left: 20px;">If No - then cable or amplifier board is faulty</p> <p>Replace speaker. AASP27500's or A5SW0020</p> |
| <p><b>I/O Aux Board Issue</b><br/>Game does not coin up, and has no other functions.</p>  <p style="font-size: small; margin-top: 5px;">Red and Yellow LEDs      Green Power LED</p> | <p>Green power LED should be flashing.</p> <p>Red and Yellow LED's should be on solid, with yellow LED randomly blinking.</p> <p>Faulty I/O Aux Board.</p>  | <p>If it is off, then check 12 &amp; 5 Volts DC coming into board on cable CE27518 from Power Distribution Board.</p> <p>If not on, then it is not communicating with the motherboard. Check A5CBL5900 USB cable. Swap cables with light board.</p> <p>If they are off, check power into board on CE27518 cable. Replace board if needed.</p> <p>Replace if needed. Part # AACB9605-CBL</p>   |
| <p><b>Low Tickets message on monitor</b></p>   | <p>Tickets are empty in ticket tray</p> <p>Faulty cable. Disconnected, loose or broken wires.</p> <p>Faulty low ticket switch.</p> <p>Dipswitch on I/O Aux Board.</p> <p>Faulty I/O Aux Board.</p>                          | <p>Load tickets into tray. Ensure tickets hold down the micro switch wire.</p> <p>Check connectors from low ticket switch to Newgen board. Check for continuity. (AACE27510)</p> <p>Inspect switch and replace if needed. (AASW200)</p> <p>Check dipswitch settings on the I/O Aux board. If the game has a card swipe system, Dipswitch # 5 should be ON.</p> <p>Replace I/O Aux Board. Part # AACB9605-CBL</p>  |

# TROUBLESHOOTING GUIDE

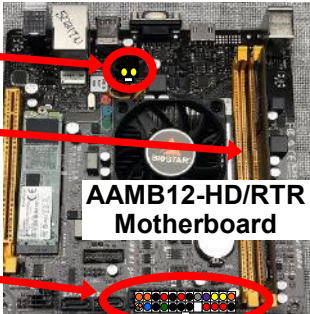
| Problem   | Probable Cause  | Remedy   |
|---|---|--|
| <p><b>Tickets do not dispense or Wrong amount dispensed</b></p> <p>Check for the correct amount of tickets showing on Monitor</p> | <p>Tickets on monitor does <b>not</b> match tickets coming out of game.</p> <p>Opto Sensor on ticket dispenser dirty.<br/>Faulty ticket dispenser.<br/>Notch on tickets cut too shallow.<br/>Faulty cable. Disconnected, loose or broken wires.<br/>Faulty I/O Aux Board.</p> | <p>Blow dust from sensor and clean with isopropyl alcohol.<br/>Replace with working dispenser to isolate the problem. (A5TD1)<br/>Flip tickets and load upside-down to have large cut notch toward opto sensor.<br/>Check connectors from ticket dispensers to I/O Aux board. Check for continuity.(CE27510 and CE27512)<br/>Ensure issue is not with a card swipe system - Replace I/O Aux Board. Part # AACB9605-CBL</p> |
| <p>Tickets on monitor do match tickets coming out of game</p>   | <p>Settings in Menu are incorrect.</p>  | <p>Enter Menu and check certain areas:<br/>Entertainment Only to Off<br/>Tickets Per Game for the 3 game modes.<br/>Door Board Dipswitch Settings:<br/>1/2 Ticket Payout<br/>Fixed tickets</p>   |
| <p><b>Menu Buttons do not work.</b></p> <p>The menu buttons are located in the Left Side Coin Door</p>                            | <p>Swap connectors at the 2 buttons.<br/>Pinched, broken, or disconnected wiring<br/>I/O Aux board faulty.</p>  | <p>Replace button if problem stays with button.(AAPB2700A)<br/>Inspect crimp to ensure good connection.<br/>Check connections from menu buttons to I/O Aux Board.<br/>Check cables (AAPB2700A, AACE27508)<br/>Replace I/O Aux Board if needed. Part # AACB9605-CBL</p>   |
| <p><b>All LED Color Strips are not Working</b></p> <p>Light Board issue</p>   | <p>Ensure Light Board is receiving voltage from Power Distribution Board.<br/>Ensure USB cable has good communication to the motherboard.<br/>Faulty LED</p>  | <p>Refer to wiring diagram. Check connections &amp; reseal cables from Power Distribution Board to Light Board. CE27517<br/>Refer to wiring diagram. Check connections and reseal USB cable from Motherboard to Light Board..<br/>Cable # A5CBL5900<br/>Refer to wiring diagram. All light cables plug into the Light Board.</p>   |
| <p><b>LED Lights in the Hoop are not Working</b></p>  | <p>Loose or bad connection.<br/>1 faulty LED can cause all LED strips to show as faulty.<br/>Test LED's in Diagnostic Menu<br/>Faulty LED</p>   | <p>Refer to wiring diagram. Check multiple connections and reseal cables from Light Board to Hoop. Cables # LD27536, CE27516, CE27507, CE27506<br/>Unplug 2 of the 3 LED light strips to find the 1 faulty LED Light Strip.<br/>Enter menu, scroll to Diagnostic Menu &amp; "Cycle RGB Color"<br/>Replace faulty LED. Part # AALD27536</p>   |
| <p><b>LED Lights in the Left and Right Rail are not Working</b></p>   | <p>Loose or bad connection.<br/>Test LED's in Diagnostic Menu<br/>Faulty LED</p>  | <p>Refer to wiring diagram. Check multiple connections and reseal cables from Light Board to Side Rails.<br/>Cables # LD27537, LD27538, CE27513<br/>Enter menu, scroll to Diagnostic Menu, &amp; "Cycle RGB Color"<br/>Replace faulty LED. Part # AALD27537 or AALD27538</p>   |

# TROUBLESHOOTING GUIDE

| Problem  | Probable Cause   | Remedy   |
|--|--|--|
| <p><b>Monitor not working.</b></p> <p>Power down, wait <b>5 minutes</b> and power up again.</p> <p>Game will load and play with the monitor unplugged.</p> | <p>Screen shows "No Signal Input"</p> <p>Note: Motherboard will boot up without the monitor plugged in.</p> <div style="display: flex; justify-content: space-around; align-items: center;"> <div style="text-align: center;">  <p><b>AAMB13-HD/RTR Motherboard</b></p> </div> <div style="text-align: center;">  <p><b>AAMB12-HD/RTR Motherboard</b></p> </div> </div> <p>Small power connector unplugged on motherboard</p> <p>Faulty or loose RAM</p> <p>Large power connector unplugged on motherboard</p> | <p>Monitor HDMI cable unplugged. There are 2 cables that are connected together - A5CORD37 and A5CORD36</p> <p>There are 2 possible motherboards in the game, refer to the picture that matches your motherboard:</p> <p>Faulty power supply - Refer to Power Supply diagnostic section.<br/>Faulty motherboard - Replace faulty motherboard.</p>  |
| <p>Screen has nothing at all on power up.</p>  | <p>Power cable unplugged from Monitor.</p> <p>Turn on Monitor.<br/>Faulty monitor.</p>   | <p>Ensure power is plugged into back of monitor, down to power strip. There are multiple power cords. Cable from Monitor, A5CORD1, and A5CORD5003</p> <p>Install batteries in remote control and try using remote control to power on monitor.<br/>Replace monitor. (A5MO5504)</p>   |
| <p>Error on screen at power up.</p> <p>Re-Boot game to see if problem still exists.</p>  | <p>Display shows "Kernel panic – unable to mount root"</p> <p>Display stuck on "Motherboard" Bios</p>   | <p>Faulty or loose RAM, faulty software, faulty Motherboard.</p> <p>Bad M.2 drive in motherboard.<br/>Reseat or replace M.2 Part # AAHD0032-RTR</p> <div style="display: flex; align-items: center; justify-content: center;">  <span style="margin: 0 20px;">Or</span>  </div> |
| <p><b>LED Lights around Front Speakers are not Working</b></p>   | <p>Loose or bad connection</p> <p>Test LED's in Diagnostic Menu</p> <p>Faulty LED</p>  | <p>Refer to wiring diagram. Check multiple connections, reseat cables from Light Board to Speaker Lights. CE27504 &amp; CE27506</p> <p>Enter menu, scroll to Diagnostic Menu, &amp; "Cycle RGB Color"</p> <p>Replace faulty LED. Left is AALD27535 Right is # AALD27534</p>  |

# TROUBLESHOOTING GUIDE

| Problem  | Probable Cause   | Remedy   |
|--|--|--|
| <p><b>Control Panel Buttons not Working</b></p>  | <p>Loose or bad connection.</p> <p>Test Switches in Diagnostic Menu</p> <p>Faulty Switch</p> | <p>Refer to wiring diagram. Check multiple connections and reseal cables from Light Board to Switches.<br/>Cables # CE27514 and CE27515</p> <p>Enter menu and scroll to Diagnostic Menu. The "Arrow Buttons" on screen will activate when the buttons are pressed.</p> <p>Replace faulty switch:<br/>Orange Circle Button is Part # A5BU27501<br/>Yellow Triangle Button is Part # A5BU27500</p> |
| <p><b>Camera not Working</b></p> <p>Camera will take pictures of high score players. This can be turned off in the menu.</p> | <p>Loose or bad connection.</p> <p>Faulty Camera</p>   | <p>Refer to wiring diagram. Check multiple connections and reseal cables from camera to motherboard.<br/>Cables # A5CORD32 which is plugged into the camera, and A5CE6601 which is plugged into the motherboard.</p> <p>Replace faulty camera. Part # AACM3001-RTR</p>   |
| <p><b>Static Zap from Game</b></p>   | <p>Faulty grounding from the metal plate in the rear play area.</p>                          | <p>Check CE275529 ground wire from the metal plate to the rear ground stud.</p> <div style="text-align: center;">  </div>   |

# CIRCUIT BOARD LAYOUT

Note: Rock the Rim games can use 2 different motherboards. The MB12 was the original motherboard. During March, 2023, this motherboard became obsolete and was changed to an MB13.

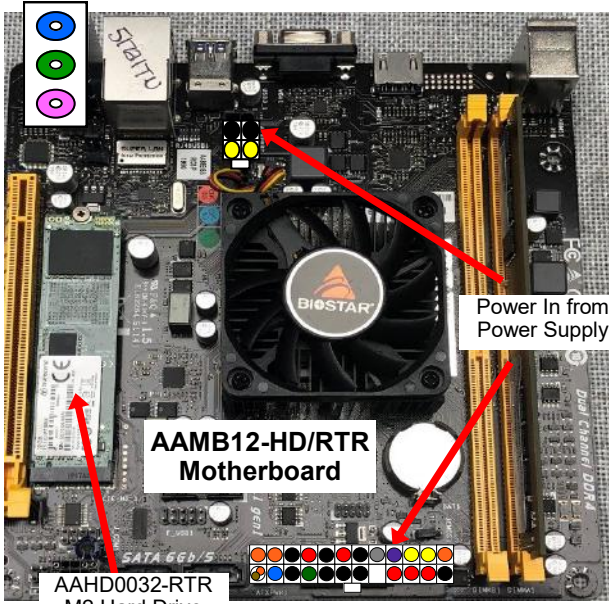

OR

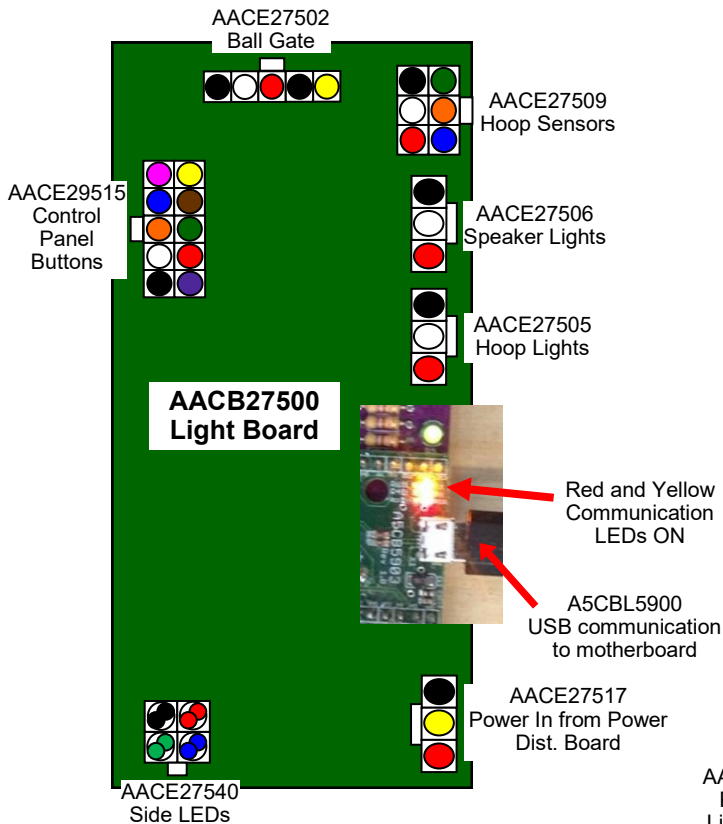
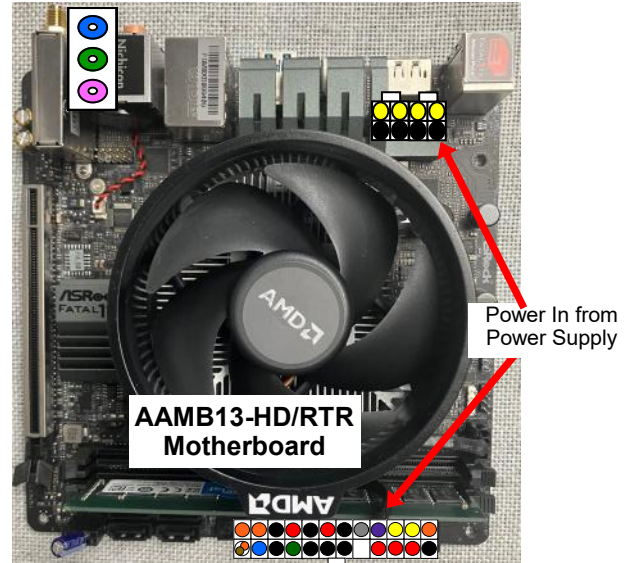

AAHD0032-RTR M2 Hard Drive  
Located on the bottom, underneath the motherboard



**Boards are located inside the front door, mounted to the left side of the game.**

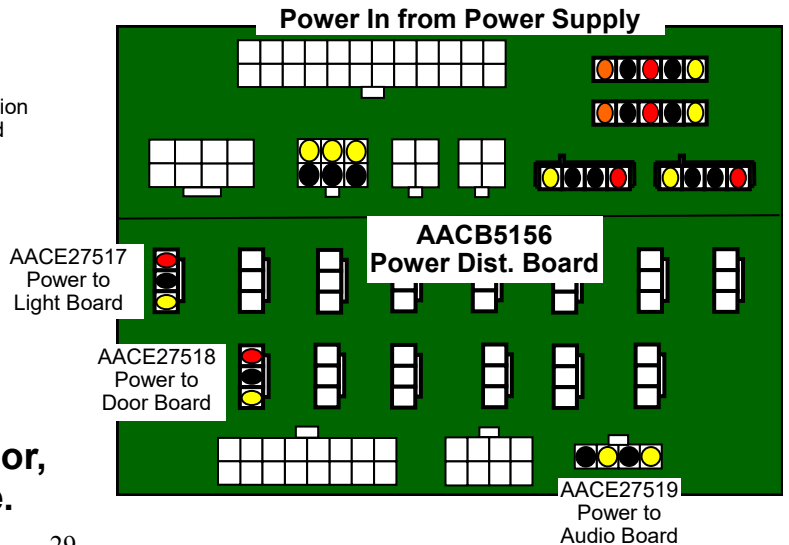

# CIRCUIT BOARD LAYOUT

Boards are located inside the front door, above the coin box.

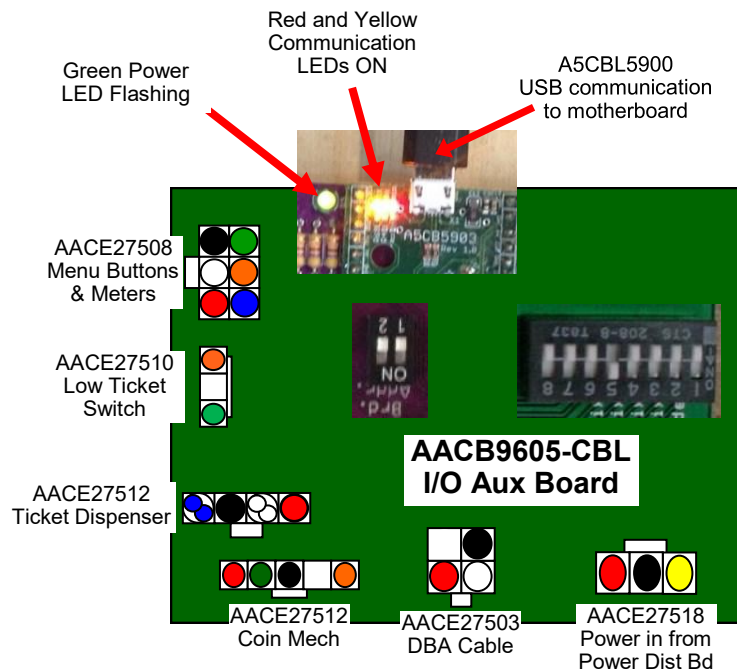
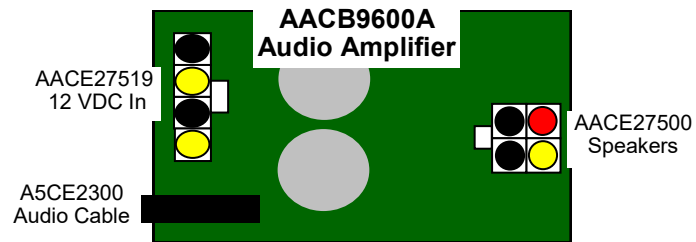

# WIRING DIAGRAM

## LEFT SIDE

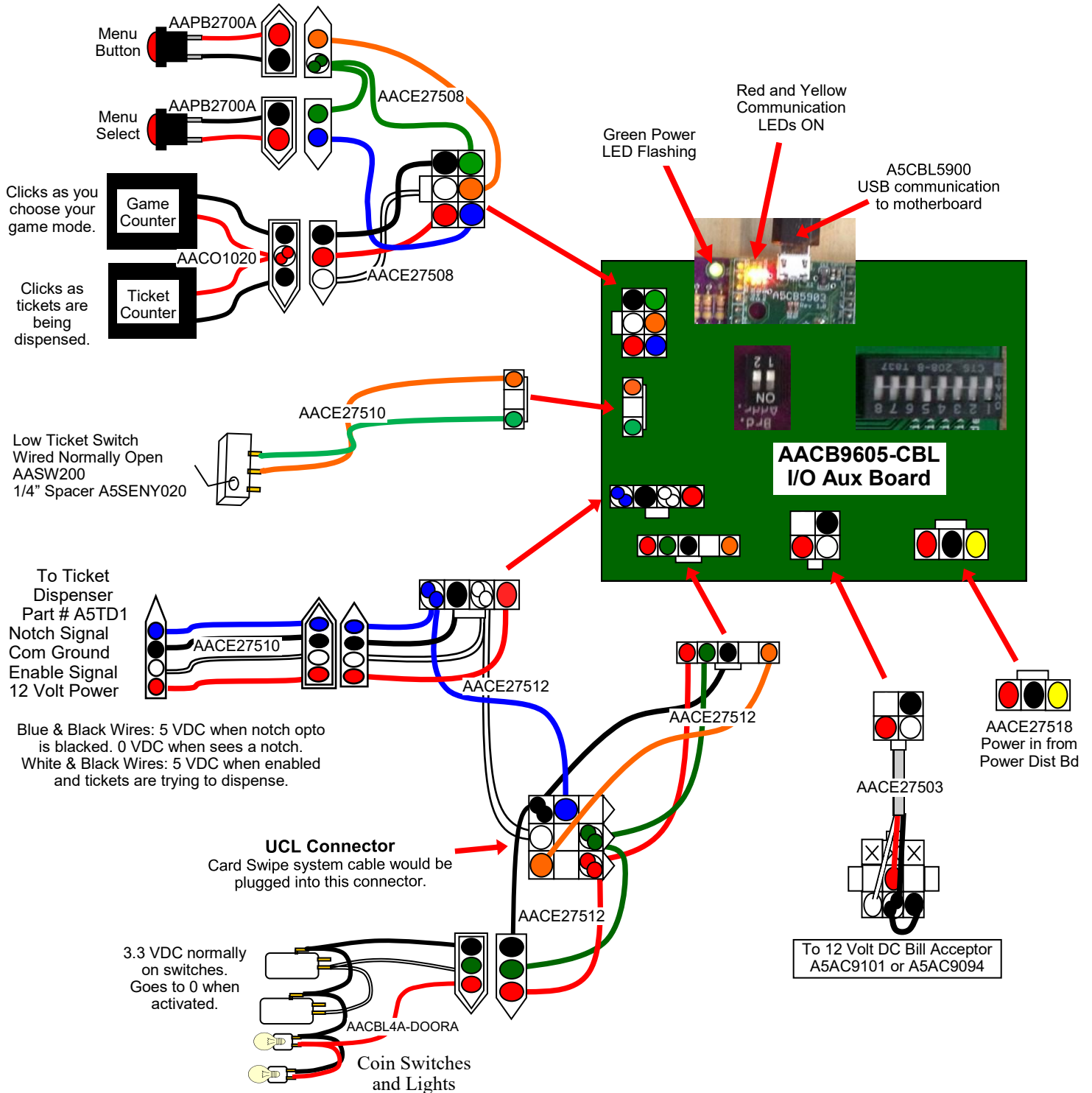

# COMMUNICATION WIRING DIAGRAM

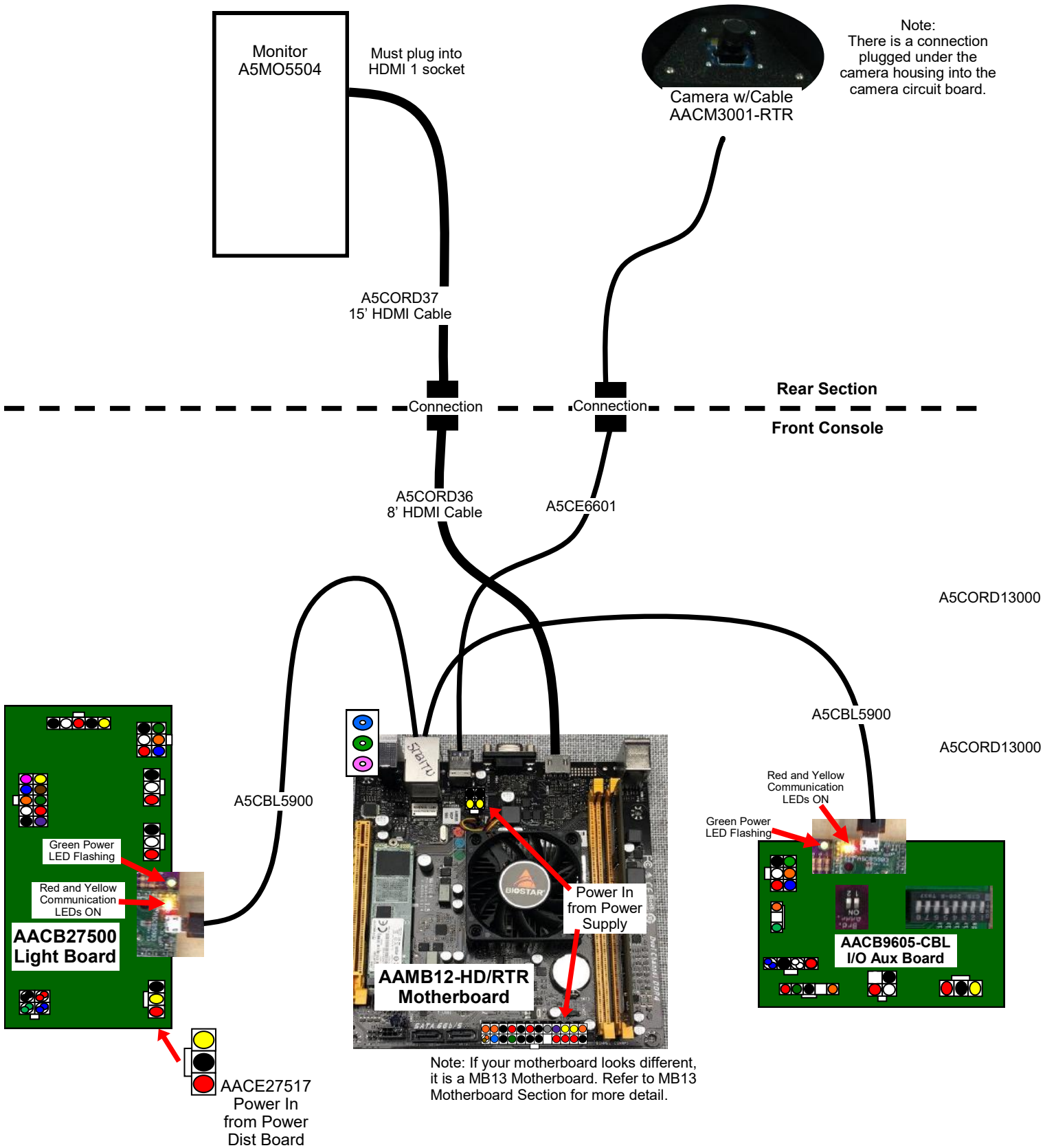

# SOUND WIRING DIAGRAM

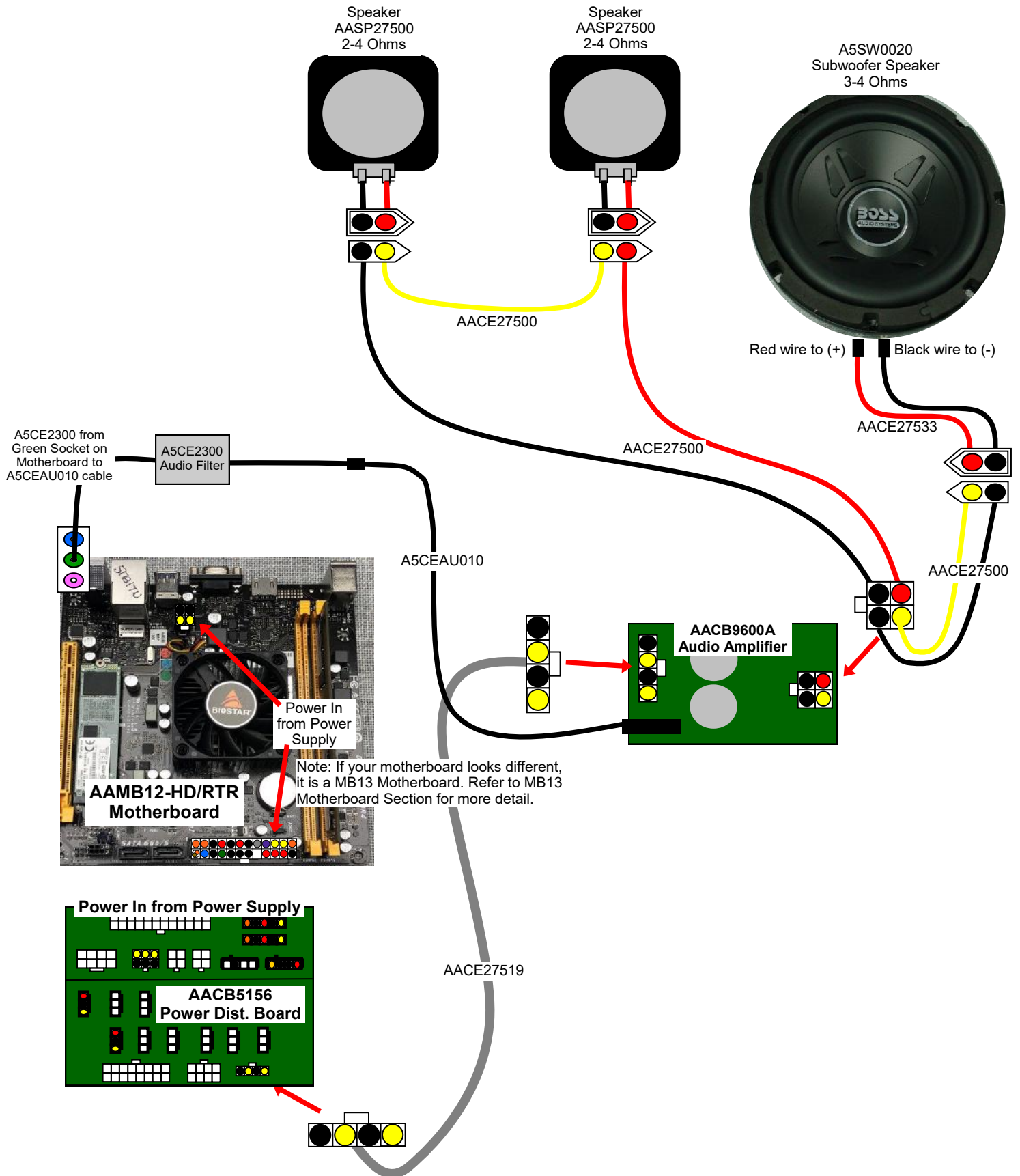

# BUTTON WIRING DIAGRAM

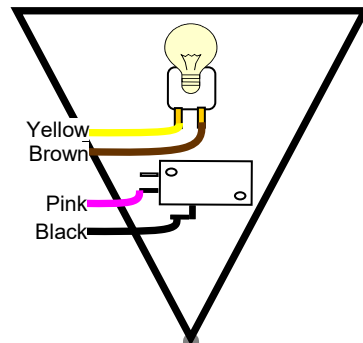
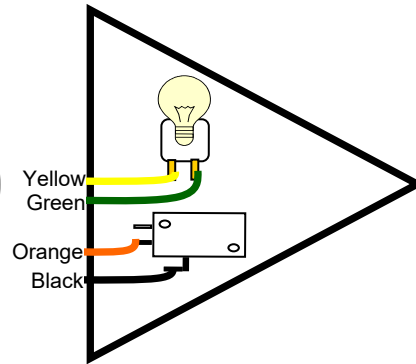
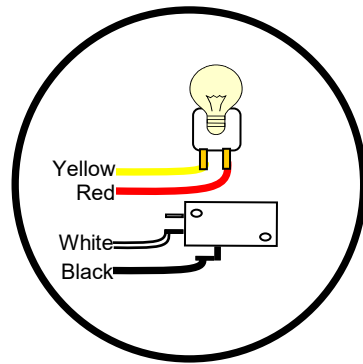
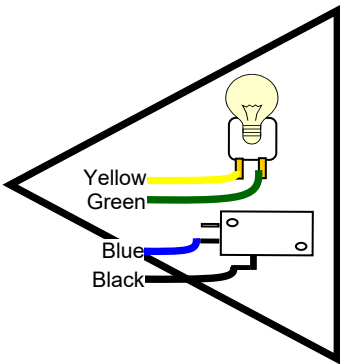
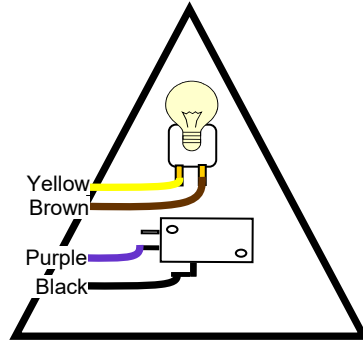

**Important:**  
Do not short Light Wires to anything.  
Switches wired Normally Open

Orange Circle Button  
Part # A5BU27501

Yellow Triangle Buttons  
Part # A5BU27500

AACE27514  
Cable to Switches



AACE27515

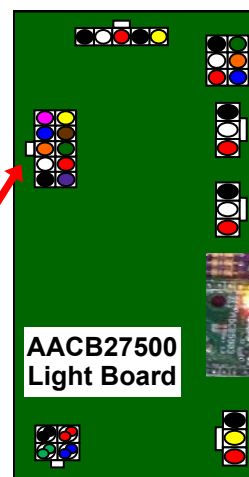
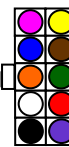

AACE27517  
Power In  
from Power  
Dist Board

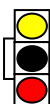

# HOOP SENSORS & BALL GATE WIRING DIAGRAM

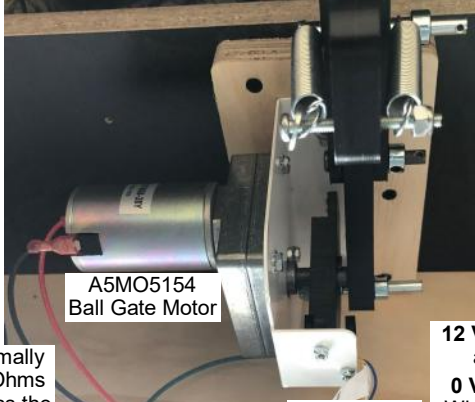

A5MO514  
Ball Gate Motor

AACB5190A  
Home Sensor

Normally  
14 Ohms  
across the  
motor.

**12 VDC** on the Yellow  
and Blue wires.  
**0 Volts** on Blue and  
White wires when the  
sensor is open.  
**4 Volts** on Blue and  
White wires when the  
sensor is blocked

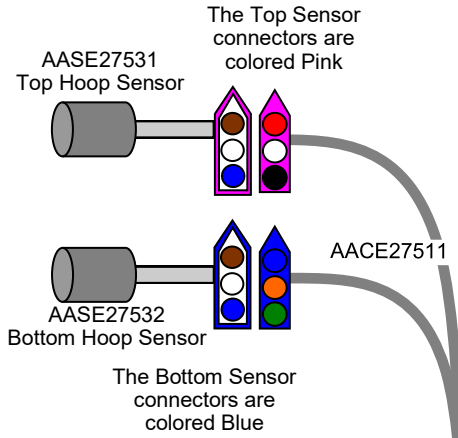

There are 2 Led's on sensors:  
Green is power  
Yellow is normally ON, and goes  
out when hoop is blocked.

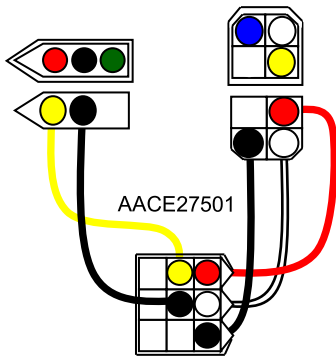

Rear Section

Front Console

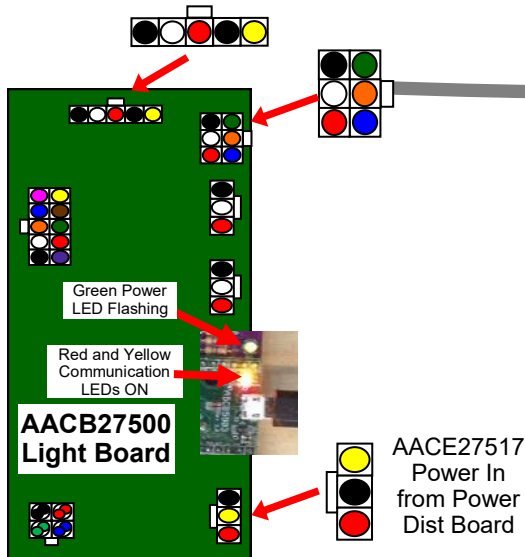
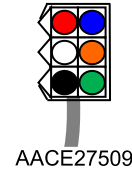

# GAME LIGHTING WIRING DIAGRAM

Note: 1 LED light strip can cause the other 3 to show incorrectly.  
 Unplug 2 of the 3 LED light strips to find the 1 faulty LED Light Strip.

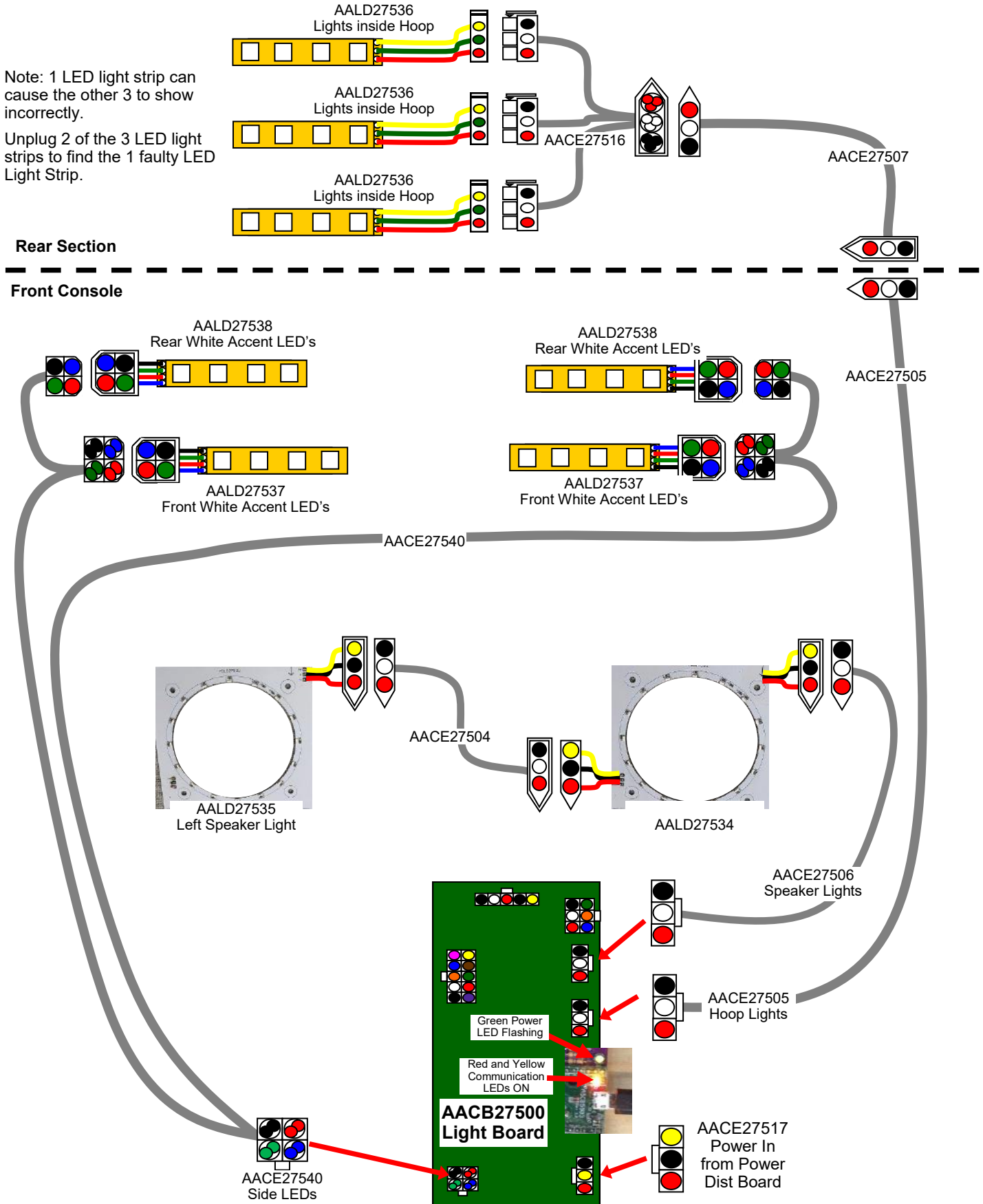

# AC POWER IN WIRING DIAGRAM

If the supply cord is damaged, it must be replaced by a special cord or assembly available from the manufacturer or its service agent

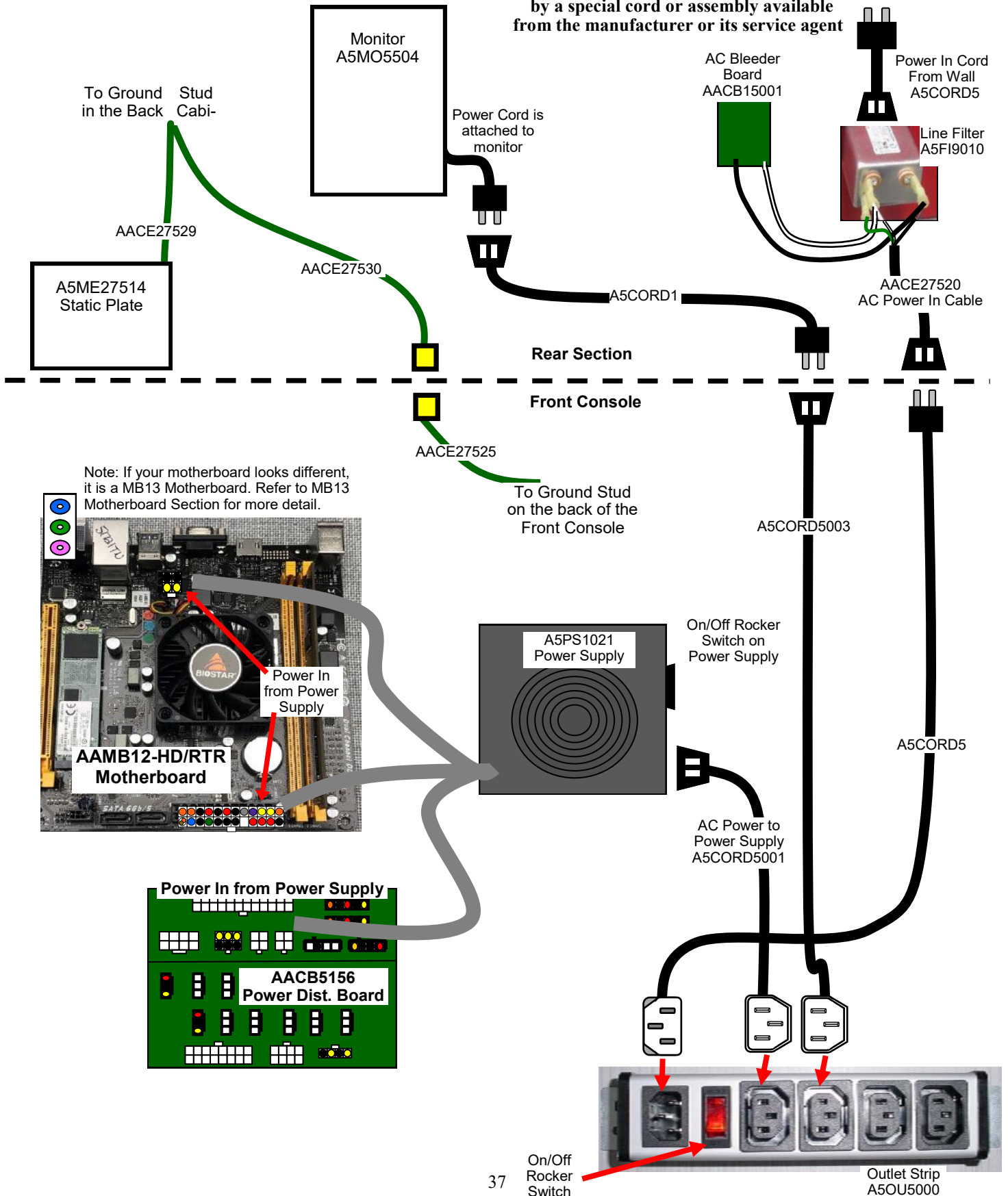

# MB13 MOTHERBOARD DIFFERENCES

Rock the Rim games can use 2 different motherboards. The MB12 was the original motherboard. During March, 2023 - the MB12 motherboard became obsolete and was changed to an MB13. These are the main differences:

## Difference # 1:

The additional power supply connection is 8 pins instead of 4 pins.

The older MB12 has one 4 pin connector pushed into motherboard, and one 4 pin connector loose.

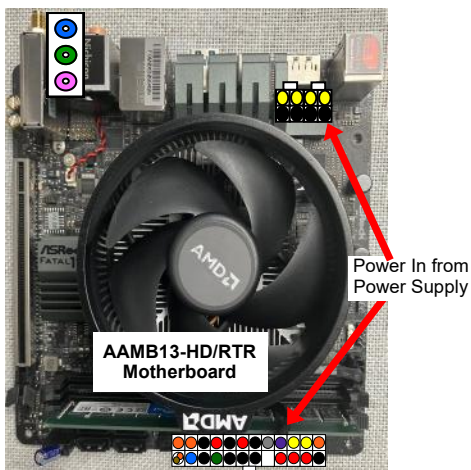
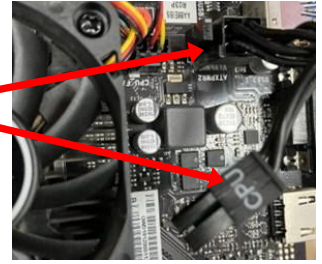

The MB13 uses both of these 4 pins pushed together to make one 8 pin connector.

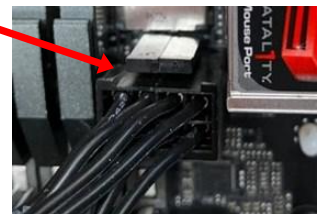
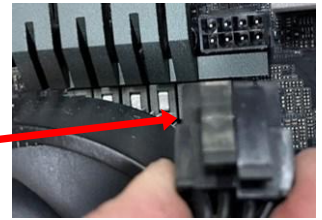

## Difference # 2:

The power on capacitor is located in a different location on the plug and it is now part # AACA1320-10



## Difference # 3:

The M.2 software drive ( Part # AAHD0032-RTR) is now located on the bottom, underneath the motherboard.



## Difference # 4:

There are more jacks on the motherboard, but the sound jack still plugs into the green socket.

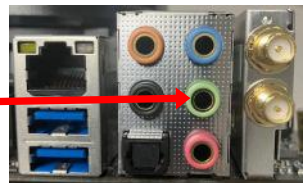

# SCORING ISSUES

## Information on Scoring:

There are 2 reflective sensors mounted on the back of the hoop.  
The game must “see” both of these sensors to score a basket.

It must first see the top sensor, then the bottom sensor. This sequence eliminates the “false score”.

The infrared light from the sensors bounce off the reflective tape in the front of the hoop and creates a beam. The ball will break this beam to score.



AATA8701 is the reflective tape.

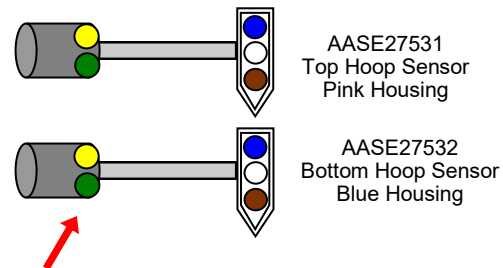

When beam is operating correctly, **both the yellow and green LED's will glow** on right side of sensors.

**If only the yellow LED is ON**, then the beam is not being reflected back at the sensor.

Check Reflective tape (AATA8701)

Ensure the housing assembly is pointing straight at reflective tape.

**If no LED's are ON**, then sensor is not getting power.

Check cables AACE27511 and AACE27509

Replace sensor. (AASE27531 or AASE27532)

**Note:** There is a small pot on the sensor itself that controls brightness. If this is turned up too far, the sensor will be too bright and overpower the other sensor.



# BALL GATE NOT OPERATING PROPERLY

The ball gate will normally be up to stop balls.

It will cycle down to allow balls to pass over it during game play.

To test - Press the menu button to enter the main menu.

Scroll to “Diagnostic”, press the menu select button.

Press the menu select button on “Open Gate” to open the ball gate.

Verify that the balls roll smoothly to the player.

Press the menu select button on “Close Gate” to close the ball gate.

Verify that the balls are being blocked by the ball gate.

If any adjustments need to be made for the ball gate height, refer to **“How to Adjust the Ball Gate”**

The ball gate movement is controlled by a sensor attached to the motor.

The sensor watches a cam with a solid end and a forked end.

- When the gate is up, the motor will stop past the forked end of the cam.

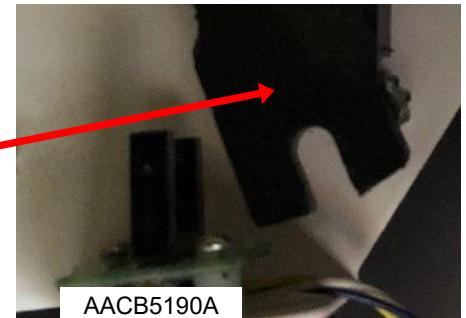

- When the gate is down, the motor will stop past the solid end of the cam.

If the ball gate is constantly going up and down over and over, this sensor is not seeing the cam at all. Check cable connections and replace sensor if needed.

If the motor is not turning at all, refer to wiring diagrams and check wiring, check for 12 volts DC at the motor while selecting open/close gate in the menu. Normally 14 Ohms across the motor.

Replace motor if needed. Part # A5MO5154

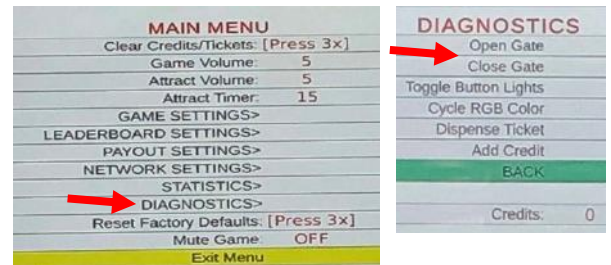

# POWER SUPPLY DIAGNOSTICS

- 1.) Verify AC power to game. Check power strip in front door. The rocker switch should be illuminated.
- 2.) Check connection to power supply.
- 3.) Ensure Power Supply switch is set to 115V (or 230V)  
(Some model power supplies may not have this)
- 4.) Ensure Power switch is on.
- 5.) Ensure fan is turning.

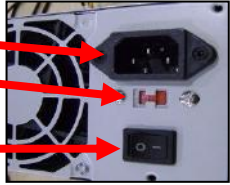

- If power supply fan is turning and there is no 12 Volt out:  
Check power supply cables to the Power Distribution Board.  
This board takes the power in, and directs it to the different 12 volt loads.

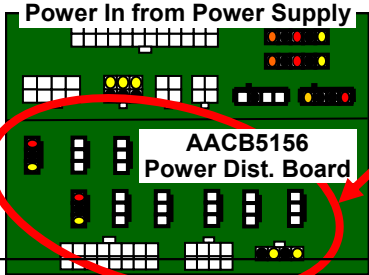

- Replace power supply if this board is not receiving 12 volts. (A5PS1021)
- Unplug all power out connectors from the right side of the Power Distribution Board. Turn on game and if it boots correctly, plug one cable in at a time until the issue is found.
- If power supply fan is not turning, then continue to "Verify Power to Motherboard"

## Verify Power to Motherboard

The motherboard will turn on power supply.  
If your game has no 12 volts, it may be the motherboard not turning on.  
Also - there may be a 12 volt short somewhere in cabinet that is not allowing the power supply to turn on.

### AAMB12-HD/RTR

Make sure the 4 pin power connector is plugged in.  
(Black, Black, Yellow, Yellow)  
As well as 24 pin power in connector.

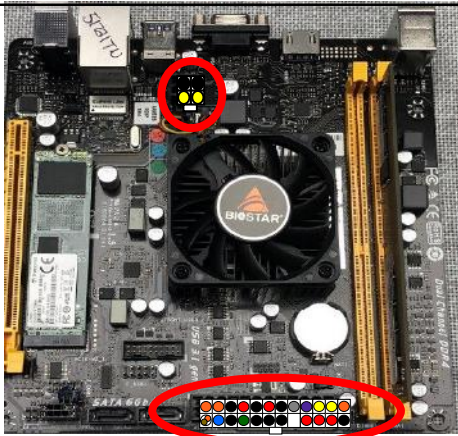

### AAMB13-HD/RTR

Make sure the 8 pin power connector is plugged in.  
(2 of 4 pin connectors together)  
As well as 24 pin power in connector.



OR

## Minimize load on power supply and isolate short

Unplug the power supply cables going to the Power Distribution Board.  
This will leave the power supply, motherboard, and monitor left plugged in together.

If power supply, motherboard, and monitor now turn on:  
Plug in the Power Distribution Board to power supply, but unplug all of the outputs from the board.  
Turn on game and verify the 12 volts is good.  
Then plug in one component at a time to power supply to locate short.

If power supply still does not power on:  
Replace power supply (A5PS1021), or motherboard. (AAMB13-HD/RTR)

# BILL ACCEPTOR DIAGNOSTICS

**Note:** There are many different models and brands of Bill Acceptors that are used on redemption games. Your Bill Acceptor may differ from the unit shown. Standard DBA is MEI # AE2454-U5E Part # A5AC9101

Determine if Bill Acceptor has power:

Turn game ON—The bill acceptor should make noise as stacker cycles and green lights on outside bezel should flash.

If NO power:

Use meter to measure 12 VDC voltage at cable going into Bill Acceptor from front I/O Aux Board

If power is OK:

Clean Bill Acceptor path to make sure there is nothing jamming unit.

Check dipswitch settings on side of acceptor.

**Make sure switch # 8 is OFF for Always Enable**



## ERROR CODES

Count the number of flashes on front bezel of Bill Acceptor and follow on Bill Acceptor chart for repair instructions.

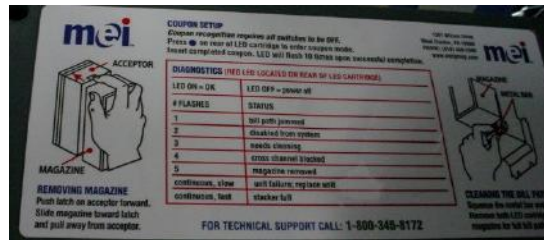

# BLANKING PLATES AVAILABLE

A5PL4200 DBA Plate used for Upstacker Bill Acceptor

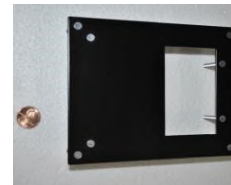

A5PL9998 Plate used instead of Coin Mechanisms



A5PL8900 Plate used for Bill Validator



A5PL9995 Plate used instead of ticket dispenser



# HOW TO ADJUST THE BALL GATE

If the ball gate is not opening fully, or blocking balls when it is open, the metal motor mount must be adjusted up or down.

This ball gate motor mount is covered by a black plastic panel.

Remove this panel by removing the 4 screws using a # 2 square bit.

Verify the ball gate opens and closes cleanly and is set to the correct height to stop balls:

Press the menu button to enter the main menu.

Scroll to “Diagnostic”, press the menu select button.

Press the menu select button on “Open Gate” to open the ball gate.

Verify that the balls roll smoothly to the player.

Press the menu select button on “Close Gate” to close the ball gate.

Verify that the balls are being blocked by the ball gate.

If any adjustments need to be made for the ball gate height, loosen the 2 bolts holding the assembly to the wood using a 7/16” wrench.

Re-position the assembly in the appropriate direction and re-tighten the bolts.

Test again using the menu buttons in the diagnostic menu.

When the ball gate height is correct, the black plastic cover can be attached to the bottom of the game. This will protect the wires and motor from curious fingers.

Slide the thin black plastic panel into position under the cabinet, sliding the notches into the wood.

Secure the panel using the 4 screws using a # 2 square bit.

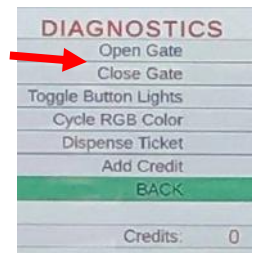
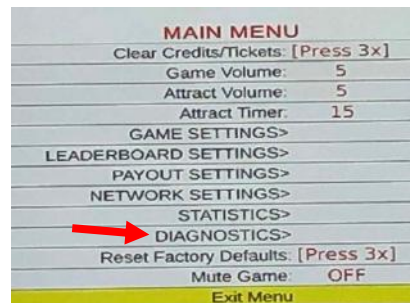
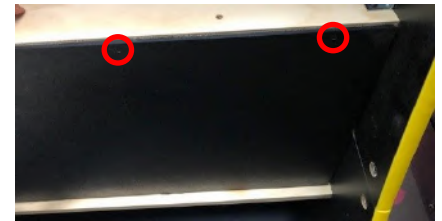

# HOW TO REPLACE SCORE SENSORS

To change a score sensor, the bracket which both sensors mount to must be removed from the cabinet.

Then the sensor can be changed and the bracket reinstalled into the cabinet.

Directions:

Open the back door about 2 feet, remove the 3 screws on back door using a Phillips screwdriver.



Remove 4 nuts using a 11/32" socket. (You might need a friend to hold the bolts from inside the cabinet.)

Carefully cut plastic wire ties.

Unplug both pink and blue cables.

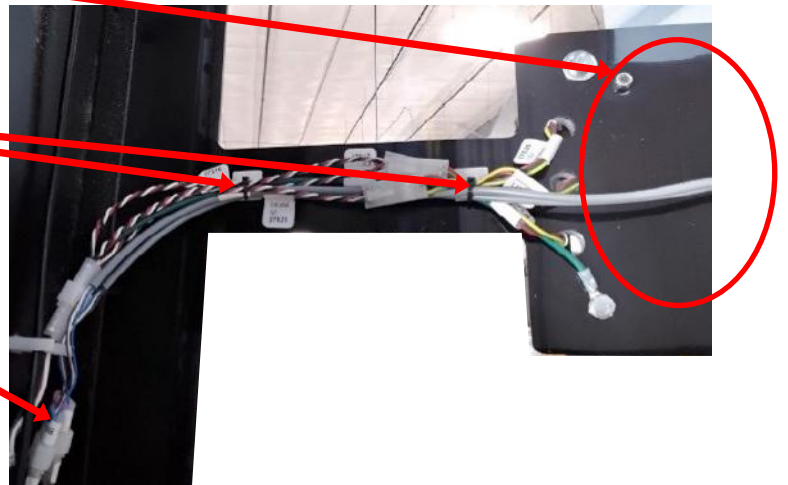

Carefully climb inside the game, remove the bracket holding both sensors.

The sensor can now be changed.



# HOW TO CHANGE SOFTWARE ON MB12

Rock the Rim games can use 2 different motherboards.

This MB12 is the original motherboard.

During March, 2023, this motherboard became obsolete and was changed to an MB13.

These instructions will detail how to change software on the MB12.

This is the M.2 Drive as a hard drive with software.



This M.2 Drive is located here on the motherboard.

Remove this screw with a small #1 Phillips screwdriver.

There is a small white plastic spacer under the screw.

Leave this on the board, the M.2 drive will rest on top of this spacer.



Slide the M.2 new software drive into the slot on the motherboard as shown.

Notice the white spacer is still on the motherboard.



Using a small # 1 screwdriver, re-insert the screw into the motherboard to secure the software.



# HOW TO CHANGE SOFTWARE ON MB13

Rock the Rim games can use 2 different motherboards.  
The MB12 was the original motherboard which became obsolete and was changed to an MB13 during March 2023.

This is the MB13 motherboard



These instructions will detail how to change software on the MB13.

This is the M.2 Drive as a hard drive with software.



This M.2 Drive is located on the bottom, underneath the motherboard.



Remove this screw with a small #1 Phillips screwdriver.



Slide the M.2 new software drive into the slot on the motherboard as shown.



Using a small # 1 screwdriver, re-insert the screw into the motherboard to secure the software.



# HOW TO REPLACE MONITOR

As monitors become obsolete and unavailable, replacement monitors will require a different mounting process or wood pieces to enable the new monitor to fit and function. As such, your new monitor has been delivered with the hardware necessary to adapt the monitor for use with your game.

These instructions will show how to prepare the new monitor for your cabinet.

## **Tools Needed:**

5/32" Allen Wrench  
7/16" socket  
Phillips Screwdriver

## **Hardware Included:**

Plywood Mounting board  
4x Black 20mm Pan Head Screws  
8x Flat 1/4" Washers

## **Instructions:**

### **Preparing the new monitor**

-Locate the plywood mounting board.

-With the countersunk holes facing upward, line up the holes in the board with the mounting inserts on the back of the monitor.

-Locate the 4 Black panhead screws.

-Place 2 flat washers onto each screw and insert them into the countersunk holes of the mounting board.

-Use a 5/32" Allen Wrench to tighten the four screws as much as possible and secure the mounting board to the tv.



# HOW TO REPLACE MONITOR

The monitor is replaced from the back of the game.

Instructions:

1 - Remove the 6 screws from plastic plate using a # 2 square bit.



2 - Unplug the HDMI cable from the HDMI 1 socket. Carefully snip the plastic wire tie holding the cable.

3 - Remove the 3 screws on the right edge of back door using a Phillips screwdriver. Save this hardware for later.

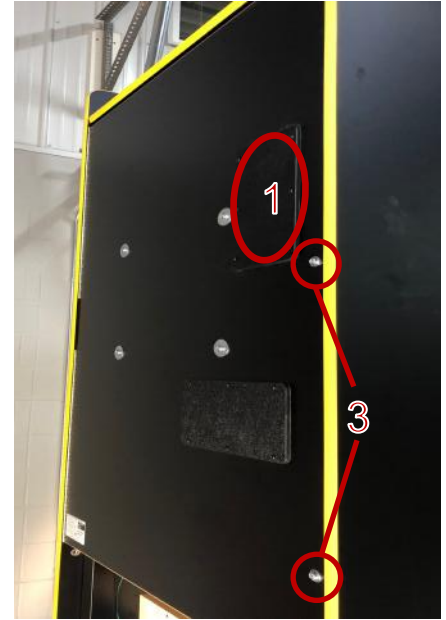

4 - Locate the power cable from the monitor and remove the cable from the clips.

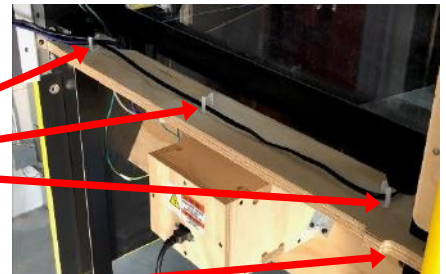

5 - Unplug the monitor's power cable from this outlet.

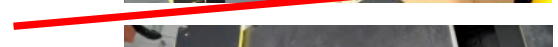

6 - Using 2 people - Remove the 4 bolts from the back of the game that holds the monitor in place. Carefully remove the monitor from the cabinet as the last of the 4 bolts is removed. Make sure to save the hardware.



7 - Remove the plywood on the back of the old monitor.



Reuse the hardware to secure this piece on top of the mounting board attached to the new monitor.

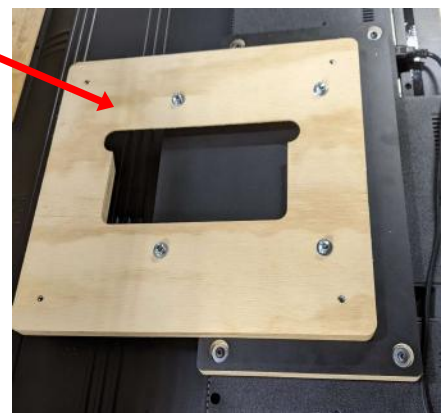

# HOW TO REPLACE MONITOR

8 - Carefully lift the monitor and seat the mounting bracket on top of the mount support located on the monitor door of your game's cabinet. These pieces are angled in such a way that they should nest together comfortably.

9 - With the hardware saved from earlier, secure the monitor to the monitor door.

10 - Make sure to plug the HDMI cable that was disconnected earlier into the HDMI 1 port.

Close the monitor door and replace the three screws removed earlier to secure it back in place. Reinstall the metal cover that was removed earlier to protect the HDMI and power connectors.



---

The installation of the new monitor is now complete. Please turn on your game and ensure that everything operates and displays as it should.

Please call Baytek Entertainment with any further questions at (920) 822-3951 Ext. 1102

# HOW TO REPLACE MONITOR

Once the new monitor has been turned on, it will need to be set up using the remote control that is included.

Press “Exit” on the remote control.

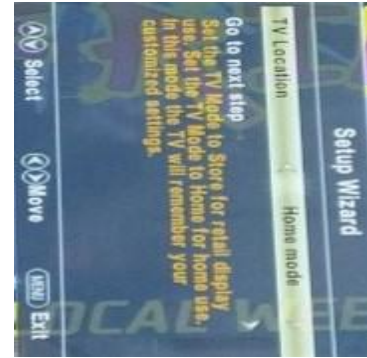

Press “Menu” on the remote control.



Scroll to the “Advanced Settings”



Enter the “HDMI Mode”



Set to “Graphic Mode” and press the “OK” button on the remote.

Press “Exit” on the remote.



# I/O BOARD DIPSWITCH SETTINGS

| SWITCH | DESCRIPTION   | ON | OFF |
|--------|---|----|-----|
| 1      | <b>SHOW GAME</b><br>Does not dispense tickets and clears all accumulated credits if ON  |    | X   |
| 2      | <b>AMUSEMENT ONLY</b><br>Does not dispense tickets if ON  |    | X   |
| 3      | <b>NJ LOCKOUT</b><br>Saves tickets owed and unused credits after a power loss if ON   |    | X   |
| 4      | <b>1/2 TICKET PAYOUT</b><br>Dispenses 1/2 the amount of tickets as shown on screen. It will round up odd amounts of tickets if ON                 |    | X   |
| 5      | <b>DISABLES LOW TICKET INPUT</b><br>Disables the low ticket message on screen if ON. This option should be enabled when using a card swipe system | X  |     |
| 6      | <b>NOT USED</b>   |    |     |
| 7      | <b>NOT USED</b>   |    |     |
| 8      | <b>NOT USED</b>   |    |     |

Note: Make sure that both dipswitches on this bank of 2 are both Off.

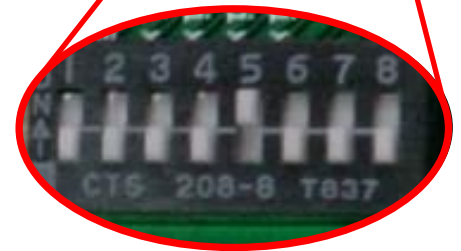

# I/O AUX BOARD PINOUT



- = +12 VDC
- = Ground
- = +5 VDC
- = Output
- = Input

**Outputs:**

- Q1 (PD1) Game counter
- Q2 (PD0) Tickets counter
- Q3 (PD6) Coin Lockout
- PE6 Ticket Enable

**Inputs:**

- PD4 Menu Button
- PC6 Select Button
- PD7 Ticket Notch
- PB4 Coin In
- PB5 DBA In
- D15 (A1) Low Ticket Switch Input

# BALL GATE EXPLODED VIEW

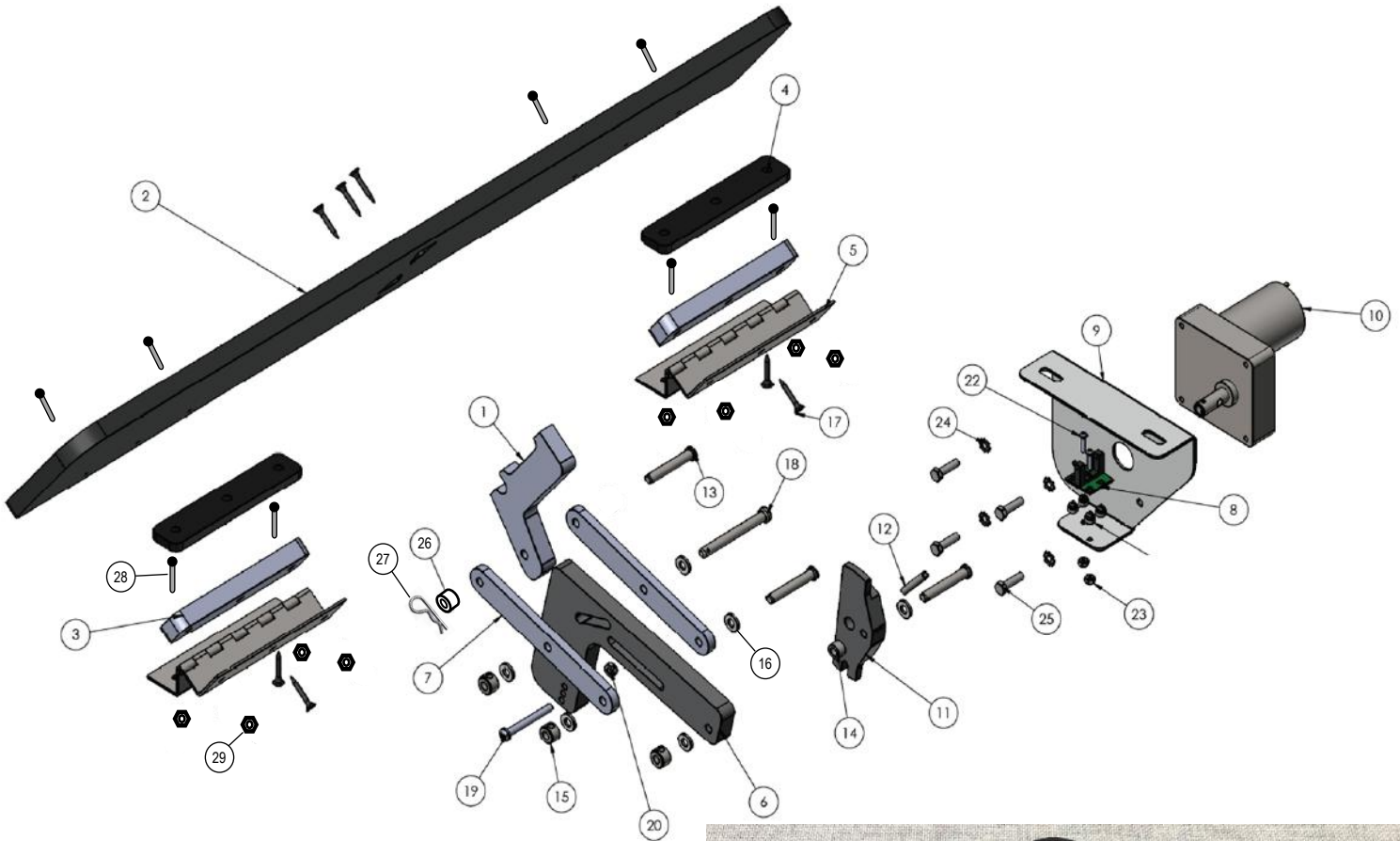

| Item # | Part Number | Description         | Qty |
|--------|-------------|---------------------|-----|
| 1      | WACA27508   | Ball Gate Arm       | 1   |
| 2      | WACA27509   | Ball Gate Arm       | 1   |
| 3      | WACA27524   | Gate Shim           | 2   |
| 4      | WACA27523   | Gate Shim, Thinner  | 2   |
| 5      | W5HG1015-1  | Double Bend Hinge   | 4   |
| 6      | WACA27577   | Spring Loaded Link  | 1   |
| 7      | WACA10041   | Link                | 2   |
| 8      | AACB5190A   | Sensor              | 1   |
| 9      | A5ME1727    | Motor Bracket       | 1   |
| 10     | A5MO5154    | Motor               | 1   |
| 11     | WACA10121   | Motor Arm           | 1   |
| 12     | A5PIRO015   | 1" Long Roll Pin    | 1   |
| 13     | A5PICV032   | Clevis Pin          | 3   |
| 14     | A5SENY175   | Nylon Washer        | 1   |
| 15     | A5SLL0020   | Shaft Collar        | 4   |
| 16     | A5WANY050   | Nylon Washer        | 6   |
| 17     | A5SCFH030   | 1" Bugle Screw      | 4   |
| 18     | A5PICV045   | Clevis Pin 2 1/2"   | 1   |
| 19     | A5BOPH190   | 10-24 x 1 3/4" Bolt | 1   |
| 20     | A5NUNY040   | Nylon Lock Nut      | 1   |
| 21     | A5SFNY010   | Nylon Spacer        | 4   |

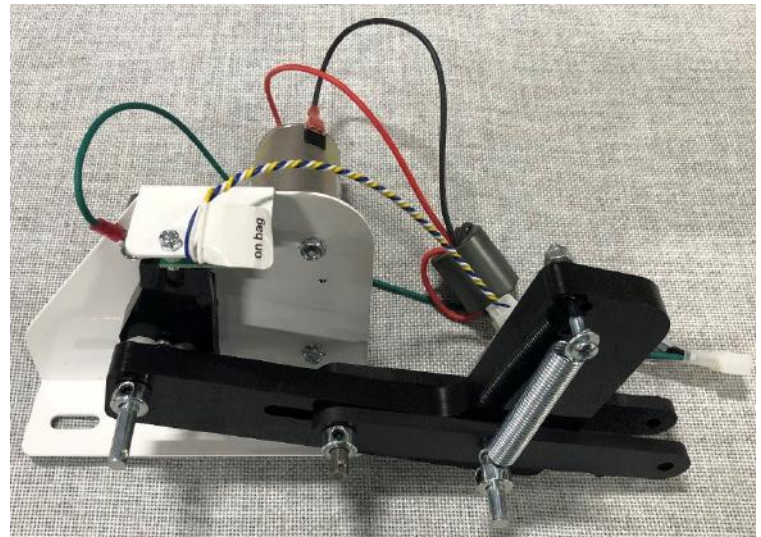

| Item # | Part Number | Description         | Qty |
|--------|-------------|---------------------|-----|
| 22     | A5BOPH030   | Board Stand Off     | 2   |
| 23     | A5NUNY020   | Nylon Lock Nut      | 2   |
| 24     | A5WAET020   | Tooth Lock Washer   | 4   |
| 25     | A5BOHH030   | 10-32 X 3/4"        | 4   |
| 26     | A5SENY170   | 1/4" Spacer         | 2   |
| 27     | A5CL3401    | Hitch Pin Clip      | 1   |
| 28     | A5SCPH255   | 10-24 x 1.5 Screw   | 8   |
| 29     | A5NUNY050   | 10-24 Nylon Hex Nut | 8   |

# DECAL DIAGRAM

A5DE26500 Control Panel Decal  
 WACA26515 Plexi covering Decal



A5DE27503 Right Side Upper Decal  
 (A5DE27504 other side)

WACA27537 Rear Side Window (2 per Game)

WACA27522 Front Side Window (2 per Game)

WACA27512 Ball Guard Acrylic

A5DE27507 Speaker Decal



A5DE27500 Control Panel Decal

A5DE27501 Right Side Decal  
 (A5DE27502 other side)

A5DE27505 Front Door Outer Decal

A5DE27506 Front Door Inner Decal

# PARTS PICTURES

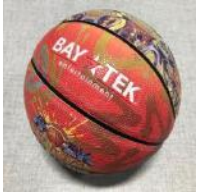

A5BA27000



A5BK9999



A5BU27500



A5BU27501



A5CA1005

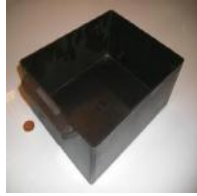

A5CB2020



A5CL3401



A5KIT-RTR



A5LK2001



A5LK5002



A5LV10000



A5PICV032



A5PL4200



A5PL8900



A5PL9995



A5PL9998



A5SENY170



A5SP10000



A5VF4153



A5WSFO015



AAPB2700A



AAHP27500

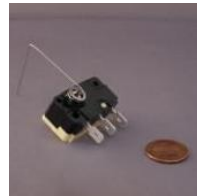

AASW200



AATA8701

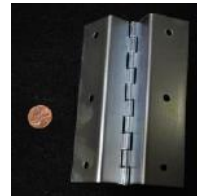

W5HG1015



W5HG1025



W5HG1030



W5HG1065

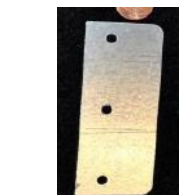

W5KE5000



W5TM4006



A5ME1727

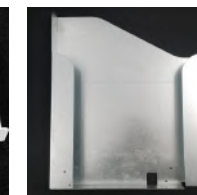

A5ME2034



A5ME27500



A5ME27501



A5ME27502



A5ME27516



A5ME27504



A5ME27505



A5ME27506



A5ME27507



A5ME27509-1



A5ME27509-2



A5ME27512



A5ME27513



A5ME27514



A5ME4182



AABK1013



AAME27515

# PARTS PICTURES



**A5CBL5900 A5CE2300 A5CE6602 A5CEAU010 A5CORD1 A5CORD36 A5CORD37 A5CORD5**



**A5CORD5001 A5CORD5003 A5OU5000 AACBL4A-DOORA AACE1710 AACE1715 AACE27500 AACE27501**



**AACE27502 AACE27503 AACE27504 AACE27505 AACE27506 AACE27507 AACE27508 AACE27509**



**AACE27510 AACE27511 AACE27512 AACE27540 AACE27514 AACE27515 AACE27516 AACE27517**



**AACE27518 AACE27519 AACE27520 AACE27521 AACE27522 AACE27523 AACE27524 AACE27525**



**AACE27526 AACE27527 AACE27528 AACE27529 AACE27530 AACE27533 AACE27539**



**AACO1020 AALD27534 AALD27535 AALD27536 AALD27537 AALD27538 AASE27531 AASE27532**

# PARTS PICTURES



A5SW0020



A5DE0042



A5DE0056



A5DE0114



A5DE27500



A5DE27501



A5DE27502



A5DE27503



A5DE27504



A5DE27505



A5DE27506



A5DE27507



WACA27506



WACA27512



WACA27522



WACA27537



A5AC9101



A5FI9011



AACB9600A



A5MO5154

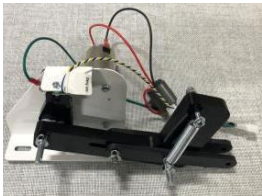

AABR27500



AAKIT-RTR-BR



A5MO5504



A5PS1021



A5TD1



AACB15001



AACB27500



AACB5156



AACB5190A



AACB9605-CBL



AACM3001-RTR



AAHD0032-RTR



AAMB12-RTR



AAMB13-HD/RTR

# PARTS LIST

| <b>PART #</b> | <b>DESCRIPTION</b>                          | <b>PART #</b> | <b>DESCRIPTION</b>                        |
|---------------|---|---------------|---|
| A5BA27000     | Basketball W/ Logo, Size 5, 6 Per Game      | A5ME4182      | Metal, Cashbox Guide                      |
| A5BK9999      | Bracket, Power Supply Mounting              | AABK1013      | Bracket, Pushbutton/Counters              |
| A5BU27500     | Button, Yellow Triangle, 12v, 4 Per Game    | AAME27515     | Metal, Speaker Box with Decal             |
| A5BU27501     | Button, Basketball, 12v White Led           | A5CBL5900     | Cable, USB, Male A to Male Micro, 2/Game  |
| A5CA1005      | Caster, 250# Load, Swivel/Lock, 4/Game      | A5CE2300      | Cable, Audio Isolator                     |
| A5CB2020      | Cash Box                                    | A5CE6601      | Cable, USB, 6', Extension, Black          |
| A5CL3401      | Clip, Hitch Pin, 5/64x1-3/16                | A5CEAU010     | Cable, Audio Stereo, 3.5mm, M-M 2ft       |
| A5LK2001      | Lock, Cash Box, A05/E00 Key Code            | A5CORD1       | Cord, Power, 10' Works W/Outlet Strip     |
| A5LK5002      | Lock, 7/8", H95 Key Code                    | A5CORD36      | Cord, 8' Hdmi to Hdmi                     |
| A5LV10000     | Leg Levelers, 6 Per Game                    | A5CORD37      | Cord, 15' Male to Female HDMI             |
| A5PICV032     | Pin, Clevis, 1.4"D X 1-5/8"L                | A5CORD5       | Cord, AC Computer Cord, 6.5', 2 Per Game  |
| A5PL4200      | DBA Plate for Upstacker 12 Volt DBA         | A5CORD5001    | Cord, Extension, C14 To C13, 16ga, 2ft.   |
| A5PL8900      | Plate, Bill Validator Blanking Plate        | A5CORD5003    | Cord, Power Adapter, C14 To 5-15, 6ft.    |
| A5PL9995      | Plate Used Instead of Ticket Dispenser      | A5OU5000      | Outlet Strip, W/2 Clips, C13out, C14inlet |
| A5PL9998      | Plate Used Instead of Coin Mechanisms       | AACE1710      | Cable, 4" Door Ground Cable               |
| A5SENY170     | 1/4" Hole X 1/2" Od X 1/4"                  | AACE1715      | Cable, Door Ground Cable, 2 Per Game      |
| A5SP10000     | Spring, Extension, 7/16 X 2-3/4, 2/Game     | AACE27500     | Cable, Speakers Power                     |
| A5VF4153      | Vacuum Form, Handle Cover                   | AACE27501     | Cable, Motor & Ball Gate Sensor           |
| A5WSFO015     | 1/4" Thick, 3/8" Wide, 50'l, Black, 5"/Game | AACE27502     | Cable, Motor & Ball Gate Sensor Power     |
| AAPB2700A     | Push Button Assembly, 2 Per Game            | AACE27503     | Cable, Dollar Bill Acceptor               |
| AAHP27500     | Hoop Assembly, Rock The Rim                 | AACE27504     | Cable, Speakers Addr. Light Jumper        |
| AASW200       | Switch, Score/Low Ticket Switch             | AACE27505     | Cable, Hoop Addr. Light Power             |
| AATA8701      | Tape, Reflective                            | AACE27506     | Cable, Speakers Addr. Light Power         |
| W5HG1015      | Hinge, 5", Double Bend, 2 Per Game          | AACE27507     | Cable, Hoop Addr. Light Power             |
| W5HG1025      | Hinge, 16", Double Bend                     | AACE27508     | Cable, Menu and Counters                  |
| W5HG1030      | Hinge, 23", Single Bend, 2 Per Game         | AACE27509     | Cable, Hoop Sensor Power                  |
| W5HG1065      | Hinge, 5-75, Single Bend                    | AACE27510     | Cable, Ticket Dispenser                   |
| W5KE5000      | Keeper, Lock                                | AACE27511     | Cable, Hoop Sensors                       |
| W5TM4006      | T-Molding, 13/16", Yellow, 124 Feet/Game    | AACE27512     | Cable, Coin Door                          |
| A5ME1727      | Metal, Motor Bracket                        | AACE27540     | Cable, Side Rgb Lights Power              |
| A5ME2034      | Ticket Tray, 20 Ga Galvanized               | AACE27514     | Cable, Panel Buttons                      |
| A5ME27500     | Metal, Center Connector, 2 Per Game         | AACE27515     | Cable, Panel Buttons Power                |
| A5ME27501     | Metal, Rear Connector, 6 Per Game           | AACE27516     | Cable, Hoops Lights Power Jumper          |
| A5ME27502     | Metal, Framing Connector, 2 Per Game        | AACE27517     | Cable, Power to Cb27500                   |
| A5ME27516     | Metal, Control Panel                        | AACE27518     | Cable, Power to Cb9605a                   |
| A5ME27504     | Metal, Rim Bracket, 2 Per Game              | AACE27519     | Cable, Power to Cb9600                    |
| A5ME27505     | Metal, Reflector Plate                      | AACE27520     | Cable, Line Filter                        |
| A5ME27506     | Metal, Sensor Bracket, 18 Ga                | AACE27521     | Cable, Hoop Sensor Ground                 |
| A5ME27507     | Metal, Backboard Rail, 2 Per Game           | AACE27522     | Cable, Hoop Rim Ground                    |
| A5ME27509-1   | Metal, Leg, 2 Per Game                      | AACE27523     | Cable, Button Panel to Door Hinge         |
| A5ME27509-2   | Metal, Leg Horizontal                       | AACE27524     | Cable, Door Hinge to Ticket Dispenser     |
| A5ME27512     | Metal, Side Guard, 2 Per Game               | AACE27525     | Cable, Front Ground Stud to Back Stud     |
| A5ME27513     | Metal, Ball Guard Mount, 2 Per Game         | AACE27526     | Cable, Rear Speaker Panel Ground          |
| A5ME27514     | Metal, Ground Plate                         | AACE27527     | Cable, Back Ground Stud to Hoop           |

# PARTS LIST

| PART #       | DESCRIPTION                            | PART #              | DESCRIPTION                                 |
|--------------|--|---------------------|---|
| AACE27528    | Cable, Front Ground Stud to Door Hinge | AACM3001-RTR        | Camera Assy, Rock The Rim                   |
| AACE27529    | Cable, Static Plate to Back Stud       | AAHD1900A-RTR       | SATA, Rock The Rim Game                     |
| AACE27530    | Cable, Back Stud to Front Stud         | AAMB12-HD/RTR       | Mother Board, Biostar A10n-8800e W/Sata     |
| AACE27533    | Cable, Subwoofer Cable                 | <b>LINKING KIT</b>  |   |
| AACE27539    | Cable, Power Supply To Front Stud      | AAKIT-RTR3          | Link Kit, Rock The Rim, 2-3 Games           |
| AACO1020     | Counter Assy, No Feet                  | AAKIT-RTR4          | Link Kit, Rock The Rim, 4-8 Games           |
| AALD27534    | Cable, Right Speaker Add. Light Board  | AAKIT-RTR-ADD       | Linking Parts To Increase From 3 To 8 Games |
| AALD27535    | Cable, Left Speaker Add. Light Board   | AAHD1900-RTRL       | Sata, Rock The Rim Linking Kit              |
| AALD27536    | Cable, Hoop Addressable Lights,3/Game  | AAMB12- HD/RTRLINK  | Mother Board, Biostar A10n-8800e W/Sata     |
| AALD27537    | Cable, Front Rgb Light ,Rtr, 2/Game    | <b>MARQUEE SIGN</b> |   |
| AALD27538    | Cable, Back Rgb Light ,Rtr, 2/Game     | A5EB9000            | Electrical Box                              |
| AASE27531    | Cable, Top Hoop Sensor                 | A5LK5002            | Lock, 7/8", H95 Key Code                    |
| AASE27532    | Cable, Bottom Hoop Sensor              | A5SW18000           | Switch, Rocker 20a 250v                     |
| AASP27500    | Cable Assy, Speaker, 2 Per Game        | W5HG1040            | Hinge,8-3/8"Single Bend                     |
| A5SW0020     | Subwoofer, Boss, 8", 600w              | A5CORD29            | Cord, 20' or 25' SJT                        |
| A5DE0042     | Decal, Menu/Volume Decal               | AACE1710            | Cable, 4" Door Ground Cable                 |
| A5DE0056     | Decal, Hazardous Voltage               | AACE26500           | Cable, White Lights Power                   |
| A5DE0114     | Decal, Ground Stud Symbol, 2/Game      | AACE26501           | Cable, Power Supply To Brd Pwr              |
| A5DE27500    | Decal, Control Panel                   | AACE26502           | Cable, Power Supply To Brd Gnd              |
| A5DE27501    | Decal, Cabinet Right Side              | AACE26503           | Cable, Line Filter                          |
| A5DE27502    | Decal, Cabinet Left Side               | AACE26504           | Cable, #1 Left Add Power J2                 |
| A5DE27503    | Decal, Cabinet Right Side Upper        | AACE26505           | Cable, #1 Right Add Power J8                |
| A5DE27504    | Decal, Cabinet Left Side Upper         | AACE26506           | Cable, #2 Left Add Power J3                 |
| A5DE27505    | Decal, Front Door Outer Frame          | AACE26507           | Cable, #2 Right Add Power J9                |
| A5DE27506    | Decal, Front Door Inner                | AACE26508           | Cable, #3 Left Add Power J4                 |
| A5DE27507    | Decal, Speaker Panel                   | AACE26509           | Cable, #3 Right Add Power J10               |
| WACA27506    | Acrylic, Backboard                     | AACE26510           | Cable, #4 Left Add Power J5                 |
| WACA27512    | Acrylic, Ball Guard                    | AACE26511           | Cable, #4 Right Add Power J11               |
| WACA27522    | Polycarb, Front Window, 2 Per Game     | AACE26512           | Cable, #5 Left Add Power J6                 |
| WACA27537    | Polycarb, Rear Window, 2 Per Game      | AACE26513           | Cable, #5 Right Add Power J12               |
| A5AC9101     | 12 Volt Dollar Bill Acceptor           | AACE26514           | Cable, #6 Left Add Power J7                 |
| A5FI9011     | Filter, F1700ca10, Inline              | AACE26515           | Cable, #6 Right Add Power J13               |
| AACB9600A    | PCB, Audio Amplifier Bd                | AALD26516           | Led, Outer Frame Light                      |
| A5MO5154     | Motor, Arm,10 Rpm,4069                 | AALD26517           | Led, Rtr Glow Light                         |
| AABR27500    | Ball Release Assy, Rock The Rim        | AALD26519           | Cable, Add 4 Sq Light Strand, 12/RTR Sign   |
| AAKIT-RTR-BR | Ball Release Attaching Hardware        | A5DE23021           | Decal, Electrical Warning Cover             |
| A5MO5506-RTR | Monitor, TV 55"                        | A5DE26500           | Decal, Rock The Rim Marquee                 |
| A5PS1021     | Power Supply, Gigabyte Gp-450b, 450w   | WACA26515           | Polycarb, Front Cover, (covers the decal)   |
| A5TD1        | Ticket Dispenser, Entropy              | A5FI9011            | Filter, F1700ca10, Inline                   |
| AACB15001    | PCB Assy, Bleed Resistor Board         | A5PS23000           | Power Supply, 5v Ac/Dc Converter, 300w      |
| AACB27500    | PCB, Rock The Rim, Light Board         | AACB26500           | PCB, Rock The Rim Marquee, Controller       |
| AACB5156     | PCB, Power Dist. Board                 | WACA17094           | On/Off Switch Plate                         |
| AACB5190A    | PCB, Sensor For Motor                  |                     |   |
| AACB9605-CBL | PCBA, Door Interface, W/Jumpers        |                     |   |



# TECHNICAL SUPPORT

Excellent customer service is very important to Bay Tek Entertainment! We know that keeping your games in great operating condition is important to your business. When you need us, we are here to help. You can call us for free technical assistance, and you can count on us to have parts on-hand to support your game. When you do need us, it's important that you know what to expect.  
We offer options that fit your needs.

## Electronics / Circuit Boards:

**Spare Parts** – Take matters into your own hands and purchase new spare Circuit Boards for your Bay Tek games. Many of our games share the same main-board electronics. This means you can buy one set of spare electronics to support many of your Bay Tek games. Spare boards allow you to get your game up and running the quickest and provide you a valuable troubleshooting option. Call our technicians to get recommendations for what you should keep on hand for spare parts!

## Technical Support:

“You” are the best tool for troubleshooting! Your abilities to understand the game and your skills to repair the game are invaluable to us! If you need help, you know you can call us. It's not easy to diagnose a game remotely by phone, but our technicians do a great job. They'll need your help to perform some troubleshooting steps and convey to them exactly what's happening with your game.

## Returns & Credits:

Sometimes the issue isn't what it seemed to be. If you need to return a circuit board, just give us a call to get Return Authorization. You will be credited for the cost of the board and charged only the bench fee for our processing and retesting that board.

*Note: Bench fees apply regardless of whether the repair was your choice or a recommendation from a Bay Tek Entertainment technician.*

*It's a small price to pay for troubleshooting the issues with your game.*

**[You can count on our Technical Support Team for service and support!](#)**

# WARRANTY OPTIONS

Bay Tek Entertainment warrants to the original purchaser that the game will be free of defects in workmanship and materials for a period of 12 months from the date of shipping

Bay Tek Entertainment will, without charge, repair or replace at it's option defective product or component parts upon notification to the parts/service department.

New, purchased parts have a 30 day warranty.

Any labor expended is not included in this warranty.

Warranty replacement part(s) will be shipped immediately via ground service, along with a Return Material Authorization (RMA) number for the return of defective part(s). Defective part(s) must be shipped back to Bay Tek Entertainment unless otherwise instructed.

***This warranty does not apply in the event of any misuse or abuse to the product, or as a result of any unauthorized repairs or alterations. The warranty does not apply if the serial number decal is altered, defaced, or removed from it's original position.***

Should you need your game serviced, determine the serial number from the decal on the back of the game cabinet or main board, and call **920.822.3951 Ext. 1102**

or e-mail to: [baytek.service@thevillage.bz](mailto:baytek.service@thevillage.bz)

# MARQUEE SIGN OPTION

This marquee sign will finish off the look of your multiple games.  
It will light up and flash lights to attract the ball players.

The marquee sign does not link to the games.  
It is a stand alone unit and it does not affect or influence game play at all.

| WEIGHT                |                                  |        | POWER REQUIREMENTS  |                       |                |
|-----------------------|----------------------------------|--------|---|-----------------------|----------------|
| NET WEIGHT            | 100 lbs.                         | 45 kg  | INPUT VOLTAGE RANGE   | 100 to 120 VAC        | 220 to 240 VAC |
| SHIP WEIGHT           | 157 lbs.                         | 72 kg  |   | INPUT FREQUENCY RANGE | 60 Hz          |
| MARQUEE DIMENSIONS    |                                  |        | MAX OPERATING CURRENT   |                       |                |
| WIDTH                 | 68 inches                        | 173 cm | 2 Amps @ 115 VAC / 1 Amps @ 230 VAC                           |                       |                |
| DEPTH                 | 9 inches                         | 22 cm  |   |                       |                |
| HEIGHT                | 34 inches                        | 85 cm  |   |                       |                |
| OPERATING TEMPERATURE |                                  |        | Note: Game height will be 141.5 inches tall with the marquee. |                       |                |
| FAHRENHEIT            | 45 - 80 F                        |        |   |                       |                |
| CELSIUS               | 7.2 - 26.7 C                     |        |   |                       |                |
| SHIPPING DIMENSIONS   |                                  |        |   |                       |                |
| SIGN                  | 72" L x 45" W x 20" H , 157 lbs. |        |   |                       |                |

## Quick Installation Instructions -

Refer to Marquee Sign Service Manual for more detailed instructions.

From the hardware kit, place a washer on each of the bolts and thread up into the marquee sign. Once all 8 bolts and washers have been threaded into the marquee sign, tighten with a Philips screwdriver



Bolt locations when mounted to the top of the middle of a bank of odd number games.

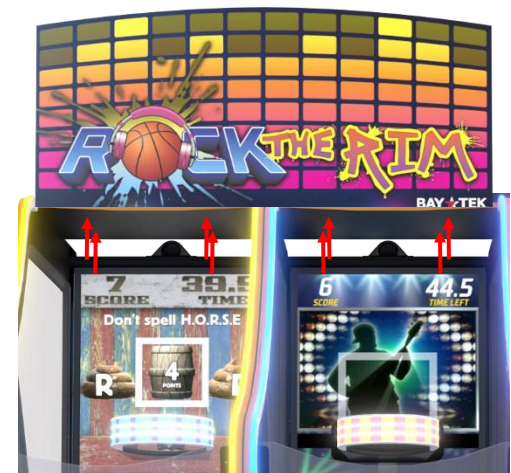

Bolt locations when mounted to the top of 2 games in bank of even number games.

# TROUBLESHOOTING GUIDE

## ***Troubleshooting Strategy***

Use common sense and a systematic method of troubleshooting to determine the exact problem, probable cause and remedy. Use the process of elimination to find the faulty component. Always check for the simple and obvious causes first such as unplugged, loose or broken wires and bad sensors, bent, pinched, stuck or jammed components.

| Problem  | Probable Cause   | Remedy   |
|--|--|--|
| <p><b>No power to the sign</b></p> <p><b>No lights on at all</b></p>   | <p>Unplugged.</p> <p>Circuit breaker tripped.</p> <p>Line Filter Faulty.</p> <p>On/ Off Switch faulty.</p> <p>Power supply shutting down because of 12 V overload.</p> <p>Faulty power supply.</p> <p>Disconnected, loose or broken wires.</p> | <p>Check wall outlet.</p> <p>Reset power strip breaker switch or building circuit breaker.</p> <p>Replace Line Filter (Part # A5F19010)</p> <p>Test 110VAC wires at switch, replace switch if needed.<br/>Part # A5SW18000</p> <p>Refer to power supply diagnostics to isolate bad component. A bad light strip would cause this.</p> <p>Refer to Power Supply Diagnostics.</p> <p>Refer to wiring diagram. Check connections and reseat cables from line filter to Power Supply. Cables # CE26503.</p> <p><b>If the supply cord is damaged, it must be replaced by a special cord or assembly available from the manufacturer or its service agent.</b><br/>Part # A5CORD29</p> |
| <p><b>General Illumination lights in Marquee are not working.</b></p> <p>These lights receive voltage directly from the power supply.</p>  | <p>Check fuses in cables.</p> <p>Ensure light strips are receiving voltage from the power supply.</p> <p>Faulty light strip.</p>   | <p>Replace fuse with same 125VAC, 7 Amp.</p> <p>Refer to wiring diagram. Check connections and reseat cables from Power Supply to the light strips.<br/>Cable #'s: CE26529, CE26528, CE26517, CE26518</p> <p>Refer to wiring diagram. Replace faulty cables.<br/>CE26517 or CE26518</p>  |
| <p><b>LED color strips are not working</b></p> <p>LED's receive voltage from Marquee Control Board.</p>  | <p>Ensure Marquee Control Board is receiving 5 VDC voltage from Power Distribution Board.</p> <p>Ensure LED cable is secure into the Marquee Control Board.</p> <p>Faulty LED</p>  | <p>Refer to wiring diagram. Check connections and reseat cables from Power Supply to Marquee Control Board<br/>Cable #'s: CE26501 &amp; CE26502</p> <p>Refer to wiring diagram. Check connections and reseat cables into the Marquee Control Board. Swap cables to verify a cable/LED issue or a socket issue on the board.</p> <p>Replace faulty LED light cable. Part # AALD26519</p>  |
| <p><b>Controller Board Issue</b></p> <div style="display: flex; align-items: center;">  <div style="margin-left: 10px;"> <p>Red LED should be flashing.</p> <p>Red power LED should be solid ON</p> </div> </div> <p><b>AACB26500 Marquee Control Board</b></p> | <p>Faulty Controller Board.</p>  | <p>If either LED indicator light is not working, check 5 Volts DC coming into board from power supply.<br/>Cable #'s: CE26533 &amp; CE26534</p> <p>If 5 volt DC is ok, then replace controller board Part # AACB26500</p>  |

# MARQUEE SIGN WIRING DIAGRAM

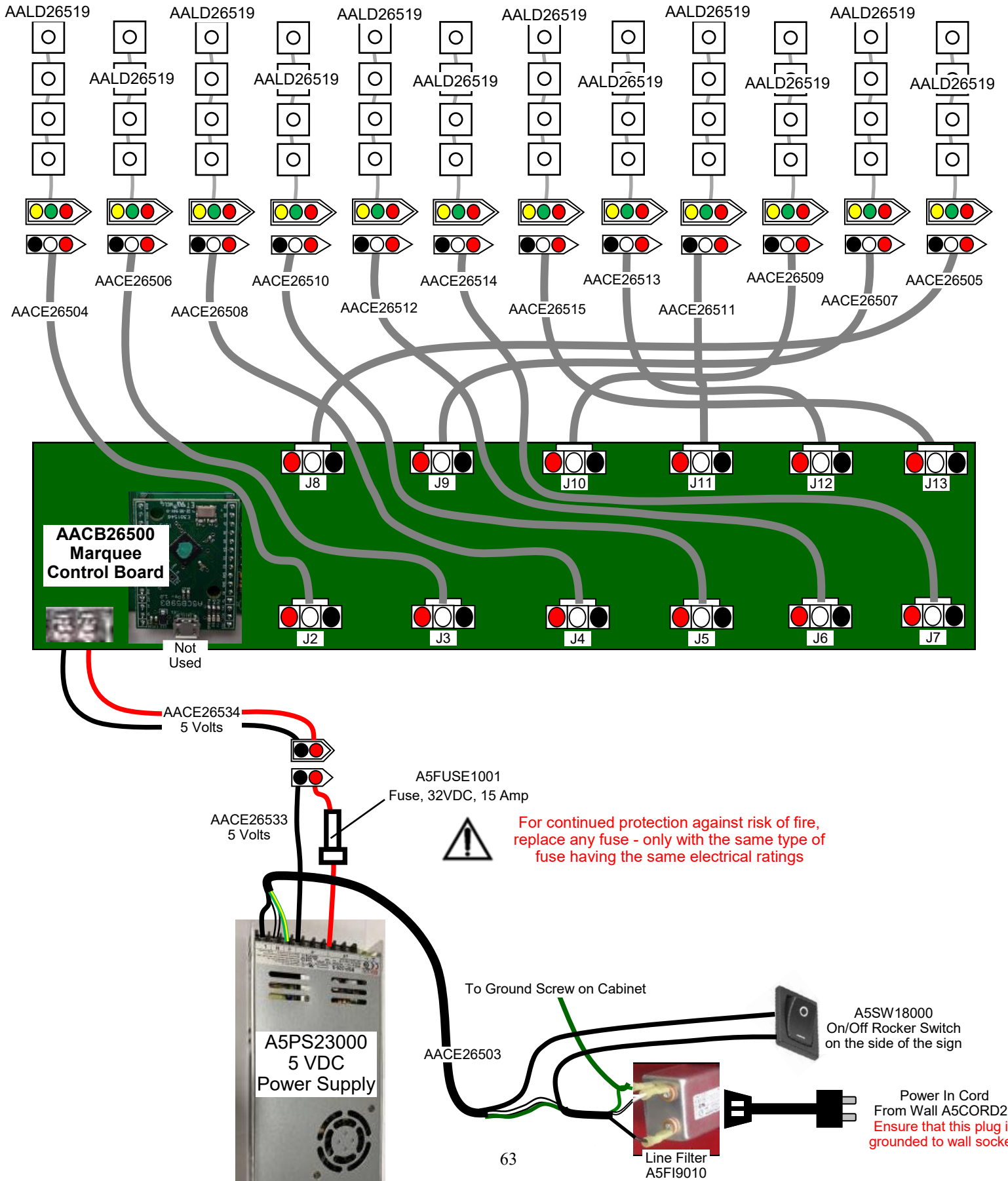

# MARQUEE SIGN WIRING DIAGRAM

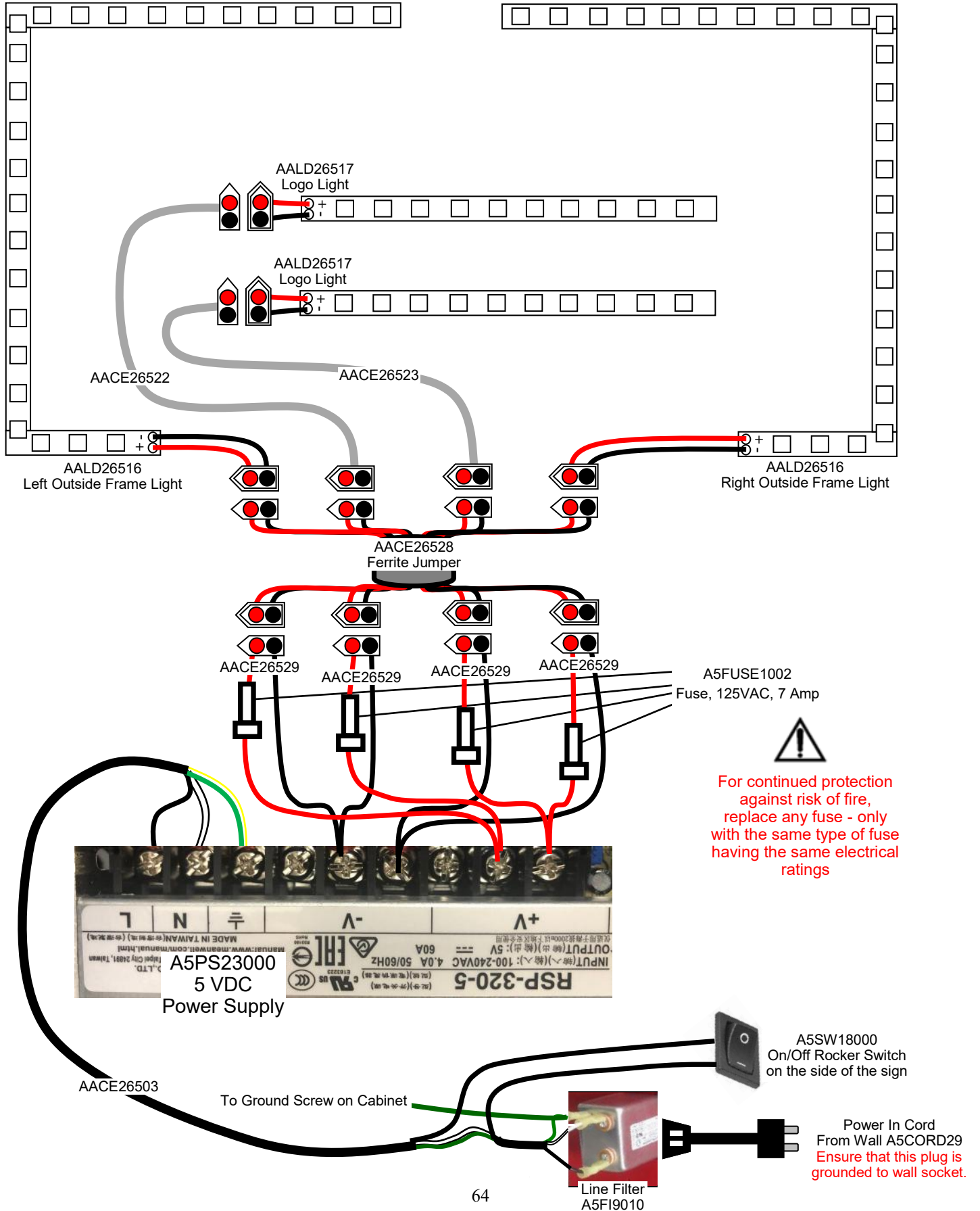

# POWER SUPPLY DIAGNOSTICS

## Minimize load on power supply and isolate short

Unplug the all 4 of the CE26529 cables going to the LED lights.

This will leave the power supply and Marquee Control Board (which control the inside lights) plugged in together.

If the inside lights now turn on:

Plug in one CE26529 cable at a time to power supply to locate short.

If the power supply shuts down after you plug in a specific cable, that cable is faulty.

If the inside lights still do not turn on:

Unscrew the CE26533 cable from the power supply.

If the power supply does not turn on, replace the power supply. Part # A5PS23000

If the power supply turns on, reattach the CE26533 cable and unplug all the output light cables from the Marquee Control Board.

If the power supply does not turn on, replace the Marquee Control Board. Part # AACB26500

If the power supply does turn on, plug in one of the output cables at a time to locate the bad cable.

If the power supply shuts down after you plug in a specific cable, that cable is faulty.

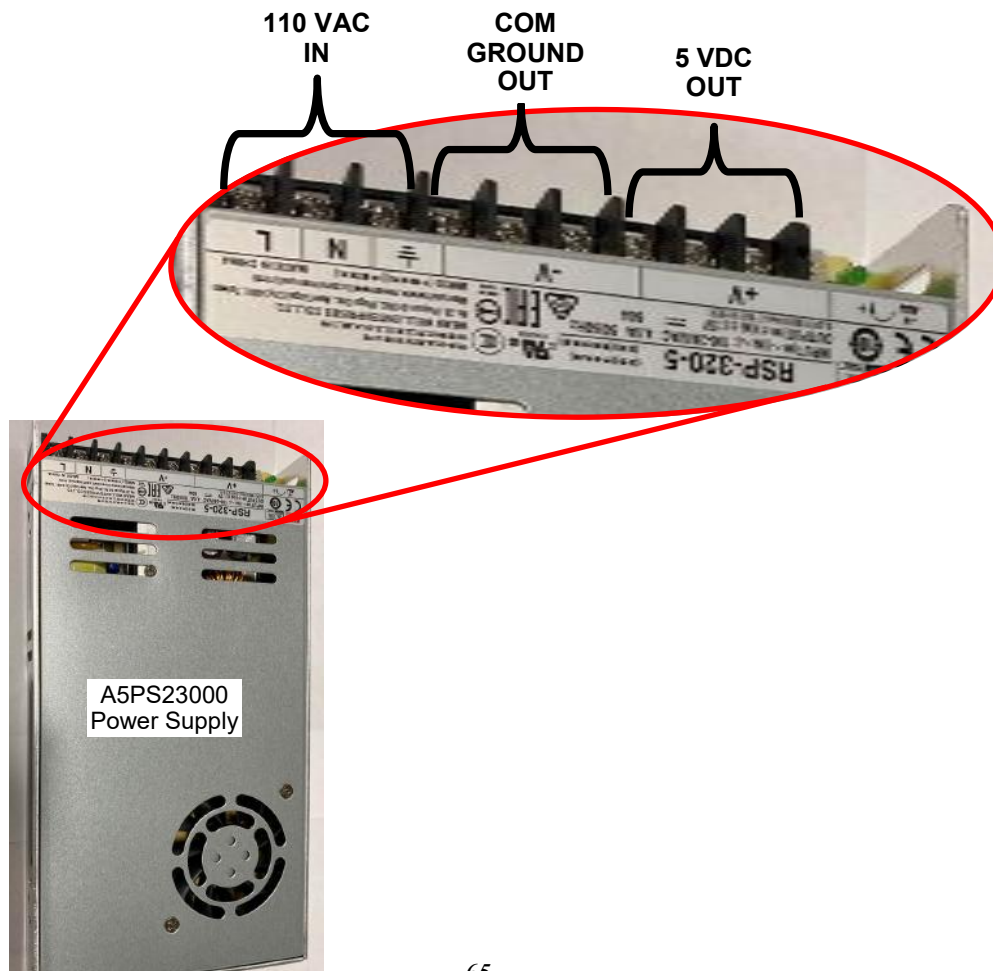

# PARTS PICTURES



A5EB9000



A5KIT-RTRSIGN



A5LK5002



A5SW18000



W5HG1040



A5CORD29



AACE1710



AACE26503



AACE26504



AACE26505



AACE26506



AACE26507



AACE26508



AACE26509



AACE26510



AACE26511



AACE26512



AACE26513



AACE26514



AACE26515



AACE26522



AACE26523



AACE26528



AACE26529



AACE26533



AACE26534



AALD26516



AALD26517

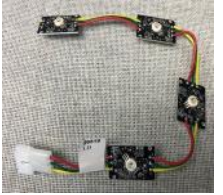

AALD26519



A5DE23021



A5FI9011



A5PS23000



AACB26500



WACA17094

A5DE26500 Control Panel Decal

WACA26515 Clear Plexi covering Decal



# LINKING KIT OPTION



This linking kit will allow players to play head-to-head across up to 8 games. It can also be connected to the internet to allow high scores to be posted worldwide.

| POWER REQUIREMENTS                      |                |                |
|---|----------------|----------------|
| INPUT VOLTAGE RANGE                     | 100 to 120 VAC | 220 to 240 VAC |
| INPUT FREQUENCY RANGE                   | 60 Hz          | 50 Hz          |
| MAX OPERATING CURRENT                   |                |                |
| 0.6 Amps @ 115 VAC / 0.6 Amps @ 230 VAC |                |                |

## Quick Installation Instructions -

Refer to Linking Kit Service Manual for more detailed instructions.

Install the preassembled board into the right side of any Rock the Rim game.

Plug a network cable from each of the games into the router on the link kit.



# WIRING DIAGRAM

8 Indicator LED's will light up when a game is connected.  
 Green = Connected  
 Red = Disconnected  
 Orange = No longer connected

Green Power LED Flashes when the motherboard is communicating

Note: If your motherboard looks different, it is a MB13 Motherboard. Refer to MB13 Motherboard Section for more detail.

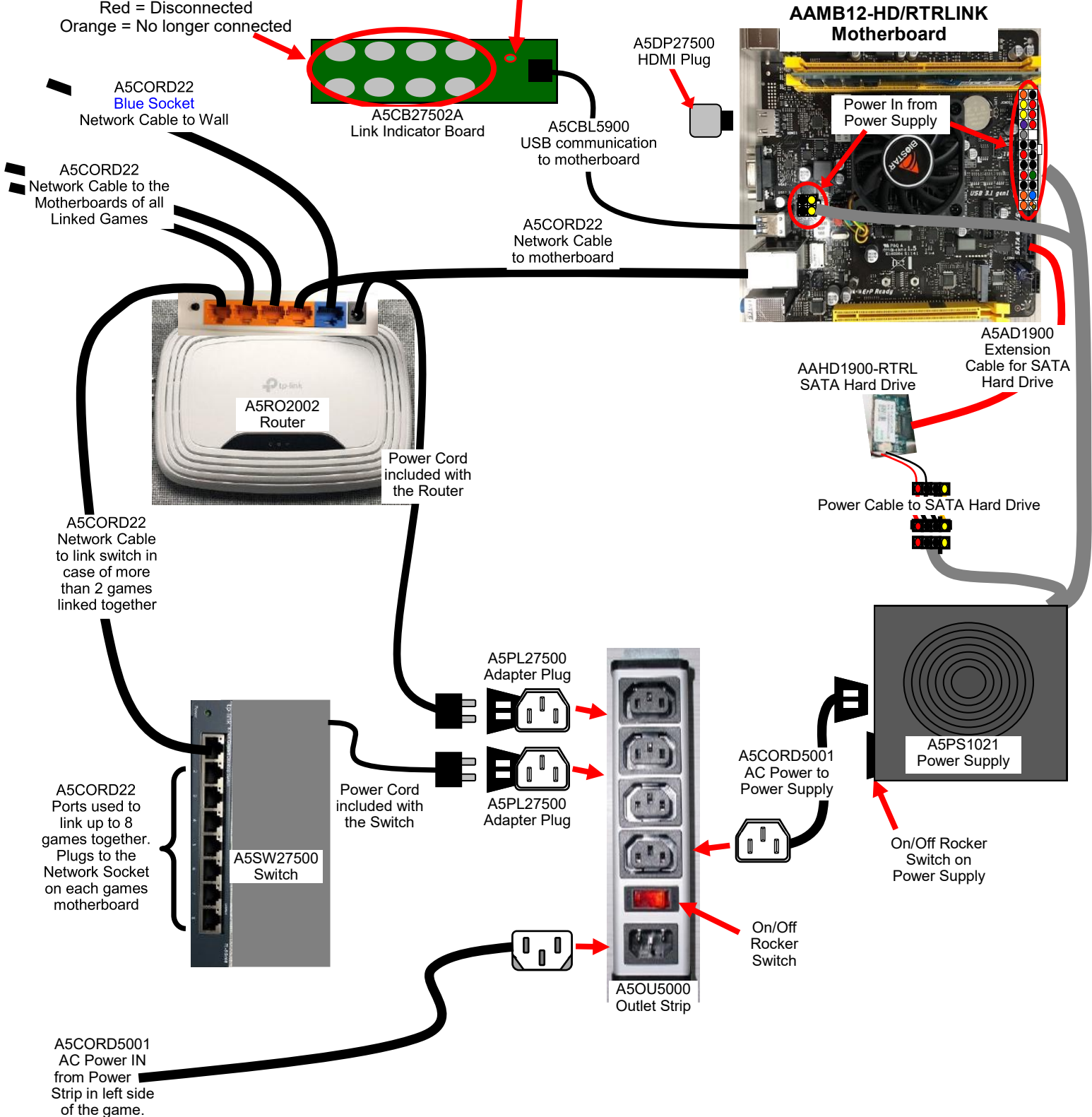

**Boards are located inside the front door of one of the linked games. They should be mounted to the right side of the game.**

# PARTS PICTURES



A5BK999



A5CBL5900



A5CORD22



A5CORD5001



A5DP27500



A5GU12



A5SC12



A5OU5000



A5PL27500



A5PS1021



A5RO2002



A5SW27500

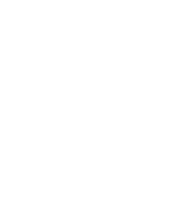

A5CB27502A



AACAI320-10



A5AD1900



AAHD1900-RTRL



AAMB12-HD/RTRLINK



AAHD0032-RTRLINK



AAMB13-HD/RTRLINK

# PARTS LIST

| PART #     | DESCRIPTION                     | PART #            | DESCRIPTION                           |
|------------|---------------------------------|-------------------|---------------------------------------|
| A5BK999    | Power Supply Mounting Bracket   | A5PS1021          | Power Supply, 450w                    |
| A5CBL5900  | USB, Male A To Male Micro       | A5RO2002          | Router                                |
| A5CORD22   | Cord, 15', RJ45 to RJ45         | A5SW27500         | Switch, 8 Port                        |
| A5CORD5001 | Cord, Extension, 2', C14 To C13 | A5CB27502A        | Link Kit Linked Indicator Board       |
| A5DP27500  | HDMI Dummy Plug                 | AACAI320-10       | Capacitor, Power On                   |
| A5GU12     | Fan Guard                       | A5AD1900          | Adapter Extensions for SATA           |
| A5SC12     | Screw for Fan Guard             | AAHD1900-RTRL     | Rock The Rim Linking Kit SATA Drive   |
| A5OU5000   | Outlet Strip                    | AAMB12-HD/RTRLINK | Mother Board, MB12, Rock the Rim Link |
| A5PL27500  | Plug, Adapter for Power Strip   | AAHD0032-RTRLINK  | Rock the Rim Linking Kit M.2 Drive    |
|            |                                 | AAMB13-HD/RTRLINK | Motherboard, MB13, Rock the Rim Link  |