



# RING OF FIRE

PLACE SERIAL NUMBER LABEL HERE



# FACTORY CONTACT INFORMATION



BAY TEK GAMES INC.  
Pulaski Industrial Park  
1077 East. Glenbrook Drive  
Pulaski, WI 54162 USA

## JOIN OUR SERVICE FIRST NETWORK!

This free service is intended to keep you up to date on the latest game information, early notification of parts specials, pertinent technical bulletins, updates on retro fit parts, software upgrades, and much more.

Log on to: **[www.baytekgames.com/parts](http://www.baytekgames.com/parts)**  
then click on the Parts N' Service tab to jump straight to this game's parts page!

### SALES

P: 920.822.3951

F: 920.822.8936

E: [sales@baytekgames.com](mailto:sales@baytekgames.com)

### PARTS

P: 920.822.3951 X 1101

F: 920.822.1496

E: [parts@baytekgames.com](mailto:parts@baytekgames.com)

### SERVICE

P: 920.822.3951 X 1102

F: 920.822.1496

E: [service@baytekgames.com](mailto:service@baytekgames.com)

MON - FRI  
8 AM - 5 PM C.S.T.

All games are proudly manufactured at our factory in Pulaski, Wisconsin, USA

## GAME INSPECTION

Inspect the game for any damaged, loose, or missing parts. If damage is found, please contact your freight carrier first. Then, contact Bay Tek Games' Service Department at 920.822.3951 or e-mail them at [service@baytekgames.com](mailto:service@baytekgames.com) for further assistance.

# TABLE OF CONTENTS

FACTORY CONTACT INFORMATION .....	2
WELCOME TO: RING OF FIRE .....	4
HOW TO PLAY .....	5
SPECIFICATIONS .....	6
SAFETY PRECAUTIONS .....	6
DIP SWITCH SETTINGS .....	7
QUICK SET UP GUIDE .....	8-9
MAIN MENU FUNCTIONS .....	10
GAME SETUP MENU .....	11
TICKET PATTERNS .....	11
DIAGNOSTICS MENU .....	12
STATISTICS MENU .....	12
TROUBLESHOOTING GUIDE .....	13-20
UPDATING SOFTWARE .....	21
WIRING DIAGRAMS .....	22-27
PARTS LIST .....	28
PARTS PICTURES .....	29
DECAL IDENTIFICATION .....	30
MAINTENANCE LOG .....	31
TECHNICAL SUPPORT .....	32
WARRANTY .....	33

# WELCOME TO: FIREBALL: Ring of Fire!

## Congratulations on your Ring of Fire purchase!

This revolutionary alley bowler will pump up the excitement in your game room with its fun graphics and sounds, and the ability for up to four players to compete against each other! The 22" flat screen monitor provides a friendly user interface complete with hot graphics and original gameplay!

Please take a moment to read through this manual and be sure to contact our factory if you have any questions, or would like some more information.

Thank you for your purchase! Your business is important to us and we hope you enjoy this game as much as we do!

*Your Friends at Bay Tek Games*



## GAME INSPECTION

Inspect the game for any damaged, loose, or missing parts.

If damage is found, please contact your freight carrier first.

Then, contact Bay Tek Games' Service Department at 920.822.3951 or e-mail them at [service@baytekgames.com](mailto:service@baytekgames.com) for further assistance.

# HOW TO PLAY

Step right up and choose 1-4 players by inserting extra credits.



Roll all nine balls into the targets. See frame-by-frame scores and compare with the other players. Aim for the lighted ring for Double Points!



Grab your tickets and play again!













# GAME SPECIFICATIONS

WEIGHT	
NET WEIGHT	450 LBS
SHIP WEIGHT	550 LBS
DIMENSIONS	
WIDTH	30"
DEPTH	114"
HEIGHT	80"
OPERATING TEMPERATURE	
FAHRENHEIT	70-80
CELSIUS	21-27

POWER REQUIREMENTS			
INPUT VOLTAGE RANGE	100 to 120 VAC	/	220 to 240 VAC
INPUT FREQUENCY RANGE	50 HZ	/	60 HZ

MAX START UP CURRENT	OPERATING CURRENT
2.6 AMPS @ 115 VAC	1.5 AMPS @ 115 VAC
1.3 AMPS @ 230 VAC	.75 AMPS @ 230 VAC

# SAFETY PRECAUTIONS

 <b>DANGER</b> 
DO NOT perform repairs or maintenance on this game with the power ON. Unplug the unit from the wall outlet or shut off the power strip located inside the cabinet.
 <b>WARNING</b> 
Use of flammable substances can cause sever burns or serious injury. Always use NON-FLAMMABLE solvents for cleaning. DO NOT use gasoline kerosene or thinners.
 <b>CAUTION</b> 
Lifting heavy objects can cause back, neck or other injuries. Be sure adequate lifting and moving devices are available when unloading, unpacking and moving this game.
 <b>ATTENTION</b> 
Be sure the electrical power matches the game requirements. See the serial number located on the back of the game cabinet. Always plug into a grounded circuit. If the supply cord is damaged, it must be replaced by an approved cord or assembly provided by the manufacturer.
 <b>IN CASE OF EMERGENCY</b> 
UNPLUG THE POWER CORD. The power cord must be accesible at all times in case of an emergency.

# DIP SWITCH SETTINGS

The dip switch bank is located on the mainboard, inside the front door of the game.

\*factory default settings are highlighted below

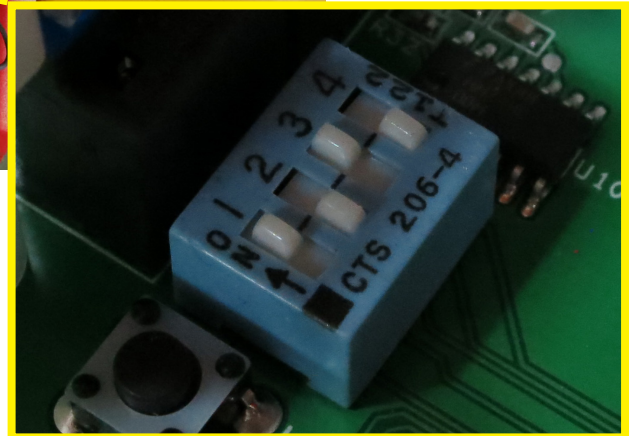

THE DIPS MUST BE SET AS SHOWN FOR THE GAME TO FUNCTION PROPERLY

SWITCH	1	2	3	4
ON				
OFF				

# QUICK SET UP GUIDE

Place the target cabinet near its final location.

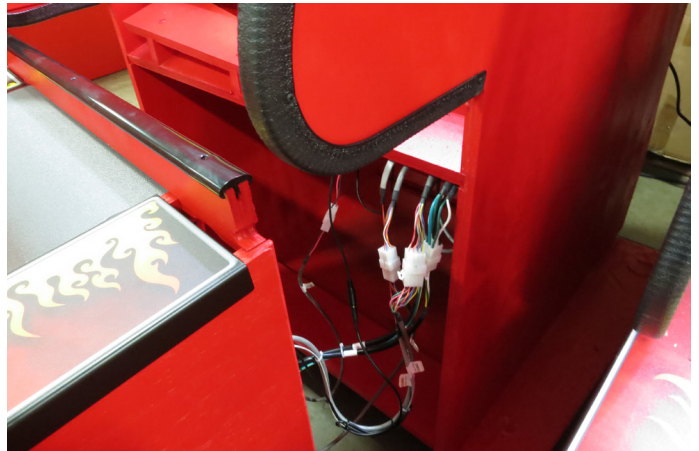

Push the ramp cabinet to about a foot from the target cabinet, and plug in the six sets of cables as shown.

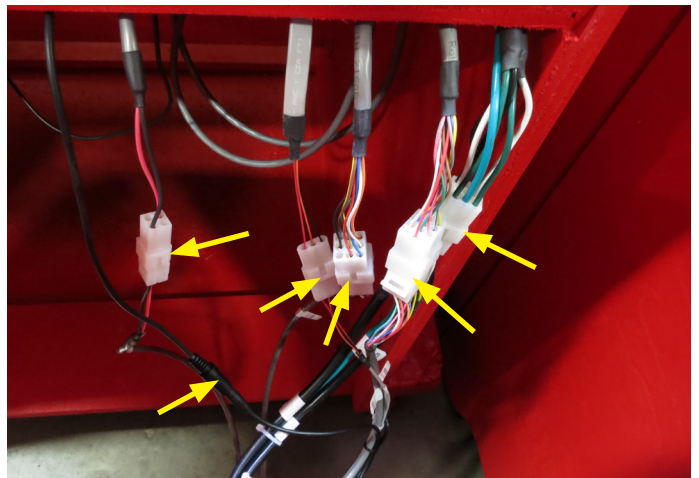

Slide the ramp cabinet flush to the target cabinet.



# QUICK SET UP GUIDE

Drop the 9 balls (found in a box inside the target cabinet) into the playfield.



Plug the power cable into the back of the target cabinet and into a standard 110V electrical outlet.



Open the front doors of the ramp and switch the power strip to "on".



**Congratulations! You're Ready to Roll!**

# MAIN MENU FUNCTIONS

The menu access buttons are located inside the front door of the ramp.

Press the **MENU/SELECT** button to enter the Main Menu.

Move through the menu with the **SCROLL** button.

Make your selection with the **MENU/SELECT** button.

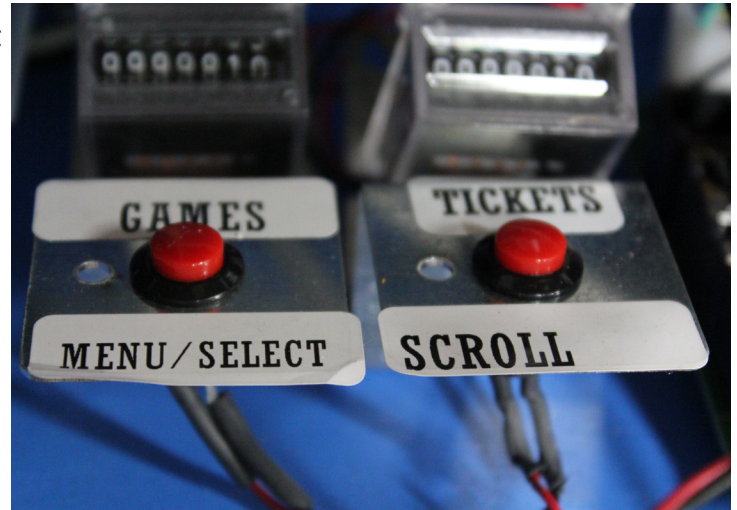

## ***RING OF FIRE main menu***

***Game SETUP  
DIAGNOSTICS menu  
STATS menu  
EXIT menu***

***SOFTWARE VERSION = 1.0.1  
COMPILE DATE: OCT 20 2012  
MINIGEN SOFTWARE VERSION = 1.51***

# GAME SETUP MENU

## RING OF FIRE Game Setup Menu

**CREDITS/GAME**

**TICKET PATTERN**

**ATTRACT VOLUME**

**GAME VOLUME**

**EXIT MENU**

**2**  
**TABLE 11**  
**0**  
**20**

<b>Credits/ Game</b>	0	1	2	3	4	5	6	7	8					
<b>Ticket Pattern</b> (see below)	1A				1B				2					
<b>Fixed Ticket Payout</b>	DISABLED			1 TICKET				TO		40 TICKETS				
<b>Multi-Player Option*</b>	ENABLED						DISABLED							
<b>Attract Volume</b>	0	1	2	3	4	5	6	7	8	9				
<b>Game Volume</b>	0	1	2	3	4	5	6	7	8	9				

# TICKET PATTERNS

TICKET PATTERN	GAME SCORE (in thousands)													
	0	10	15	20	25	30	35	40	45	50	60	70	80	90
	-	-	-	-	-	-	-	-	-	-	-	-	-	+
	TICKETS													
<b>1A</b>	8	16	20	24	28	36	40	50	60	70	100	150	200	1000
<b>1B</b>	8	16	20	24	28	36	40	50	60	70	100	150	200	500
<b>2</b>	8	10	12	14	16	18	20	22	24	26	28	30	50	250
<b>3A</b>	8	14	16	20	24	28	30	40	44	50	75	100	150	500
<b>3B</b>	8	14	16	20	24	28	30	40	44	50	75	100	150	250

# DIAGNOSTICS MENU

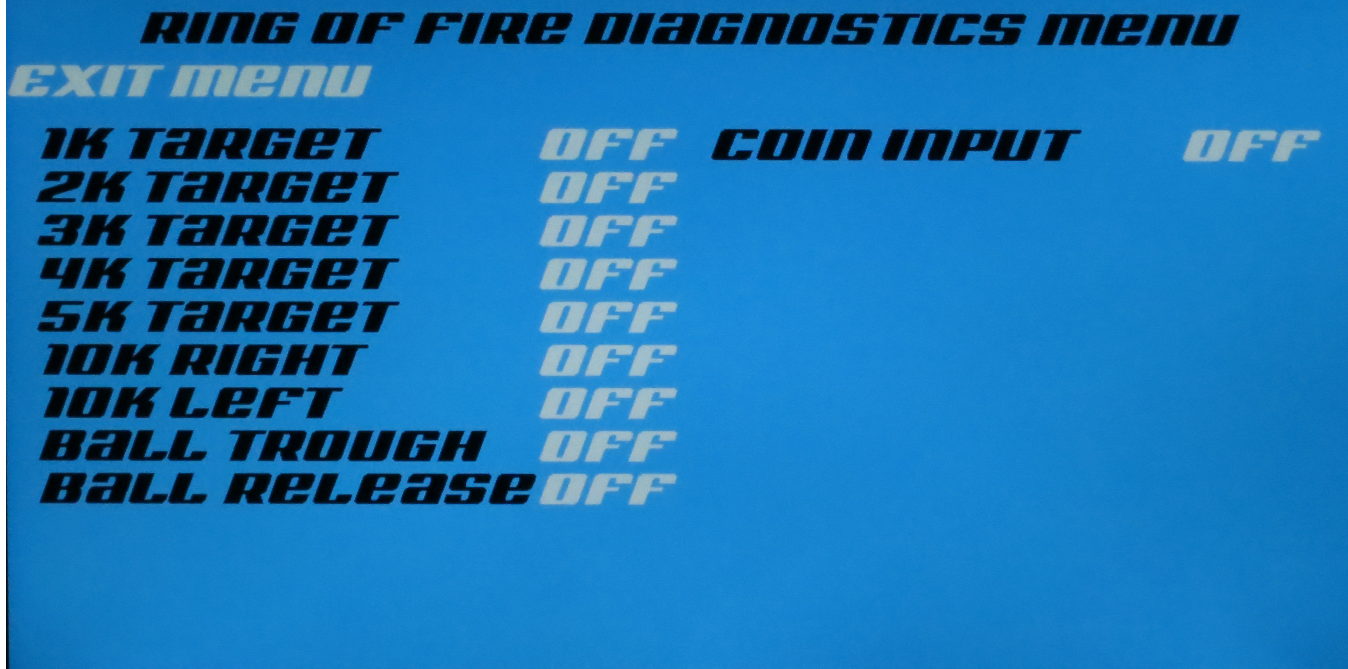



This diagnostic mode will help in determining if all sensors and inputs are functioning correctly. Activating any input listed here should turn the display from OFF to ON. The game will automatically alternate lighting the targets in numerical order while diagnostic mode is on.

# STATS MENU



# TROUBLESHOOTING GUIDE

Problem	Probable Cause	Remedy
<p>No power to the game.</p> 	<p>Unplugged.</p> <p>Connector loose between head and ramp</p> <p>Power strip turned off, or plugs unplugged.</p> <p>Circuit breaker tripped.</p> <p>Bad power supply.</p>	<p>Check wall outlet to line filter in back of game. (A5FI9010)</p> <p>Check connection between head and ramp.</p> <p>Check rocker switch on power strip. Ensure power cords are pushed up into power strip securely.</p> <p>Reset power strip breaker switch or building circuit breaker. Attempt to determine cause.</p> <p>Refer to Monitor/Motherboard Power Supply Diagnostics</p> 
<p>Bill Acceptor on, but everything else off.</p> <p>(Power Supply not ON)</p>	<p>Power supply unplugged.</p> <p>Rocker Switch on power supply is Off.</p> <p>Power supply shutting down because of 12 V overload.</p> <p>Faulty power supply.</p>	<p>Insure unit is plugged into power strip.</p> <p>Make sure rocker switch is set ON.</p> <p>See power supply diagnostics to isolate bad component. A bad motor or 12 volt short would cause this.</p> <p>Refer to Monitor/Motherboard Power Supply Diagnostics section.</p>
<p>Chase lights on ramp do not flash.</p>	<p>LED strip faulty</p> <p>Faulty Cable</p> <p>Faulty Main Board</p>	<p>Unplug one strip from main board and see if both strips are bad or just one. Remove plastic cover and examine LED strip.</p> <p>Check cables from LED strips to main board. (AACL2100)</p> <p>Replace main board. (AANEWGEN-PJ)</p>
<p>LED cabinet lighting not working.</p>	<p>LED's to light up playfield plug into power supply behind monitor.</p>	<p>Check for proper connection from power supply to power supply. Check continuity. (AACE2033, AACE2032, A5PS1008)</p> <p>Refer to AC Power &amp; 12 Volt Power Wiring section.</p>
<p>LED's lighting up playfield rings not working.</p>	<p>LED's in rings will light up when hole is scored.</p> <p>Faulty wire or connection.</p> <p>Faulty LED light strip.</p> <p>Faulty main board.</p>	<p>Ensure hole is scoring, if not - refer to Game Scores Wrong Section.</p> <p>Check for proper connection from LED's to main board. Check continuity. Check for damaged connector between head and ramp game pieces. Refer to Counters, Rack Sensor and LED's Wiring section. (AACE2041, AACE2042, AACE2036, AACE2035)</p> <p>Replace LED light strip. (AACE2041 or AACE2042)</p> <p>Replace main board. (AANEWGEN1-PJ)</p>

# TROUBLESHOOTING GUIDE



Problem	Probable Cause	Remedy
Dollar Bill Acceptor not functioning.	<p>Ensure bill acceptor has 110 Volts AC. <b>Note: Game will allow 12 Volt DBA to be installed.</b></p> <p>Dirt or debris in acceptor slot.</p> <p>Ensure acceptor dipswitch is set to “always enable”</p> <p>Pinched, broken, or disconnected wiring.</p> <p>Check coin switch for function.</p> <p>Bill acceptor problem.</p>	<p>Acceptor should cycle stacker at game power up. If not, check cable connections to power strip. <b>Caution – 110 Volts AC</b></p> <p>Clean with bill reader cleaning card. (A5CC9000)</p> <p>There are dips on side of acceptor. Set to “always enable” (not harness enable)</p> <p>Check wiring from bill acceptor to main board. Repair or replace wiring harness. (AACE2012)</p> <p>If coin switch does not work—refer to “Game does not coin up” troubleshooting.</p> <p>Refer to troubleshooting section of dollar bill acceptor manual included with this game or the diagnostics label of the back of the unit.</p>
No Audio	<p>Volume too low.</p> <p>Loose wire.</p> <p>Faulty motherboard</p> <p>Faulty main Board</p>	<p>Increase the volume by pressing Menu button, scroll to “Game Volume” and adjust. </p> <p>Check audio cable connections from motherboard to main board to speakers.</p> <p>Check audio cable connections from speaker(AACE8811), cable(AACE206), main circuit board(AANEWGEN1-PJ), cable(A5CEAU010), motherboard (AAMB7)</p> <p>Replace Motherboard. (AAMB7) Motherboard creates sound. Cable can be removed from motherboard to MP3 player to test for sound amplification. If the MP3 player works, then motherboard is faulty.</p> <p>Replace Main Board. (AANEWGEN1-PJ) Main board amplifies sound from motherboard.</p>
<b>Low tickets</b> displays on monitor.	<p>Stack of tickets not resting properly on either of the low ticket switches</p> <p>Faulty switch.</p> <p>Faulty wire or connection.</p> <p>Faulty main board.</p>	<p>Adjust stack of tickets so they hold both the switch actuators down.</p> <p>Replace low ticket switch. (AASW200)</p> <p>Check for proper connection from switch to main board. Check continuity. (AACE2025)</p> <p>Replace main board. (AANEWGEN1-PJ)</p>



# TROUBLESHOOTING GUIDE

PROBLEM	PROBABLE CAUSE	REMEDY
Tickets do not dispense.	<p>Ticket tray empty due to faulty low ticket switch or broken/ loose wires. Switch stuck or switch wire bent out of position.</p> <p>Faulty cable to dispenser.</p> <p>Dirty opto-sensor or paper dust buildup in ticket dispenser</p> <p>Notch on tickets too shallow.</p> <p>Ticket dispenser faulty.</p> <p>Main circuit board malfunction.</p>	<p>Fill ticket tray. Replace low ticket switch(AASW200). Repair wiring. Clean ticket tray of dirt, loose tickets or debris. Bend switch wire to correct position under tickets.</p> <p>Check wiring continuity from dispenser to main board (AACE2025) Check for pinched, broken or disconnected wires. Replace as necessary.</p> <p>Clean with compressed air and if necessary wipe sensor with isopropyl alcohol on a cotton swab.</p> <p>Flip tickets and load upside-down to have large cut notch toward opto sensor.</p> <p>Replace dispenser with spare working dispenser (A5TD1)</p> <p>Replace main board if possible to isolate the problem to the main circuit board. (AANEWGEN1-PJ)</p>
Wrong number of tickets dispensed.	<p>Ticket Pattern set wrong.</p> <p>Dirty opto-sensor on ticket dispenser.</p> <p>Many tickets in memory. If ticket meter is counting the tickets coming out, then reset game.</p> <p>Notch on tickets cut too shallow.</p> <p>Faulty ticket dispenser.</p> <p>Main circuit board malfunction.</p>	<p>Enter menu and cycle to Setup Menu. Verify correct settings for Ticket Pattern</p> <div style="text-align: right; margin-bottom: 10px;">  </div> <p>Clean with compressed air or wipe with isopropyl alcohol on a cotton swab.</p> <p>Turn game off, wait 10 seconds, and turn game back on.</p> <p>Flip tickets and load upside-down to have large cut notch toward opto sensor.</p> <p>Replace with spare working dispenser (A5TD1).</p> <p>Swap cable from one output on main board to the other to verify cable/dispenser problem or faulty main board. (AANEWGEN1-PJ)</p>
Menu buttons do not work.	<p>Stuck pushbutton.</p> <p>Cable problem.</p> <p>Faulty pushbutton.</p>	<p>Inspect pushbutton to make sure it is not stuck. Check continuity on connector.</p> <p>Check cable from pushbutton to main board. (AAPB2700 &amp; AACE2018)</p> <p>Replace pushbutton. (AAPB2700)</p>

# TROUBLESHOOTING GUIDE

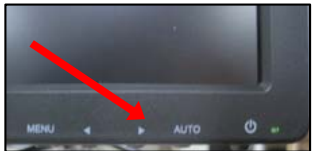
Problem	Probable Cause	Remedy
<p>Balls are not released.</p> 	<p>Ball release solenoid sticking.</p> <p>AC Driver Board defective.</p> 	<p>Check for free movement of assembly. Check for 110 VAC pulse at solenoid.</p> <p>Check for green LED pulse on driver board If pulse ok: Replace fuse located in small box on AC driver board. (A5FUSE3) Replace AC Driver board. (AABD5029) If no pulse, check wires from AC driver to main board. Replace main board. (AANEWGEN1-PJ)</p>
<p>Too many balls are released.</p>	<p>Sensor at ball release blocked, dirty, or faulty.</p> <p>Pinched, broken, or disconnected wiring.</p>	<p>Clean sensor. Green LED should only come on when blocked. Replace if needed. (AACB2203)</p> <p>Check connections from sensor board to main board. Check continuity on wires.</p>
<p>Not enough balls are released.</p> <p>Game is waiting for player to throw balls and there are none left in track.</p>	<p>Ball count opto sensor is defective.</p>  <p>Opto sensor at ball release is defective.</p>	<p>If this sensor misses a ball, the game will continue waiting until game time-outs. Replace sensor. (AACB2203)</p> <p>If this sensor “sees” 2 balls instead of one. Replace sensor. (AACB2203)</p>
<p>Meters do not work.</p> <p><b>Game counter clicks at start of each game.</b></p> <p><b>Ticket counter clicks as tickets come out of game.</b></p>	<p>The 2 wires crimped together may be faulty</p> <p>Pinched, broken, or disconnected wiring</p> <p>Main board faulty</p>	<p>Inspect crimp to ensure good connection.</p> <p>Check connections from counters to main board. Check continuity on wires. (AACO1000, AACE2035)</p> <p>Replace main board</p>
<p>Monitor problems</p> <p>Blurry Monitor Too bright, or dim.</p>	<p>Remove marquee in front of monitor.</p> <p>Press the far left button—black bar will appear on display. Press the far left button again to select Auto Adjustment. This may take a few seconds.</p> <p>Verify that the screen looks good and image is centered.</p>	

# TROUBLESHOOTING GUIDE

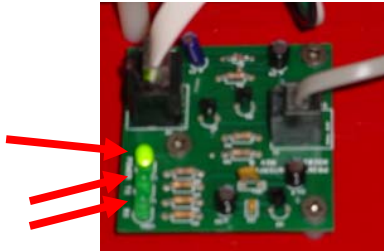
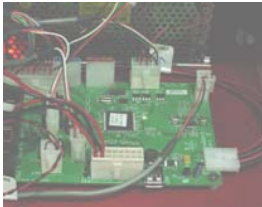
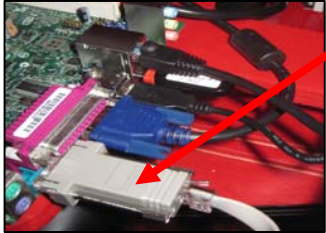
Problem	Probable Cause	Remedy
<p>Game scores wrong.</p>	<p>Game starts with a score already on display or scores double points.</p>	<p>Opto is defective under score hole. Enter menu, go to Diagnostics Menu to check sensors. Replace defective opto. (AACB2203)</p>
<p><b>Game does not coin up.</b></p> <p>Game <b>has</b> audio track "clinking" sound from speakers when coin switch triggered.</p>	<p>Main Board and wiring to coin switch OK.</p> <p>Check green LED's on Serial Interface board. "Power" solid ON</p> <p>"TX" &amp; "RX" blinking very fast.</p>	
	<p><b>If "Power" is not solid ON</b></p> <p>Ensure AACE2022 cable is plugged into blue "IN" socket on main board. (J16) Replace if needed.</p> <p>Replace Serial Interface board. (AACB2204)</p> <p>Replace main board. (AANEWGEN1-PJ)</p> 	<p><b>If "TX" &amp; "RX" are not blinking very fast</b> Communication to Motherboard faulty. (Motherboard is located behind monitor.)</p> <p>Check AACE2011 cable from Serial Interface board to coupler between head and ramp (A5CO2002) up to motherboard behind monitor. Check adaptor (A5CN1031)</p>  <p>Refer to: Monitor/Motherboard Power Supply Diagnostics</p>
<p><b>Game does not coin up.</b></p> <p>Game <b>does not have</b> audio track "clinking" sound from speakers when coin switch triggered.</p>	<p>One or both coin switches faulty.</p> <p>Pinched, broken, or disconnected wiring.</p> <p>Faulty Main Board</p>	<p>If one is held "closed" - the other will not work</p> <p>Check connections from coin switches to "Coin" connector on main board. Check continuity on wires. (AACBL4A-DOOR &amp; AACE2004)</p> <p>Replace main board. (AANEWGEN1-PJ)</p>

# TROUBLESHOOTING GUIDE

Problem	Probable Cause	Remedy
<b>Monitor not working.</b>	<p>Monitor says NO SIGNAL for 5 seconds after power up. Then dark.</p>	<p>Small 12 Volt power connector unplugged on motherboard.</p> <p>Monitor VGA cable unplugged.</p> <p>Large power connector unplugged on Motherboard</p> <p>Faulty or loose RAM</p> <p>Refer to Monitor/Motherboard Power Supply Diagnostics Section to check for faulty power supply or motherboard.</p> <div style="text-align: right; margin-top: 10px;">  </div>
Power down, wait 10 seconds and power up again.	<p>Monitor has nothing at all on power up.</p>	<p>Power cable unplugged from monitor.</p> <p>Faulty monitor.</p> <p>Ensure power is plugged into back of monitor, down to power strip.</p> <p>Replace monitor. (A5MO2200)</p>
Error on screen at power up.	<p>Display stops at "No bootable device -- insert boot disk and press any key"</p>	<p>Flashdrive unplugged from board or faulty. Re-seat and try power on to game again.</p> <p>Replace USB software stick.</p>
Re-Boot game to see if problem still exists.	<p>Display shows "Puppy Video Wizard" or "Xorg"</p>	<p>Game is not recognizing monitor. Ensure VGA cable is secure to I/O board.</p> <p>Connect keyboard to motherboard and press enter and enter again on default settings.</p>
Lights under Red & Blue Gameplay Pushbutton do not come on.	<p>Burnt out LED bulb.</p> <p>Faulty Cable</p>	<p>Replace switch/bulb assy(A5PB2001, A5PB2002)</p> <p>Check cables from pushbutton to main board. (AAACE2030, AAACE2003, AAACE2035)</p> <p>Refer to Board Communication, Player Change Buttons Wiring Diagram</p>
Faulty Main Board	<p>Faulty Main Board</p>	<p>Replace main board. (AANEWGEN-PJ)</p>
Lights under Red & Blue Gameplay Pushbutton stays on.	<p>Surface mounted transistor blown on main board.</p>	<p>Replace main board. (AANEWGEN-PJ)</p>
Red & Blue Gameplay Pushbuttons do not work.	<p>Pushbutton itself is broken or stuck down</p> <p>Faulty Cable</p>	<p>Clean switch and ensure it moves freely. Replace if needed. (A5PB2001, A5PB2002)</p> <p>Check cables from pushbutton to main board. (AAACE2030, AAACE2003, AAACE235)</p> <p>Refer to Board Communication, Player Change Buttons Wiring Diagram</p>
Faulty Main Board	<p>Faulty Main Board</p>	<p>Replace main board. (AANEWGEN-PJ)</p>

# DOLLAR BILL ACCEPTOR DIAGNOSTICS

**Note: There are many different models and brands of Bill Acceptors that are used on redemption games. Your Bill Acceptor may differ from the unit shown.**

First determine if Bill Acceptor has power:

Turn game ON—The bill acceptor should make noise as stacker cycles and green lights on outside bezel should flash.

If NO power:

Due to the different models and brands of Bill Acceptors that are used: Examine Bill Acceptor and determine if acceptor is 12 Volt DC or 110 VAC Use meter to measure voltage at cable going into Bill Acceptor.



If power is OK:

Clean Bill Acceptor path to make sure there is nothing jamming unit.

Enter DBA Diagnostics Mode -

**Important—Do not hold button down too long or Bill Acceptor will enter programming mode.**

If accidentally entered programming mode by mistake—Unplug game and plug back in.

To enter Diagnostic Mode, press and hold the Diagnostic Button on the back left corner of the DBA for **1-3 seconds.**

The lights above the bill slot will flash the code.



## ERROR CODES

Count the number of flashes on front bezel of Bill Acceptor and follow chart for repair.

FLASHING CODE	DESCRIPTION	CORRECTIVE ACTION
LEDs off	Power off	Turn on power
LEDs on	Acceptor is OK	
1 flash	Bill path blockage	Un-jam bill path
2 flashes	Stacker jam	Un-jam stacker
3 flashes	Cassette is full of bills	Empty the cassette
4 flashes	Cassette is removed	Replace the cassette
5 flashes	Acceptor is defective	Replace the acceptor
6 flashes	Acceptor not enabled	See service manual
10 flashes	Configuration Mode	Power down to exit
Rapid flashing during operation	Stringing attempt detected; or sensors dirty	Clean the sensors



# POWER SUPPLY DIAGNOSTICS

- 1.) Verify AC power to front of game. Check power strip in bottom front. Check for illuminated power switch.
- 2.) Verify AC power at power strip in top of game behind monitor. Check for illuminated power switch.

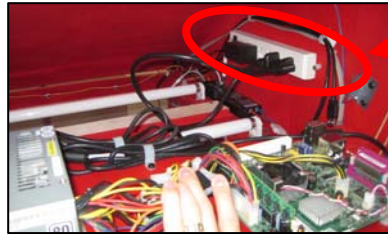
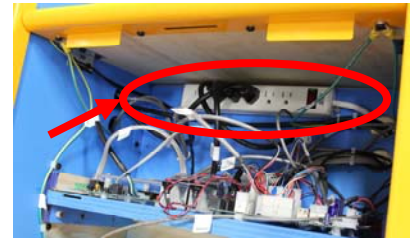

- 3.) Check AC power connection to power supply.
- 4.) Ensure Power Supply switch is set to 115V (or 230V) (Some model power supplies may not have this)
- 5.) Ensure Power switch is on.

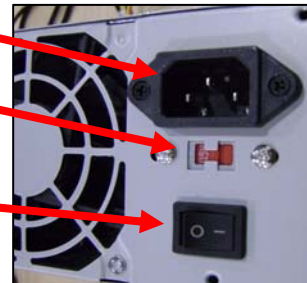

- 6.) Examine top left corner of motherboard. There is green LED ON. **If LED is not ON, replace power supply. (AAPS4600)**

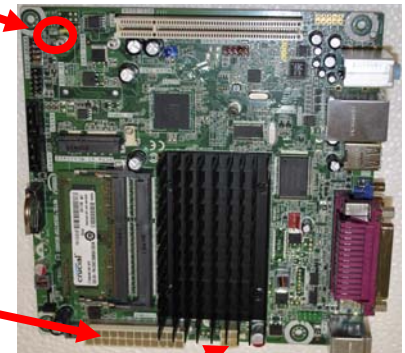

- 7.) Check connections from power supply. Make sure these 2 connections are secure.

- 8.) **“Jump Start” Motherboard:** If green LED is ON, but monitor is not ON, you may start motherboard by quickly touching these 2 red pins at the same time.

Large power supply connection

2 Black and 2 yellow wires (12 Volts DC)

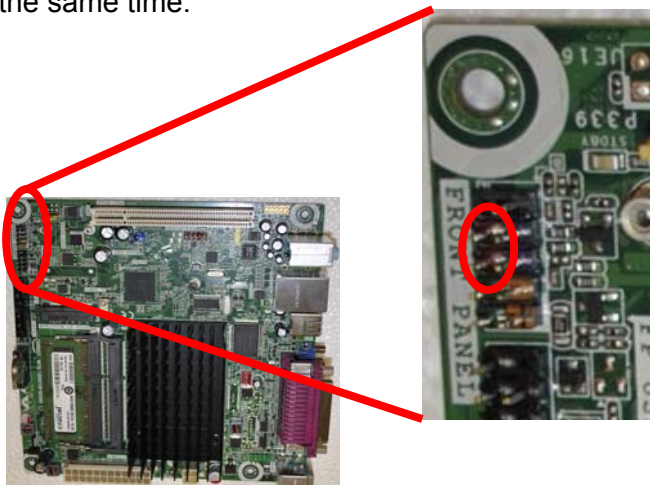

# UPDATING SOFTWARE

## Needed for Software Update:

- #2 Square bit screwdriver
- One USB motherboard software
- One USB stick for MiniGen board

## Installation Instructions:

**Overview** – This software upgrade consists of 2 steps:  
MiniGen software loading.  
Motherboard software installation.

## **MiniGen Software loading - NOTE:** Game power must remain ON for this procedure.

1) Locate the USB stick with the MG designator for MiniGen Board.

2) Access the Minigen main board on bottom front of game. Behind looked door where speaker is located.



3) Insert the USB stick into the main board controller as shown here:



4) To trigger your file to load, press the small pushbutton next to the dipswitches.

**NOTE:** The file will load quickly; you will notice that the USB stick will flash, audio will reset after about 1 second, and the game will return to normal operating condition.

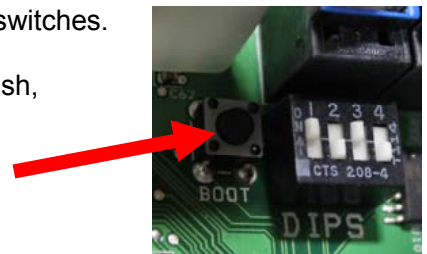

## **Motherboard Software Installation**

- 1) Power down your game and disconnect the main power plug.
- 2) Locate USB software stick with the PC designator for Motherboard.
- 3) Remove existing USB stick and install the new USB stick with PC program.



If you have any questions or need further assistance please contact Bay Tek Games. You may reach our Service Team at 920-822-3951 ext. 1102

# WIRING DIAGRAMS

## MAIN BOARD- AANEWGEN1-PJ

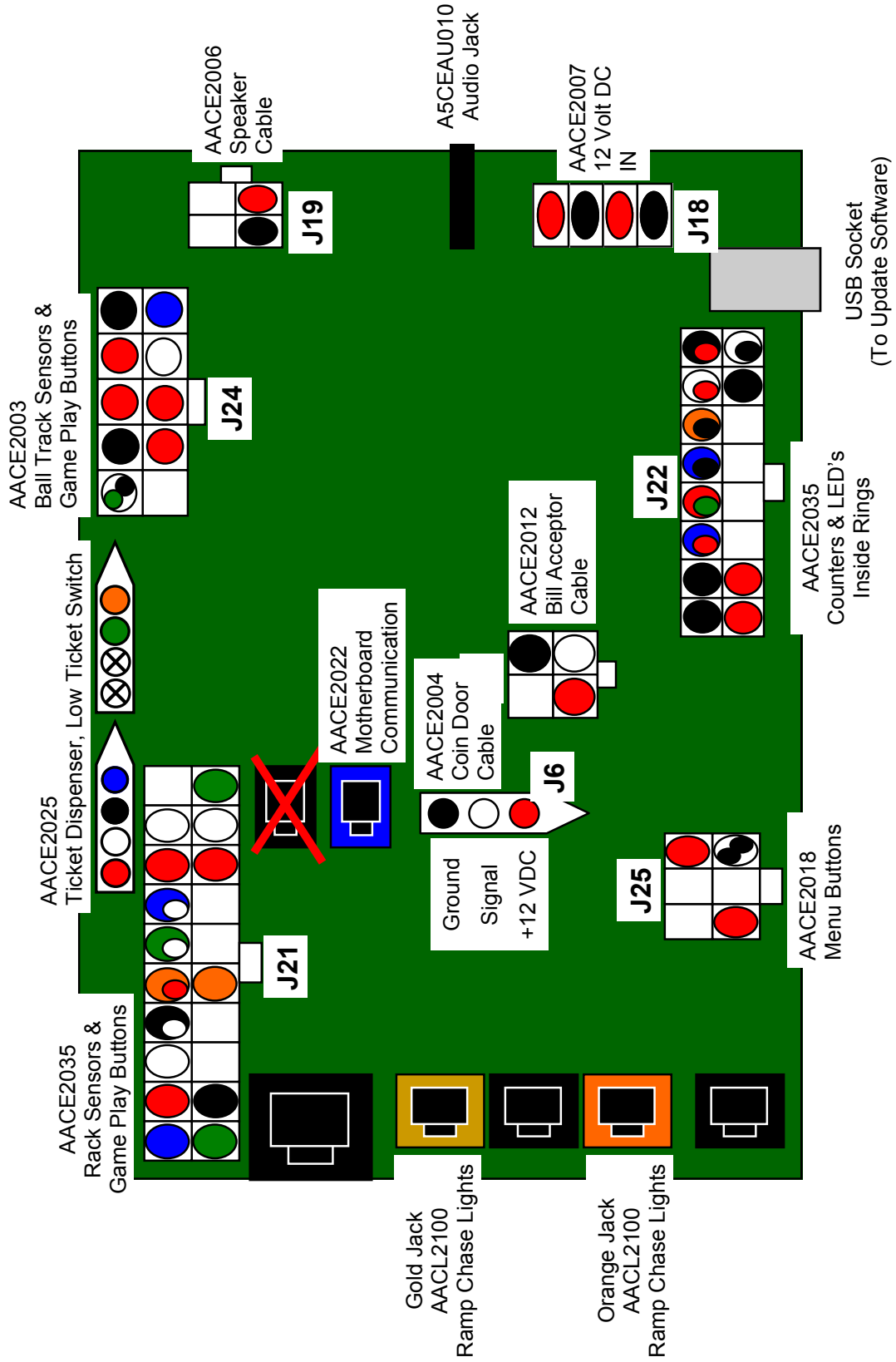

# WIRING DIAGRAMS

## COUNTERS, RACK SENSOR, LEDS

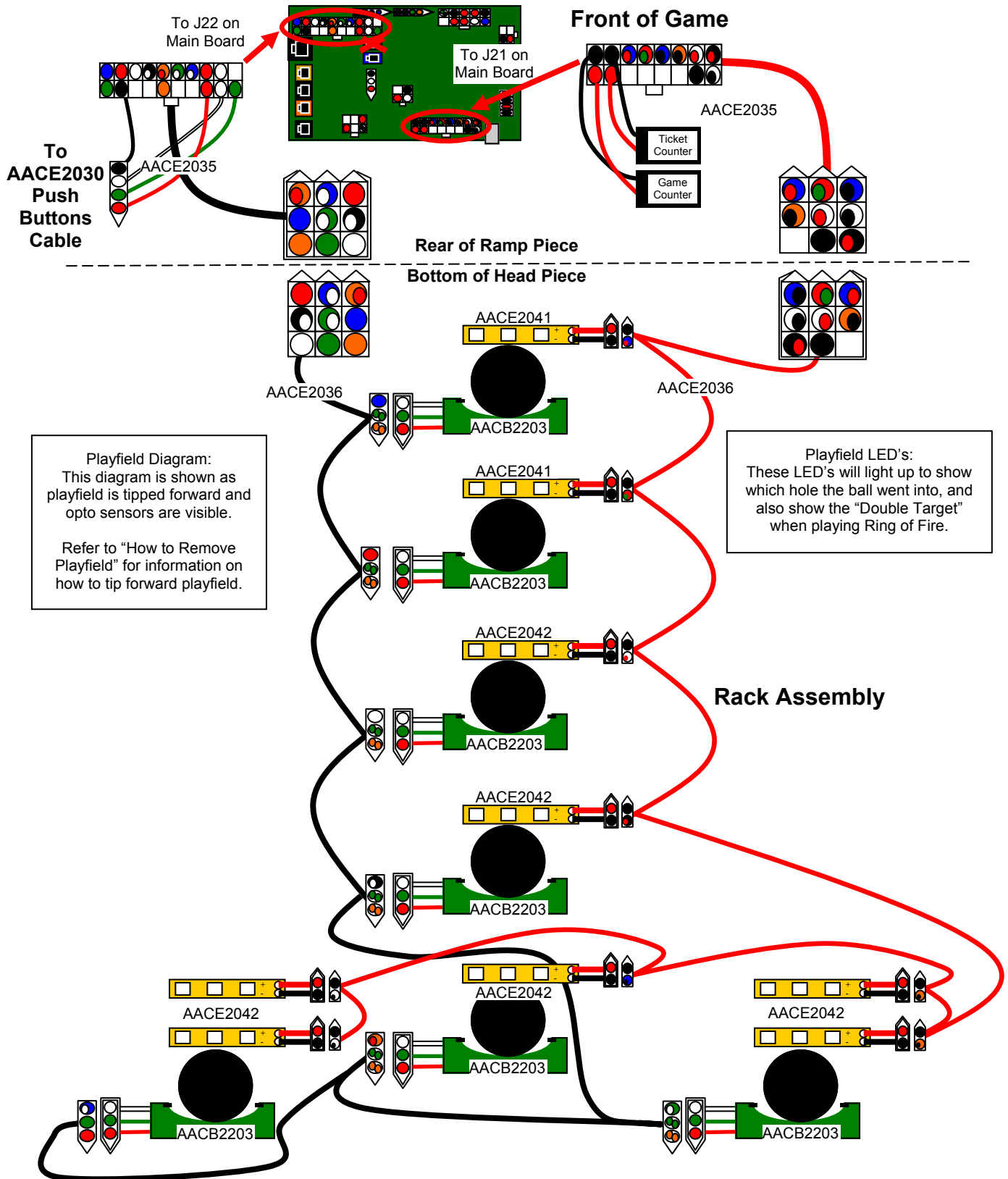

# WIRING DIAGRAMS

## AC & 12 VOLT POWER

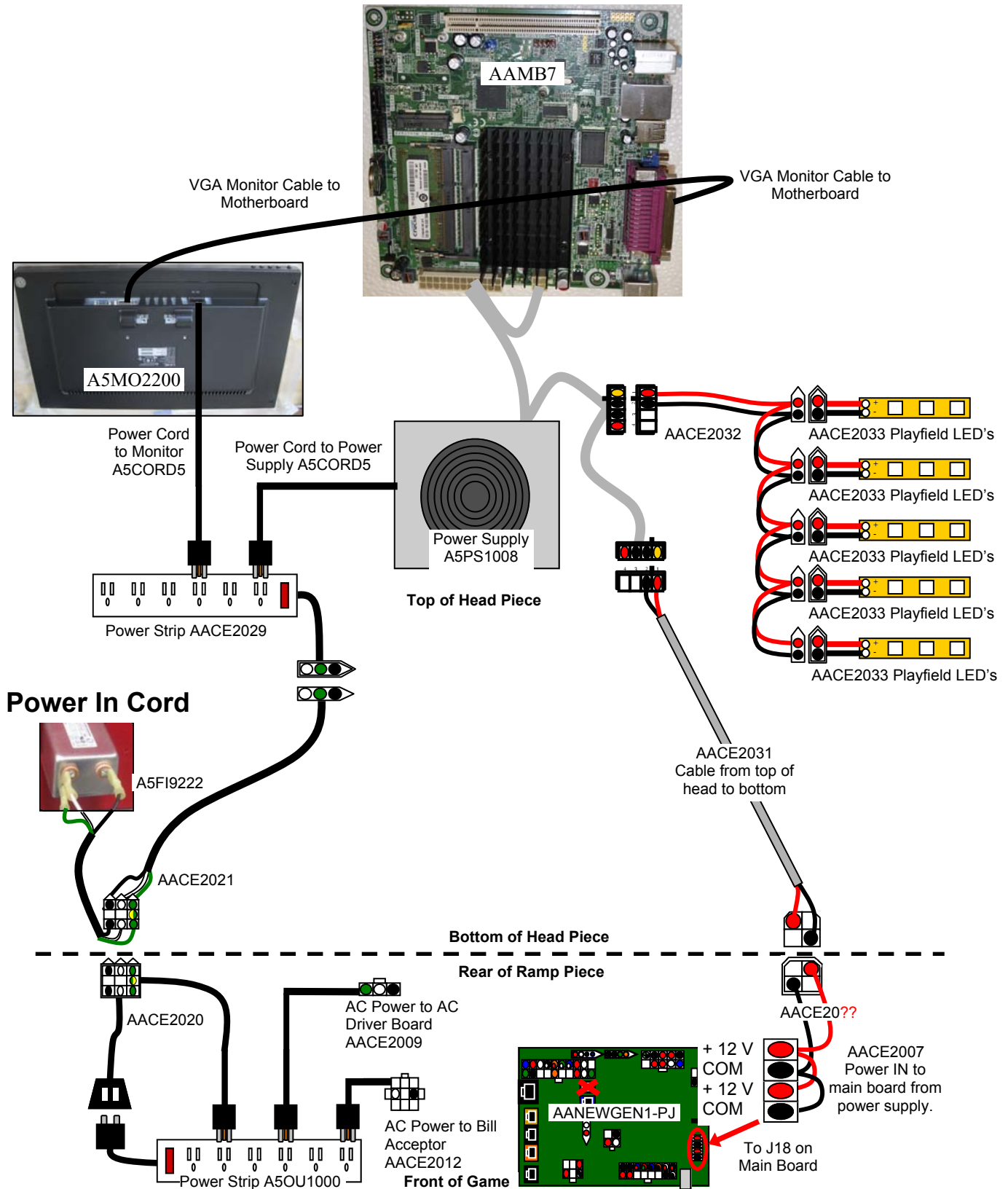

# WIRING DIAGRAMS

## BALL RELEASE & TRACK SENSORS

Ball Release is controlled by signal to AC driver board.

There is a 2 Amp fuse located in black box on board.

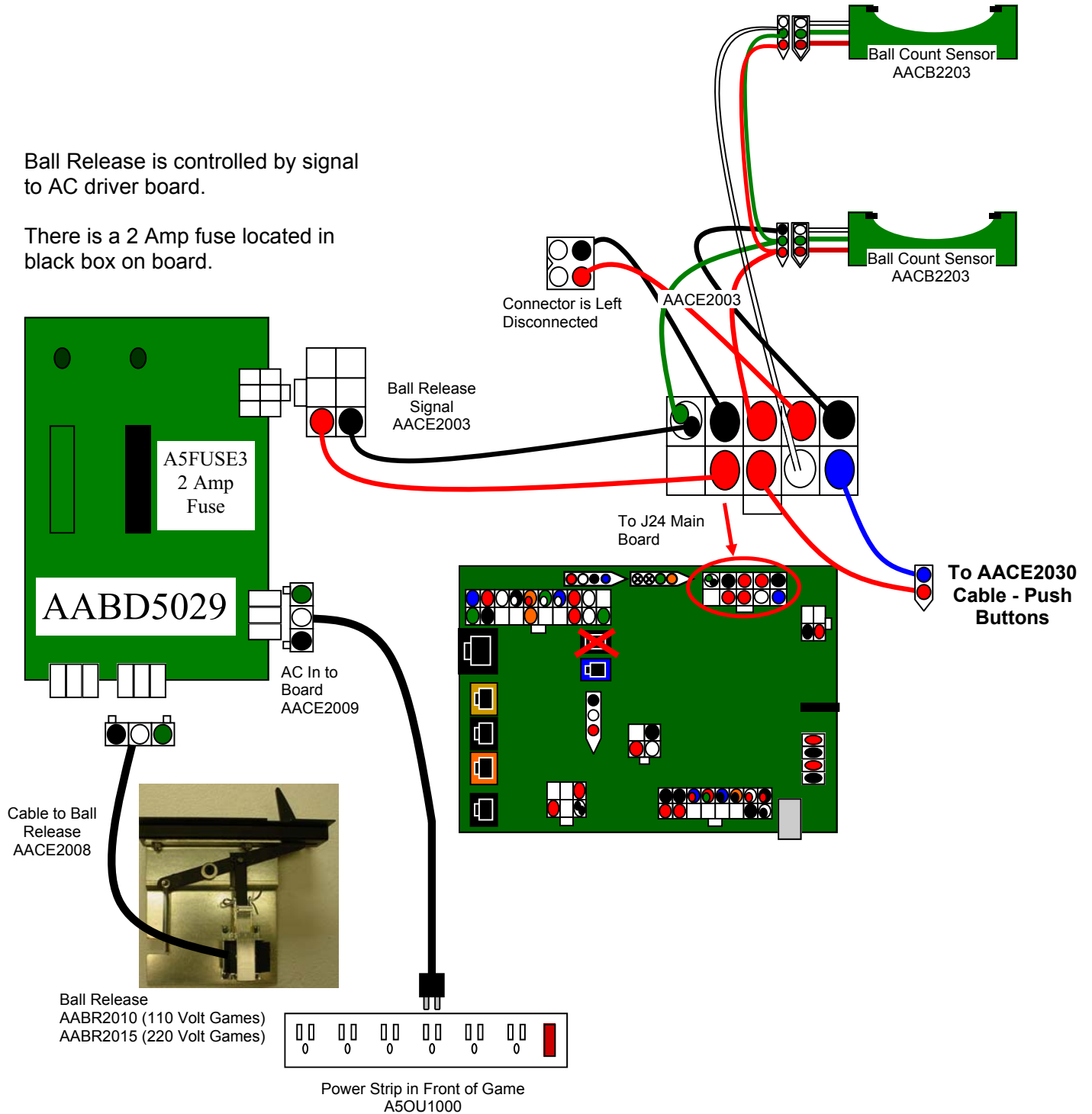

# WIRING DIAGRAMS

## COIN DOOR, TICKET DISPENSER, MENU BUTTONS, SPEAKERS

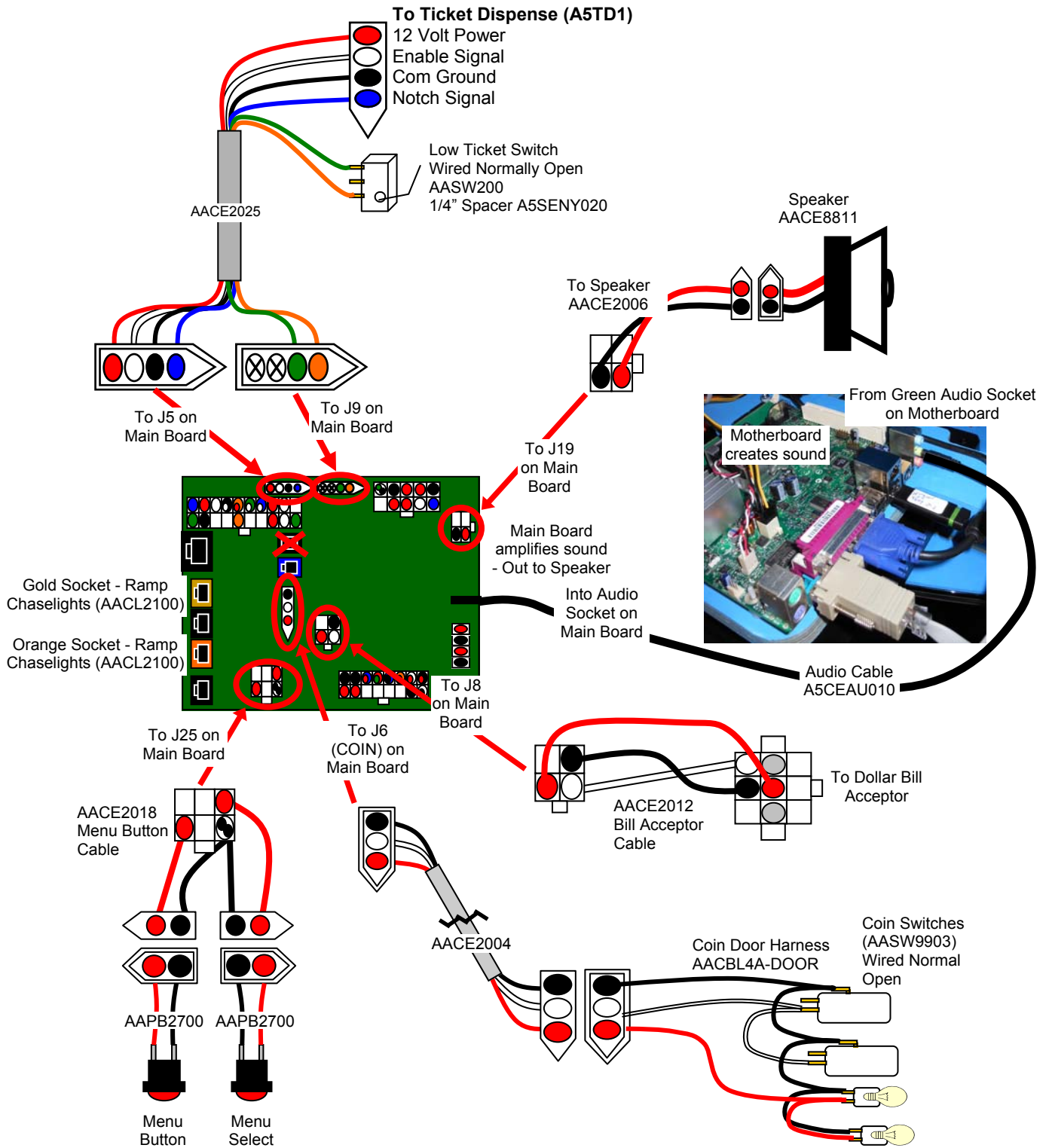

# WIRING DIAGRAMS

## PLAYER GAME SELECT BUTTONS

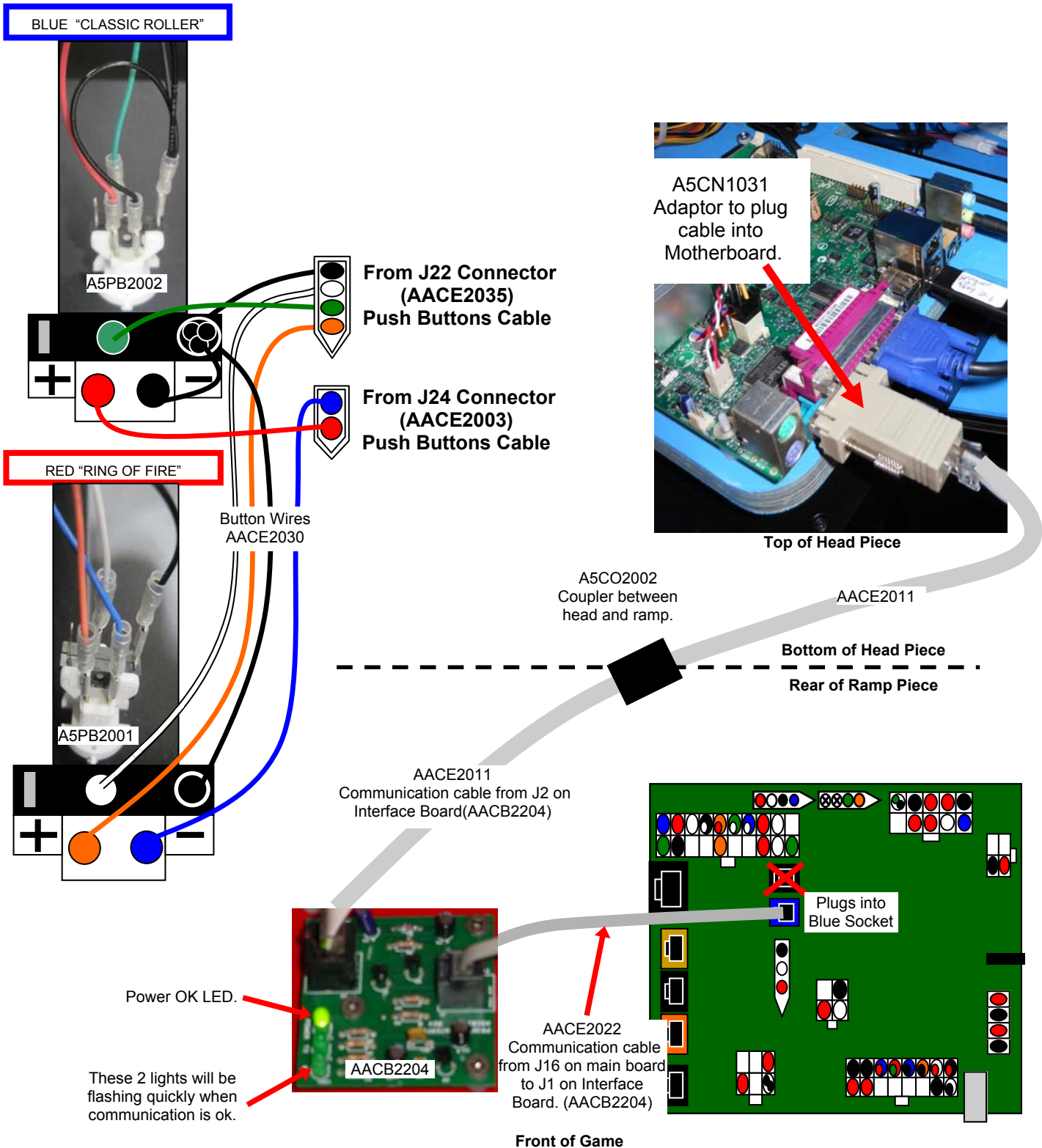

# PARTS LIST

PART NUMBER	DESCRIPTION
A5BA2012	Natural Colored Balls (9 /Game)
A5VF2002	Cash Box
A5CORD5	Computer Cord
A5CO2002	Straight Coupler
A5FI9010	Inline Filter
A5FUSE3	Fuse, 2Amp 250V
A5LK2000	Lock with Key
A5LK5001	Lock with Key
A5MO2200	Monitor, 22 inch
A5OU1000	Outlet Strip
A5PL9097	Blanking Plate
W5TM1117	T-Molding Black W/ Silver .72
AAMA2001	Grey Alley Matting
A5PB2001	Square Push Button (White/Red)
A5PB2002	Square Push Button (Blue)
A5PS1008	Power Supply LS350W
AASW200	Low Ticket Switch
A5TD1	Ticket Dispenser
AACB2203	Scoring Sensor Board (9 Per)
AACB2204	Monitor Interface Board
AACL2100	Ramp Chaselights
AACE8811	Speaker
AAMB7	Computer Motherboard
AANEWGEN1-PJ	Main Board, NewGen, PJ
A5ME2000-FF	Metal Money Door - Left side
A5ME2001-FF	Metal Ball Door
A5ME2002-FF	Electronics Door
A5ME2003-FF	Metal Front Guard
A5ME2004-FF	Metal Lower Coin Door
A5ME2005	Metal Bkt(Under Covers)6 Per
A5ME2006-FF	Metal Coin Door
A5ME2007-FF	Make assembly
A5ME2009-FF	Make assembly
A5ME2010-FF	Metal Lower Electronic Door
A5ME2018	Metal Rails for the Windshield
A5ME2025	Metal Lock Cam
A5ME2026	Metal Lock Bar
A5ME2035	Metal Bracket (Under Return Covers)

PART NUMBER	DESCRIPTION
A5CEAU010	Cable, Audio, Stereo
A5CN1031	Adapter from RJ45 to Motherboard
AACE2003	Ball Switch & Aux Drive Cable
AACE2004	Coin Door Cable
AACE2006	Speaker Cable
AACE2008	AC Solenoid Cable
AACE2009	Aux Drive Power Cable
AACE2011	Back box Display Cable
AACE2012	DBA Power Cord Cable
AACE2018	Push Button Cable
AACE2020	Power Strip to Ramp Cable
AACE2021	Line Filter-Ramp-Light Ballast Cable
AACE2022	Mini Gen-Printer Board, Interface Cable
AACE2025	Ticket Display Cable
AACE2028	Chaselight Cable
AACE2029	Power Strip Cable
AACE2030	Button Cable
AACE2031	Power Supply to Mini Gen1 Cable
AACE2032	LED Jumper Cable
AACE2033	15" Top Light LED Cable
AACE2035	Mini Gen1 to Playfield Ramp Side
AACE2036	Mini Gen1 to Playfield Head Lights Cable
AACE2041	7" LED Playfield Light Cable (2 Per Game)
AACE2042	4" LED Playfield Light Cable (7 Per Game)
AACBL4A-DOOR	Door, Coin Mechanism Cable

# PARTS PICTURES



**A5CORD5**

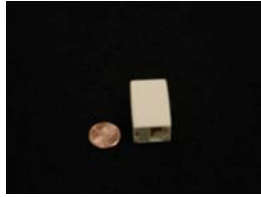

**A5CO2002**



**A5FI9010**



**A5TD1**

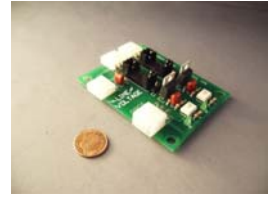

**AABD5029**



**A5LK2000**



**A5LK5001**



**AACE8811**



**A5OU1000**



**A5PL9097**



**A5PB2001**



**A5VF2002**



**A5PS1008**

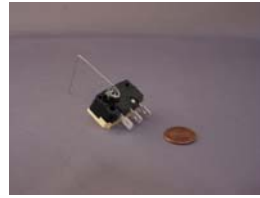

**AASW200**



**A5ME2018**

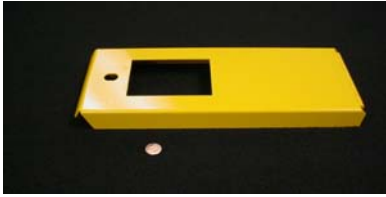

**A5ME2000-FF**

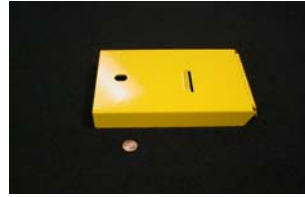

**A5ME2001 -FF**



**A5ME2002-FF**

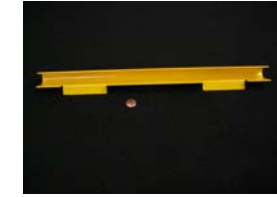

**A5ME2003-FF**

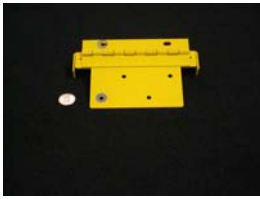

**A5ME2004 -FF**



**A5ME2005**

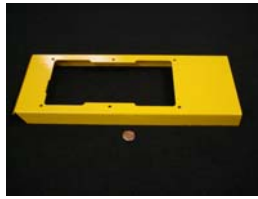

**A5ME2006 -FF**

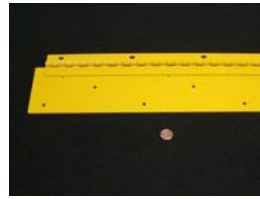

**A5ME2007-FF**



**A5ME2010-FF**



**AACE2003**



**AACE2004**



**AACE2006**



**AACE2020**



**AACE2021**



**AACE2008**



**AACE2009**



**AACE2011**



**AACE2012**



**AACE2018**

# DECAL IDENTIFICATION





# TECHNICAL SUPPORT

Excellent customer service is very important to Bay Tek Games!

We know that keeping your games in great operating condition is important to your business. When you need us, we are here to help. You can call us for free technical assistance, and you can count on us to have parts on-hand to support your game. We offer options that fit your needs.

## Electronics / Circuit Boards - Repair Options

**Repair & Return** – If you have Circuit Board issues with your Bay Tek game, you can send the board to us and we'll repair it right away. Most items sent to us are repaired and returned to you within two days. This option is your best value as we offer this fast turn-around service at the most reasonable price.

**Advance Replacement** – If you have Circuit Board issues with your Bay Tek game, but you don't have time to send in your board in for repair, give us a call and ask for an Advance Replacement. We'll send you a replacement board that same day (pending availability). When you get your new board, just repackage the defective board in the same box and send it back to us. We make it easy by including a UPS Return Shipping label for you to put on the box (not available for international shipments). This is your best option when you need to get your game up and running as quickly as possible!

**Spare Parts** – Take matters into your own hands and purchase new spare Circuit Boards for your Bay Tek games. Many of our games share the same main-board electronics. This means you can buy one set of spare electronics to support many of your Bay Tek games. Spare boards allow you to get your game up and running the quickest and provide you a valuable troubleshooting option. Call our technicians to get recommendations for what you should keep on hand for spare parts!

## Technical Support:

“You” are the best tool for troubleshooting! Your abilities to understand the game and your skills to repair the game are invaluable to us! If you need help, you know you can call us. It's not easy to diagnose a game remotely by phone, but our technicians do a great job. They'll need your help to perform some troubleshooting steps and convey to them exactly what's happening with your game.

## Returns, Credits, & Fees:

**NOTICE!** ALL ITEMS being sent to Bay Tek Games for repair or return, etc. require prior Return Authorization! Bay Tek Games will provide a Product Return Form with an authorizing Ticket Number for each item to be returned. Please be certain to include this document with all shipments!

**Late Fees and Non-Return Fees** - Advance Replacement and Warranty Replacement items require the defective items to be returned by Bay Tek games promptly to avoid Late Fees. We expect items to be returned with 10 working days. Late fees are invoiced monthly. Late fees are non-refundable under any circumstance! Any item not returned within 90 days will be invoiced in full as a replacement part.

**Bench Fees** - Bench fees will apply for each electronic item returned to Bay Tek Games (this includes unused Advance Replacement items). This charge covers our cost to inspect, evaluate and retest each item. Please note that returned items that do not pass our tests will be charged accordingly as replacement items or advance replacements.

**Restocking Fees** - Unused items returned for credit will be credited minus a restocking fee. Items must be returned within 30 days of purchase in order to qualify for any credit amount. No shipping charges will be credited.

# WARRANTY

Bay Tek Games warrants to the original purchaser that all component parts will be free of defects in workmanship and materials for a period of 6 months from the date of purchase. An additional 3 month warranty extension can be obtained by filling out and submitting the Warranty Registration for each machine. Warranty Registration cards may be found as shipped with each machine or online at our website. These must be filled out and submitted to Bay Tek Games within 30 days of purchase to be valid.

For any game/machine we manufacture that is within its warranty period, with notification to our Parts & Service Department, Bay Tek Games will, without charge, repair or replace defective component parts. It is the owner's responsibility to diagnose, remove and replace any faulty component part at their own expense & peril. As needed, at no charge, Bay Tek Games can provide reasonable telephone technical support during our normal business hours.

All claims of defective parts are subject to review upon our inspection of the faulty item. This warranty does not apply in the event of any misuse or abuse to the product, or as a result of any unauthorized repairs or alterations. The warranty does not apply if any serial number decal is altered, replaced or removed from its original position.

To process warranty replacement claims, customers may be charged for the replacement item at the time of shipment and later credited the same amount when the faulty item is returned and has passed our inspection. Bay Tek Games will provide the customer a pre-paid return shipping label which is sent along with the replacement item. The customer is responsible for properly packaging and shipping the faulty item back to Bay Tek Games.

	<b>ATTENTION</b>	
<p>In order to maintain the safety &amp; compliance certifications of this game, <b>ONLY</b> approved parts may be used. For approved replacement parts, refer to the parts list in this manual.</p>		

Should you need your game serviced, determine the serial number from the decal placed on the front of this manual, or locate it on the back of the game. Then contact our Service Department at: 920.822.3951 or e-mail: [service@baytekgames.com](mailto:service@baytekgames.com)

# NON-WARRANTY

Options and estimated charges will be provided to you for your approval.

Please remember that any items being sent to Bay Tek Games must include prior return authorization from our Parts & Service Department.

This approval will include a Product Return Form which is required to be included with any incoming shipments. Repaired parts will be shipped back using the same method in which they were received.

Repairs are warranted for 30 days from the date of return shipment.



