



SKEE-BALL



PLACE SERIAL NUMBER LABEL HERE

FACTORY CONTACT INFORMATION



BAY TEK GAMES INC.
Pulaski Industrial Park
1077 East. Glenbrook Drive
Pulaski, WI 54162 USA

JOIN OUR SERVICE FIRST NETWORK!

This free service is intended to keep you up to date on the latest game information, early notification of parts specials, pertinent technical bulletins, updates on retro fit parts, software upgrades, and much more.

Log on to: www.baytekgames.com/parts
then click on the Parts N' Service tab, or scan the QR code below with your Smartphone to jump straight to this game's parts page!

Scan here!



SALES

P: 920.822.3951

F: 920.822.8936

E: sales@baytekgames.com

PARTS

P: 920.822.3951 X 1101

F: 920.822.1496

E: parts@baytekgames.com

SERVICE

P: 920.822.3951 X 1102

F: 920.822.1496

E: service@baytekgames.com

MON - FRI
8 AM - 5 PM C.S.T.

All games are proudly manufactured at our factory in Pulaski, Wisconsin, USA

TABLE OF CONTENTS

FACTORY CONTACT INFORMATION	2
WELCOME TO: Skee Ball Classic	4
HOW TO PLAY	5
SPECIFICATIONS	6
SAFETY PRECAUTIONS	6
SET UP GUIDE	7-8
DIP SWITCH SETTINGS	9
MAIN MENU FUNCTIONS	10-18
CIRCUIT BOARD PINOUTS	19-21
WIRING DIAGRAMS	22-26
TROUBLESHOOTING GUIDE	27-31
BILL ACCEPTOR DIAGNOSTICS	32
POWER SUPPLY DIAGNOSTICS	33
HOW TO: UPDATE SOFTWARE	34
HOW TO SET UP FREE PLAY	35
PARTS LIST	36
PARTS PICTURES	37-38
DECAL DIAGRAM	39
JACKPOT A5NEWGEN1	40
MARQUEE WIRING DIAGRAMS	41-42
MARQUEE SIGN PARTS	43
MARQUEE SIGN PARTS PICTURES	44
MAINTENANCE LOG	45
TECHNICAL SUPPORT	46
WARRANTY	47

WELCOME TO: Skee Ball Classic

Congratulations on your Skee Ball Classic purchase!

This original alley is a staple for any venue and is a proven revenue producer! The Classic game entices players to play game after game, improving their skill and is packed with action!

Please take a moment to read through this manual and be sure to contact our factory if you have any questions, or would like some more information.

Thank you for your purchase! Your business is important to us and we hope you enjoy this game as much as we do!

Your Friends at Bay Tek Games



GAME INSPECTION

Inspect the game for any damaged, loose, or missing parts.

If damage is found, please contact your freight carrier first.

Then, contact Bay Tek Games' Service Department at 920.822.3951 or e-mail them at service@baytekgames.com for further assistance.

HOW TO PLAY

Roll 9 balls up the ramp and into the playfield.



Win tickets according to your score!



GAME SPECIFICATIONS

WEIGHT	
NET WEIGHT	485 LBS.
SHIP WEIGHT	540 LBS.
DIMENSIONS	
WIDTH	37.25"
DEPTH	38"
HEIGHT	78" (98" with marquee)
OPERATING TEMPERATURE	
FAHRENHEIT	80-100
CELSIUS	26.7-37.8

POWER REQUIREMENTS			
INPUT VOLTAGE RANGE	100 to 120 VAC	/	220 to 240 VAC
INPUT FREQUENCY RANGE	50 HZ	/	60 HZ

MAX OPERATING CURRENT	
1.4 AMPS @ 115 VAC	
.8 AMPS @ 230 VAC	

SAFETY PRECAUTIONS

NOTICE	
Modifications to the mechanical, electrical and structural components of this game may void its compliance certifications.	
This appliance is suitable for INDOOR, DRY locations only.	
DANGER	
DO NOT perform repairs or maintenance on this game with the power ON. Unplug the unit from the wall outlet or shut off the power strip located inside the cabinet.	
WARNING	
Use of flammable substances can cause sever burns or serious injury. Always use NON-FLAMMABLE solvents for cleaning. DO NOT use gasoline kerosene or thinners.	
CAUTION	
Lifting heavy objects can cause back, neck or other injuries. Be sure adequate lifting and moving devices are available when unloading, unpacking and moving this game.	
ATTENTION	
Be sure the electrical power matches the game requirements. See the serial number located on the back of the game cabinet. Always plug into a grounded circuit. If the supply cord is damaged, it must be replaced by an approved cord or assembly provided by the manufacturer. A shielded power cable must be used for the game to retain EU/EMC compliance.	
IN CASE OF EMERGENCY	
UNPLUG THE POWER CORD. The power cord must be accessible at all times in case of an emergency.	

SET UP GUIDE

Use the key to unlock the left side ramp cover.
Remove the cover to locate the 9 brown balls.

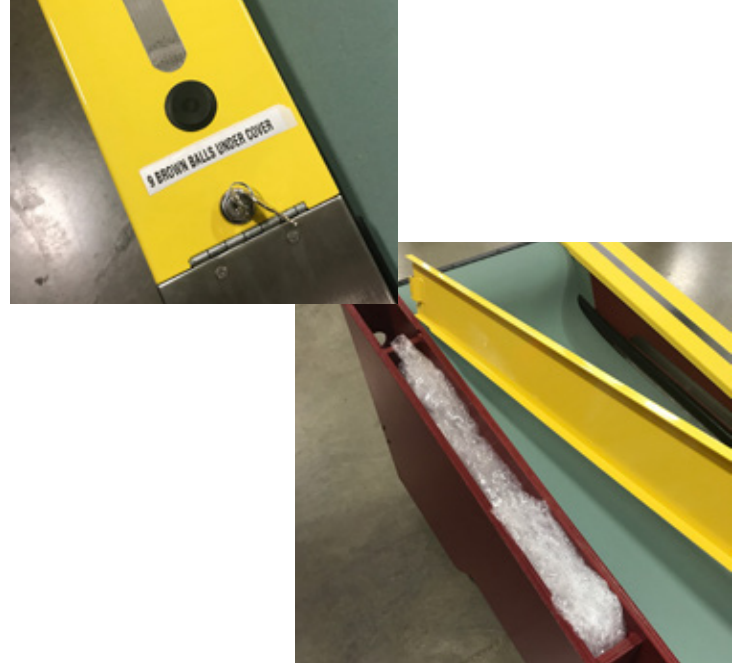

Remove the packing to expose the brown balls.
Remove the balls and set aside.

Replace the ramp cover.



Place the target cabinet near its desired location.
Push the alley ramp near the target cabinet.



SET UP GUIDE CONT.

Plug in the four cables between the target cabinet and the ramp, then push them together.

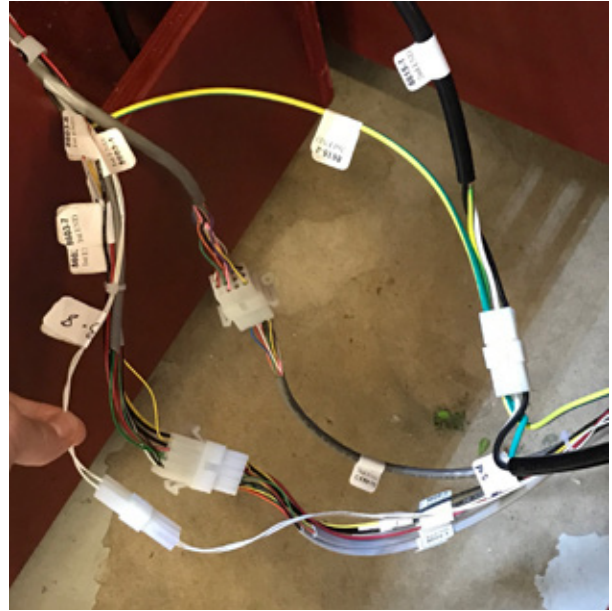

Using the 5/16" allen wrench in the box of balls, turn the latches on either side of the ramp into the hasps on the target cabinet to secure them together.



Plug the cabinet into a standard electrical outlet and turn the power strip to ON.

Place the 9 brown balls into the playfield.
You're ready to roll!

DIP SWITCH SETTINGS

The dip switch bank is located on the mainboard,
inside the front door of the game.

*factory default settings are highlighted below

SWITCH	DESCRIPTION	ON	OFF
1			X
2	New Jersey Programming		X
3	Home Mode		X
4	Amusement Only Mode		X

SWITCH 3 - HOME MODE: Menu mode controls game volume only
No tickets dispensed or displayed
Single push button starts game or stores game credits

SWITCH 4 - AMUSEMENT ONLY: Single game credit only (credits cleared at game over)

MAIN MENU FUNCTIONS

Press and hold the MENU button to enter the game menu.

Scroll through each sub-menu with the MENU SELECT button.

Press MENU to move to the next sub-menu.

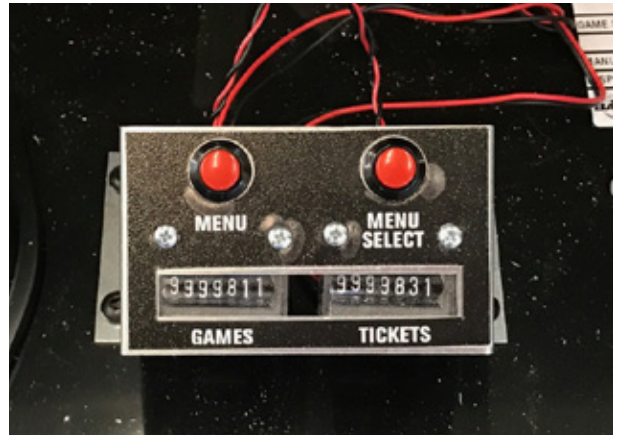

MENU	DESCRIPTION	MENU	DESCRIPTION
1	CREDITS PER PLAY	13	CREDIT TYPE
2	GAME VOLUME	14	CREDIT PER DISCOUNT
3	ATTRACT VOLUME	15	GAMES PER DISCOUNT
4	ATTRACT TIMER	16	HIGH SCORE BASE
5	INITIAL TICKET SCORE	17	HIGH SCORE TYPE
6	TICKET SPAN	18	BALL TIMEOUT
7	TICKET SPAN AMOUNT	19	LAST SCORE
8	MERCY TICKETS	20	JACKPOT PAYMENT TYPE
9	DIVIDE BY TWO	21	MIDWAY LAST GAME HIGH
10	FIXED TICKET PAYOUT	22	MIDWAY LAST GAME HIGH TIMER
11	STORE CREDITS	23	GAME MODE
12	BALLS PER GAME	24	RESET FACTORY DEFAULTS

MENU 1- CREDITS PER PLAY

Scroll through menu 1 with the “MENU” button.
Make your selection with the “SELECT” button.
The factory settings are highlighted below.

1	2	3	4	5	6	7	8
---	---	---	---	---	---	---	---

MENU 2- GAME VOLUME

Scroll through menu 2 with the “MENU” button.
Make your selection with the “SELECT” button.
The factory settings are highlighted below.

0	1	2	3	4	5	6	7
---	---	---	---	---	---	---	---

MENU 3- ATTRACT VOLUME

Scroll through menu 3 with the “MENU” button.
Make your selection with the “SELECT” button.
The factory settings are highlighted below.

0	1	2	3	4	5	6	7
---	---	---	---	---	---	---	---

MENU 4- ATTRACT TIMER

Scroll through menu 4 with the “MENU” button.
Make your selection with the “SELECT” button.
The factory settings are highlighted below.

0	30 SECONDS	1 MINUTE	5 MINUTES	10 MINUTES	15 MINUTES
---	---------------	-------------	--------------	---------------	---------------

MENU 5- INITIAL TICKET SCORE

Scroll through menu 5 with the “MENU” button.
Make your selection with the “SELECT” button.
The factory settings are highlighted below.

This option determines how many points must be scored before the first ticket is dispensed.

ADJUSTABLE IN INCREMENTS OF 10			
0	TO	950	150 DEFAULT

MENU 6- TICKET SPAN

Scroll through menu 6 with the “MENU” button.
Make your selection with the “SELECT” button.
The factory settings are highlighted below.

This option determines the intervals that tickets will be issued.

Example: if the INITIAL TICKET SCORE is set to 150 and the TICKET SPAN is set to 30, the first ticket is issued at 150 and the next one would be at 180, then 210, and every 30 points thereafter.

ADJUSTABLE IN INCREMENTS OF 10			
0	TO	300	10 DEFAULT

MENU 7- TICKET SPAN AMOUNT

Scroll through menu 7 with the “MENU” button.
Make your selection with the “SELECT” button.
The factory settings are highlighted below.

This option is used to determine the amount of tickets paid for the INITIAL TICKET SCORE and TICKET SPAN settings.

ADJUSTABLE IN INCREMENTS OF 1			
1	TO	100	1 DEFAULT

MENU 8- MERCY TICKETS

Scroll through menu 8 with the “MENU” button.
Make your selection with the “SELECT” button.
The factory settings are highlighted below.

0	1	2	3	4	5
----------	----------	----------	----------	----------	----------

MENU 9- DIVIDE BY TWO

Scroll through menu 9 with the “MENU” button.
Make your selection with the “SELECT” button.
The factory settings are highlighted below.

0 (OFF)	1 (ON)
-------------------	------------------

MENU 10- FIXED TICKET PAYOUT

Scroll through menu 10 with the “MENU” button.
Make your selection with the “SELECT” button.
The factory settings are highlighted below.

Fixed ticket payout sets all targets to the designated ticket value.

ADJUSTABLE IN INCREMENTS OF 1			
0	TO	15	0 DEFAULT

MENU 11- STORE CREDIT

Scroll through menu 11 with the “MENU” button.
Make your selection with the “SELECT” button.
The factory settings are highlighted below.

Enabling stored credits will save credits owed in case of a power outage.

NO	YES
-----------	------------

MENU 12- BALLS PER GAME

Scroll through menu 12 with the “MENU” button.
Make your selection with the “SELECT” button.
The factory settings are highlighted below.

3	4	5	6	7	8	9
---	---	---	---	---	---	---

MENU 13- CREDIT TYPE

Scroll through menu 13 with the “MENU” button.
Make your selection with the “SELECT” button.
The factory settings are highlighted below.

SWIPE	COINS	TOKENS	BILLS
-------	-------	--------	-------

MENU 14- CREDIT PER DISCOUNT

Scroll through menu 14 with the “MENU” button.
Make your selection with the “SELECT” button.
The factory settings are highlighted below.

This option is used to give the player free game(s) for every XX credits they buy at once. EX: if the option is set to ‘2’, then for every 2 credits bought (at the same time), XX game(s) are given for free. If the game is set to ‘4’, then for every 4 credits bought (at the same time), XX game(s) are given for free.

ADJUSTABLE IN INCREMENTS OF 1			
0	TO	99	0 DEFAULT

MENU 15- GAMES PER DISCOUNT

Scroll through menu 15 with the “MENU” button.
Make your selection with the “SELECT” button.
The factory settings are highlighted below.

This option is used to determine the number of free games given when a player utilizes the ‘CREDIT PER DISCOUNT’ option. EX: if the ‘CREDIT PER DISCOUNT’ option is set to ‘2’, then for every 2 credits bought (at the same time), the player will receive the number of free games that this option is set to.

ADJUSTABLE IN INCREMENTS OF 1			
1	TO	3	1 DEFAULT

MENU 16- HIGH SCORE BASE

Scroll through menu 16 with the “MENU” button.
Make your selection with the “SELECT” button.
The factory settings are highlighted below.

Displays the last games score, in the attract mode.

ADJUSTABLE IN INCREMENTS OF 1			
200	TO	500	360 DEFAULT

MENU 17- HIGH SCORE TYPE

Scroll through menu 17 with the “MENU” button.
Make your selection with the “SELECT” button.
The factory settings are highlighted below.

This option can be set one of three ways:

RESET EVERY 99 GAMES - this mode will reset the high score value every 99 games, regardless of whether or not the game has been shut off.

DOES NOT RESET - in this mode, the high score will never reset.

RESET EVERY POWER UP - this mode will allow the game to reset the high score value every time the game is shut down and powered back on.

OFF - this mode will not display any high score during attract mode.

99	NEVER	POWER	OFF
----	-------	-------	-----

MENU 18- BALL TIMEOUT

Scroll through menu 18 with the “MENU” button.
Make your selection with the “SELECT” button.
The factory settings are highlighted below.

This option is used in case a ball is lost or not thrown soon enough. If a ball is not played within the allotted time, the ball counter will advance.

0	30 SECONDS	1 MINUTE	2 MINUTES	3 MINUTES	5 MINUTES
---	---------------	-------------	--------------	--------------	--------------

MENU 19- LAST SCORE

Scroll through menu 19 with the “MENU” button.
Make your selection with the “SELECT” button.
The factory settings are highlighted below.

Displays the last games score, in the attract mode.

NO	YES
-----------	------------

MENU 20- JACKPOT PAYMENT TYPE

Scroll through menu 20 with the “MENU” button.
Make your selection with the “SELECT” button.
The factory settings are highlighted below.

This setting selects how the jackpot tickets will pay out in conjunction with continued attract or game play

DISPENSE: Next game play or attract mode will continue while jackpot tickets are being dispensed

ATTENDANT: Plays the jackpot sound continually until an attendant presses the “SELECT” button

WAIT: Next game play and/or attract mode will not begin until all jackpot tickets have been dispensed

DISPENSE	ATTENDANT	WAIT
-----------------	------------------	-------------

MENU 21- MIDWAY LAST GAME HIGH

Scroll through menu 21 with the “MENU” button.
Make your selection with the “SELECT” button.
The factory settings are highlighted below.

ADJUSTABLE IN INCREMENTS OF 10'S			
0	TO	900	0 DEFAULT

MENU 22- MIDWAY LAST GAME HIGH TIMER

Scroll through menu 22 with the “MENU” button.
Make your selection with the “SELECT” button.
The factory settings are highlighted below.

This option sets the number of seconds the ‘midway win lights’ will remain on, after the “midway last game high score” is achieved.

0	30	60	90
----------	-----------	-----------	-----------

MENU 23- GAME MODE

Scroll through menu 23 with the “MENU” button.
Make your selection with the “SELECT” button.
The factory settings are highlighted below.

This setting selects which game mode the game will be set to

NORMAL: All current menu settings used

SHOW: Single credit (or push of start button connected to credit input) starts game
Single game credit only (credits cleared at game over)
No tickets dispensed

AMUSEMENT ONLY: Game starts when the number of credits per play is met
Multiple game credits allowed (unless DIP4 is set)
No tickets dispensed or displayed

NORMAL/TICKETS	SHOW	AMUSEMENT ONLY/ POINTS
-----------------------	-------------	-----------------------------------

MENU 24- RESET FACTORY DEFAULTS

Press the SELECT button to reset the game to factory settings.
Display will read “SUCCESS!” when done.

MAINBOARD PINOUT GUIDE

Pin Type	Purpose	Ref	Pin #
LOWSIDE #1, w diode	Mechanical Count #1 Game	J22	1
LOWSIDE #2, w diode	Mechanical Count #2 Ticket	J22	2
LOWSIDE #3		J22	3
LOWSIDE #4		J22	4
LOWSIDE #5		J22	5
LOWSIDE #6		J22	6
LOWSIDE #7		J22	7
LOWSIDE #8	Head White Light 1	J22	8
LOWSIDE #9	Head White Light 2	J22	9
+12 Volts		J22	11
+12 Volts		J22	12
+12 Volts		J22	13
+12 Volts		J22	14
+12 Volts		J22	15
+12 Volts		J22	16

HIGHSIDE #13		J25	1
HIGHSIDE #14		J25	2
PX10	Service Button #1	J25	3
PX11	Service Button #2	J25	4
Ground	Ground for Service Buttons	J25	5
Ground		J25	6

PX37	Ticket Notch #1	J5	1
Ground	Ground for Ticket Dispenser	J5	2
PB18	Ticket Motor #1	J5	3
+12 Volts	Power for Ticket Dispenser	J5	4

+12 Volts	Coin Door Power	J6	1
PA05	Coin Input	J6	2
Ground	Coin Ground	J6	3

PB16	Low Ticket Switch	J9	1
Ground	Ground for Low Ticket Switch	J9	2
PB17	Unused	J9	3
+12 Volts		J9	4

PA06	DBA Input	J8	1
+12 Volts		J8	2
Ground		J8	3
Ground		J8	4

=Low Side Driver
=High Side Driver
= TTL Input/Output
= LED Constant Current Drive
= 12 Volts
= Ground

Pin Type	Purpose	Ref	Pin #
Ground		J24	1
Ground		J24	2
+12 Volts		J24	3
+12 Volts		J24	4
PB7	Ball Release Sensor	J24	5
LOWSIDE #12	Win Beacon	J24	6
PX29	Ball Trough Sensor	J24	7
HIGHSIDE #1		J24	8
HIGHSIDE #2	Ball Release Solenoid	J24	9
3.3V		J24	10

PB19	10 Point Sensor	J21	1
PX39	20 Point Sensor	J21	2
PX00	30 Point Sensor	J21	3
PX01	40 Point Sensor	J21	4
PB20	50 Point Sensor	J21	5
PX02	100 Point Sensor Left	J21	6
PB21	100 Point Sensor Right	J21	7
PB22		J21	8
PB23		J21	9
PB24	Jersey Coin Lockout	J21	10
Ground		J21	11
Ground		J21	12
Ground		J21	13
Ground		J21	14
+12 Volts		J21	15
+12 Volts		J21	16
+12 Volts		J21	17
+12 Volts		J21	18
PB25		J21	19
PB26		J21	20

A5NEWGEN 1 PINOUT

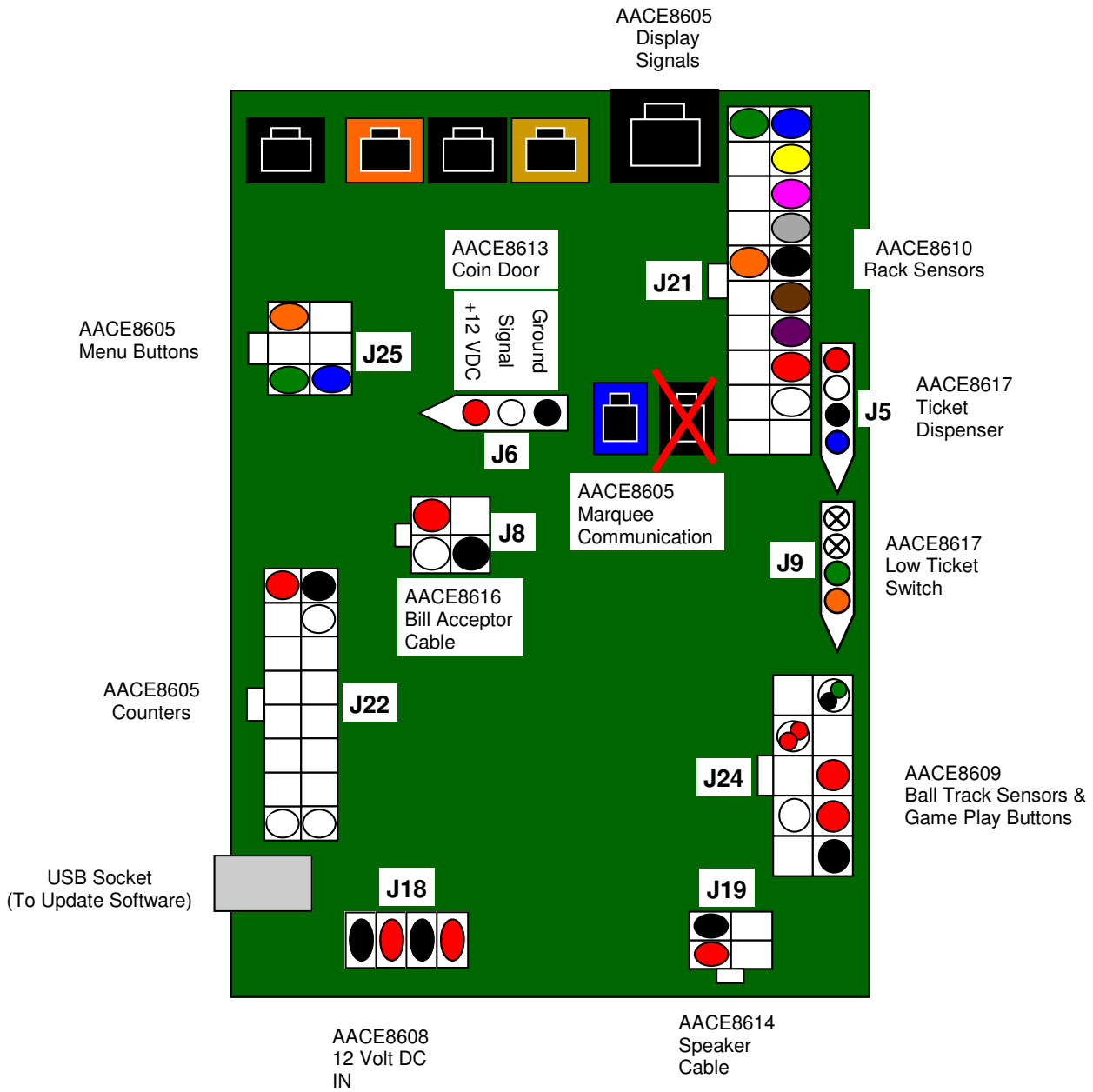

WIRING DIAGRAM

POWER & 12V

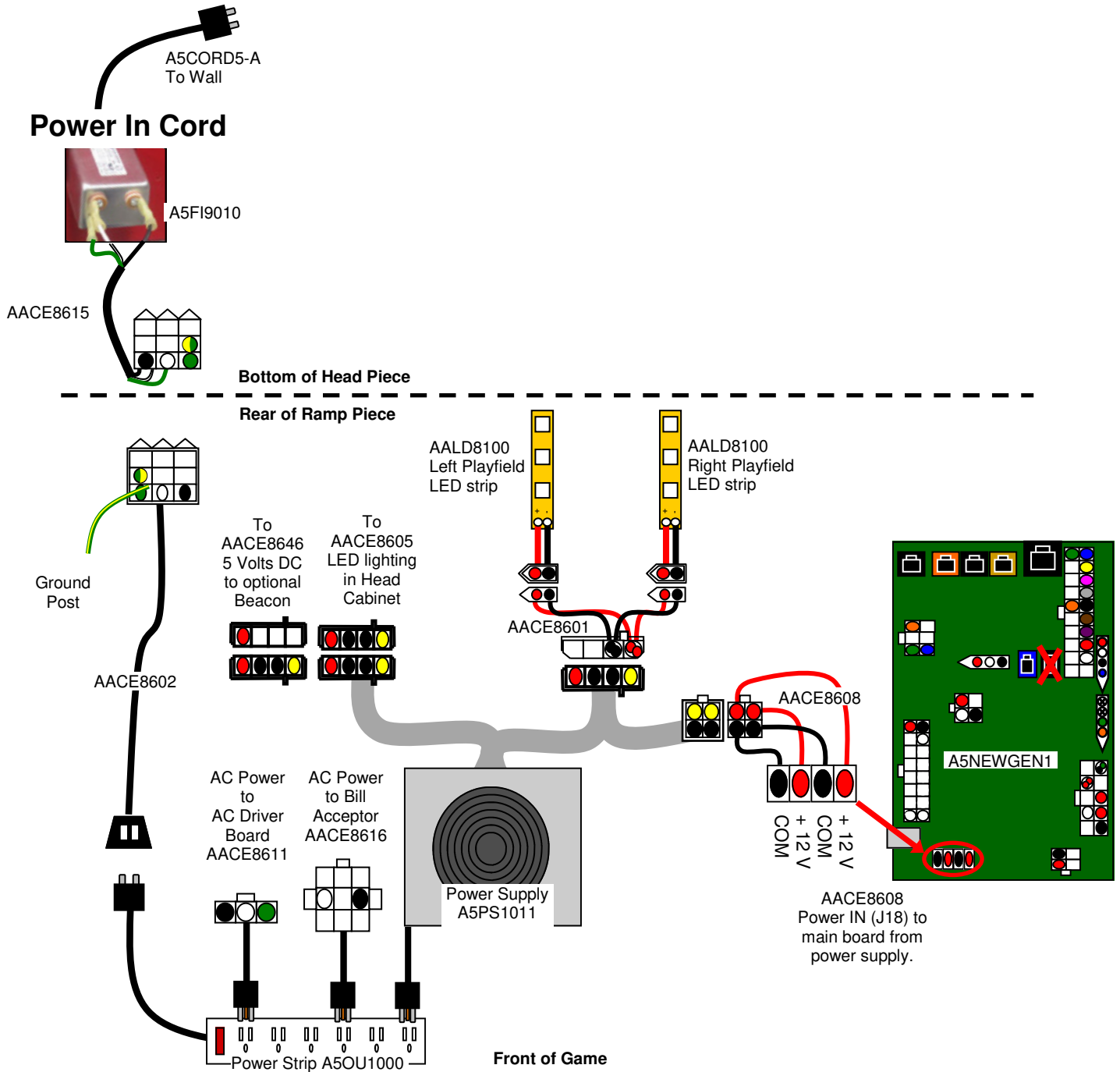

WIRING DIAGRAM

SCORE SENSORS

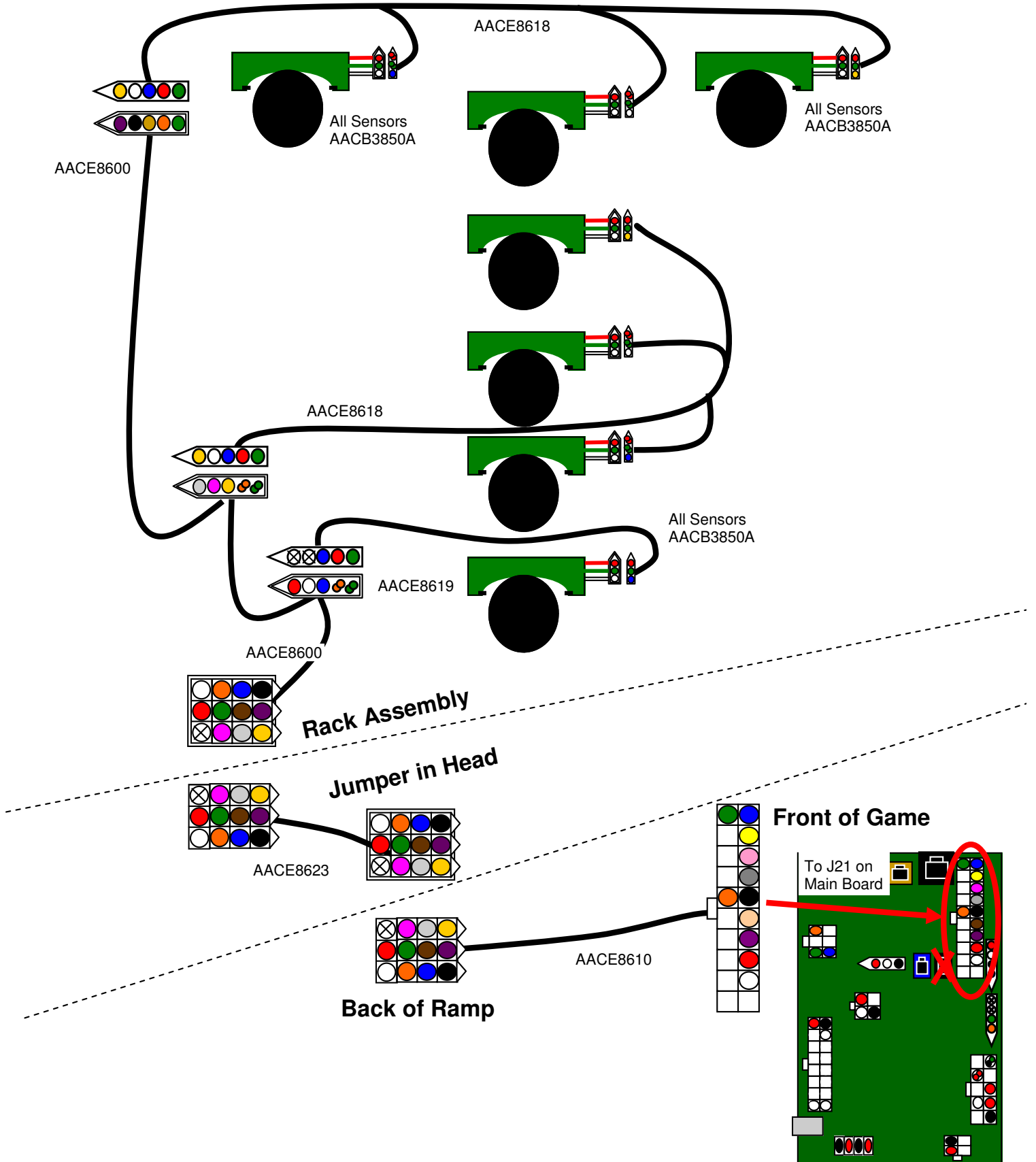

WIRING DIAGRAM

BALL RELEASE & BALL TRACK SENSORS

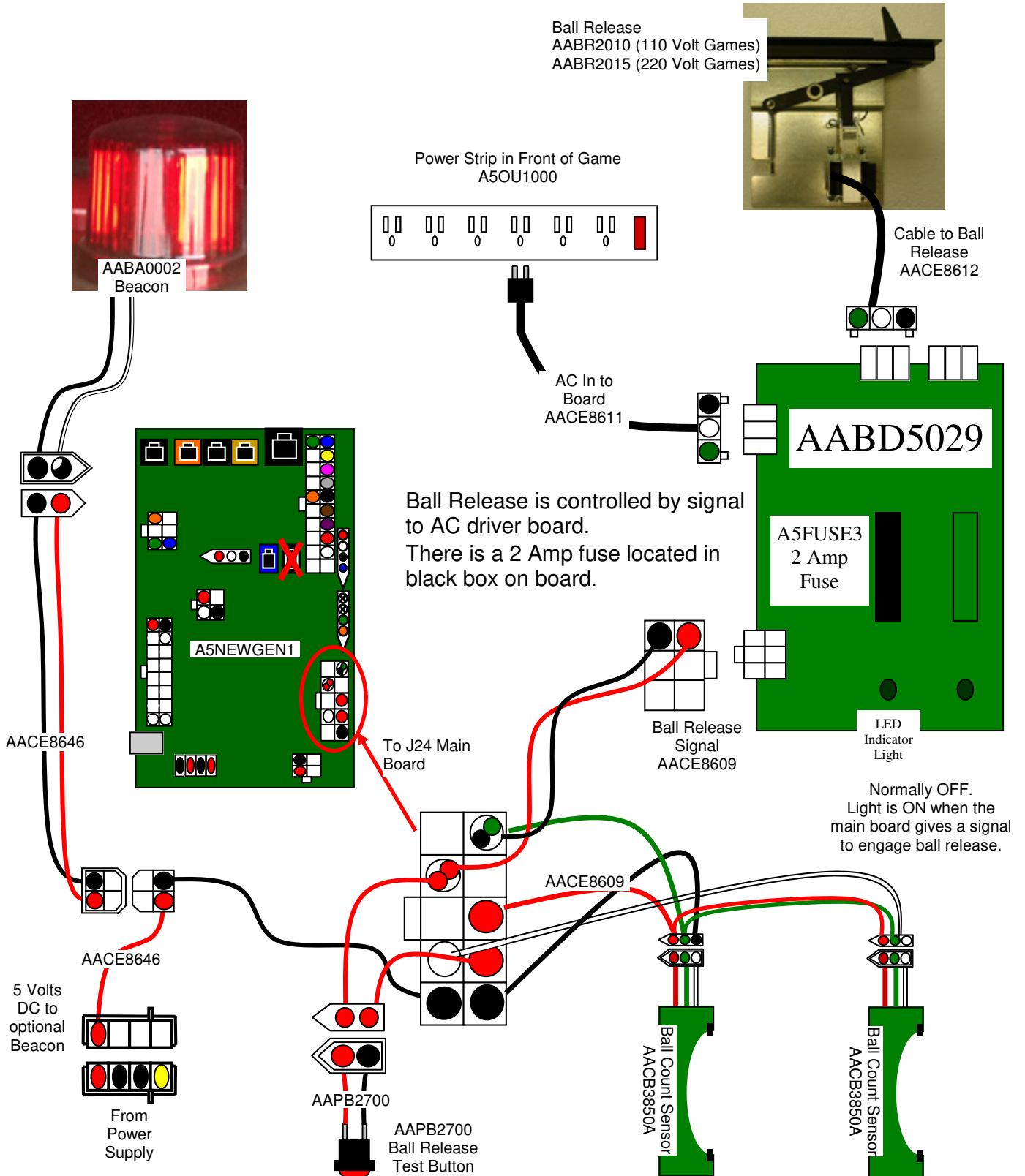

WIRING DIAGRAM

COIN, TICKET, DBA & SPEAKER

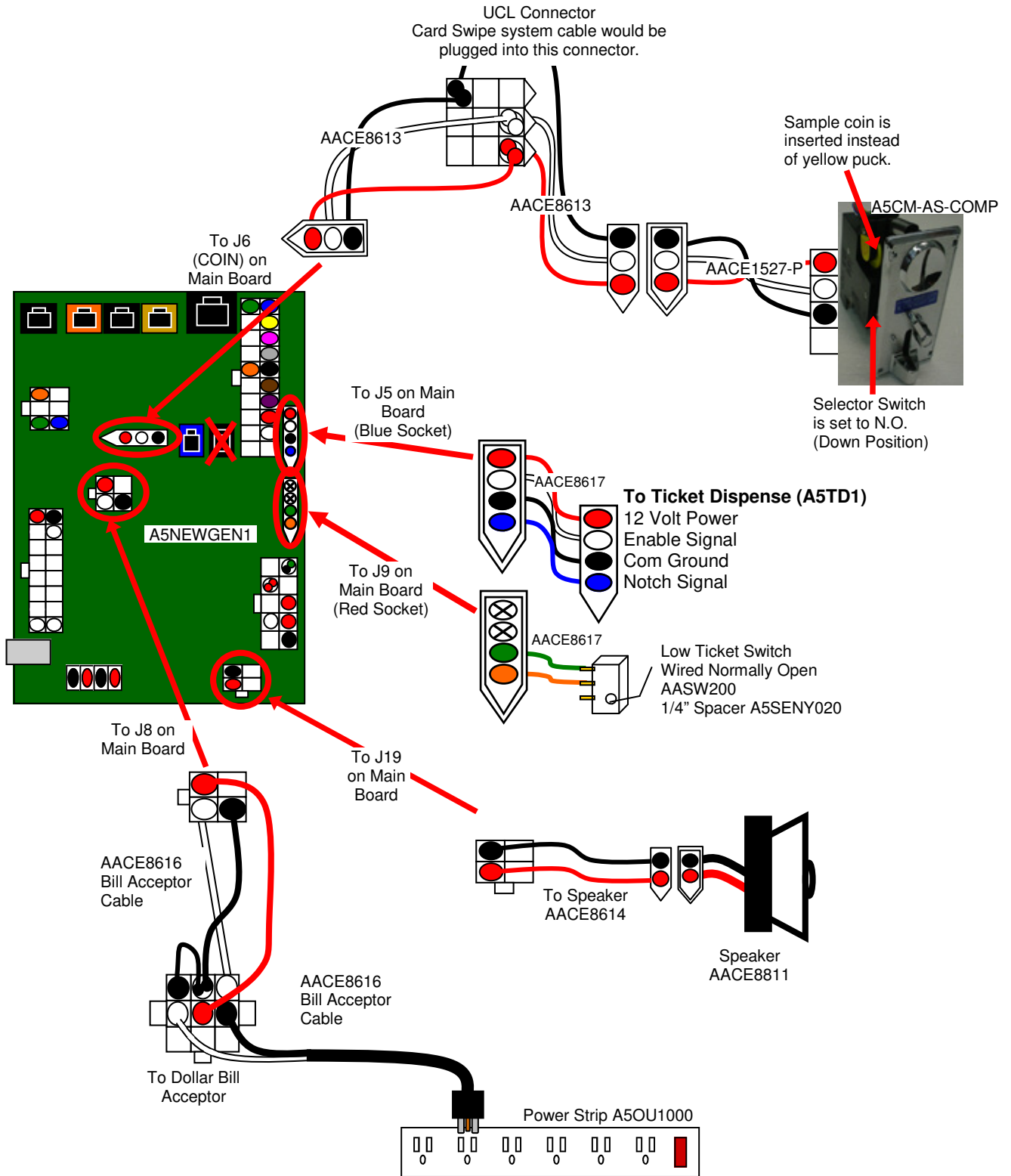

WIRING DIAGRAM

MENU BUTTONS, COUNTERS & MARQUEE LIGHTING

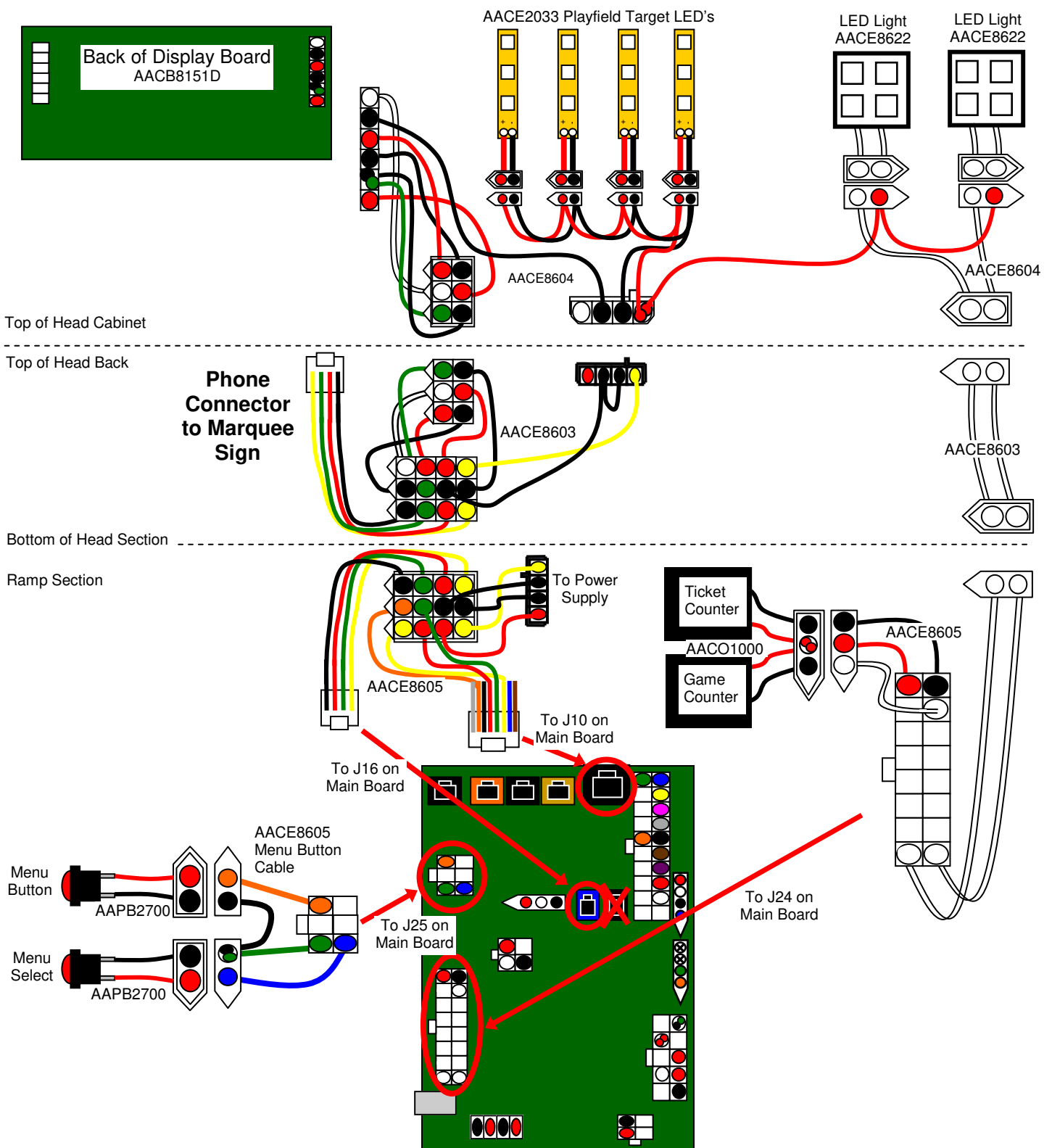

TROUBLESHOOTING GUIDE

Problem	Probable Cause	Remedy
No power to the game.	Unplugged. Connector loose between head and ramp Power strip turned off, or plugs unplugged. Circuit breaker tripped. Line filter faulty. Bad or overloaded power supply.	Check wall outlet cable (A5CORD5-A) to line filter in back of game. (A5FI9010) Check connection between head and ramp. Check rocker switch on power strip. Ensure power cords are pushed up into power strip securely. Reset power strip breaker switch or building circuit breaker. Attempt to determine cause. Replace line filter. (A5FI9010) Refer to Power Supply Diagnostics
Bill Acceptor on, but everything else off. (Power Supply not ON)	Power supply unplugged. Rocker Switch on power supply is Off. Power supply shutting down because of 12 V overload. Faulty power supply.	Insure power supply is plugged into power strip. Make sure rocker switch is set ON. See power supply diagnostics to isolate bad component. A bad motor or 12 volt short would cause this. Refer to Power Supply Diagnostics section.
Chase lights on ramp do not flash.	LED strip faulty Faulty Cable Faulty Main Board	Unplug one strip from cable to see if both strips are bad or just one. Examine LED strip. (AALD8100) Check cables from LED strips to main board. (AALD8100, AACE8601) Replace main board. (A5NEWGEN1)
LED target cabinet lighting not working.	LED's to light up playfield receive 12 Volts DC from power supply through the cable going to back of the Game.	Check for proper connection from power supply to LED strips. Check continuity. (AACE8605, AACE8603, AACE8604, AACE2033, and A5PS1011) Refer to Menu Buttons, Counters & marquee Wiring Diagram section.
Left and right marquee lights not flashing.	Faulty Cable Faulty LED Faulty Main Board	Check for proper connection from main board to LED strips. Check continuity. (AACE8605, AACE8603, AACE8604, AACE2033) Swap LED from the other side to verify. Replace LED (AACE8622) Replace main board. (A5NEWGEN1)





TROUBLESHOOTING GUIDE

Problem	Probable Cause	Remedy
Dollar Bill Acceptor not functioning.	<p>Ensure bill acceptor has 110 Volts AC.</p> <p>Dirt or debris in acceptor slot.</p> <p>Ensure acceptor dipswitch is set to "always enable"</p> <p>Pinched, broken, or disconnected wiring.</p> <p>Bill acceptor problem.</p>	<p>Acceptor should cycle stacker at game power up. If not, check cable connections to power strip. Caution – 110 Volts AC</p> <p>Clean with bill reader cleaning card. (A5CC9000)</p> <p>There are dips on side of acceptor. Set to "always enable" (not harness enable)</p> <p>Check wiring from bill acceptor to main board. Repair or replace wiring harness. (AACE8616)</p> <p>Refer to troubleshooting section of dollar bill acceptor manual included with this game or the diagnostics label of the back of the unit.</p>
No Audio	<p>Volume too low.</p> <p>Loose wire.</p> <p>Faulty Main Board</p>	<p>Increase the volume by pressing Menu button, to "Game Volume"</p> <p>Check audio cable connections from main board to speakers. (AACE8811, AACE8614, A5NEWGEN1)</p> <p>Replace Main Board. (A5NEWGEN1)</p>
Display not working	<p>12 Volt power In is missing.</p> <p>Communication cable issue.</p>	<p>Check cables from display board to power supply. (AACE8604, AACE8603, AACE8605, A5PS1011)</p> <p>Reseat J10 cable on main board. (AACE8605) Check other cables in series. (AACE8604, AACE8603) Replace display AACB8151D if needed.</p>
<p>Game does not coin up</p> <p>Game should have an audio track sound from speakers when coin switch triggered.</p>	<p>Check selector switch on coin comparator.</p> <p>Comparing coin is not set in place</p> <p>Pinched, broken, or disconnected wiring.</p> <p>Faulty Coin Mechanism. Take coin mech to different game to verify.</p> <p>Check Power In to Main Board</p> <p>Faulty Main Board</p>	<p>It should be down. (set to N.O. position)</p> <p>A coin that is the same as what your location uses should be inserted in the spring loaded mechanism of the coin mech.</p> <p>Check connections from coin switches to "Coin" connector on main board. Check continuity on wires. (AACE1527-P, AACE8613)</p> <p>Replace coin mech if faulty. (A5CM-AS-COMP)</p> <p>Check connections from power supply to main board. Check continuity on wires.(AACE8608) Refer to Power Supply Diagnostics section. Replace main board. (A5NEWGEN1)</p>

TROUBLESHOOTING GUIDE

Symptom	Probable Cause	Remedy
Tickets do not dispense.	Ticket tray empty due to faulty low ticket switch or broken/ loose wires. Switch stuck or switch wire bent out of position. Faulty cable to dispenser. Dirty opto-sensor or paper dust buildup in ticket dispenser Notch on tickets too shallow. Ticket dispenser faulty. Main circuit board malfunction.	Fill ticket tray. Replace low ticket switch(AASW200). Repair wiring. Clean ticket tray of dirt, loose tickets or debris. Bend switch wire to correct position under tickets. Check wiring continuity from dispenser to main board (AACE8617) Check for pinched, broken or disconnected wires. Replace as necessary. Clean with compressed air and if necessary wipe sensor with isopropyl alcohol on a cotton swab. Flip tickets and load upside-down to have large cut notch toward opto sensor. Replace dispenser with spare working dispenser (A5TD1) Replace main board if possible to isolate the problem to the main circuit board. (A5NEWGEN1)
Wrong number of tickets dispensed.	Ticket Pattern set wrong. Dirty opto-sensor on ticket dispenser. Notch on tickets cut too shallow. Faulty ticket dispenser. Main circuit board malfunction.	Enter menu and verify correct settings for Ticket Pattern Clean with compressed air or wipe with isopropyl alcohol on a cotton swab. Flip tickets and load upside-down to have large cut notch toward opto sensor. Replace with spare working dispenser (A5TD1). Swap cable from one output on main board to the other to verify cable/dispenser problem or faulty main board. (A5NEWGEN1)
Low tickets Red lines above and below the display 	Stack of tickets not resting properly on low ticket switch. Faulty switch. Faulty wire or connection. Faulty main board.	Adjust stack of tickets so they hold both the switch actuators down. Replace low ticket switch. (AASW200) Check for proper connection from switch to main board. Check continuity. (AACE8617) Replace main board. (A5NEWGEN1)
Game scores wrong	Game starts with a score already on display or scores double points.	Sensor is defective under score hole. Play game slowly to check sensors. Swap or replace defective sensor.(AACB3850A)

TROUBLESHOOTING GUIDE

Problem	Probable Cause	Remedy
<p>Balls are not released.</p> 	<p>Ball release solenoid sticking.</p> <p>AC Driver Board defective.</p> 	<p>Check for free movement of assembly. Check for 110 VAC pulse at solenoid.</p> <p>Check for green LED pulse on driver board when balls are supposed to be released. If pulse ok: Replace fuse located in small box on AC driver board. (A5FUSE3) Replace AC Driver board. (AABD5029) If no pulse, check wires from AC driver to main board. Replace main board. (A5NEWGEN1)</p>
<p>Too many balls are released.</p>	<p>Sensor at ball release blocked, dirty, or faulty.</p> <p>Pinched, broken, or disconnected wiring.</p>	<p>Clean sensor. Green LED should only come on when blocked. Replace if needed. (AACB3850A)</p> <p>Check connections from sensor board to main board. Check continuity on wires.</p>
<p>Not enough balls are released</p> <p>Game is waiting for player to throw balls and there are none left in track.</p>	<p>Ball count opto sensor is defective. </p> <p>Opto sensor at ball release is defective.</p>	<p>If this sensor misses a ball, the game will continue waiting until game time-outs. Replace sensor. (AACB3850A)</p> <p>If this sensor “sees” 2 balls instead of one. Replace sensor. (AACB3850A)</p>
<p>Meters do not work.</p> <p>Game counter clicks at end of each game.</p> <p>Ticket counter clicks as tickets come out of game.</p>	<p>The 2 wires crimped together may be faulty</p> <p>Pinched, broken, or disconnected wiring</p> <p>Main board faulty.</p>	<p>Inspect crimp to ensure good connection.</p> <p>Check connections from counters to main board. Check continuity on wires. (AACO1000, AACE8605)</p> <p>Replace main board. (A5NEWGEN1)</p>
<p>Menu Buttons do not work.</p>	<p>Swap connectors at the 2 buttons.</p> <p>Pinched, broken, or disconnected wiring</p> <p>Main board faulty.</p>	<p>Replace button if problem stays with button. (AAPB2700)</p> <p>Inspect crimp to ensure good connection. Check connections from menu buttons to main board. Check continuity on wires. (AAPB2700, AACE8605)</p> <p>Replace main board. (A5NEWGEN1)</p>

JACKPOT SIGN TROUBLESHOOTING GUIDE

Problem	Probable Cause	Remedy
No power to the sign.	Unplugged. Circuit breaker tripped Bad power supply.	Check wall outlet to line filter in back of sign. (A5FI9010) Reset power strip breaker switch or building circuit breaker. Attempt to determine cause. Fan on Power Supply should be turning. If not - check rocker switch on power supply. Replace Power Supply (AAPS1011-SBC/SS) If fan is turning on Power Supply, check cables that plug into the Power Supply.
Chase lights on sign do not flash.	LED strip faulty Faulty Cable Faulty NewGen Board	The 12 volt white LED rope light should be ON all the time. The 12 volt red LED rope light will flash for win. Check cables from LED strips to NewGen Board.(ACE8636) Replace NewGen Board. (AANEWGEN1)
Rear LED cabinet lighting not working.	Faulty Cable LED strip faulty	Check for proper connection from LED strip to power supply. Check continuity. (ACE8635, AAPS1011-SBC/SS) Replace LED strip. (ACE8635)
LED's lighting up left & right sides not working. LED's should be ON all the time.	Faulty cable wire or connection Faulty LED light strip.	Check for proper connection from LED's to power supply. Check continuity. (ACE6930, ACE8626, ACE8627, AAPS1011-SBC/SS) Replace LED light strip. (ACE6930)
Display Boards not working	No 5 Volts to Display Faulty Cable Display Board faulty	Check power supply connector and ensure 5 volts is going to display board. Check for proper connection from Display to NewGen Board. Check continuity. (ACE8630, AAPS1011-SBC/SS) Swap the 2nd board into the 1st location to determine if display board is faulty. Replace if needed. (AACB8151D)
Game is not incrementing sign. No communication to alleys.	Faulty cable wire or connection Faulty Board.	Check for proper connection from ACE8603 cable from alley to the sign. Position #1 and Position #2 must always be used. Up to 8 alleys can be plugged into AACB2205-D board. Swap this cable from one game to the next to verify alley issue. Check ACE8629 cable to AACB2205-D board. Check ACE8632 phone cable from Newgen to AACB2205-D board Replace AACB2205-D board or A5NEWGEN1 board.

BILL ACCEPTOR DIAGNOSTICS

Note: There are many different models and brands of Bill Acceptors that are used on redemption games. Your Bill Acceptor may differ from the unit shown.

Standard DBA is MEI # AE2451-U5E Part # A5AC9091 Installed upside-down on front door.

Determine if Bill Acceptor has power:

Turn game ON—The bill acceptor should make noise as stacker cycles and green lights on outside bezel should flash.

If NO power:

Use meter to measure 110 AC voltage at cable going into Bill Acceptor from power strip.

If power is OK:

Clean Bill Acceptor path to make sure there is nothing jamming unit.

Check dipswitch settings on side of acceptor.

Make sure switch # 8 is OFF for Always Enable

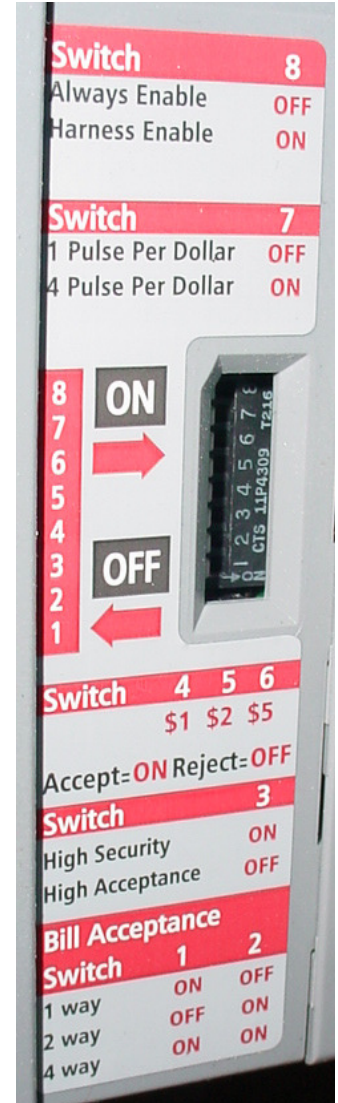
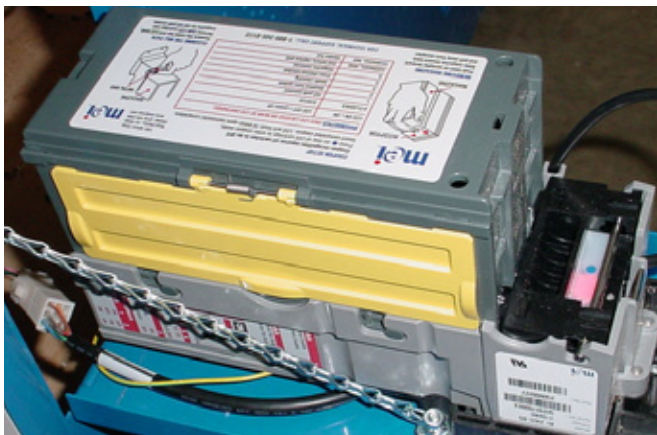

ERROR CODES

Count the number of flashes on front bezel of Bill Acceptor and follow chart for repair.

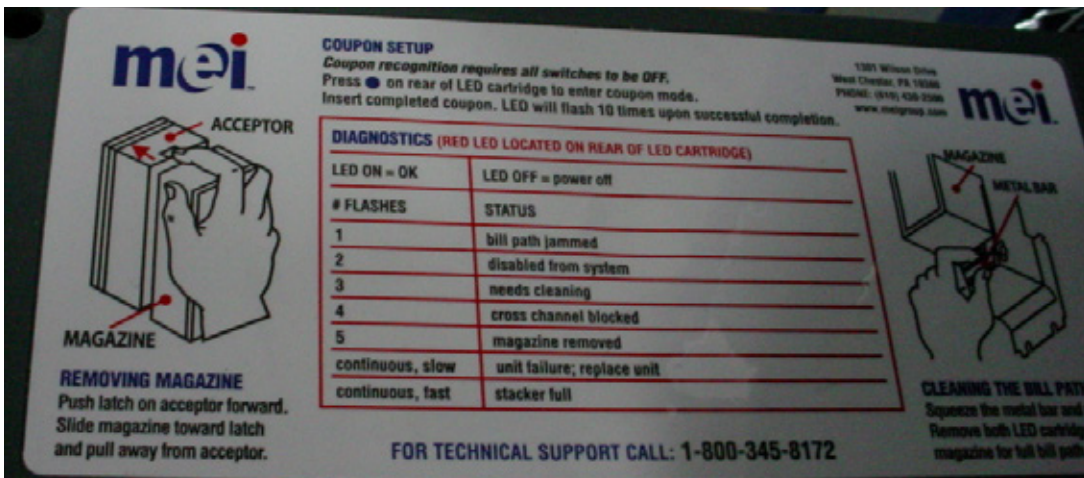

POWER SUPPLY DIAGNOSTICS

1.) Verify AC power to front of game. Check power strip in bottom front.
Check for illuminated power switch.

2.) Check AC power connection to power supply.

3.) Ensure Power Supply switch is set to 115V (or 230V)
(Some model power supplies may not have this)

4.) Ensure Power switch is on.

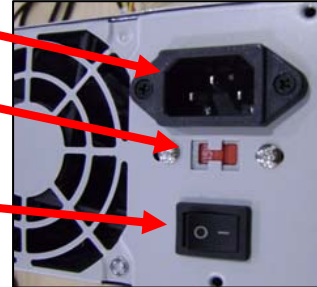

No 12 Volts (Power Supply Fan is not turning), but AC to power supply is OK

This means that either:

1.) Power supply is faulty.

2.) There is a 12 volt short in cabinet causing power supply to remain off to protect itself.

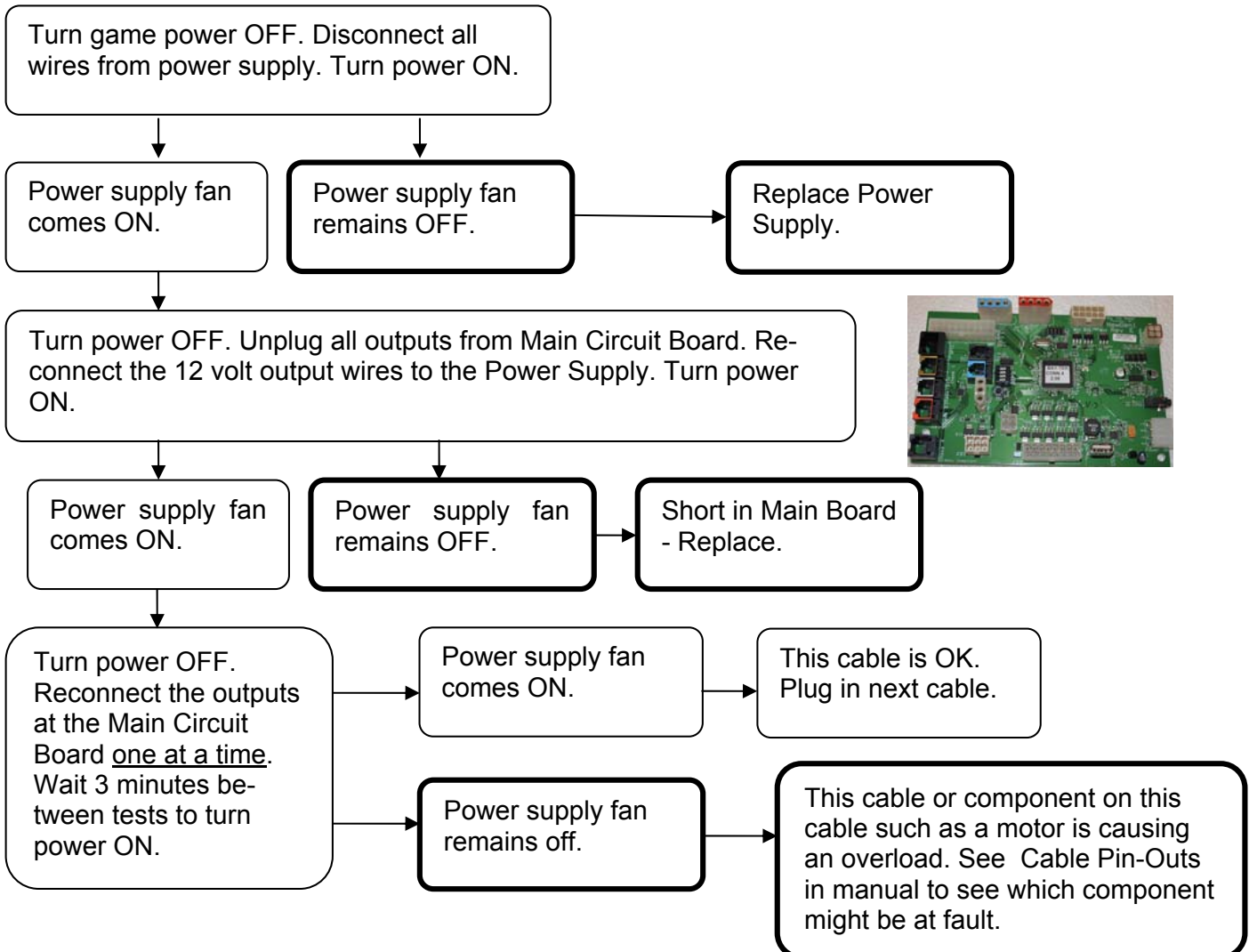

HOW TO: UPDATE SOFTWARE

Needed for Software Update:

One USB stick for MiniGen board

Installation Instructions:

Overview – This software upgrade consists of loading the software onto the NewGen Board.

MiniGen Software loading - NOTE: Game power must remain ON for this procedure.

1) Locate the USB stick with the MG designator for MiniGen Board.

2) Access the Minigen main board on bottom front of game. Behind locked door where speaker is located.

3) Insert the USB stick into the main board controller as shown here:

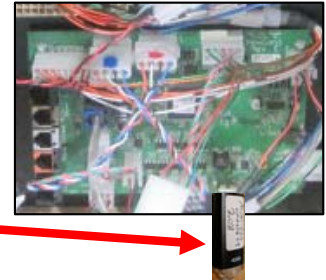

4) To trigger your file to load, press the small pushbutton next to the dipswitches.

NOTE: The file will load quickly; you will notice that the USB stick will flash, audio will reset after about 1 second, and the game will return to normal operating condition.

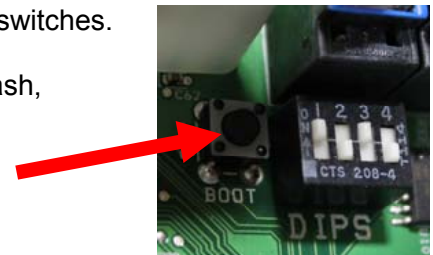

If you have any questions or need further assistance please contact Bay Tek Games. You may reach our Service Team at 920-822-3951 ext. 1102

HOW TO: SET FREE PLAY

The SkeeBall Game can be set up for home use, or for free play with the use of a separate front door switch plate.

Part # AAPB8625

This is installed in the same location as the coin mechanism in a regular game.

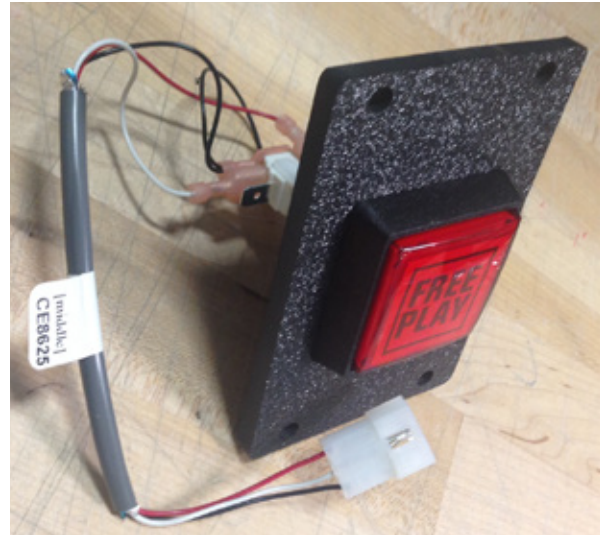

The dipswitches on the main board can be configured so that tickets will not be displayed, and game credits are cleared if the button is pressed many times.

Turn off game.
Move Dips #3 and # 4 to ON.
(The upward position)

Turn on the game.

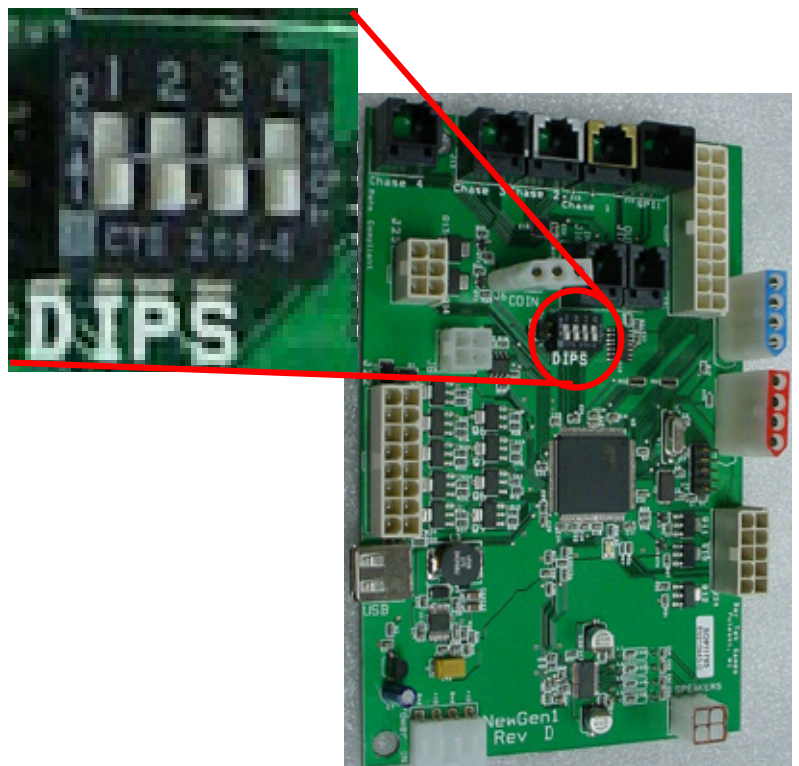

PARTS LIST

Part Number	Description	Part Number	Description
A5BA8106	3" Brown Ball	A5ME8616	Metal Coin Door Frame
W5TM1118	Yellow T-Molding (Sold Per Foot)	A5ME8617	Metal Plastic Cage Bottom Bracket
AACO1000	Counters	A5ME8618	Metal Plastic Cage Top Bracket
AATA2001	Ramp Cover Silver Decal (5ft each)	A5ME8619	Metal Ticket Tray Frame
AACM-AS-COMP	Coin Comparator with Cable	A5ME8620	Metal Cash Box
AACE1527-P	Coin Comparator Cable, Large Connector	A5CORD5-A	AC Computer Cord
AACE1527	Coin Comparator Cable, Small Connector	AACE2033	15" Light LED Cable
A5WR3800	5/16" Allen Wrench	AACE8600	Playfield Cable
A5LA3850	Receptacle End Latch	AACE8601	Ramp Light Power Cable
A5LA3851	Panel Fastening Latch	AACE8602	Ramp Power Jumper Cable
A5CA2100	Cam for A5LK2000	AACE8603	Lower Display Jumper Cable
A5LK2001	A05 Lock and Keys	AACE8604	Upper Display Jumper Cable
A5LK5002	H95 Lock and Keys	AACE8605	Power to Head/Ramp Cable
A5FI9010	In Line Filter	AACE8608	NewGen1 Power Cable
A5OU1000	Outlet Strip	AACE8609	Ball Switch - Aux Driver Board Cable
AASW200	Low Ticket Switch	AACE8610	Front/Back Target Cable
A5SL3851	Extendable Door Glides	AACE8611	Aux Driver Power Cable
AABK1013	Push Button/Counter Bracket	AACE8612	AC Driver to Solenoid Cable
A5HA3850	Handle for Cashbox	AACE8613	Coin Door Cable
A5KN8100	Black Knob	AACE8614	Speaker Cable
A5KP8100	19" Rubber Kick plate	AACE8615	Line Filter Cable
A5PL4200	DBA Plate	AACE8616	DBA Cable
A5PL8900	Blanking Plate	AACE8617	Ticket Tray Cable
AABA8100	Small Sand Bag (50 POINT)	AACE8618	Tier Opto Cable
AABA8101	Medium Sand Bag (40 POINT)	AACE8619	Rack Jumper Cable
AABA8102	Large Sand Bags (30 POINT)	AACE8621	Left Side Ground Cable
AABA8100-SET	SkeeBall Sand Bag Set	AACE8622	Head Light Cable
A5HO8100	Ball Hop	AACE8623	Playfield Jumper Cable
AACA8101	Ramp Cork Assembly (Green) 7' 6"	AACE8624	Right Side Ground Cable
AACA8102	Backboard Cork Assembly (Green)	AAPB2700	Red Push Button - Menu and Select
AACA8103-L	Left Ball Deflector Cork Assembly (Green)	AACE8811	Speaker Assembly
AACA8103-R	Right Ball Deflector Cork Assembly (Green)	AALD8100	63" Ramp Flex LED Cable
AACA8104	Playfield Cork Assembly (Green)	AASO1001	Solenoid
A5MO8100	Vibration Mount For Display	AABR3850	Ball Release Assembly
A5ME2020	Metal Ball Release Linkage	AAPS1011-SBC	Power Supply
A5ME3857	Metal Ball Release Top Plate	A5TD1	Ticket Dispenser
A5ME2013	Metal Ball Release Plunger	A5AC1004	Acrylic Driver Board Cover
A5ME3859	Metal Ball Release Plate	A5DE0042	Menu/Volume Pot Decal
A5ME8107	Metal Mesh Side Cage (2 Per Game)	A5DE8600	Marquee Plexi
A5ME8109	Metal Front Weldment	A5DE8601	Back Panel Decal
A5ME8123	Metal Rear Carpet Clamp	A5DE8602	Instructions Decal
A5ME8131	Metal Obstacle Rod (2 Per Game)	A5DE8603	Decals Number Set For Rings (Screw on)
A5ME8603	Metal Ball Bracket	A5DF8604	Tickets Decal
A5ME8606	Metal Carpet Clamp	A5DE8605	Internal Set Decal
A5ME3871	Front Ramp Hinge	AACB2203A	Scoring Sensor
A5ME8611	Metal Left Front Ticket Door	AACB3850A	Ball Track Sensor
A5MC8612	Metal Coin Door Cover (Silver)	AABD5029	AC Driver Board
AAME8613	Metal Right Ramp Cover With Decal	AABD5029V	220V AC Driver Board
AAME8614	Metal Left Ramp Cover With Decal	AACB8151D	Tricolor Display with Filter Board
A5ME8615	Right Coin Mech Door	A5NEWGEN1	New Gen1 Main Board

PARTS LIST

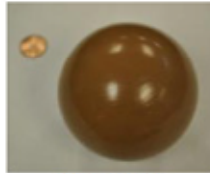

A5BA8106

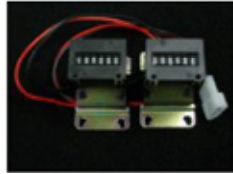

AACO1000



AATA2001

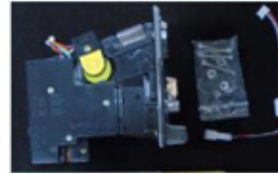

AACM-AS-COMP



AACE1527-P



AACE1527



A5WR3800



A5LA3850

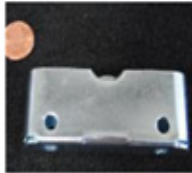

A5LA3851



A5LK2001



A5LK5002



A5F19010



A5OU1000

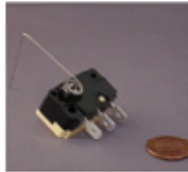

AASW200



A5SL3851



AABK1013

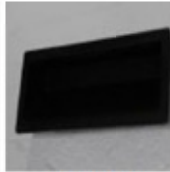

A5HA3850



A5KN8100



A5KP8100



A5PL4200



A5PL8900

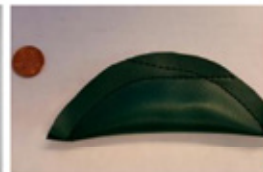

AABA8100



AABA8101



AABA8102

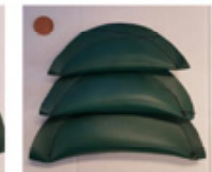

AABA8100-SET



A5HO8100



AACA8101



AACA8102



AACA8103-L



AACE8103-R



AACA8104



A5MO8100



A5ME2020

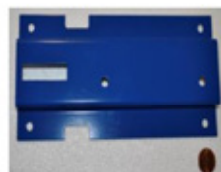

A5ME3857



A5ME2013

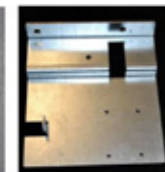

A5ME3859



A5ME8107



A5ME8109



A5ME8123



A5ME8131



A5ME8603



A5ME8606



A5ME8611

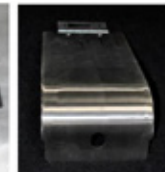

A5ME8612



AAME8613



AAME8614

PARTS PICTURES



A5ME8615 A5ME8616 A5ME8617 A5ME8618 A5ME8619 A5ME8620 A5CORD5-A

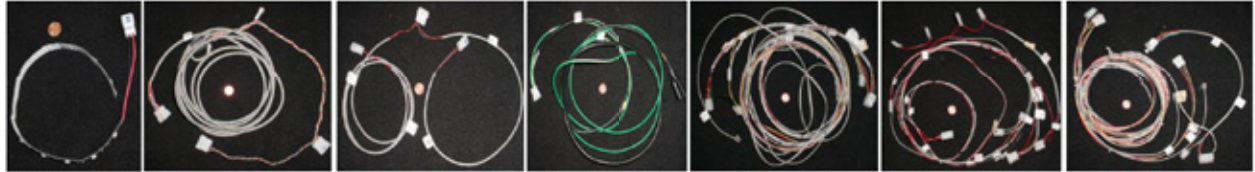

AACE2033 AACE8600 AACE8601 AACE8602 AACE8603 AACE8604 AACE8605



AACE8608 AACE8609 AACE8610 AACE8611 AACE8612 AACE8614 AACE8615



AACE8616 AACE8617 AACE8618 AACE8619 AAPB2700 AACE8811 AALD8100 AASO1001

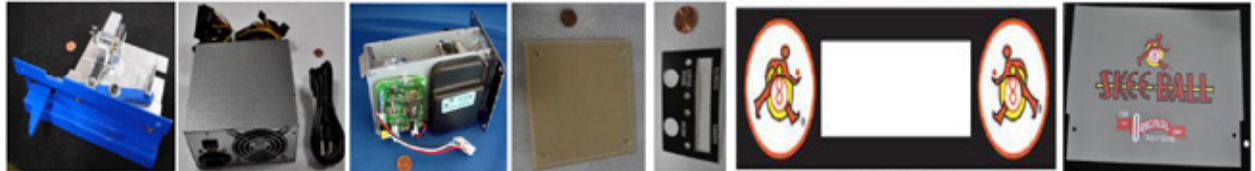

AABR3850 AAPS1011-SBC A5TD1 A5AC1004 A5DE0042 A5DE8600 A5DE8601



A5DE8602 A5DE8603 A5DE8604 AACB2203A AACB3850A AABD5029



AABD5029V AACB8151D A5NEWGEN1

GAME DECALS



JACKPOT SIGN A5NEWGEN1 PINOUT

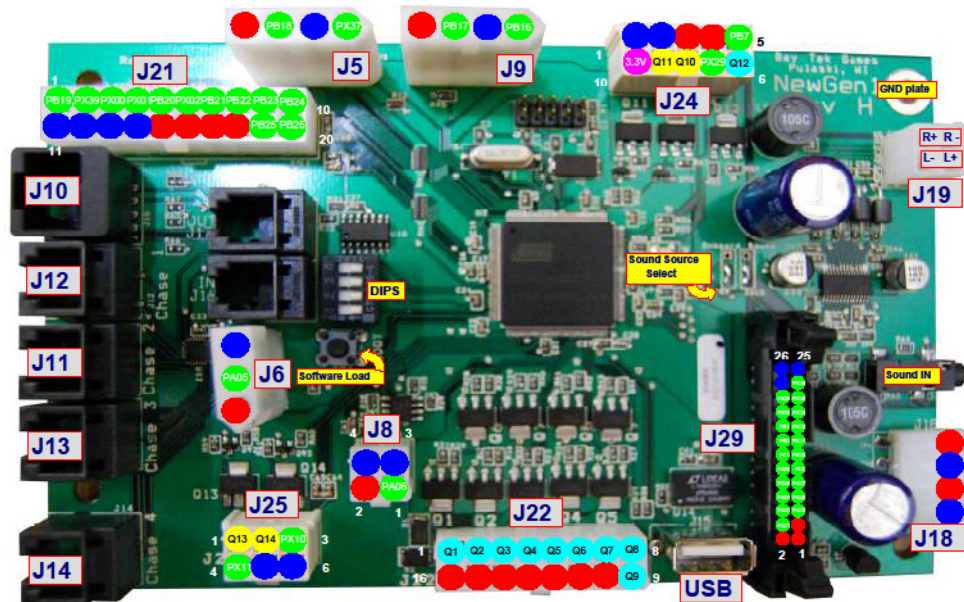
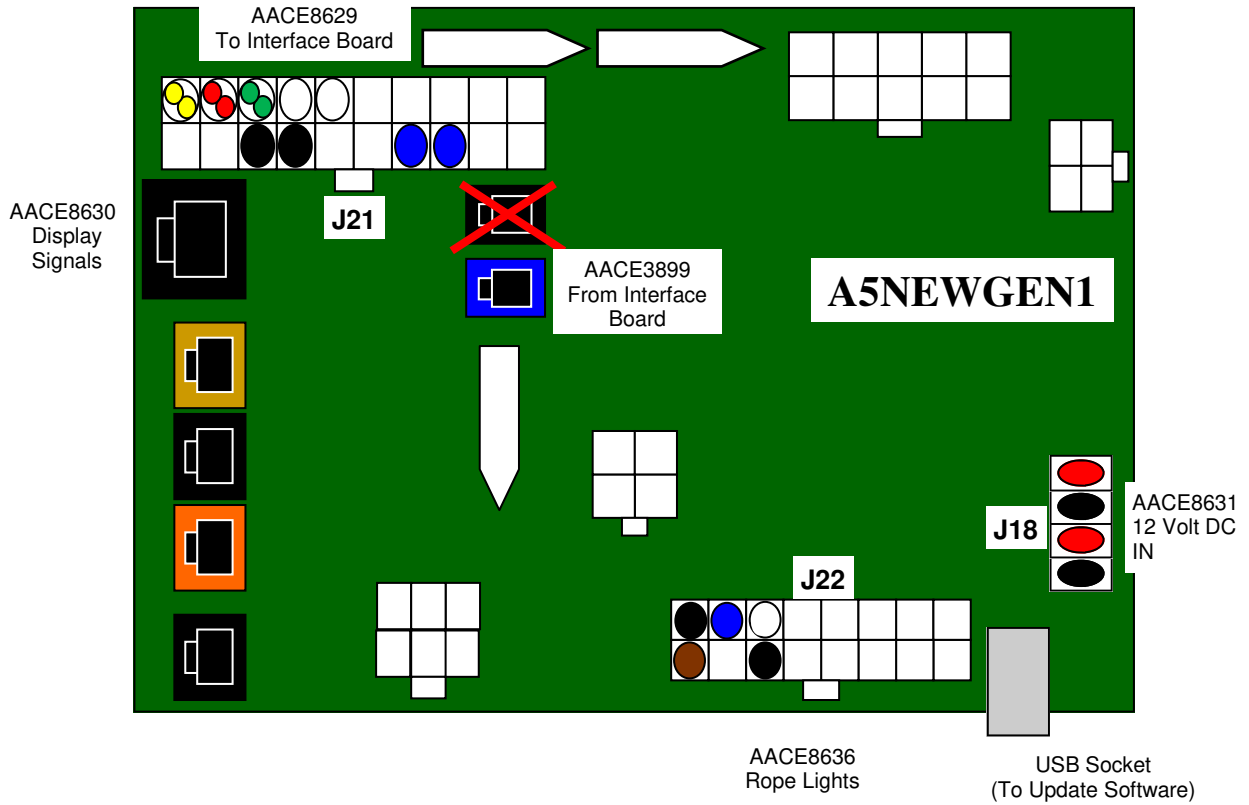

- Ground
- +12V
- Low Side Driver
- High Side Driver
- TTL Logic
- +3.3V

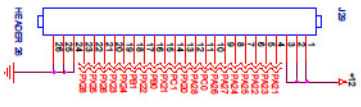

- SPI Out - Display - (J10)**
 - Pin 1 & Pin 3 - +12V
 - Pin 2 - SCLK_BUS2
 - Pin 4 - SMOSI_BUS2
 - Pin 5 & Pin 7 - Ground
 - Pin 6 - SCS2_BUS2
 - Pin 8 - SMISO_BUS2
- Chase Lights (J11,J12,J13,J14)**
 - Pin 1 - Chase Output
 - Pin 2 - Chase Output
 - Pin 3 - +12V
 - Pin 4 - Chase Output
 - Pin 5 - Chase Output
 - Pin 6 - +12V

MARQUEE WIRING DIAGRAM

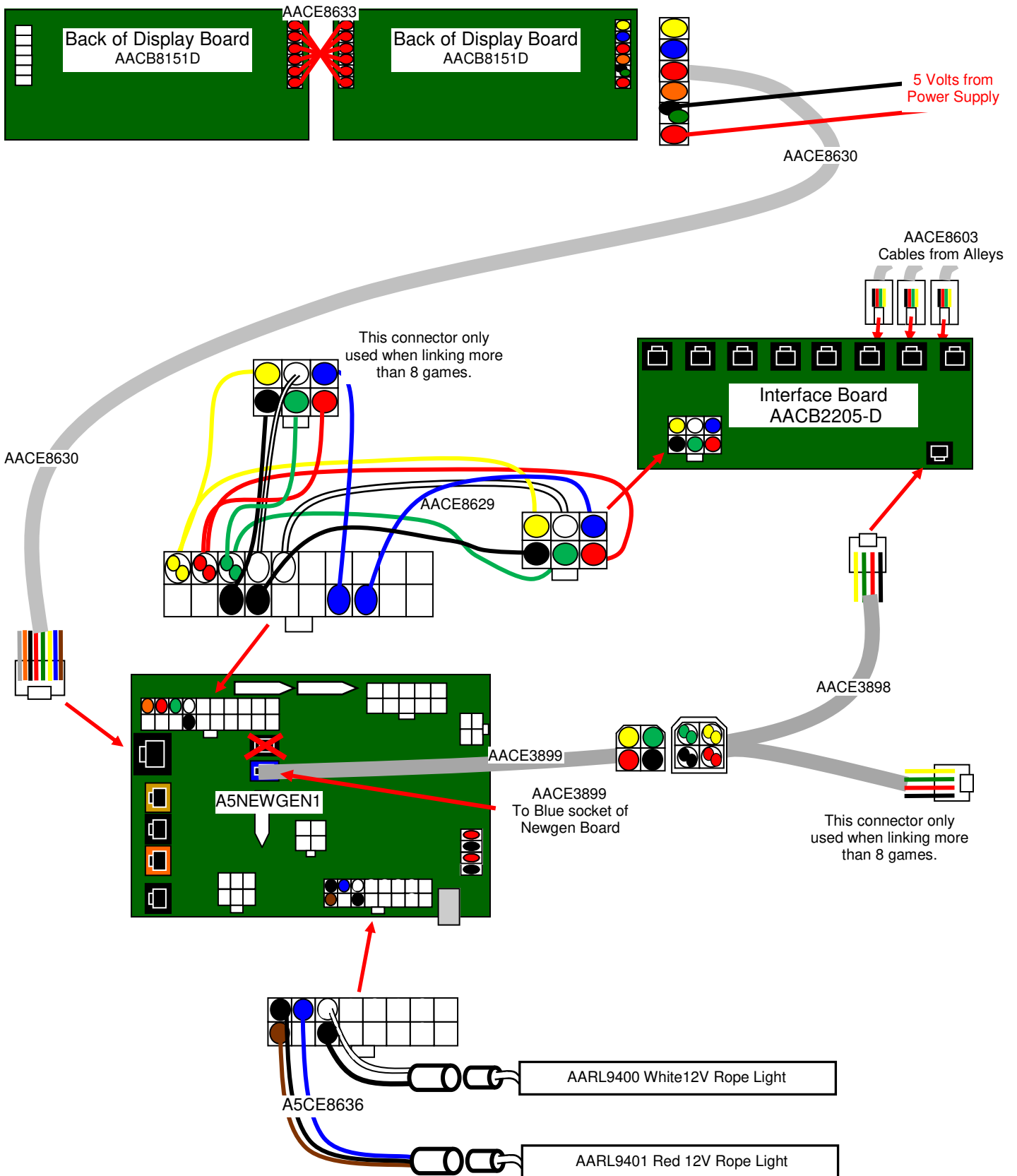

MARQUEE SIGN POWER WIRING DIAGRAM

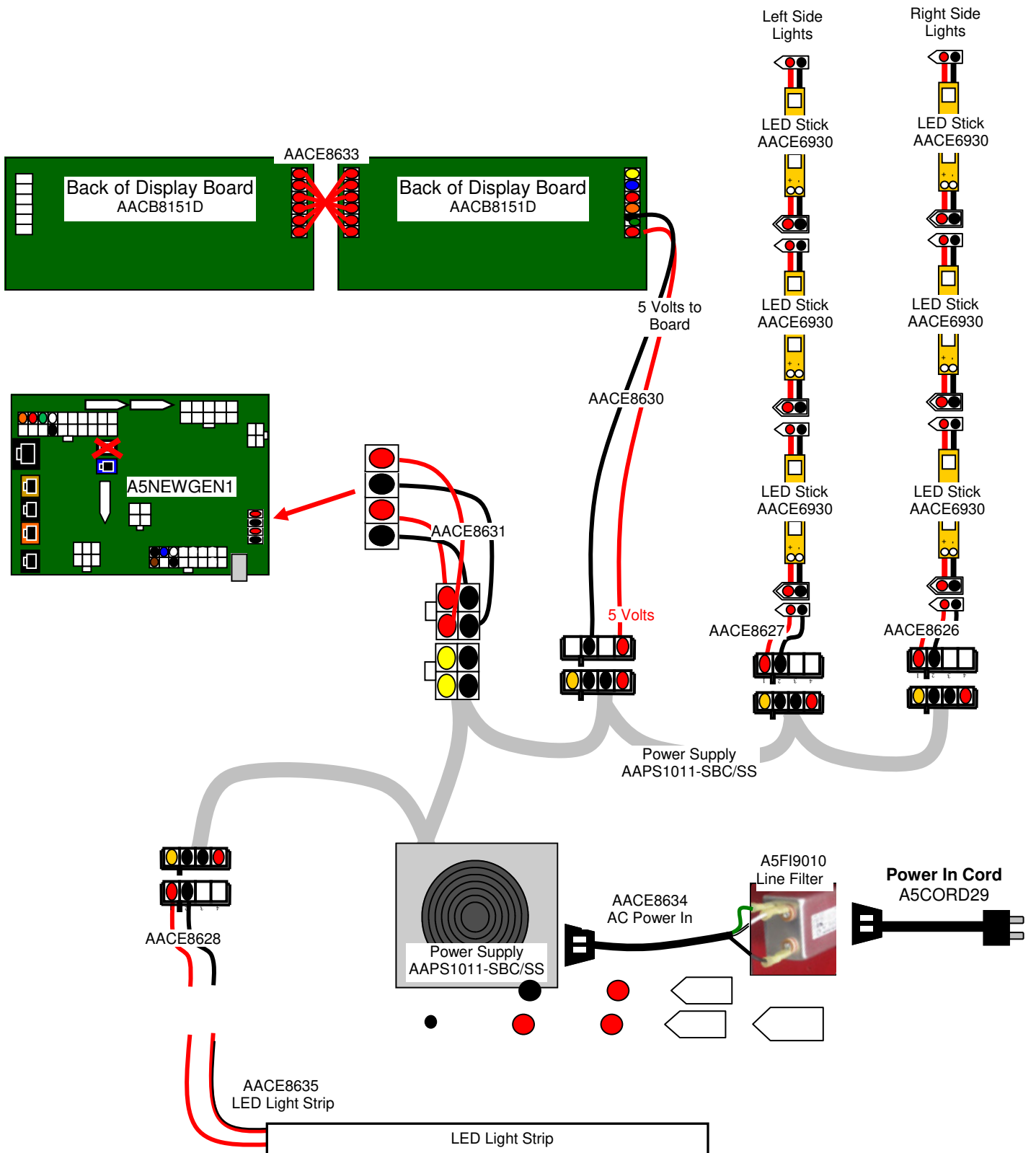

MARQUEE SIGN PARTS LIST

JACKPOT SIGNS

Part Number	Description
A5BK9999	Bracket, Power Supply Mounting
A5CORD29	Cord, 20'
A5DE8606	Decal, SkeeBall Jackpot
A5EB9000	Electrical Box
A5FI9010	Filter, F1700ca06, Inline
A5LK5002	Lock, 7/8", H95 Key Code
A5ME8143	Metal, Jackpot Stand Rh
A5ME8144	Metal, Jackpot Stand Lh
A5ME8145	Metal, Jackpot Mt Bracket
AACE6930	Cable, Marquee Stick Lights, 8 In,
AACE8626	Cable Assy, Marquee Rt Side Lights
AACE8627	Cable Assy, Marquee Lt Side Lights
AACE8628	Cable Assy, Marquee Long Light
AACE8629	Cable Assy, Marquee Gen 1 To Cb2205
AACE8630	Cable Assy, Marq Display Signal To Power
AACE8631	Cable Assy, Marquee Gen 1 To Power
AACE8632	Cable Assy, Marquee Gen 1 To Cb2205
AACE8633	Cable Assy, Marquee Display Jumper
AACE8634	Cable Assy, Marquee Power Cord
AACE8635	Cable Assy, Marquee Stick Light
AACE8636	Cable Assy, Marquee Rope Lights
AAPS1011-SBC/SS	Cable Assy, Marquee Power Supply
W5HG1035	Hinge,23",Double Bend
W5KE5000	Keeper, Lock
WARR0020-SBC10SIGN	Black HDPE Oval Sign
WARR0022-SBC10SIGN	Black ABS Sign
AACB8151D	PCB, Display, Tri Color
A5NEWGEN1	Main Board, New Gen 1
AACB2205-D	Cir Bd Assy, Prog Sign Interface

LINK KIT

Part Number	Description
A5BK9999	Bracket, Power Supply Mounting
A5KIT-LINKBOXES	Linking Kits, Hardware Kit
A5LK5002	Lock, 7/8", H95 Key Code
AACE3898	Cable Assy, Fusion, Grand Marq
AACE3899	Cable Assy, Fusion, Grand Marq
AACE8629	Cable Assy, Marquee Gen 1 To Cb2205
AACE8631	Cable Assy, Marquee Gen 1 To Power
AACE8637	Cable Assy, Super Shot Sign,
W5HG1045	Hinge,5.75" Double Bend
W5KE5000	Keeper, Lock
A5NEWGEN1	Main Board, New Gen 1
A5PS1011	Power Supply, Roswell Rv350-2
AACB2205-D	Cir Bd Assy, Prog Sign Interface

MARQUEE SIGN PARTS PICTURES

JACKPOT SIGN



A5BK9999



A5CORD29



A5DE8606



A5EB9000



A5FI9010

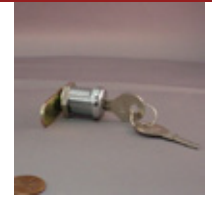

A5LK5002



A5ME8145



AACE6930



AAPS1011-SBC/SS

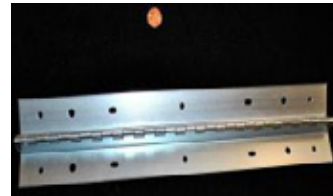

W5HG1035

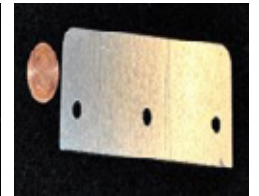

W5KE5000

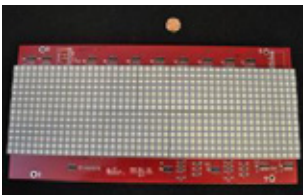

AACB8151D

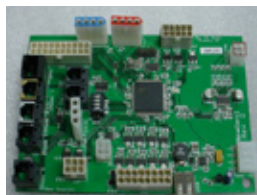

A5NEWGEN1

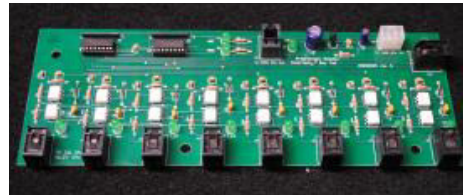

AACB2205-D

LINK KIT



A5BK9999



A5LK5002

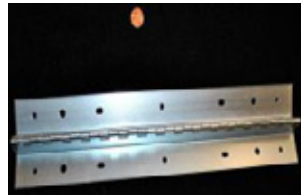

W5HG1035

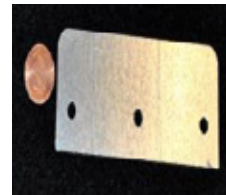

W5KE5000

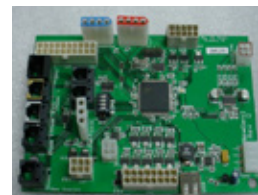

A5NEWGEN1



A5PS1011

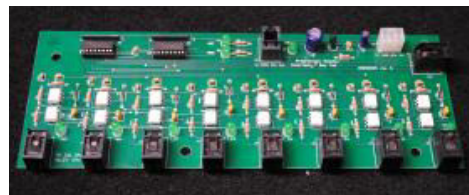

AACB2205-D

TECHNICAL SUPPORT

Excellent customer service is very important to Bay Tek Games!

We know that keeping your games in great operating condition is important to your business. When you need us, we are here to help. You can call us for free technical assistance, and you can count on us to have parts on-hand to support your game. We offer options that fit your needs.

Electronics / Circuit Boards - Repair Options

Repair & Return – If you have Circuit Board issues with your Bay Tek game, you can send the board to us and we'll repair it right away. Most items sent to us are repaired and returned to you within two days. This option is your best value as we offer this fast turn-around service at the most reasonable price.

Advance Replacement – If you have Circuit Board issues with your Bay Tek game, but you don't have time to send in your board in for repair, give us a call and ask for an Advance Replacement. We'll send you a replacement board that same day (pending availability). When you get your new board, just repackage the defective board in the same box and send it back to us. We make it easy by including a UPS Return Shipping label for you to put on the box (not available for international shipments). This is your best option when you need to get your game up and running as quickly as possible!

Spare Parts – Take matters into your own hands and purchase new spare Circuit Boards for your Bay Tek games. Many of our games share the same main-board electronics. This means you can buy one set of spare electronics to support many of your Bay Tek games. Spare boards allow you to get your game up and running the quickest and provide you a valuable troubleshooting option. Call our technicians to get recommendations for what you should keep on hand for spare parts!

Technical Support:

"You" are the best tool for troubleshooting! Your abilities to understand the game and your skills to repair the game are invaluable to us! If you need help, you know you can call us. It's not easy to diagnose a game remotely by phone, but our technicians do a great job. They'll need your help to perform some troubleshooting steps and convey to them exactly what's happening with your game.

Returns, Credits, & Fees:

NOTICE! ALL ITEMS being sent to Bay Tek Games for repair or return, etc. require prior Return Authorization! Bay Tek Games will provide a Product Return Form with an authorizing Ticket Number for each item to be returned. Please be certain to include this document with all shipments!

Late Fees and Non-Return Fees - Advance Replacement and Warranty Replacement items require the defective items to be returned by Bay Tek games promptly to avoid Late Fees. We expect items to be returned with 10 working days. Late fees are invoiced monthly. Late fees are non-refundable under any circumstance! Any item not returned within 90 days will be invoiced in full as a replacement part.

Bench Fees - Bench fees will apply for each electronic item returned to Bay Tek Games (this includes unused Advance Replacement items). This charge covers our cost to inspect, evaluate and retest each item. Please note that returned items that do not pass our tests will be charged accordingly as replacement items or advance replacements.

Restocking Fees - Unused items returned for credit will be credited minus a restocking fee. Items must be returned within 30 days of purchase in order to qualify for any credit amount. No shipping charges will be credited.

WARRANTY

Bay Tek Games warrants to the original purchaser that all game components will be free of defects in workmanship and materials for a period of 6 months from the date of purchase. If you fill out the registration card in the cashbox of the game, Bay Tek will add another 3 months to your warranty, free of charge.

Bay Tek Games will, without charge, repair or replace defective component parts upon notification to the parts/service department while the game is under warranty.

Warranty replacement parts will be shipped immediately, via ground service, along with a Product Return Form for the return of defective parts.

Defective parts must be shipped back to Bay Tek Games unless otherwise instructed. Items not returned to Bay Tek Games will be invoiced as replacement parts.

This warranty does not apply in the event of any misuse or abuse to the product, or as a result of any unauthorized repairs or alterations. The warranty does not apply if any serial number decal is altered, defaced, or removed from its original position.

 **ATTENTION** 

In order to maintain the safety & compliance certifications of this game, **ONLY** approved parts may be used. For approved replacement parts, refer to the parts list in this manual.

Should you need your game serviced, determine the serial number from the decal placed on the front of this manual, or locate it on the back of the game. Then contact our Service Department at: 920.822.3951 or e-mail: service@baytekgames.com

NON-WARRANTY

Options and estimated charges will be provided to you for your approval.

Please remember that any items being sent to Bay Tek Games must include prior return authorization from our Parts & Service Department.

This approval will include a Product Return Form which is required to be included with any incoming shipments. Repaired parts will be shipped back using the same method in which they were received.

Repairs are warranted for 30 days from the date of return shipment.