



C72

assembly
support manual

EN

Table of contents



General Information	05
C72 Frame-kit: List of parts	07
List of Recommended Tools and Supplies	10
Seatpost installation	12
Seatpost installation – seatpost cut	14
Saddle clamp installation	16
Front axle installation	18
UDH – Rear derailleur hanger installation	18
Front derailleur hanger installation	19
Fork and headset installation	20
Di2 Battery support assembly	26
Integrated bottlecage assembly	27
Brake hose routing	30
Electric - Di2 wire routing	32
Tire clearance	33
Intended Use for Colnago C72	34
Weight Limit	35
Torque and fasteners recommendation	36
Torque setting table	37
Colnago C72 - Technical Information	38
Colnago C72 - Geometry Chart	39

General Information

This manual is a guideline for the official Colnago retailers in the assembly and adjustment of the Colnago C72 bicycle. It assumes that the assembler is a well-trained professional bicycle mechanic, and, furthermore, it is not intended to replace any assembly and service instruction provided by third-party component manufacturers. If the pictures in the manual are presented to clarify the assembly procedure; real components might slightly differ from the ones in the pictures. This manual shows only the procedure associated with the installation of Colnago parts, as well as the routing of shifting and braking cables. All the Colnago proprietary parts listed below are available only through Colnago and/or its authorized distributors. Failure to use the specified parts and to follow these assembly instructions may lead to serious injury or death.

C72 frame-kit

List of Parts

The numbers shown in the diagram do NOT correspond to the Colnago spare part purchase codes

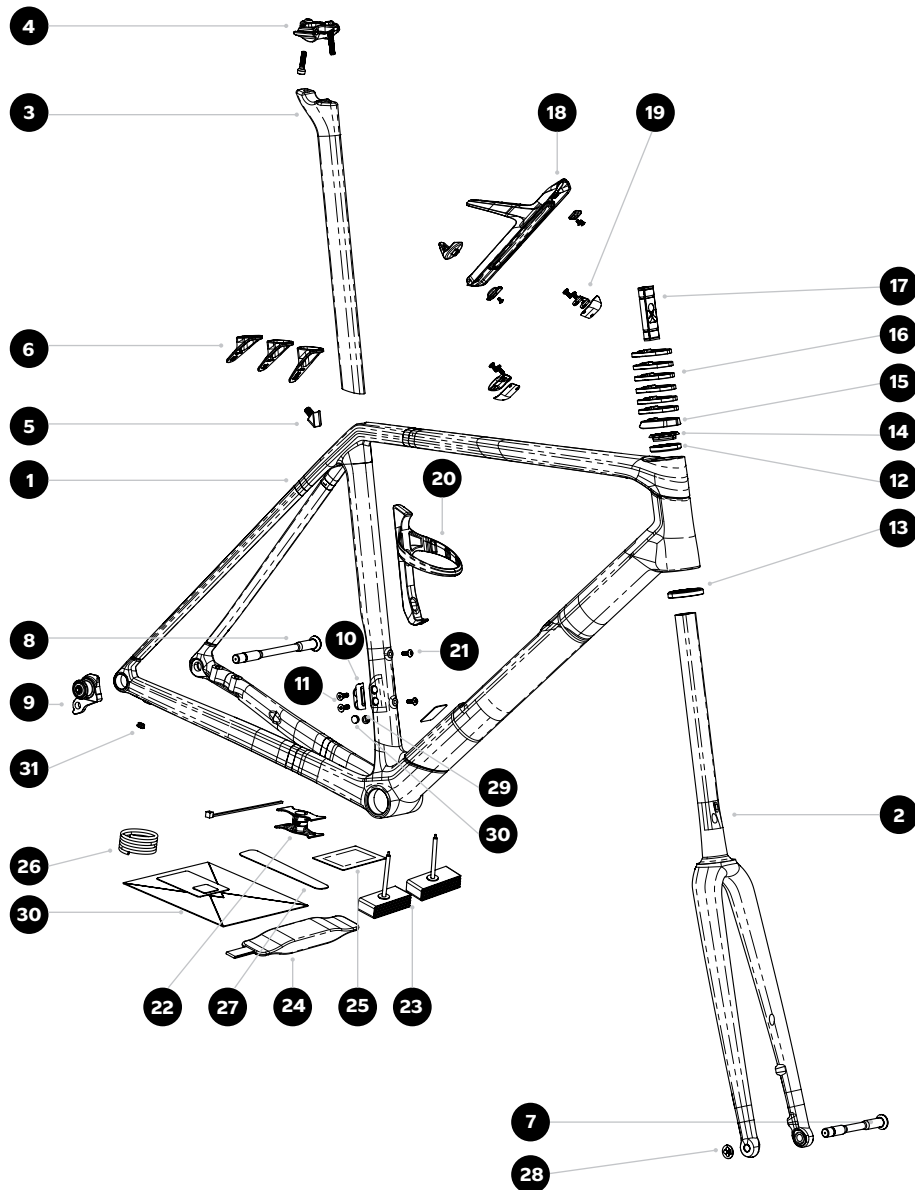

ITEM NO.	DESCRIPTION	QTY
1*	C72 - Painted Frame	1
2*	C72 - Painted Fork	1
3	C72 Seatpost - 15 mm offset	1
4	Colnago Seat Clamp kit - 2 bolts	1
5	C72 Seatpost Clamp	1
6	C72 Seatpost Rubber Grommet kit (3 pcs)	1
7	Threaded Thru-Axle UDH Front 12 mm	1
8	Threaded Thru-Axle UDH Rear 12 mm	1
9	UDH Hanger	1
10	Front Derailleur hanger	1
11	M5x15 Flat head screw - Colnago logo	2
12	CS - Upper Bearing 31x40x7 SLT	1
13	CS - Lower Bearing 35x47x7 SLT	1
14	C72 Compression Ring	1
15	C72-CC.02 Dust Cover	1
16	CC.02 Spacer 5mm open	6
17	D-Shape Expander	1
18*	Colnago custom carbon bottlecage DT w/storage box	1
19	Colnago custom bottlecage DT w/storage box - clamp	1
20	Colnago bottle cage carbon - std	1
21	M5X12 Socket head screw - low profile - Colnago logo	1
22	Di2-battery holder spider + zip tight	1
23	Tubolito S-Tubo 23/35-622 - 60mm	2
24	Colnago Storage case + tools + CO2 adaptor	1
25	Colnago Grease sample	1
26	Foam Hose Cover	1
27	Chain guard sticker transparent	1
28	Colnago front axle Sticker	2
29	Non-drilled rubber cap Di2	1
30	Drilled rubber cap Di2	1
31	CS rubber grommet Di2	1

CC.02 kit

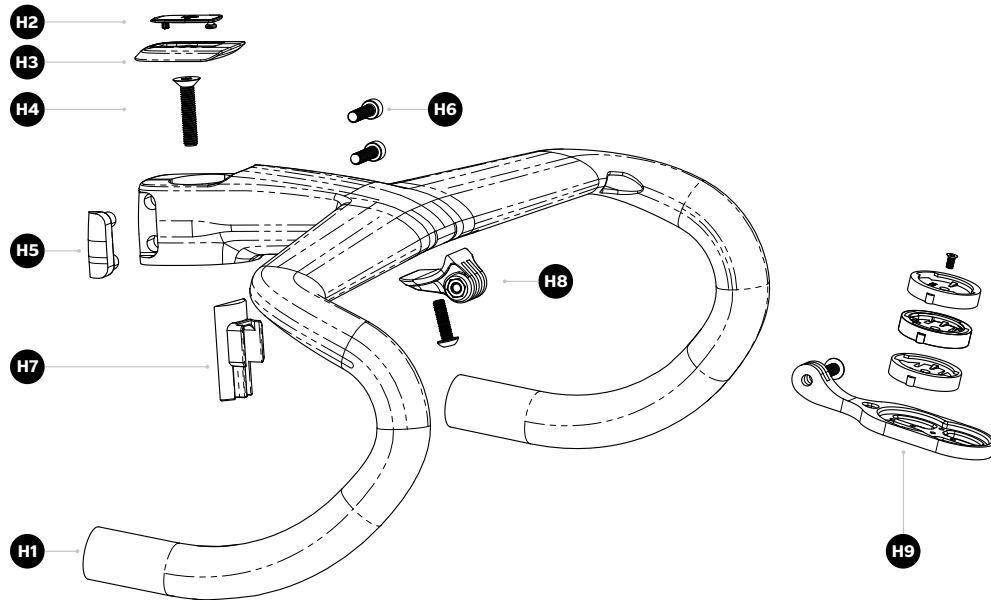







ITEM NO.	DESCRIPTION	QTY
H1	Colnago CC.02 integrated carbon cockpit	1
H2	CC.02 - top screw cover	1
H3	CC.02 - carbon forged top cap	1
H4	M6x30 flat head screw stainless steel/black	1
H5	CC.02 -rear alloy nut	1
H6	M5x20 socket head screw stainless steel/black/w + washers	2
H7	Plug D-Shape - self-centered	1
H8	Connection mount CC.01/CC.02	1
H9	Universal support arm	1

List of Recommended Tools and Supplies

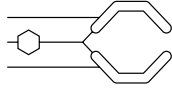
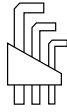
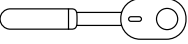
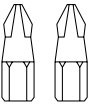
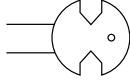
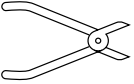
The following tools and parts listed are required for mounting and adjusting procedures of Colnago parts. Colnago recommends any intervention on the bike to be performed by an authorized Colnago retailer.

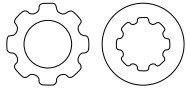
Refer to each specific mounting procedure and requirements for the assembly of a specific component, provided its own manufacturer.

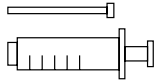
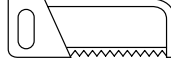
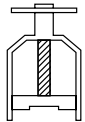
NOTE: If you are a Colnago C72 consumer/purchaser reading this manual, we suggest you consult your authorized Colnago retailer before undertaking any procedure in this manual.

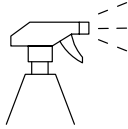
<p>Bike SupportStand</p> 	<p>Allen key key 2 ÷ 12 mm</p> 	<p>Torque wrenches with 2.5 Nm to 25 Nm</p> 
<p>Phillips and slot head screw-driver</p> 	<p>Pedal wrench</p> 	<p>Cable cutters</p> 
<p>Pliers</p> 	<p>Brake rotor locking tools (inner and outer)</p> 	<p>Di2 wire tool -Shimano</p> 
<p>Hydraulic bleed kit</p> 	<p>Hacksaw (with carbon blades)</p> 	<p>Saw cutting guide</p> 
<p>High quality grease & carbon assembly compound for bikes</p> 	<p>Isopropyl alcohol</p> 	

Seatpost installation

3	C72 Seatpost -15 mm offset
4	Colnago Seat Clamp kit - 2 bolts
5	C72 Seatpost Clamp
6	C72 Seatpost Rubber Grommet kit (3 pcs)

Step 1: Insert the C72 seatpost clamp (N. 5) into the seat tube, positioning it correctly in its housing. Secure the clamp to the frame by turning the clamp screw counterclockwise until it reaches the end of its thread.

Step 2: Insert the seatpost (N. 3) into the seat tube after fitting the correct C72 rubber grommet (N. 6) around it.

NOTE: Each C72 frame includes three different rubber grommets to properly match the various seatpost shapes and sizes. Select the correct one by checking the marking inside the grommet.

Step 3: After adjusting the saddle height, **tighten to 7 Nm** to prevent slipping. Then position the rubber grommet to cover and protect the rear screw.

NOTE:

Apply carbon compound both to the inner face of the seat tube and to the carbon seatpost. After installation, hold the frame and bicycle through a secured seatpost only. Clamping the top tube may cause damage and void the frame warranty.

Step 1

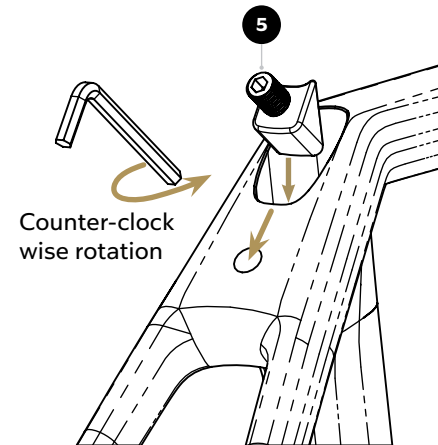

Step 2

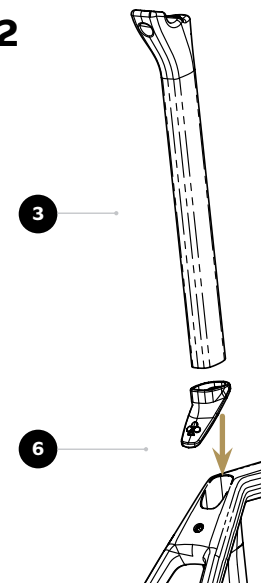

Step 3

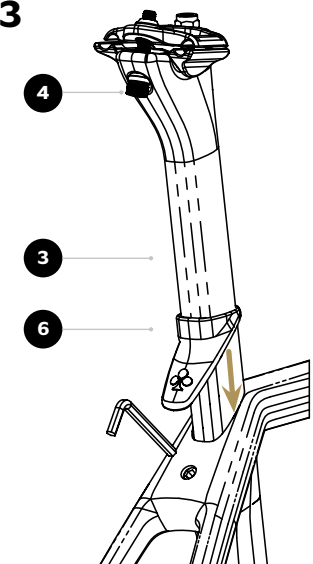

Seatpost installation

Seatpost cut

It is possible to cut the seatpost if it is too long. In this case:

- Use the proper tool to prevent carbon fiber delamination.
- Cut the seatpost at a 90° angle.
- Always maintain a minimum insertion depth of 90 mm

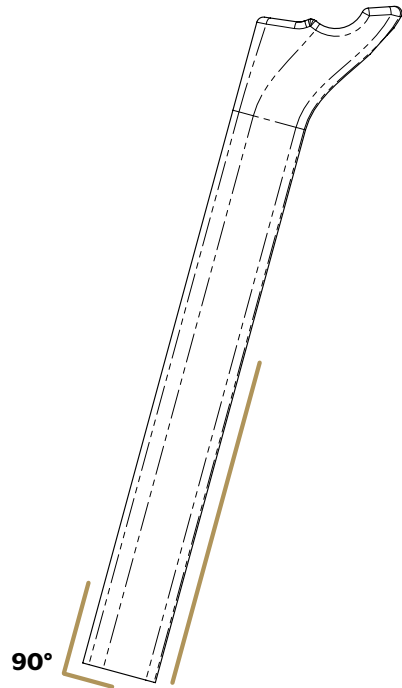

Colnago C72 features a seatpost stopper to prevent damage caused by excessive seatpost insertion. The stopper depth varies depending on the frame size. If the seatpost cannot be inserted any further, do not apply additional force. Instead, the seatpost must be cut to the appropriate length.

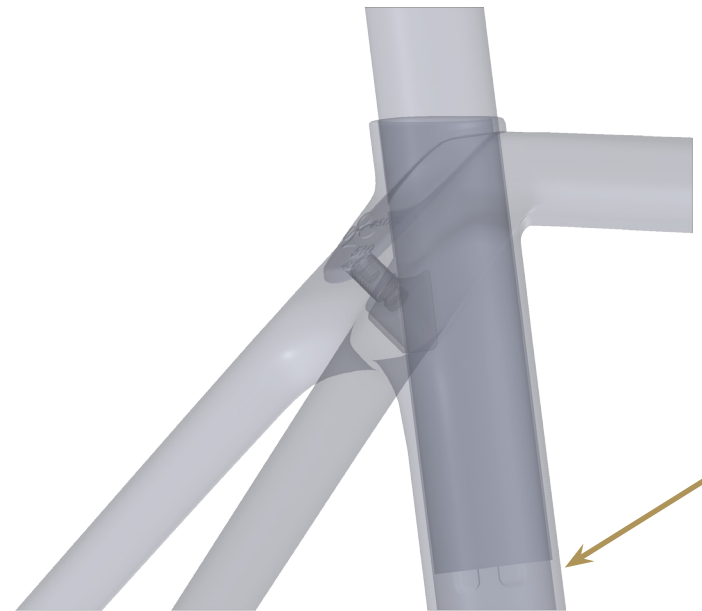

Saddle clamp installation

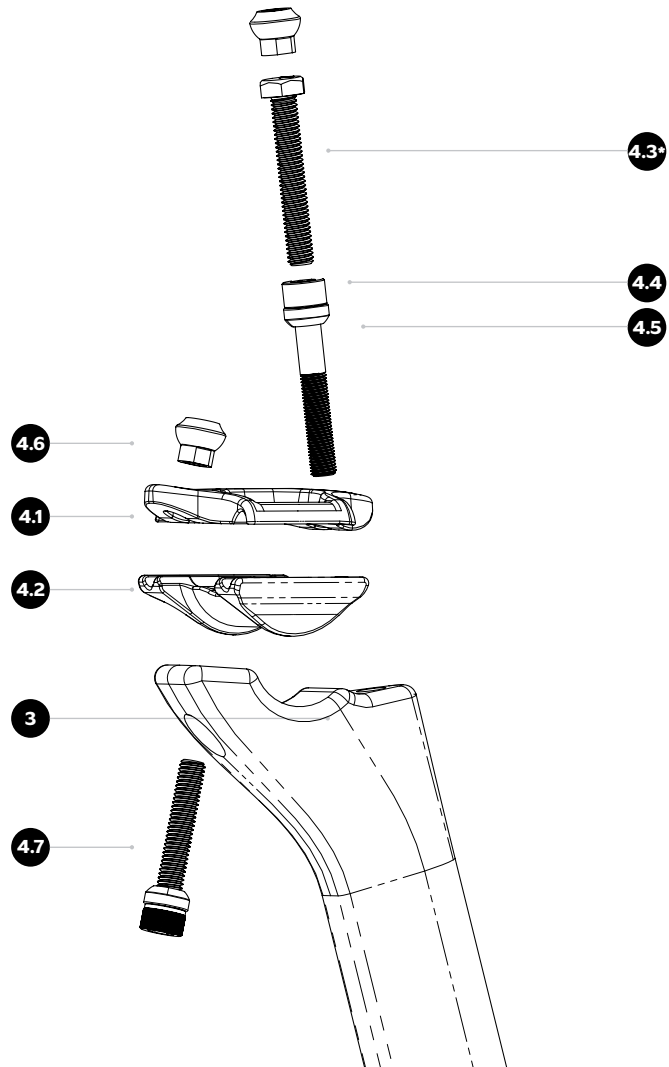

3	C72 Seatpost
4.1	Saddle Clamp - Top
4.2	Saddle Clamp - Bottom
4.3*	M6x40 Hex Head Screw
4.4	M6x40 Socket Head Screw
4.5	Spherical Washer M6 - 2 pcs
4.6	M6 Custom Nut
4.7	M6X35 Socket Head Screw

TORQUE 8 Nm

* The saddle clamp kit is provided both with socket (N. 4.4) and hex (N. 4.3) head M6x40 front screws. The second one is recommended to ease the mounting of closed saddles.

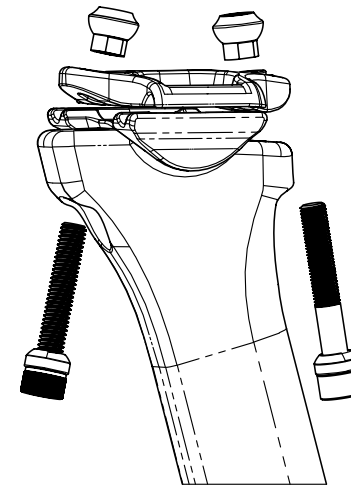

Note: seatpost 0-offset must be fixed with the 2 bolts from the bottom, featured with the dedicated spherical washers (N. 4.5)

Front axle installation

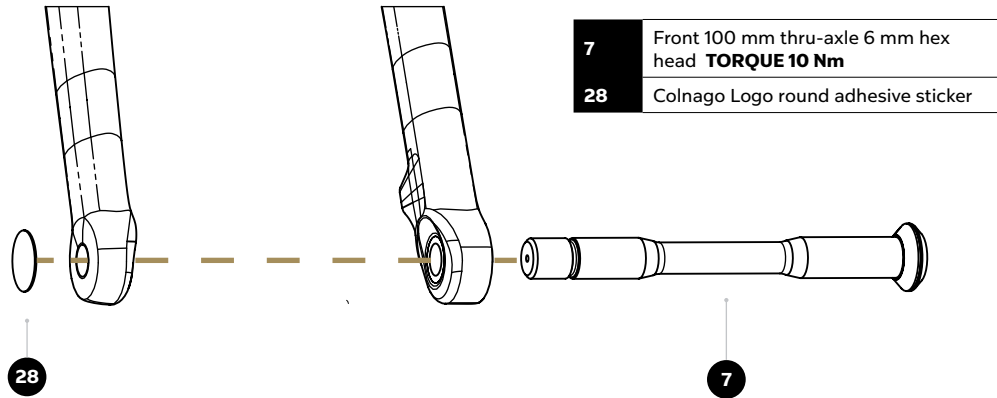

7	Front 100 mm thru-axle 6 mm hex head TORQUE 10 Nm
28	Colnago Logo round adhesive sticker

UDH - rear derailleur hanger installation

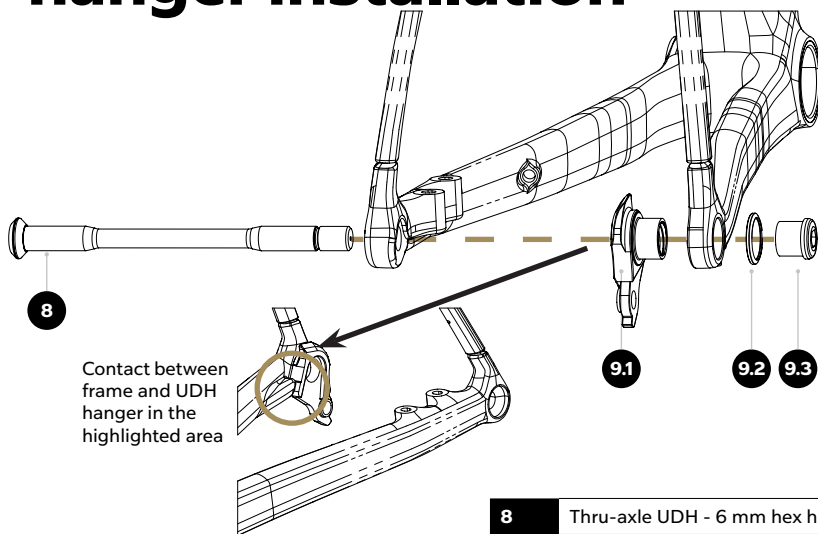

Contact between frame and UDH hanger in the highlighted area

8	Thru-axle UDH - 6 mm hex head TORQUE 10 Nm
9.1	UDH Hanger
9.2	UDH Hanger - Washer
9.3	UDH Hanger - Cap TORQUE 25 Nm

Front derailleur hanger installation

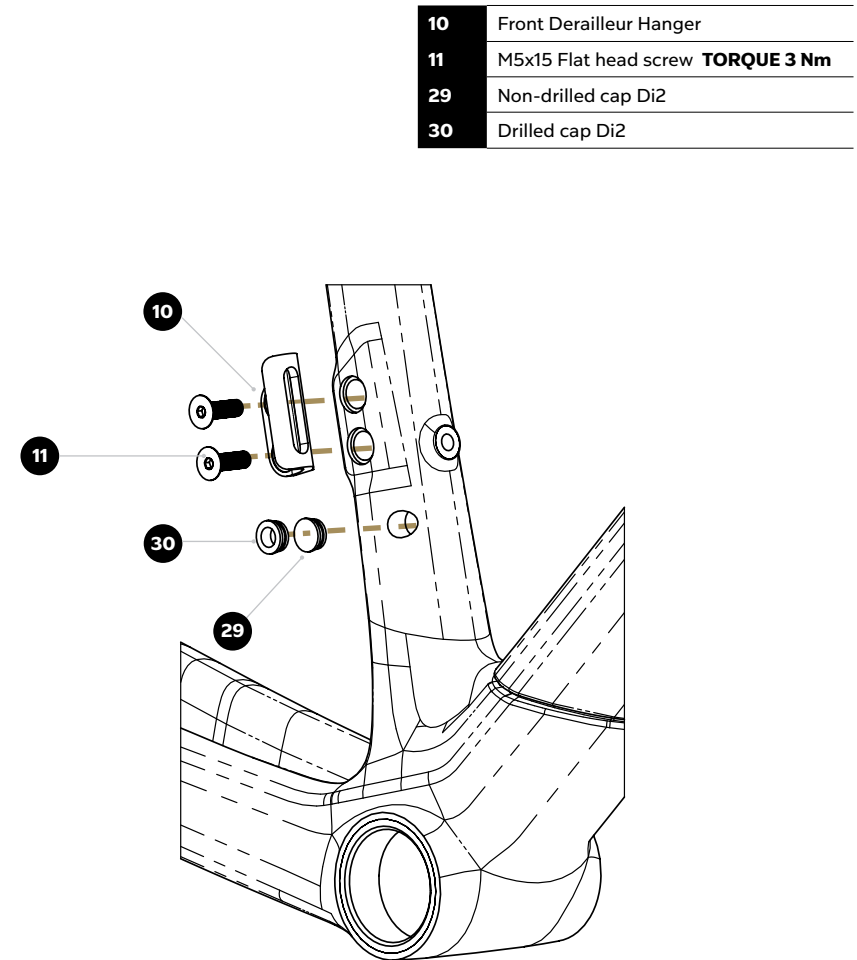

10	Front Derailleur Hanger
11	M5x15 Flat head screw TORQUE 3 Nm
29	Non-drilled cap Di2
30	Drilled cap Di2

Fork, headset and handlebar installation

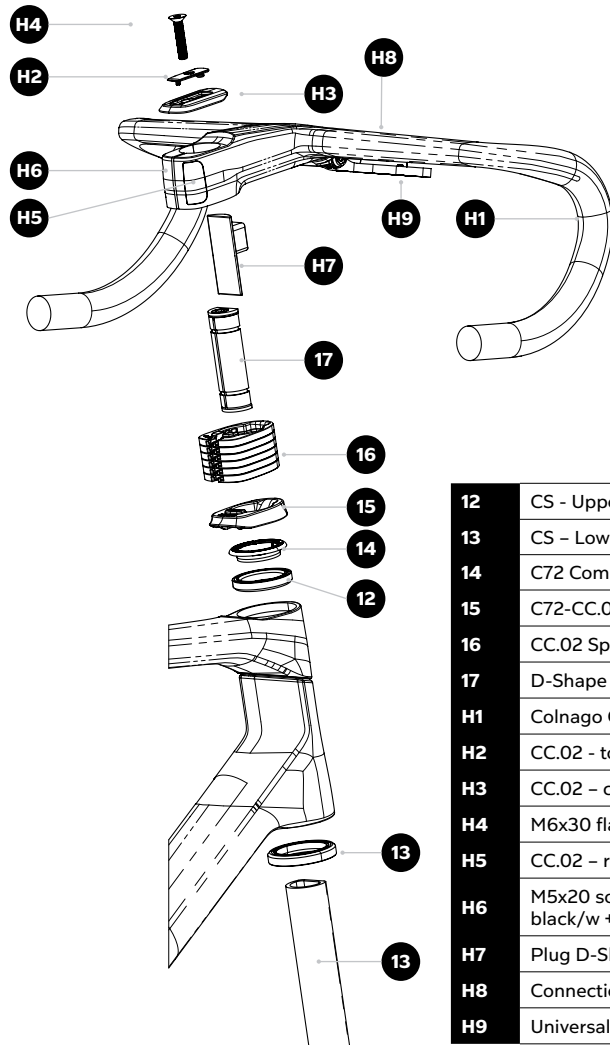

12	CS - Upper Bearing 31x40x7 SLT
13	CS - Lower Bearing 35x47x7 SLT
14	C72 Compression Ring
15	C72-CC.02 Dust Cover
16	CC.02 Spacer 5 mm open
17	D-Shape Expander TORQUE 7 Nm
H1	Colnago CC.02 integrated carbon cockpit
H2	CC.02 - top screw cover
H3	CC.02 - carbon forged top cap
H4	M6x30 flat head screw stainless steel/black
H5	CC.02 - rear alloy nut
H6	M5x20 socket head screw stainless steel/black/w + washers TORQUE 5 Nm
H7	Plug D-Shape - self-centered
H8	Connection mount CC.01/CC.02
H9	Universal support arm

Fork, headset and handlebar installation

Step 1

Step 1: apply the specified grease to the bearing seats and install the two bearings (N. 13 bottom and N. 12 top), the compression ring (N. 14), the C72 dust cover (N. 15), and the required number of spacers (N. 16) onto the fork steerer tube.

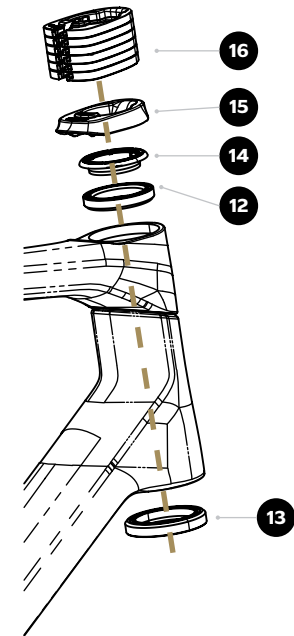

Step 2

Step 2: once the fork steerer tube has been cut to the proper length according to the desired number of spacers, and the brake hoses have been routed inside the frame and fork (see section "Brake Hose Routing"), insert the D-Shape Plug CC.02 (N. H7) into the handlebar stem from the bottom and push it toward the front of the stem. This will ensure that the brake hoses are properly guided from the head tube to the stem by the guide located at the front of the plug.

Apply the appropriate grease to the surface between the D-Shape plug and the steering tube to facilitate insertion and subsequent handlebar removal

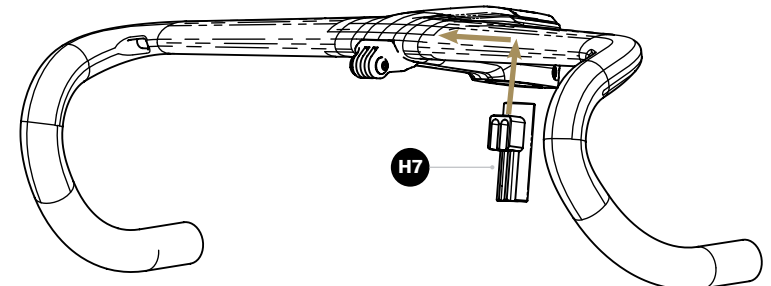

Fork, headset and handlebar installation

Step 3

Step 3: Secure the spacers (N. 16) using their rear clamp. Insert the handlebar onto the steerer tube, then install the D-Shape expander. Tighten the D-Shape expander to a torque of 7 Nm, ensuring that its top surface is flush with the top of the previously cut fork steerer tube.

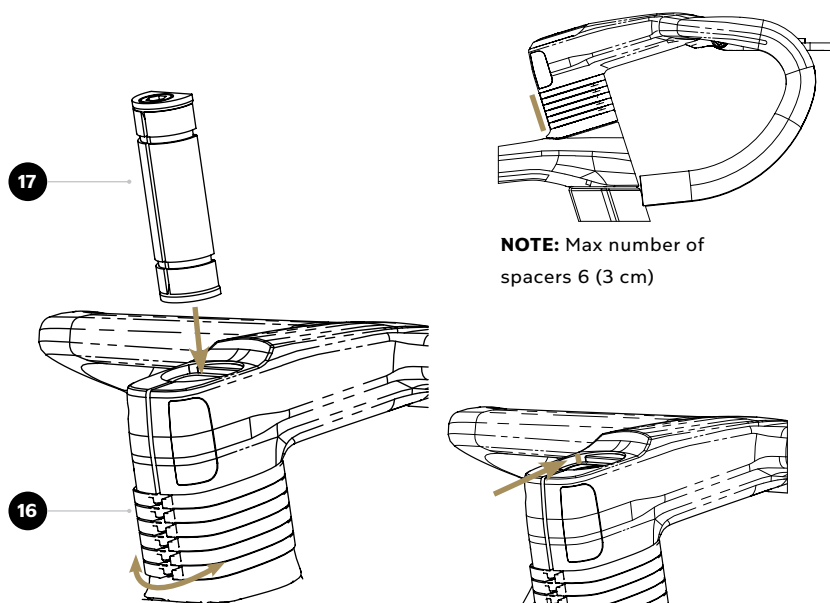

NOTE: Max number of spacers 6 (3 cm)

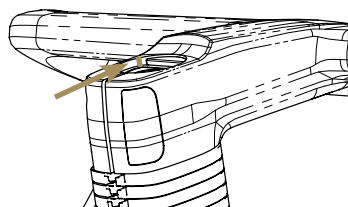

NOTE: Check that the fork steering tube is cut 2-3 mm below the cockpit stem top surface to allow a proper preload application.

Fork, headset and handlebar installation

Step 4

Step 4: Use the top cap (N. H3) and the M6x30 screw (N. H4) to apply the required preload to the headset. **Maximum torque: 4 Nm**

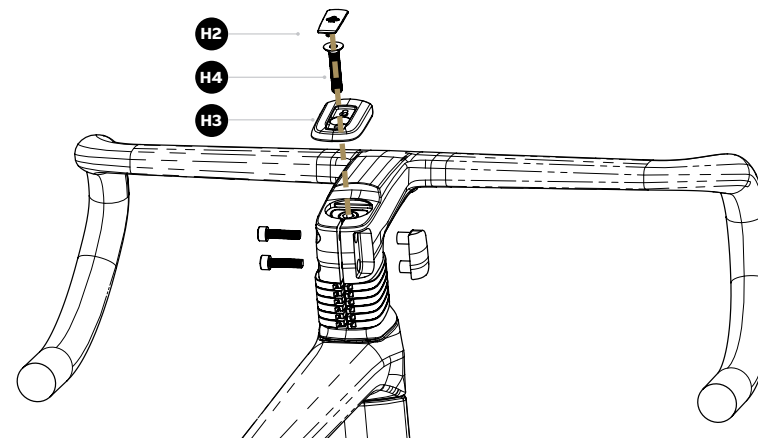

Step 5

Step 4: After applying the preload in Step 4, secure the integrated cockpit CC.02 using the lateral M5x20 screws (N. H6) and the custom alloy nuts (N. H5).

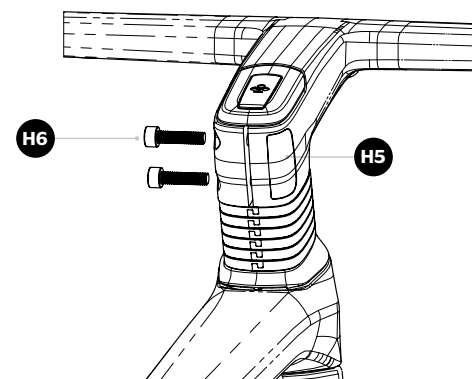

Fork, headset and handlebar installation

Step 6

Step 6: Install the CC.02 top cap cover (N. H2) to conceal the preload screw by pressing it into its seat in the top cap (N. H3).

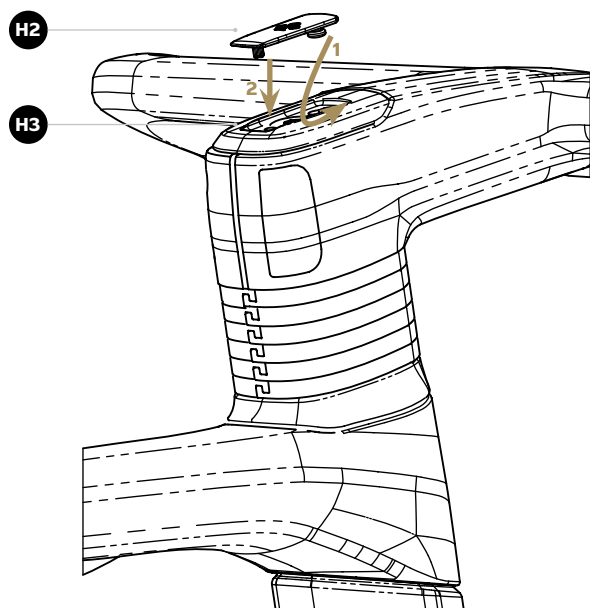

Fork, headset and handlebar installation

Step 7: Secure the CC.01/CC.02 connection mount (N. H8) to the CC.02 cockpit using the screw located at the front of the stem (maximum torque: 3 Nm). Then install the universal support arm (N. H9), placing the appropriate adapter in one of its two mounting positions according to the head unit model, in order to prevent any interference with the support arm.

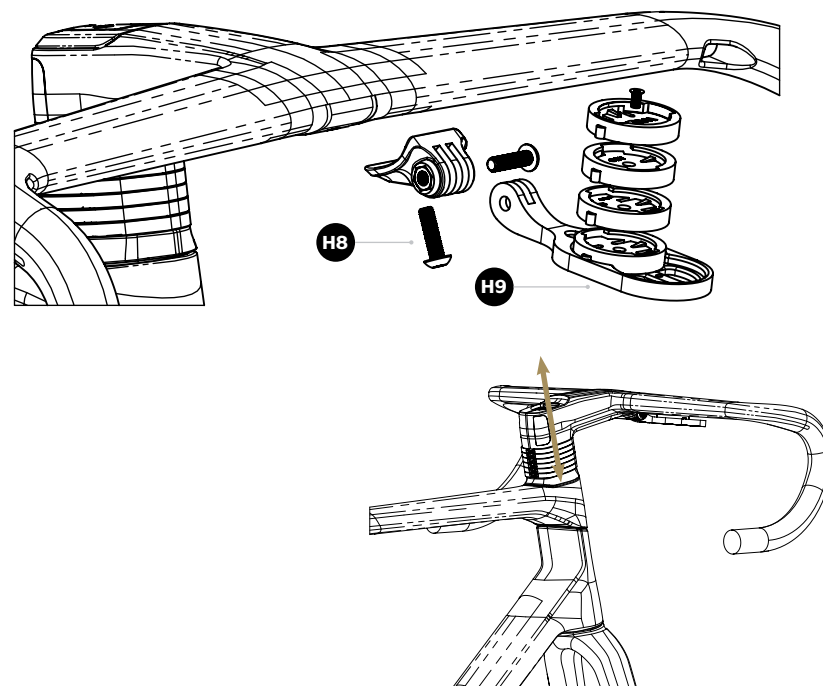

IMPORTANT NOTE: The D-Shape plug (N. H7) ensures perfect alignment between the fork and the handlebar. No further alignment adjustment is required. When installing or removing the cockpit, apply only longitudinal force. Do not attempt to rotate the cockpit relatively to the fork, as this may cause damage.

Di2 Battery support assembly

Step 1

Step 1: Install the Di2 battery rubber holder (N. 22) using the supplied zip tie, without fully tightening it.

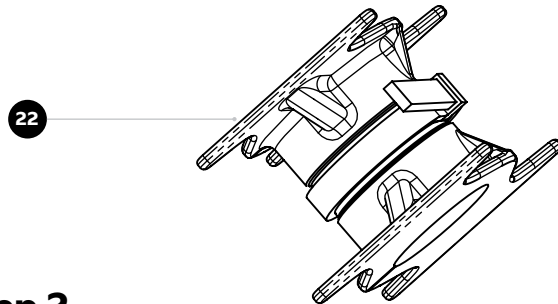

Step 2

Step 2: Insert the Di2 battery into the holder to approximately half of its length, then tighten the zip tie. After connecting the wires, push the battery assembly into the downtube toward the bottom bracket through the opening located in the middle of the downtube.

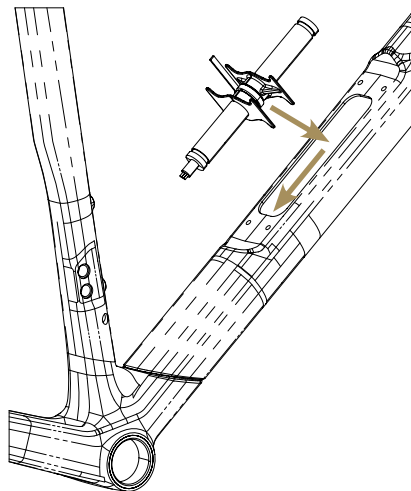

Integrated bottlecage support assembly

Step 1

Step 1: Install all the Colnago custom bottle cage clamp components (No. 19) onto the frame. Apply the provided protective stickers and secure the clamps using the supplied screws, as shown in the illustration.

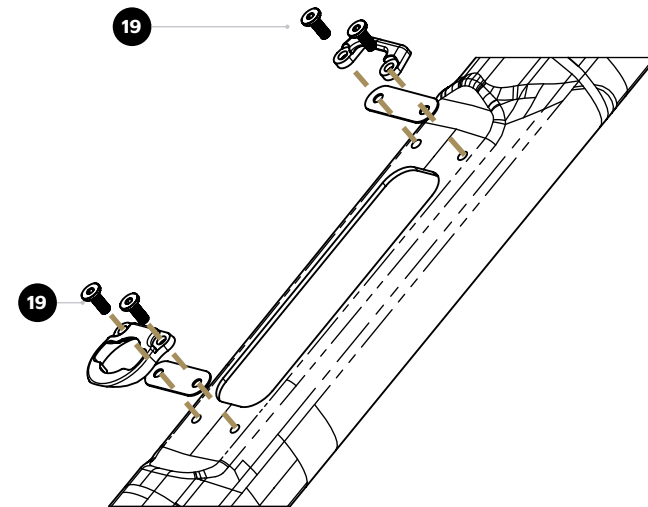

The Colnago C72 frame features a downtube storage box for tools and spare parts. To access the storage box, the supplied custom bottle cage must be installed as follows:

Integrated bottlecage support assembly

Step 2

Step 2: Keeping the lever / lower bottle holder perpendicular to the main body of the bottle cage (N.18), insert the front clamp into the corresponding front mount on the frame.

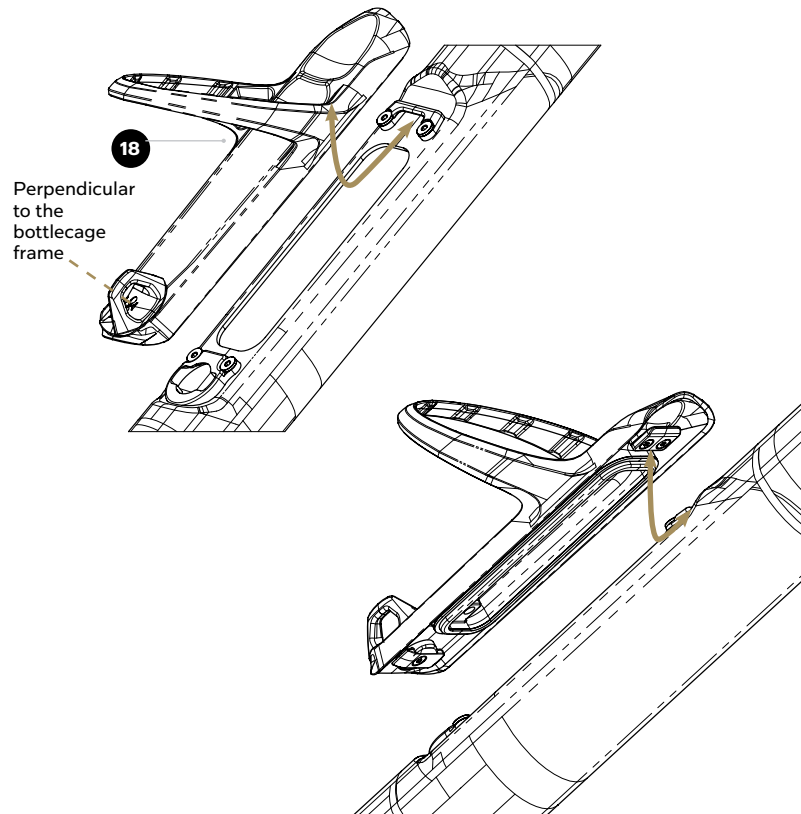

Integrated bottlecage support assembly

Step 3

Step 3: Apply force to the rear lever to engage the rear clamp. Then rotate the lever 90° until it is aligned with the frame to secure the bottle cage in place.

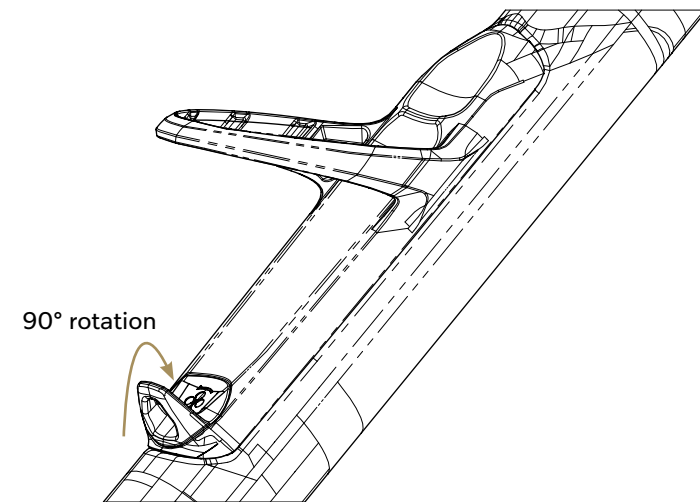

Brake hose routing

It is recommended that the rear hydraulic brake hose is installed before electric wires. These routing illustrations are intended as a supplement to the installation instructions only. For each specific brake system, please refer to the component manufacturer's service center or website for further information.

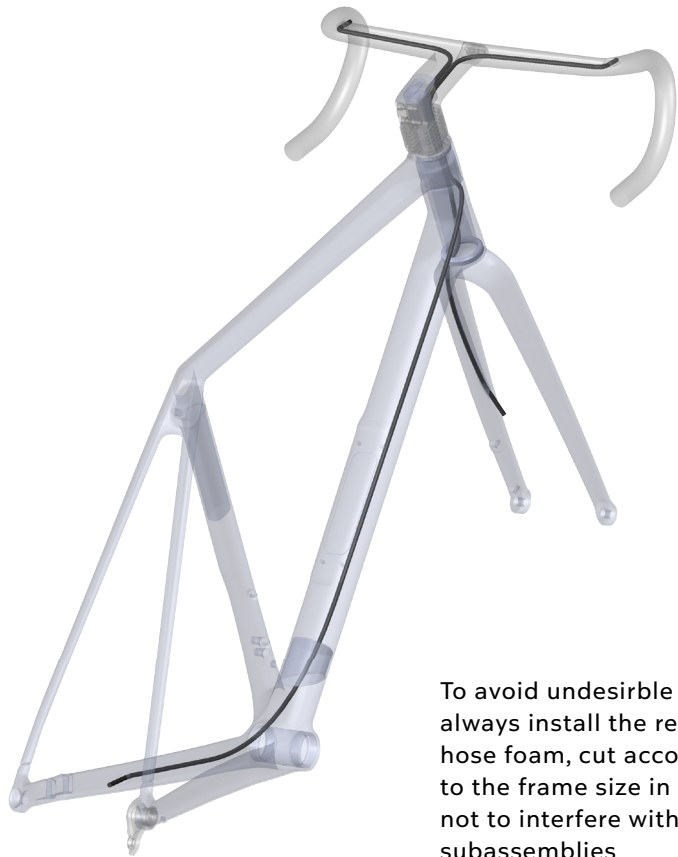

To avoid undesirable noises always install the rear brake hose foam, cut according to the frame size in order not to interfere with other subassemblies

Brake hose routing

To ease the procedure it is recommended to route the brake hoses before installing the headset and the Di2 battery. Once installed and routed the rear brake hose in the downtube, with a dedicated wiring tool with magnet in the end, pull the it through the preload bolt hole as shown in the pictures below.



To avoid undesirable noises always install the rear brake hose foam, cut according to the frame size in order not to interfere with other subassemblies

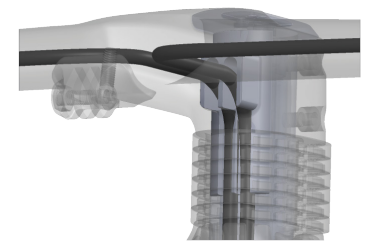

Electric Di2 wire routing

Colnago recommends installing electric cables and junction points after brake hose. The presented routing schematics are intended as a supplement to the groupset manufacturers' installation. For any more detailed information, please refer to the manufacturers' technical manual, website, or service center.



Tire clearance

Colnago frames and forks are designed to comply with ISO 4210-2 standard for tire clearance. For the road racing category, a minimum of 4 mm of clearance must remain between the tire and the frame or fork. The effective width and diameter of the tire can vary depending on the tire brand, the rim geometry and dimension and the tire inflation pressure. Colnago always recommends to check and respect the minimum clearance before choosing both front and rear tire.

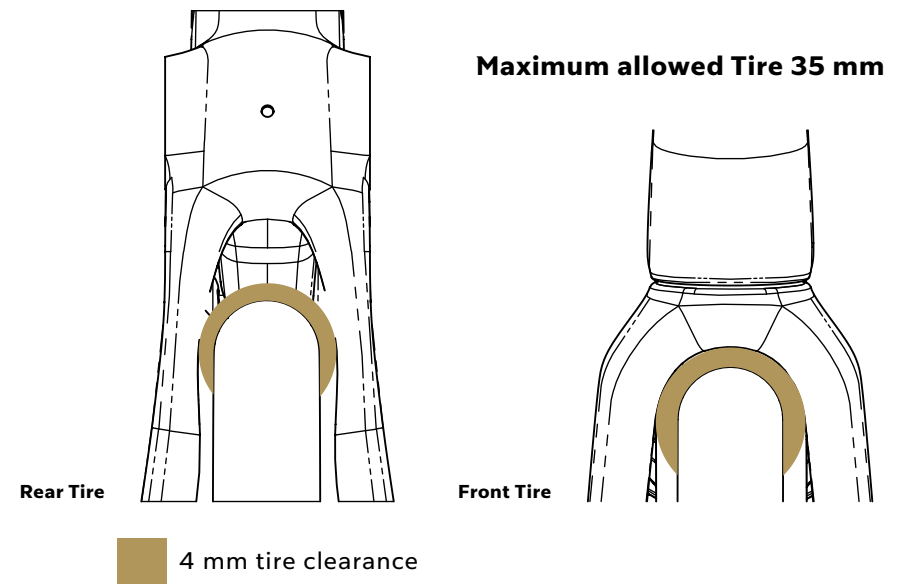

NOTE: Contact between the tire and the frame or fork may lead to a component or subassembly failure while riding, with potentially serious injury for the rider. Damage to the bicycle due to non-compliant tire clearance is not covered by the bicycle warranty.

Intended Use for Colnago C72

Road Racing Bicycle – High-performance/premium bike

Intended surface: Colnago C72 is designed for riding on a paved surface with both the tires always in contact with the ground.

Not Intended surfaces and uses: Colnago C72 is not conceived for off-road, cyclocross, touring with additional extra bags or racks, or mounting child seats or trailers.

The Colnago C72 is a made-in-Italy bike engineered to deliver the ultimate riding experience. Thanks to Colnago's traditional lug-and-bond construction, the use of premium carbon fiber, and the updated geometry, the C72 offers exceptional handling and stability in all riding conditions, while maintaining the stiffness and lightweight characteristics of a top-tier racing bike. The generous tire clearance further enhances comfort and confidence, even on rough surfaces. This makes the C72 capable of providing riders with the most enjoyable experience possible, from relaxed rides to race-like conditions.

WARNING:

Any abuse in the usage is hazardous and may lead to serious consequences.

Weight Limit

Colnago bicycles are tested to a maximum admissible mass* of 110kg.

COLNAGO C72

Max Admissible Mass

110kg - 242.5lbs

NOTE:

Each component has different weight limits, and if replaced can alter the maximum safe bike weight limit, since the most restrictive one is defining the limit of the whole vehicle. Consult your Colnago retailer about what components are suitable for your Colnago Y1Rs.

*Maximum admissible mass is the sum of the bicycle with all its components (groupset, cockpit, wheels, etc.), plus the rider and any luggage or accessory (head unit, filled bottles, storage mounts, etc.).

Torque and fasteners recommendation

To maintain correct tightening torques of all the threaded fasteners is crucial to your safety. Always tighten fasteners to the correct torque. Too high torques can stretch and deform fasteners. Too low torques can cause unwanted fastener movements leading to unfastening and fatigue failures.

Use only a correctly calibrated torque wrench with a proper scale to tighten critical fasteners on your bike. Carefully check to have the proper tools and follow their manufacturer's instructions on how to set and use the tool for accurate results before attempting any adjustments yourself. Before assembling and tightening any bolts, all threads must be greased with a quality, non-lithium type grease unless the bolt is pre-coated with thread locker. All bolts should have either grease or thread locker - but never both.

Colnago recommends the use of carbon assembly compound/friction paste for all areas of clamping to carbon fiber (seatpost to frame, stem to fork, and handlebar to stem joints). Such a paste reduces corrosion potential, and a decrease in required clamping force needed to support a given load. The paste should be evenly spread on the carbon surface under the clamped area.

WARNING:

In case of any doubt or disagreement or a conflict between the following list and any supplier literature on recommended torque values for original equipment components, please contact a Colnago retailer for review and clarification of the required torque before to keep on with the installation.

Torque setting tab*

Colnago is concerned about the resistance and quality of their frames. In order to guarantee the perfect conservation and durability of the frame over time, is important to maintain it correctly, by using a torque wrench.

REASONS WHY TO USE THE TORQUE WRENCH

1. Ensuring the frame and components are not over tightened which can cause damage or from components loosening from being under tightened. Cracks and damages caused by overtightening the bolts are not covered by Colnago Warranty.
2. Avoiding any harm to the cyclist whilst riding, due to the failure of incorrect installation.
3. Frameset and components benefit from a longer lifespan, even after multiple maintenance and service schedules during its lifetime.

DESCRIPTION	MAX TORQUE (approx.)	TOOL
Rear clamp screws CC.02	5 Nm	4 mm Allen key
Head Unit Support CC.02	3 Nm	4 mm Allen key
Colnago Bottom Bracket cups	30-35 Nm	BSA key
Colnago C72 Seatpost clamp bolt	7 Nm	4 mm Allen key
Colnago Saddle clamp bolt	8 Nm	5 mm Allen key
Bottle cage bolts (Seat tube)	2.5 Nm	4 mm Allen key
Custom bottle cage bolts (Down tube)	2.0 Nm	2 mm Allen key
Wheel thru-axle	10 Nm	5 mm Allen key (6 mm for UDH std)
Brake Caliper bolts	6-8 Nm	4 mm Allen key
UDH Hanger	25 Nm	8 mm Allen key
Front Derailleur hanger (on frame)	3 Nm	4 mm Allen key

* The presented table includes torque setting indication provided by Colnago. It is always recommended to check indication provided by each specific component' manufacturer.

Technical Information

COLNAGO Y1Rs	
Model Year	2026
Frame Size	420 - 455 - 485 - 510 - 530 - 550 - 570
Available Colors	
Brake Mount Type	Flat Mount disc rear - 140 mm rotor (160 mm with spacer) Post Mount front 160 mm
Chainstay Height (Flat Mount)	20 mm
Wheel Size	700c
BB Type	BSA - 68 mm
Upper Headset Bearing Dimensions	1-1/8; 41X30X7
Lower Headset Bearing Dimensions	1-1/4; 47x35x7;
Seatpost	Custom C72 Seatpost - Available with offset -15mm and 0 mm.
Seatpost Clamp	Custom C72 Seatpost pushing block
RD Hanger	Standard UDH
Front Axle Dimensions	Thru-axle 12mm - 100mm hub - 1,5 mm pitch
Rear Axle Dimensions	Thru-axle 12mm - 142 mm hub -UDH Thread - 1 mm pitch
Maximum Tire Width (Actual)*	35 mm with 4 mm clearance

*Tire measurements shall be taken at the widest point and at the maximum diameter when it is installed on the rim and inflated for at least 24 hours. 4 mm of distance is required between the tire and any frame or fork element.

Geometry Chart

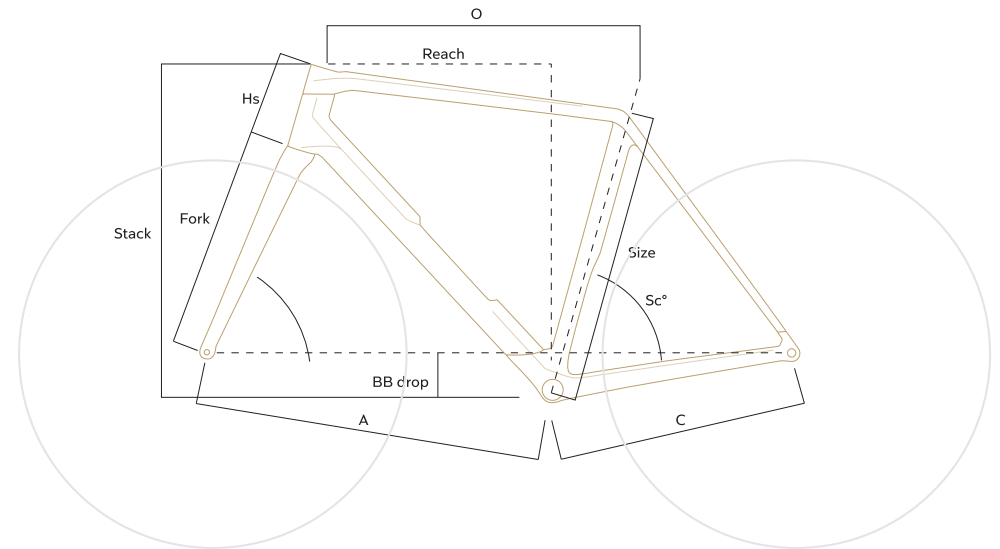

Size	Ss°	Sc°	Reach	Stack	Fork length	Rake	Trail (30-622 tyre)	HS	Wheelbase	C	Standover	A	BB drop	O
420	70.8	75.5	370	512	377	45	73.2	101	971	408	679	575	74	505
455	71.6	75.3	375	525	377	45	68.0	112	974	408	713	577	74	514
485	72.5	74.8	382	543	377	45	62.2	129.5	979	408	740	582	72	526
510	72.9	74.5	387	562	377	45	59.7	148	988	410	762	589	72	543
530	72.9	73.8	394	580	377	45	59.7	167	1001	410	781	602	72	563
550	72.9	73.5	402	599	377	45	59.7	187	1017	412	802	615	72	577
570	72.9	73.3	409	619	377	45	59.7	207	1030	412	820	628	72	591



colnago.com
info@colnago.com