

 **COLNAGO**

***C72***



**WHITE PAPER**

© Colnago 2026 All Rights Reserved



## Perfectly Composed

### WHAT'S SO SPECIAL ABOUT A C SERIES?

The C Series is the most authentic expression of Colnago.

It was born from the idea of the 'perfect bicycle', where aesthetics, engineering and performance come together with history and emotion. As evidenced by thousands of collectors and enthusiasts—from the C35 to the C68—the C Series stands as a unique object of design and cycling culture.

A distinctive feature in the landscape of major bicycle manufacturers, the C Series is still entirely handmade in Italy. It is built using a modular construction method, where the frame is created by joining individually engineered carbon tubes. This approach places Colnago alongside the world of true artisans, whose attention to detail, uniqueness, and craftsmanship are fully embodied in the Colnago C Series.



**The C72 is not a bike  
that excels in just one area.  
It is a bike where everything  
is perfectly composed.**

Hand-built in Italy, it reflects a different idea of performance: not the pursuit of a single extreme, **but the precise balance of all the elements that define the ride.** Structure, materials, geometry, and design are developed as one—nothing isolated, nothing exaggerated.

This is the essence of the C Series: a construction philosophy that allows every part to be shaped, refined, and assembled with **intent**, bringing all parameters into **harmony**.

The result is not just performance, but **performance—perfectly composed.**



## What's behind this idea of perfection?

1. Iconic heritage
2. Timeless design
3. Unique ride feeling
4. Top-tier performances
5. Production Excellence



## 1. **ICONIC HERITAGE**

A Colnago C Series represents a product of enduring value, widely recognized by the market. This is no coincidence: its reputation is built on an exceptionally high level of craftsmanship, and on a legacy where each new evolution of the C Series has introduced meaningful innovation.

## C SERIES IN THE YEARS

### C35 The Beginning of the Carbon Revolution



The C35 marks a true turning point. Developed in collaboration with Ferrari, it introduced an entirely new approach based on advanced material research and structural modeling.

A bike ahead of its time, it anticipated the future: carbon construction, aerodynamic thinking, and radical design. It stands as a bold declaration that carbon was destined to become the future of cycling.

### C40 The Icon



The C40 is arguably Colnago's most iconic bicycle. As the first carbon bike to win Paris-Roubaix, it proved that carbon could be not only lightweight, but also strong and race-winning.

With over a thousand victories in a single decade, it remains one of the most influential bikes ever created. It is the model that forever changed the perception of carbon in cycling.

## C50

### The First Evolution



With the C50, the goal shifted from revolution to refinement. Stiffness, precision and line purity were all enhanced, reinforcing the unique blend of performance and elegance that defines the Colnago signature.

It is a bike that refines an already strong identity, making it even more distinctive.

## C59

### Anticipating the Modern Era



The C59 marks the entry of the C Series into the contemporary era. With greater integration, internal cable routing, and a cleaner design language, it stands as a key innovation milestone.

Notably, it was the first road bike to be offered with disc brakes, anticipating a shift that would later become standard in modern cycling. Once again, Colnago demonstrated its ability to see ahead of the industry.

## C60

### Structure and Identity



The C60 further evolves the lugged construction concept, with larger, more structural joints that enhance stiffness and precision without compromising comfort.

Most notably, the bottom bracket area is now nearly twice the size of its predecessor. This evolution reflects the ongoing pursuit of reduced weight while maintaining—and improving—stiffness and resistance to flex.

## C64

### Pure Refinement



The C64 represents the full maturity of the concept: more elegant, with smoother lines and a marked improvement in comfort and ride quality.

It is one of the most balanced bikes in the C Series, capable of blending performance and riding pleasure with near-perfect harmony.

## C68

### A Modern Classic



The C68 brings the C Series fully into the present, with a higher level of integration and even more sophisticated construction. For the first time, some lugs are wrapped and made invisible, preserving the tube-and-lug philosophy while embracing modern standards.

With greater precision and versatility, it is also available in Allroad and Gravel versions. Additionally, it introduces, for the first time in cycling, a blockchain-protected digital passport system. It is the ultimate synthesis of tradition and innovation.



## PROUDLY HAND MADE IN ITALY

Behind every Colnago C Series frame lies a process where craftsmanship and innovation come together in perfect balance. From the creation of carbon tubes to their precise bonding, from hand-finishing to airbrush painting and final assembly, each step is carried out in Cambiago with meticulous care.

The process of manufacture can be summarized in a series of key stages:

- **Production of carbon tubes and lugs**
- **Bonding and assembly of tubes and joints in dedicated jigs**
- **Hand-finishing and surface refinement**
- **Hand-painted airbrush finishing**
- **Final assembly and quality control**

## MULTI-PIECE CONSTRUCTION: FINE-TUNED TO THE SMALLEST DETAIL



### All C Series are multi-piece modular frames

By designing each single piece and producing them in smaller casts, Colnago is able to customize the performances to the extreme level. Colnago uses different types of carbon fibers with different performances, in this way the ride experience gets finely tuned to match exactly our needs.

Making the bike modular also means the possibility to design more complex

shapes while maintaining the desired thinness and stiffness of the tubes. In doing so, Colnago achieves the distinctive aesthetic and maintains the overall low weight of this bike while delivering its best-in-class stiffness and responsiveness.

What is perfection? Perfection lies in a mix of factors: aesthetics, robustness, performances, but at the end of the day, it's all in what the rides feel during a ride. Modular frames are the key to having this happen.

## HOW IS THE C72 “COMPOSED”?



### Every C Series is different from the previous, but they keep the same DNA.

The frame is made of 7 tubes (the same number of tubes as the C68). The top tube is now a single piece that is joined directly with the seat tube. The rear triangle is now made of two

separate pieces: seat stays and chain stays are separate tubes.

What makes the C72 really different from its predecessor is the new approach of surface modeling, creating smooth and continuous surfaces, despite the multiple tube and parts construction.

## 2. TIMELESS DESIGN

The goal was to design a unique and elegant bicycle matching the C Series DNA with a clean design that clearly makes it stand apart. The design of this bike is that of a modern classic, by mixing iconic elements from the tradition of cycling while still looking fresh to the contemporary eye.





## PANEL GAP MATCHING

Each C Series model introduces a distinctive design element that sets it apart from its predecessors, while preserving a constant: the pride in showcasing the junctions where tubes and components come together.

The frame structure, deliberately exposed and unhidden, reveals the handcrafted soul and unique identity of the bicycle.

With the C72, a new visual language is introduced to express these junctions: panel gap matching. This stylistic approach is inspired by the automotive world, where icons such as the Ferrari F40 and Ferrari F50 pioneered this design principle.

The intent is to create continuity across surfaces, allowing lines to flow seamlessly throughout the entire bicycle. The eye perceives the frame as a composition of multiple elements through the subtle gaps between surfaces, much like adjacent body panels.

**The result is a lighter, more cohesive, and distinctly contemporary aesthetic.**

## FULL INTEGRATION

Bottle Cages  
Seatpost  
Storage Box

The clean and elegant appearance of the C72 is the result of a process focused on lean, complete integration. For example, the head tube and down tube are shaped to read as a

single, smooth volume, extending this integration to elements such as the bottle cages.

**The result is a frame defined by exceptional clarity and visual purity.**



### Bottle Cages

New custom carbon Colnago integrated bottle cage with storage box included. Patent pending structure for maximum integration and clamping stability.

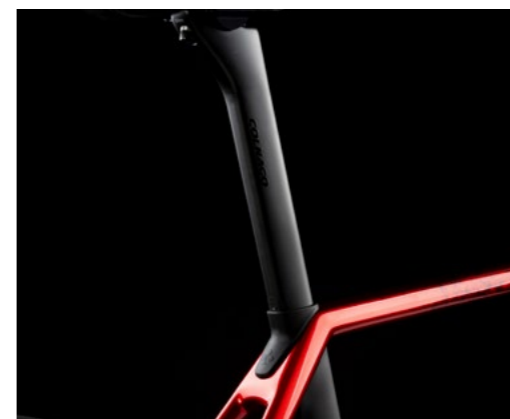

### Seatpost

New integrated seatpost with more aerodynamic shape and new pushing block system.



### Storage Box

Storage box including Colnago repair kit with keys, spare tubes and CO<sup>2</sup> adaptor.





### 3. **UNIQUE RIDE FEELING**

A 'perfect bicycle means one that adapts to your needs, a bike that reacts well when you want to push it to the extreme, and at the same time is stable and comfortable for when you want to adventure for long days on the saddle.



This bike is 'the best' for demanding riders who want to go fast and push hard with front end stability, precise handling, quickness in acceleration and direction changes, and the possibility to achieve modern racing positions.

C72 is 'the best' for riders who want to enjoy long riding experience where the bike is your adventure

companion, your trusted helper, and not a source of pain. It's possible to customize the riding position more toward 'endurance', with respect to the C68, along with improved vibration absorption and grip thanks to wider tire clearance—all without losing the high-performance riding experience of Colnago bikes.

## Revised geometry more toward 'endurance'

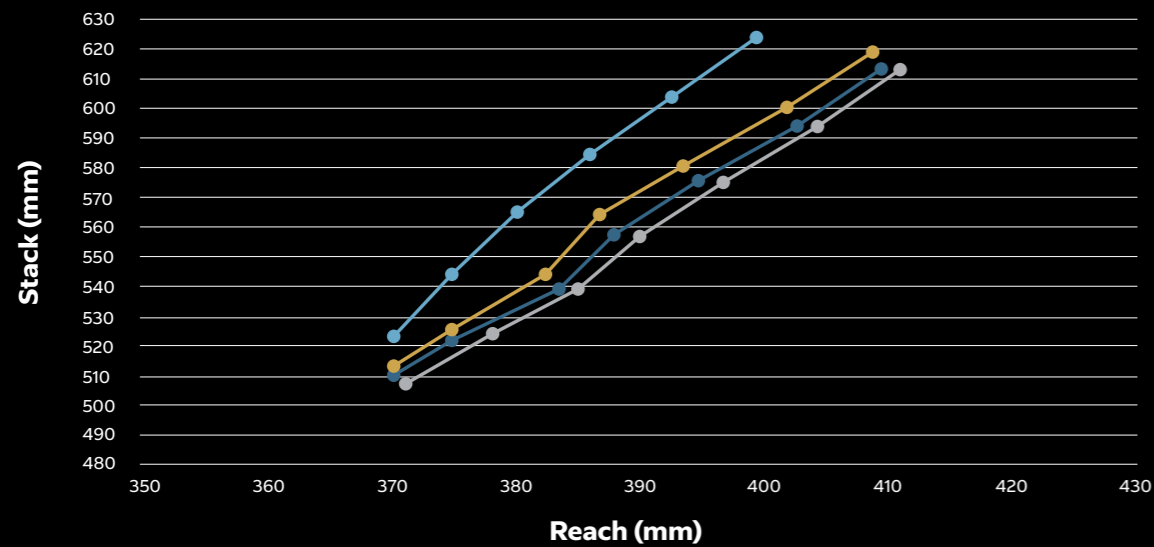

● V5 7 sizes   
 ● C72   
 ● C68   
 ● C68 Allroad

With respect to the C68, the stack/reach ratio is increased. It's still in racing range but more inclined toward comfort and endurance.

The C72 can be adjusted more toward endurance with respect to

its predecessor, but at the same time maintains an aggressive DNA. A steeper steering angle and longer reach reduce trail, maintaining the wheelbase, responsive steering, and quick handling typical of racing bicycles.

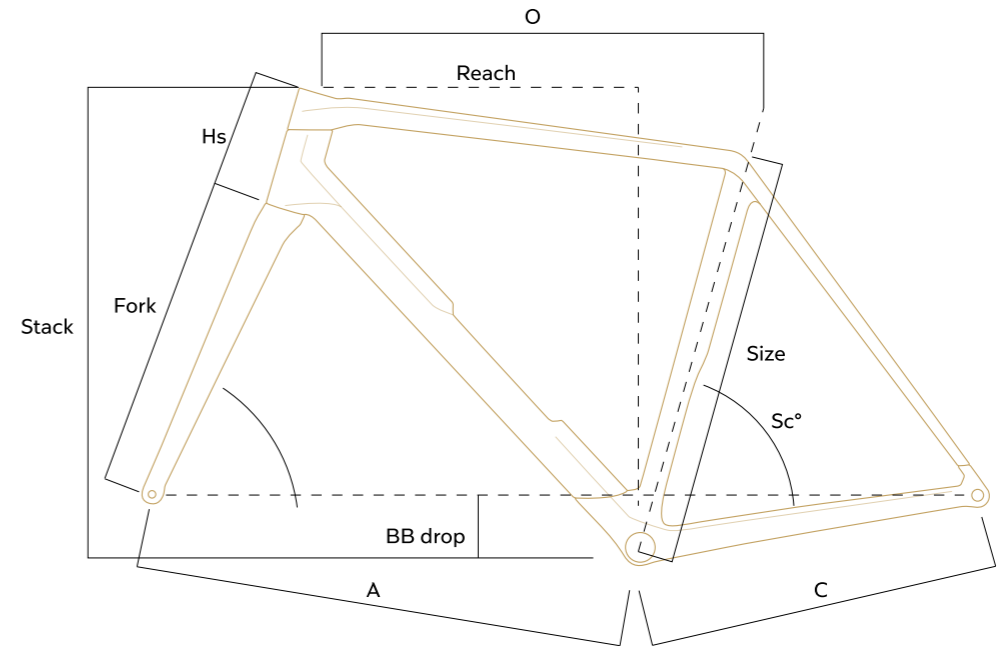

Geometry

Size	Ss°	Sc°	Reach	Stack	Fork	Rake	Trail (30-622 Tyre)	Hs	Wheelbase	C	Standover	A	BB drop	O
420	70,8	75,5	370	512	377	45	73,2	101	971	408	679	575	74	505
455	71,6	75,3	375	525	377	45	68,0	112	974	408	713	577	74	514
485	72,5	74,8	382	543	377	45	62,2	129,5	979	408	740	582	72	526
510	72,9	74,5	387	562	377	45	59,7	148	988	410	762	589	72	543
530	72,9	73,8	394	580	377	45	59,7	167	1001	410	781	602	72	563
550	72,9	73,5	402	599	377	45	59,7	187	1017	412	802	615	72	577
570	72,9	73,3	409	619	377	45	59,7	207	1030	412	820	628	72	591



### Tire clearance up to 35mm

This bike is designed for modern wide rims with 30 mm tires for performance. Tire clearance up to 35-622 provides for more comfort and vibration absorption.

### Improved compliance and shock absorption

Seatpost/Seatube and rear triangle shapes evolved to improve compliance and shock absorption, maintaining torsional stability. Carbon layup adjusted in combination with the tube shape to allow a superb vibration absorption, maintaining torsional stability in acceleration along with quick and precise handling and leaning support.





## 4. TOP-TIER PERFORMANCES

### Precise handling, for fast descents and sketchy roads

The steeper steering angle and longer fork rake lead to a wheelbase comparable with the C68, but with a more responsive steering action.

### A geometry made to accommodate even the modern efficient cycling positions

The C72 features a steeper seat angle compared to the C68, accommodating more front-forward positions. Combined with the frame's higher stack, this enables the rider to assume a position consistent with the latest findings in biomechanical efficiency.

### Quickness in acceleration and direction changes

The front triangle has been optimized for front-end stability and precise handling. The downtube and headtube section optimize the lateral and torsional stiffness, maintaining a low weight.

## Overall weight reduction from C68



With the C72, Colnago has reached a lower frame total weight despite increased clearance and the addition of the storage box—without compromising stiffness and handling.

Extreme lightness has never been the primary goal. However, this is a bike that compares with many top tier race bikes.

**Size 485**  
unpainted (no metal parts) = 895g

## CC.02 Cockpit

The C72 comes with an updated integrated cockpit, the Colnago CC.02.

The CC.02 has a new curve shape, that enables a more aggressive position and better brake control on a lower position. It is lighter than its predecessor—15 grams less than CC.01—and has a slightly different geometry, improving stability.

- Reduced reach for more stable handling while on the hoods
- Increased flare for better handling and riding stability

### Cockpit geometry

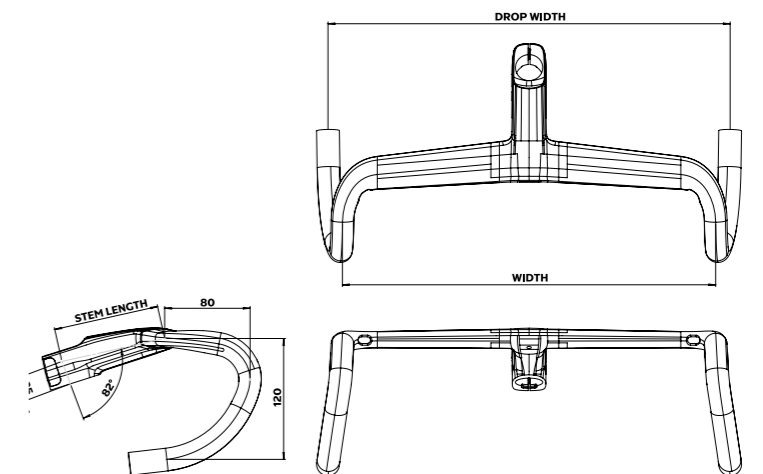

CC.02 size	Stem Length	Width	Drop width	Reach	Drop	Angle
90 - 390	90mm	390mm	420mm	80mm	120mm	82°
100 - 390	100mm	390mm	420mm	80mm	120mm	82°
100 - 390	110mm	390mm	420mm	80mm	120mm	82°
110 - 410	110mm	410mm	420mm	80mm	120mm	82°
120 - 410	120mm	410mm	420mm	80mm	120mm	82°
130 - 410	130mm	410mm	420mm	80mm	120mm	82°



5. **PRODUCTION  
EXCELLENCE**  
ONLY 3000 C72  
PER YEAR

**Time is the most precious resource of all—and it is at the heart of the C72's value.**

Its construction demands a sequence of meticulous, hand-executed processes, each requiring precision, care, and the expertise of skilled craftsmen. This dedication cannot be rushed.

It's why production is intentionally limited: no more than 3000 C72 frames can be created each year.



## Positioning

The C72 is positioned as the top of the range of Colnago bikes. It is the quintessential Colnago, in a category on its own.

It is designed to create the 'definitive' Colnago bike, a timeless masterpiece made to be enjoyed and to be kept.

In this respect it is similar to Steelnovo, that could be seen as the steel equivalent of C72, in terms of philosophy of product: a bike conceived to have maximum performances and be at the forefront of innovation, while still preserving heritage and iconic design

## Tech info

### GROUPSET Campagnolo Super Record WRL Disc

<b>WHEELSET</b>	Bora ULTRA WTO 45
<b>SIZES</b>	42-45.5-48.5-51-53-55-57
<b>COCKPIT</b>	CC.02
<b>GEARINGS</b>	52-36T - 11-36 13V
<b>SADDLE</b>	Road Liv. 5
<b>B. BRACKET</b>	BSA - 68mm
<b>BEARINGS</b>	1" 1/8 e 1" 1/4
<b>DISC BRAKE</b>	160 Front / 140 Rear
<b>BOTTLECAGE</b>	2x bottlecages + accessory bag
<b>BAR TAPE</b>	Colnago Grip Black
<b>TIRES</b>	Pirelli PZero Race 700x28

### GROUPSET Shimano Dura Ace R9270 Di2 Disc

<b>WHEELSET</b>	Fulcrum Sharq57
<b>SIZES</b>	42-45.5-48.5-51-53-55-57
<b>COCKPIT</b>	CC.02
<b>GEARINGS</b>	52-36T - 11-30 12V
<b>SADDLE</b>	Road Liv. 5
<b>B. BRACKET</b>	BSA - 68mm
<b>BEARINGS</b>	1" 1/8 e 1" 1/4
<b>DISC BRAKE</b>	160 Front / 140 Rear
<b>BOTTLECAGE</b>	2x bottlecages + accessory bag
<b>BAR TAPE</b>	Colnago Grip Black
<b>TIRES</b>	Pirelli PZero Race 700x28

### GROUPSET Shimano Dura Ace R9270 Di2 Disc

<b>WHEELSET</b>	Enve SES 4.5
<b>SIZES</b>	42-45.5-48.5-51-53-55-57
<b>COCKPIT</b>	CC.02
<b>GEARINGS</b>	52-36T - 11-30 12V
<b>SADDLE</b>	Road Liv. 5
<b>B. BRACKET</b>	BSA - 68mm
<b>BEARINGS</b>	1" 1/8 e 1" 1/4
<b>DISC BRAKE</b>	160 Front / 140 Rear
<b>BOTTLECAGE</b>	2x bottlecages + accessory bag
<b>BAR TAPE</b>	Colnago Grip Black
<b>TIRES</b>	Pirelli PZero Race TLR 700x28

### GROUPSET Sram RED AXS Disc

<b>WHEELSET</b>	Enve SES 4.5
<b>SIZES</b>	42-45.5-48.5-51-53-55-57
<b>COCKPIT</b>	CC.02
<b>GEARINGS</b>	48-35T - 10-30 13V
<b>SADDLE</b>	Road Liv. 5
<b>B. BRACKET</b>	BSA - 68mm
<b>BEARINGS</b>	1" 1/8 e 1" 1/4
<b>DISC BRAKE</b>	160 Front / 140 Rear
<b>BOTTLECAGE</b>	2x bottlecages + accessory bag
<b>BAR TAPE</b>	Colnago Grip Black
<b>TIRES</b>	Pirelli PZero Race TLR 700x28





**We are the Ace of Cycling.**

We pursue nothing but excellence.

We aim for the best at everything we do.

The audacious and victorious attitude  
of champions inspires us to create the most  
thriving and pioneer experiences.





[colnago.com](http://colnago.com)  
[info@colnago.com](mailto:info@colnago.com)