

LIVING

For heat recovery in multi-occupancy buildings with extract air ventilation.
And excellent return on investment.



Our concept: **LIVING**

Heat that you have already paid for can be used more efficiently. Instead of just ventilating out the hot extract air, the heat in the air can be applied to the radiator circuit by using highly efficient Systemair heat exchangers and heat pumps. Waste not, want not.

Energy efficient and safe

All components are optimized and carefully evaluated, from when the heat is recovered from the extract air until they are efficiently applied to the radiator circuit (max +60°C water).

Integrated fire function for better safety

The ability to evacuate smoke gases is so dependent on good fans and an optimal ventilation system. We also make it easier to take safety into account by integrating the controls to evacuate smoke.

Safety is of the essence for all property owners. Nobody wants to experience a situation where a fire leads to death or injury that could have been prevented if the right measures had been taken. Let's make sure you and your tenants can sleep well at night.

Easy installation

The centrally positioned extract air fan is replaced by the LIVING extract air unit with optimised function and operation for waterborne heating systems.

One quality supplier, one contact

Take advantage of the ventilation supplier with the widest range on the market. A supplier of both ventilation and heat pumps.



Systemair makes energy efficient ventilation easy. Not to mention profitable.

We are one of the world's leading ventilation companies, with operations in 45 countries. Our product program covers a wide range of energy efficient fans, ventilation units, products for air distribution, chilling machines, air curtains and heating products.

Save money and energy

You can save both money and energy by reviewing the ventilation system and its control. Ensure to ventilate more when the need is greatest, and less when the need is least.

Systemair offers you a control system with fine-tuned function and dependable components, which means that your indoor air retains high quality over time.



All experts agree that recovering heat from the used ventilation air in multi-occupancy buildings is splendid from an energy perspective. Let's look closer at our concept LIVING, a perfect solution for you and your property.

ROI at its best

How much can you save on a yearly basis with LIVING from Systemair?

This calculation is based on a multi-occupancy building with an exhaust air flow of 1 000 l/s. (An apartment needs approx 25 l/s. 1 000 l/s equals the need of a building with approx. 40 apartments.)

Other conditions:

- Heat demand (full power and/or part load) from October to May (approx. 65% of the year's hours).
- Heating system with return temperature of up to +55°C at the design outdoor temperature and an average consumption.
- Savings are based on these rates:
Electricity: 0.12 EUR/kWh. Heat: 0.08 EUR/kWh.

If you choose LIVING you save up to 175 EUR per apartment and year. Or in total, 40 apartments, 7 000 EUR every year.

LIVING from Systemair gives you better ventilation, energy-efficiency and reduced operating costs. Since all this increases the value of your property significantly, an investment in LIVING could be one of the best investments you could make.

On top of this you also get an environmental friendly and sustainable solution.

LIVING model	Property's energy consumption in kWh	Calculated saving (heat) with LIVING (air flow 1000 l/s) in kWh	New energy consumption (usage with heat pump) in kWh	Saving in EUR/year	Increased value of property (4% ROI) in EUR/year
HP20	360 000	140 000	266 667	5 600	140 000
HP25	360 000	140 000	255 000	7 000	175 000

LIVING HP

With integrated heat pump

The easy way – all inclusive

We make it easy for the installer. One supplier for both ventilation and heat pump means that the HP model gives the simplest installation.

This compact solution with an integrated high efficiency heat pump, gives you the highest efficiency with best energy recovery.

Consists of fan filter module plus heat pump module for heat transfer air/water.

High heat recovery

Extract air gives off the heat to the evaporator, which at a higher temperature via the condenser gives off the heat to the radiator circuit. This construction provides you with these benefits:

- Heat losses from the compressor and condenser are recovered
- Large heat transfer surfaces in heat exchanger gives optimal heat recovery

High efficiency

Optimal efficiency with speed controlled compressor adapts the need to give the highest ESSER (COP season) and increases savings.

- Low pressure drop
- Speed controlled compressor
- High COP: Up to 4.9 at nominal values and heating medium +40°C

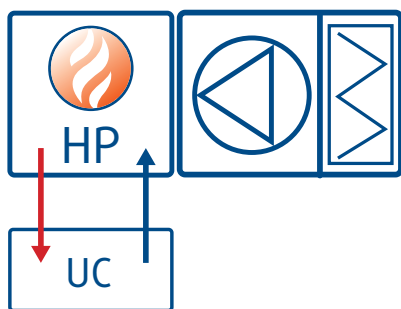

An extract air unit with heat recovery together with integrated heat pump.

High quality

The design is reliable because the evaporator is located in a low position, so that condensate does not leak down to the lower sections and sensitive apparatus. In addition, all key components are positioned in a tempered environment, which improves both operational safety and durability.

- Key components from leading suppliers with the best quality and performance
- Energy efficient fans with EC technology for optimal SFP
- Electronic expansion valves

Smart functions

A number of smart functions make it easier to select, install and use, including:

- Integrated air flow control
- Integrated fire control function
- Summer operation

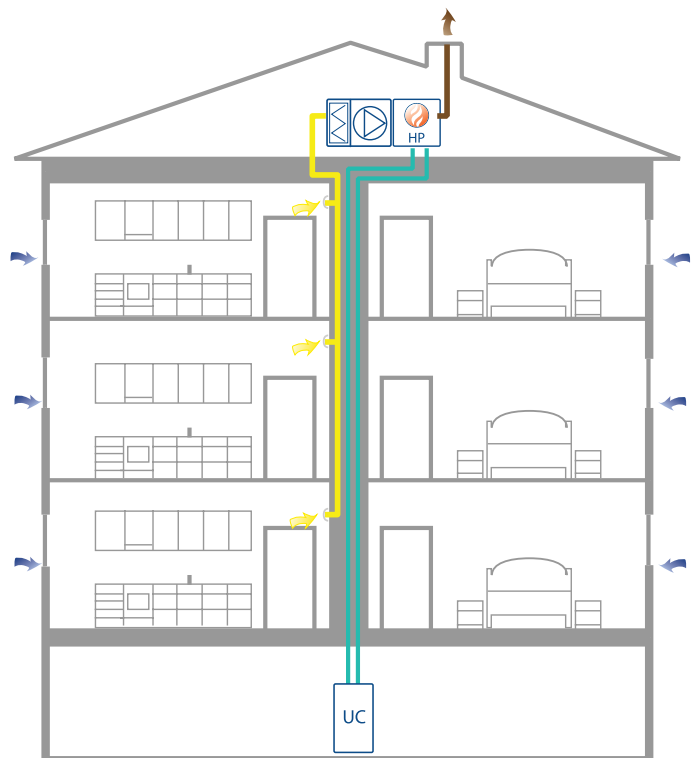

LIVING HR

For external heat pump

Reliable and efficient

LIVING HR is a reliable, simple and compact extract air unit with integrated heat recovery, optimised for best efficiency in combination with an external heat pump.

Simple installation

Control is also prepared for fire – everything to make the installation simple. A major advantage is that Systemair's range also includes external ground (water) sourced heat pumps which means that everything that is required comes from one supplier.

- One supplier – one responsibility
- Integrated fire control
- Integrated air flow control

Efficient heat absorption

You get optimal heat transfer thanks to heat exchangers dimensioned for the best performance with low pressure drop and optimum heat absorption.

- Large heat transfer surfaces
- Low pressure drop
- Heat absorption coils positioned low for longer service life

Compact solution

Limited space is no issue. LIVING HR is separate from the heat pump and has a low installation height, making it possible to place the heat pump in the smallest possible area.

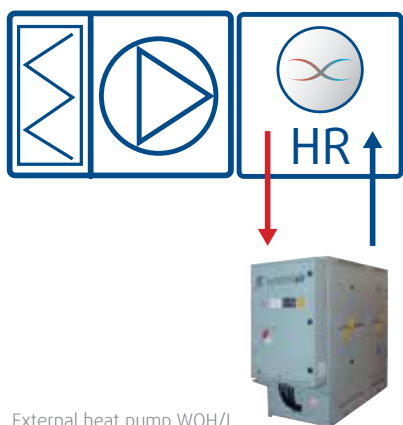

External heat pump WQH/L.

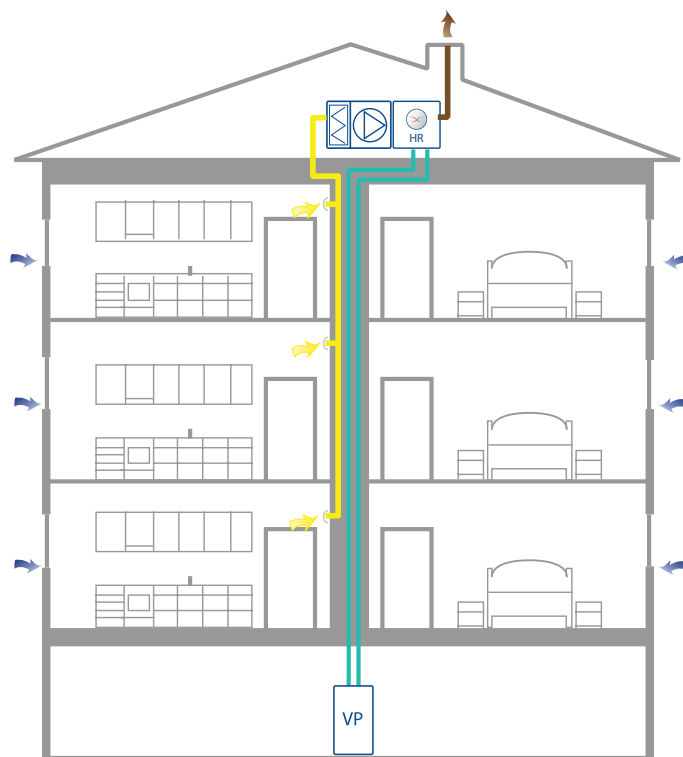

Control systems

Easy to deploy and operate

Function and operation is optimised for the water-borne heating system (HP), or to easily connect the brine circuit from the bore hole, which takes up the heat from the air and transports it to the external heat pump (HR). The controls are specially manufactured for Systemair's LIVING unit.

The unit is supplied preconfigured from the factory and the configuration, function and temperature can easily be set in the quick menus. The overview screen makes it easy to read off the status directly from the display, which, with the commissioning tool, makes the unit easy to start.

Safe operation

The operation is safe with functions that optimise and protect the compressor and refrigerant circuit.

The temperature control, damper control, the radiator circuit flow sensor and the defrosting function always being active creates full control of the whole system. HR has sensors and output signals that allow simple control of external pumps and/or valves to eliminate freezing of the heat recovery coil.

Summer operation

LIVING HP: To save the pressure drop in the summer when there is no heating requirement, an outdoor air temperature sensor sends a signal to the control unit that switches off the heat pump, closes the damper and the external smoke gas fan engages and operates as a normal extract air fan.

The flow is checked by the pressure/flow sensor and the smoke gas fan is regulated to maintain optimal flow.

LIVING HR continuously operates as a normal extract air unit even in the summer in order to always transfer heat from the extract air to the external heat pump. A function to exercise the smoke gas fan and damper is integrated in the controls.

Don't play with fire.

Combine with the market's best smoke gas fan

The fire control is integrated, and with an external smoke gas fan the smoke gases are evacuated.

Our DVG-EC smoke gas fan is the only smoke gas fan on the market that has an EC motor that saves up to 60% of the electrical power compared to normal, older, extract air fans. Perfect for summer operation in other words.

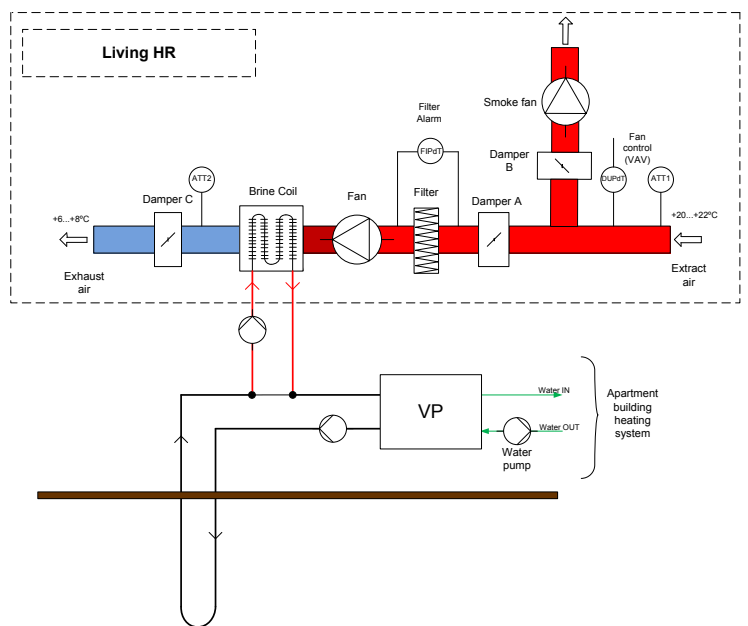
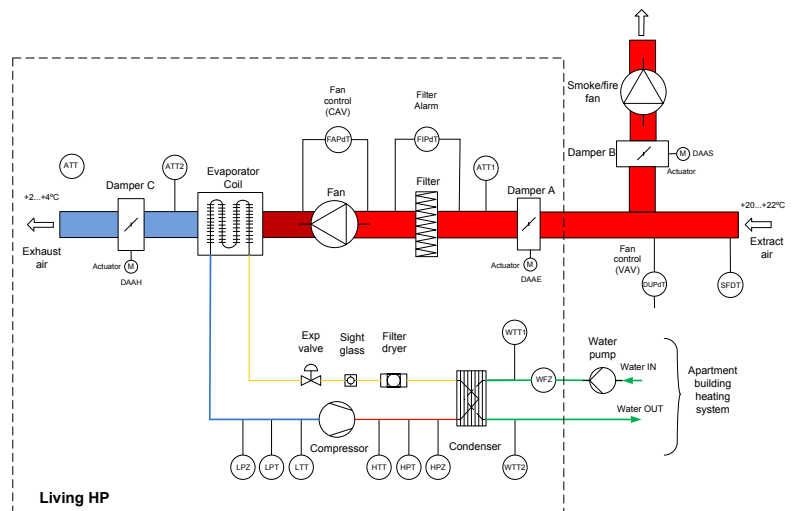

LIVING HP

Size	Number of apts *	Air flow l/s	Nom. l/s SFP <0.6	Outdoor /indoor	COP** nom	Heating kW
LIVING HP 15	10-22	250-555	444	Yes	4.5	16
LIVING HP 20	18-44	440-1000	722	Yes	4.4	30
LIVING HP 25	29-64	1000-1590	1278	Yes	4.5	42

* Standard apartment with 25 l/s

** At output heating medium +40°C and nom. air flow

***At max air flow and LWT + 40°C

	L	H	D	DH	DL	Weight (kg)
HP 15	1640	1120	1120	450	1000	347
HP 20	1640	1270	1270	500	1150	417
HP 25	1640	1420	1420	600	1300	495

Dimensions drawing

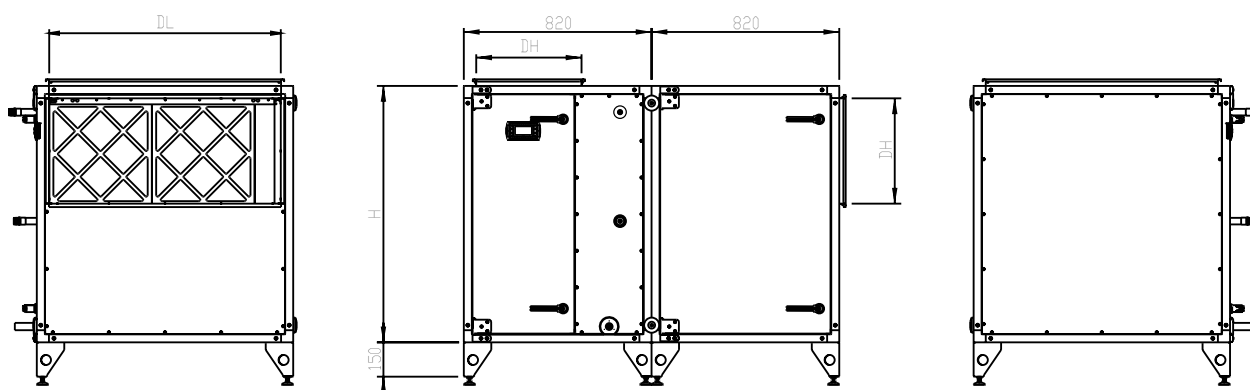

LIVING HR

Size	Number of apts *	Air flow l/s	Nom. l/s SFP <0.6	Outdoor /indoor	Heating kW **
LIVING HR 15	28	250-650	444	Yes	12
LIVING HR 20	24-50	600-1250	722	Yes	18
LIVING HR 25	40-70	1000-1750	1278	Yes	25

* Standard apartment with 25 l/s

**ΔT brine 5K 30% E.G.

***Max flow at 250 Pa external

	LS	L	H	D	DH	DL	Weight (kg)
HR 15	1120	2240	595	1120	450	1000	257
HR 20	1270	2540	670	1270	500	1150	329
HR 25	1270	2540	745	1420	600	1300	372

Dimensions drawing

