

# Geniox

Catalog





Copyright: Systemair NA 11. edition 2024.  
We accept no liability for printing errors or alterations of products.  
The dimensions and data used in this leaflet are a guideline only.  
Accurate calculations must be made in SystemairCAD.

# Contents

## Geniox

#HygienicByDesign . . . . .	5
Geniox features . . . . .	6
Geniox casing . . . . .	8
Systemair Access . . . . .	10
Quick selection of Geniox. . . . .	12
Configure Geniox with SystemairCAD. . . . .	13
Directives and certifications . . . . .	14
Standards . . . . .	15

## The Geniox Air Handling Unit

Indoor unit . . . . .	16
Outdoor unit. . . . .	17
Plug fan . . . . .	18
Rotary heat exchanger . . . . .	20
Plate heat exchanger . . . . .	22
Run-around coil heat exchangers. . . . .	24
Heating coil . . . . .	25
Cooling coil . . . . .	26
Change-over coil . . . . .	27
Air humidifier . . . . .	28
Filter rating comparison. . . . .	30
Panel filter . . . . .	31
Bag filter . . . . .	32
Virucidal Bag filter . . . . .	33
Metal filter . . . . .	34
Carbon filter. . . . .	35
Damper . . . . .	36
Sound attenuator . . . . .	38
Duct connection part . . . . .	39
Inspection section. . . . .	40
Empty section . . . . .	40
Supporting legs . . . . .	40
Assembly brackets . . . . .	40
Outdoor air section . . . . .	41
Standard base frame and base frame with high legs. . . . .	42
Base frame with forklift holes . . . . .	43
Weather hoods . . . . .	44



# Geniox is hygiene-friendly

Systemair believes that all air handling units (AHUs) should be **#HygienicByDesign**. We are of the firm opinion that hygienic measures should be a standard offering in all general ventilation units.

## #HygienicByDesign in a nutshell

Our #HygienicByDesign approach provides hygienic operating conditions, peace of mind and unmatched flexibility when it comes to meeting specific hygienic demands in projects. In short:

- All Geniox air handling units are hygiene friendly, designed and built for easy cleanability and with hygienic materials that ensure hygienic conditions in the AHU over time. All plastic materials comply with ISO846.
- The entire Geniox range can be configured into a Eurovent HAHU or VDI 6022-1 certified unit in a straight-forward, automated manner using the SystemairCAD selection software.
- Geniox AHUs also offer up to 2 stars in the Eurovent Hygienic AHU rating, which is comparable with VDI 6022-1 and similar national requirements.



## Optional Deltri+ virucidal air filters (see page 34)

Virucidal air filters with efficiency ePM1 90%, capable of neutralizing or destroying viruses – including SARS-CoV-2, as tested by the Luxembourg Institute of Science and Technology (LIST) and an independent laboratory. Proven efficiency with UL and Eurovent Certified Performance A+ energy class rating.

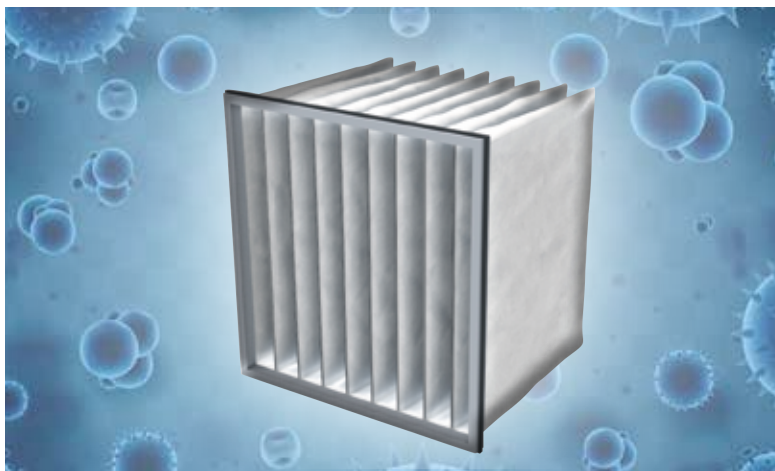

## CERTIFIED HVAC-HYGIENE

Conformity of the Systemair series Geniox and Geniox Go (selected as VDI 6022-1 certified in the SystemairCAD tool) with the hygiene requirements of the VDI 6022.



SWKI VA 104-01



## Green Ventilation

The Green Ventilation logo is a trustworthy environmental performance benchmark for our products. Only products that meet a set of hands-on, product category-related sustainability criteria are eligible to carry this mark.

# Geniox Features

Geniox is designed as a modular air handling unit. Each function is placed into an air handling unit casing consisting of one or more modules. The modular functions can be configured for many different applications to make up the heart of any ventilation system.

## Geniox is a modular air handling unit available in 16 sizes with airflows 440 CFM - 65,000 CFM (750-110,000 m<sup>3</sup>/h)

With rotary heat exchanger, run-around coil heat exchangers, cross flow heat exchanger, or counter flow heat exchanger.

- With water heating coil, electric heating coil, and/or cooling coil/DX coils.
- Can be supplied with humidifier/adiabatic cooling.
- For indoor or outdoor installation.
- Eurovent & UL certified.

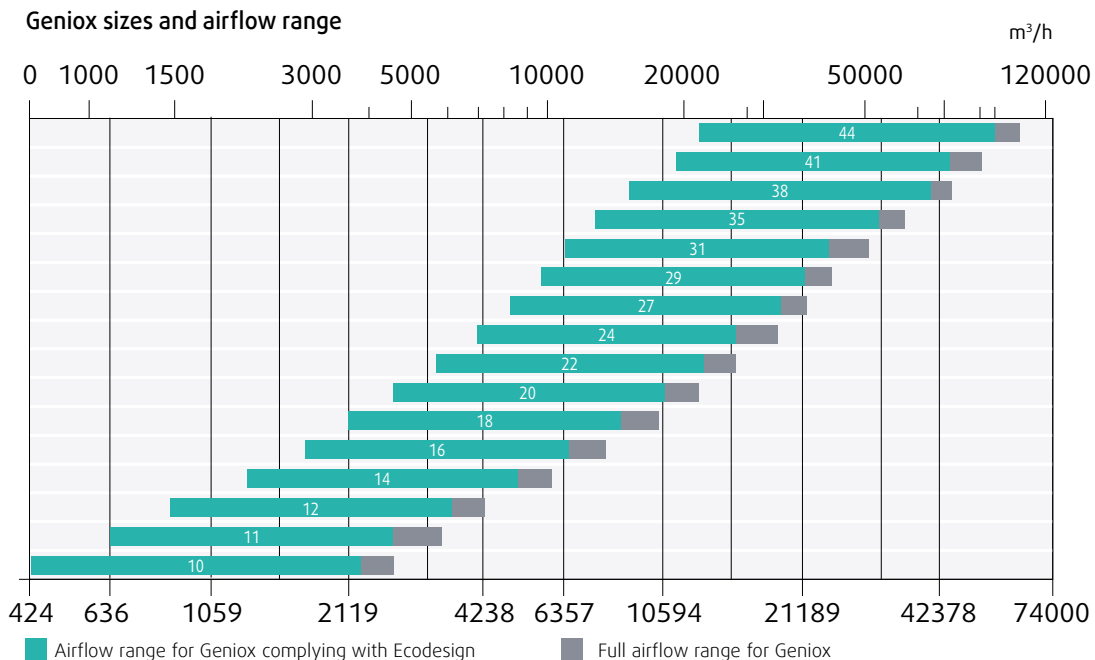



# Geniox Casing

Mechanical performances are the results of official model box test (EN 1886).

## Thermal insulation

Class T2. Sound and thermal insulating mineral wool, which is completely encapsulated between two steel sheets.

Thickness: 2.4" (60 mm). Density: 3.7 lb/ft<sup>3</sup> (60 kg/m<sup>3</sup>).

## Deflection

Class D1.

## Air leakage

Class L1 (M).

## Thermal bridging factor

Class TB2.

## Air handling unit casing

The casing protects the inside functions and is very effective for thermal and sound insulation.

## Operating pressure

Difference between external and internal pressure: 0 - 8 in.wg. (0 - 2000 Pa.)

## General temperatures

General temperatures for air in the air handling unit:

Standard design: -40/+104 °F (-40/+40 °C).

Special design: -40/+140 °F. (-40/+60 °C).

## Filter by-pass leakage

Class F9 according to EN 1886 (MERV 16 equivalent).

## Frame profiles

Powder-painted galvanized profiles inside, .04"/.06" (1,0/1,5 mm).

## Free area in front and above unit

When positioning the unit, we recommend that an area in front of the inspection side with the same width as the unit is kept free for service and inspection. At least an area in front of the unit which is equal to the maximum door width used in your unit.

For safe access to the cabinet with electrical components, if placed on top of the unit, the free area from the upper edge of the cabinet to the ceiling must be at least 27.6" (700 mm).

## Service and maintenance

All doors provide easy access for cleaning and service.

## Transportation

Casing design and standard packaging allows for easy transportation.



## Panels

The panels of Geniox are built using a sandwich construction with double sheets and 2.4" (60 mm) mineral wool for sound and heat insulation. The mineral wool is completely encapsulated, since the panels are closed on all sides. The panels with ZM310 surface are not only highly corrosion-resistant, class C5 according to EN ISO 12944-2:2000, but present an attractive, uniform appearance that can last for many years. The frame profiles are always pre-painted in RAL 7024.



## Handles and hinges

Practical handles and hinges make it possible to disassemble all doors and provide a space saving solution that is easy to service. All doors will have one handle with a lock. Doors with 2 handles: Lock placed in top handle. Doors with 3 handles: Lock placed in middle handle. Doors with 4 handles: Lock placed in one of the middle handles. Stacked air handling unit: The lock will be placed in the bottom handle of the top doors.



## Frame profiles and corners

Geniox is constructed using a framing profile, .04"/.06" (1,0/1,5 mm). The frame profiles are made of Z225 galvanized profiles inside and externally pre-painted. The result is a strong and robust construction able to resist twisting and lateral movement, making the unit extremely stable and strong. The corners are made of fiber reinforced plastic (PA6) which ensures strength and minimal thermal bridging.



## Inspection doors

Geniox has large inspection doors, making service access easy. The doors are mounted using solid hinges with easily removable pins. This means that the doors can be easily removed, if there is no room for normal opening of the doors. The doors are sealed using rubber profiles and have heavy-duty handles with minimum 1 lock on each door. They can only be locked and unlocked using a key.



**Outdoor unit**

Geniox is available as a roof top unit, designed for outdoor installation. In this version the unit is assembled on a base frame. The roof unit can be delivered with two different types of roofs:  
**Steel profile roof**, Aluzinc protected corrugated steel sheets and profiles for fastening and finishing the roof.  
**Bitumen membrane roof**, very easy to handle and has a good weather protection.



**Assembly brackets**

A Geniox air handling unit consisting of several sections can be quickly and efficiently assembled by using the assembly brackets on the outside.



**Inspection windows**

The windows have been designed exclusively for Systemair and provide a large area for easy inspection.

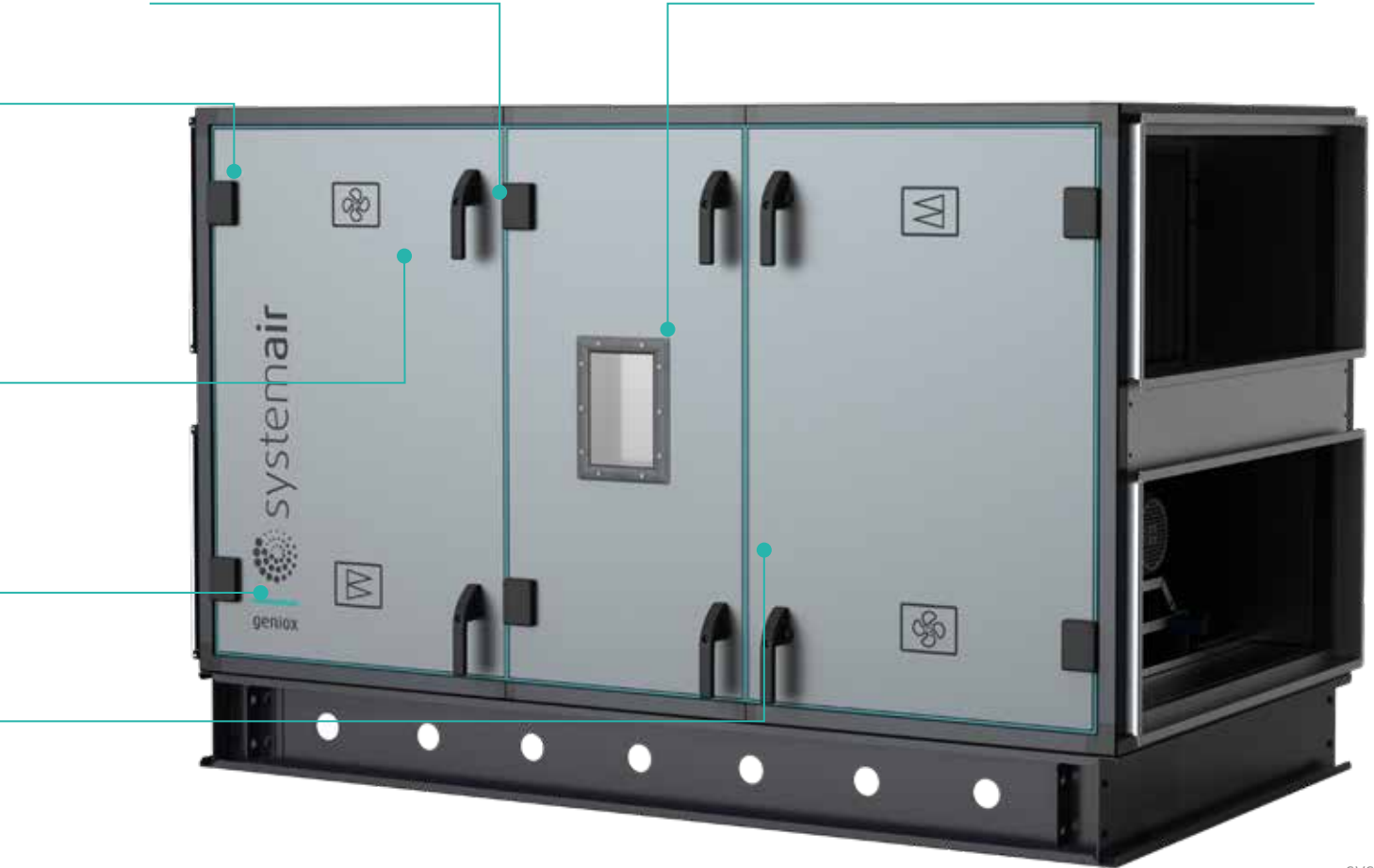

# Systemair Access NaviPad

Systemair Access is the complete control system for Geniox. Access has been developed by Systemair, designed for Geniox air handling units.

Systemair Access with wireless communication, a complete control system for air handling units, making advanced technology easily accessible.

It allows operators to optimize ventilation performance, helping them to create the perfect indoor climate. By operating the air handling unit at maximum efficiency you reduce energy consumption and operating costs.

## You are in full control

Choose your preferred device, smartphone, tablet or the handheld control panel, NaviPad.

Intuitive, easy-to-navigate menus help you achieve your chosen indoor climate.

Plug-and-play concept reduces installation, set-up and commissioning time.

Modbus communication to all internal components simplifies wiring, including inside the unit.

Cloud service for full monitoring and accessibility, even outside the building.

Wireless communication AHU(s) can be connected, configured and controlled via the Access Connect app on your smartphone or tablet.

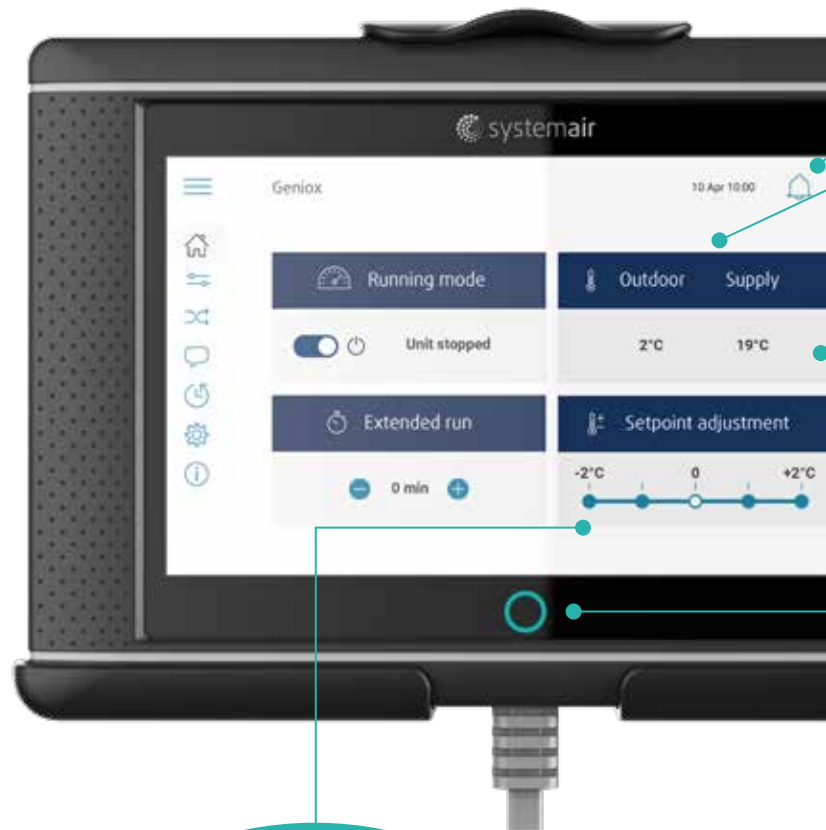

## GENIOX with ACCESS

NaviPad comes as standard with Systemair's Geniox air handling units.

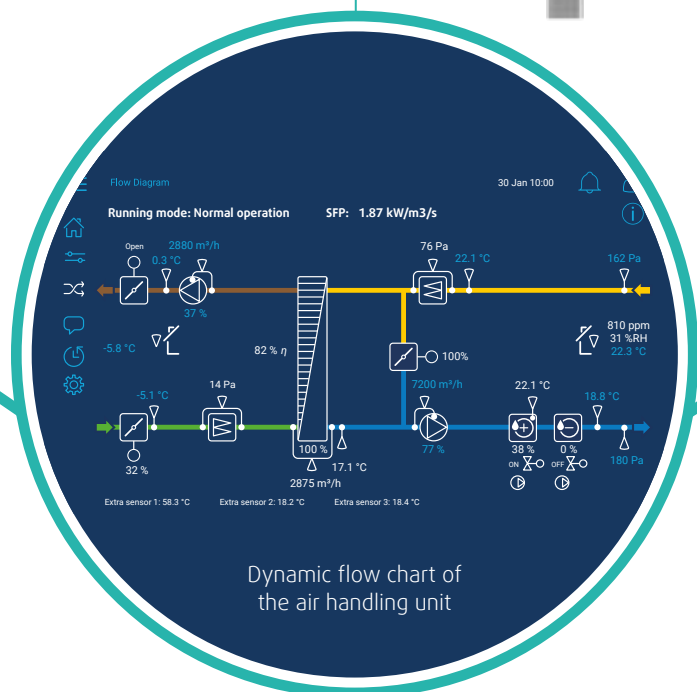

Dynamic flow chart of the air handling unit

### Always available

NaviPad puts you in control of your air handling unit – at all times. Should an error occur, you will immediately be notified by an alarm. Press the alarm icon to see the list of active alarms including the alarms history.



### Energy insight at a glance

With the Energy Insight function, it is easier than ever to monitor energy usage for fans (SFP value) and water heater as well as recovered energy for exchanger.

### It is easy to use

We were inspired by modern smartphones when developing NaviPad's user interface. Just click on an icon on your touchscreen to activate a function, change a setting or adjust a value. You will quickly learn how to control your unit as you go, thanks to NaviPad's intuitive graphical user interface.

### Live data

It is easy to monitor and adjust your air handling unit's performance. Relevant operating data and flow charts are easily available in real time and can be changed with a few clicks. You can view the status and adjust the settings of your air handling unit.

### Robust design

NaviPad is developed specifically for industrial use – simple to use, yet robust and durable in design. Drop tested and IP54 classified, your NaviPad will fit in most heavy-duty installations. A frame made of high-friction rubber will keep it firmly in your grip as you manage your air handling unit.

### See all units at once

Press the Home button to view the system overview dashboard. A LED-light will indicate current status. This provides access to a system overview dashboard for all connected air handling units, giving the operator control of several units from one NaviPad.



### Detachable

NaviPad\* is a robust control panel, designed specifically for industrial usage. It can be mounted on the air handling unit or on the wall, easy to detach for handheld use.

\*The NaviPad is connected via 3 m flat cable



# Quick selection of Geniox

Rotary heat exchanger		Unit size (in inches)															
		10	11	12	14	16	18	20	22	24	27	29	31	35	38	41	44
Unit	Width	42.6	46.5	50.5	58.3	66.2	74.1	82.0	89.8	97.7	109.5	117.4	125.5	137.1	137.1	160.7	160.7
	Height*	42.6	46.5	50.5	58.3	66.2	74.1	82.0	89.8	97.7	108.8	116.7	124.6	157.5	181.1	181.1	204.7
	Length	89.8	89.8	89.8	89.8	89.8	89.8	93.8	100.2	108.1	116.0	123.9	123.9	182.9	182.9	182.9	182.9

The above dimensions are a guideline only. Accurate values and combinations are calculated in SystemairCAD.

\* Height excl. legs/base frame.

(Legs/feet = 4.6" - baseframe 4.6" or 8.6")

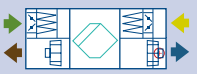
Plate heat exchanger Counter flow heat exchanger		Unit size (in inches)						
		10	11	12	14	16	18	20
Unit	Width	42.6	46.5	50.5	58.3	66.2	74.1	82.0
	Height*	42.6	46.5	50.5	58.3	66.2	74.1	82.0
	Length	125.3	133.1	133.1	137.1	148.9	148.9	156.8

The above dimensions are a guideline only. Accurate values and combinations are calculated in SystemairCAD.

\* Height excl. legs/base frame.

(Legs/feet = 4.6" - baseframe 4.6" or 8.6")

## Design an air handling unit

Geniox contains countless combination options. To ease the process of designing a unit the most popular combinations are illustrated here.

### Key to symbols

Exhaust air  Return air   
 Outdoor air  Supply air 

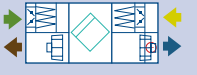
Plate heat exchanger Cross flow heat exchanger		Unit size (in inches)												
		10	11	12	14	16	18	20	22	24	27	29	31	35
Unit	Width	42.6	46.5	50.5	58.3	66.2	74.1	82.0	89.8	97.7	110.0	117.4	125.3	137.1
	Height*	42.6	46.5	50.5	58.3	66.2	74.1	82.0	89.8	97.7	108.8	116.7	124.6	148.9
	Length	117.4	121.4	125.3	133.1	141.0	148.9	148.9	175.0	186.9	194.7	214.4	214.4	269.5

The above dimensions are a guideline only. Accurate values and combinations are calculated in SystemairCAD.

\* Height excl. legs/base frame.

(Legs/feet = 4.6" - baseframe 4.6" or 8.6")

# Configure Geniox with SystemairCAD

It is easy to configure Geniox using SystemairCAD, a design tool which ensures that every air handling unit is customized for the actual conditions of each building.

When you configure your air handling unit, SystemairCAD does a number of calculations for you. Once you are finished, you can save all technical documentation as a pdf file on your computer.

The documentation contains e.g. technical data, drawings, calculation results, charts and a complete descriptive text that you can use in your specification document.

The drawing, which is made to scale, can be exported to other CAD or BIM programs as DXF or DMR files. Project files can be opened directly in AutoCAD or in Revit using the Systemair plug-in program MagiCAD.

You can also make LCC calculations, print to 3D-dxf files or print "live" air handling units to MagiCad or Revit.

SystemairCAD can be downloaded from Systemair's website.

## You design yourself

You can design your Geniox air handling unit yourself using SystemairCAD. The program calculates and generates the necessary documentation.

## Everything is double-checked

SystemairCAD notifies you of any irregularities in your design, and our experienced staff checks that everything is in order before your unique air handling unit is produced.

## Straight to manufacturing

Your drawings are ready to go straight into manufacturing at one of Systemair's plants, reducing administration and delivery times.



# Directives and certifications

## Eurovent certification

Geniox air handling units are Eurovent certified. This ensures the conformity between the calculated performance in SystemairCAD design program, and the measured performance at independent test laboratories.

## Eurovent energy classification

Geniox air handling units are energy classified according to Eurovent's guidelines for air handling units.

The energy class expresses the unit's total energy consumption.

The energy class is calculated by the design program SystemairCAD based on the actual data of the designed unit.

## Ecodesign Directive

The Ecodesign Directive 1253/2014 prescribes minimum requirements regarding heat recovery efficiency, fan efficiency, SFP internal values, and operation of the air handling unit. The selection software SystemairCAD is updated with an automatic Ecodesign calculation that will tell you if the requirements are fulfilled.

## Machinery directive

Geniox air handling units are manufactured according to the safety demands of the EU Machinery Directive 2006/42/EC. This is confirmed through the issuance of corresponding Declaration of Conformity and CE label.

## Eurovent Certified Performance for Hygienic Air Handling Units (ECP HAHU)

All application areas are covered through 2 star rating. Includes requirements from the VDI 6022-1, DIN 1946-4 and other national standards, such as HTM 03-01.

### VDI 6022-1

Systemair's products are certified in accordance with the code of practice VDI 6022-1. VDI is an abbreviation of Verein Deutscher Ingenieure (Association of German Engineers). An accredited certification according to VDI6022-1 guarantees that the product meets the market's most stringent hygiene requirements.

Modular Geniox air handling units undergo third party audits by SYNLAB in Germany, a European leader in clinical laboratory services. SYNLAB has issued the VDI 6022-1 test report and certificate.

### Eurovent Summerlabel

Energy Efficiency Classes for Summer Application (EECS) label for air handling units (AHUs). Includes cooling and accommodates warmer weather conditions. The summer label is available to our entire range of Eurovent-certified AHUs.

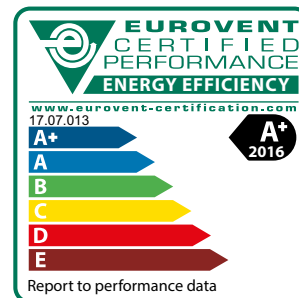
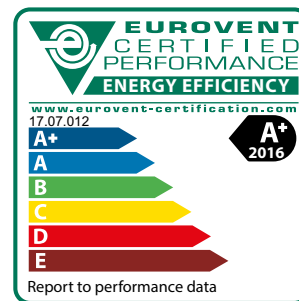

# Standards

The Geniox design is based on the demands in the following CEN, UL and ISO standards:

**AHRI 410**

Forced-Circulation Air-Cooling and Air-Heating Coils.

**AHRI 1060**

Performance Rating of Air-to-Air Heat Exchangers for Energy Recovery Ventilation Equipment.

**AMCA 300**

Test Code for Sound Rating Air Moving.

**AMCA 500**

Test Methods for Louver, Dampers and Shutters.

**ASHRAE 62**

Ventilation for Acceptable Indoor Air Quality.

**ASHRAE 84**

Method of Testing Air-to-Air Heat Exchangers.

**ASHRAE 90.1**

Energy Standard for Buildings Except Low-Rise Residential Buildings.

**ASHRAE 111**

Measurement, Testing, Adjusting and Balancing of Building HVAC Systems.

**CSA C22.2, No.236**

Heating and Cooling Equipment.

**EN 307:1997**

Heat exchangers. Definition and test procedures.

**EN 308:2022**

Heat exchangers. Test procedures.

**EN 378-1&2:2016**

Refrigerating systems and heat pumps safety and environmental requirements.

**EN ISO 16890**

Air filters for general ventilation.

**EN 1216:1999**

Heat exchangers.

**EN 1751:2014**

Aerodynamic testing of dampers and valves.

**EN 1886:2008**

Air handling units. Mechanical performance.

**EN 13053:2011**

Ratings and performance for units and components.

**EN 16783-3:2018**

Ventilation for non-residential buildings. Performance requirements.

**EN 60204-1:2006**

Machine safety. Electrical equipment of machines.

**EN ISO 3741:2010**

Determination of sound power level in reverberation rooms.

**EN ISO 5136:2009**

Determination of sound power level in a duct.

**EN ISO 12100:2011**

Safety of machinery.

**EN ISO 12944-2:2000**

Corrosion protection. Classification of environments.

**DS 428:2019**

Danish Standard for fire technical precautions, indoor air handling units comply with class A2-s1,d0.

**NFPA 70**

National Electrical Code (NEC).

**NFPA 90A**

Standard for the Installation of Air Conditioning and Ventilation Systems.

**UL 94**

Air handling units. Test for Flammability of Plastic Materials for Parts in Devices and Appliances.

**UL 723**

Standard for Test for Surface Burning Characteristics of Building Materials.

**UL900**

Standard for Air Filters.

**UL 1995**

Standard for Heating and Cooling Equipment.

# Indoor unit

The Geniox air handling unit is available for indoor installation.



---

## Function

For the indoor installation, Geniox's modular platform is based on standardized sections that fit seamlessly together – making numerous configurations possible. This level of flexibility means that we can offer an optimized solution regardless of your project and industry.

## Minimal energy loss and durable design

The casing with L1(M) leakage class further increases the unit's already high energy efficiency – minimizing heat loss and thermal bridges. In combination with the latest fan technology, this means the highest operating efficiency and energy saving for your project. It also reduces the sound, which is vitally important in indoor installations. You get more freedom of choice for the placement of the unit.

---

# Outdoor unit

The Geniox air handling unit is available as a roof unit for outdoor installation.



---

## Function

For the outdoor installation the unit is assembled on a base frame and features a roof construction which together with the double sealing of the panels provides protection against the effects of the weather. The roof unit can be delivered with two different types of roof:

### Bitumen membrane roof

Manufactured of polyester, reinforced bitumen material fitted to the unit by a heating process. The bitumen roof is a very close and robust roofing completely finished from factory.

### Steel profile roof

Air intake and exhaust are available with louvers for effective protection against rain and snow. We recommend placing the exhaust air on the back of the unit by adding an outdoor air section. Exhaust can also be placed above air intake in the end of the unit.

# Plug fan

The plug fan is built into an acoustically insulated air handling unit.



EC plug fan



AC plug fan

## Construction

Single inlet plug fan with open outlet into the air handling unit. The impeller is fitted with air foiled blades to obtain the highest possible efficiency. The fan is a single inlet, free-blowing fan where the unit casing acts as fan housing. Static efficiency up to 75%. To optimize the plug fan efficiency in the operating point, the fans can be selected in several variations:

- S:** Small impeller (low airflow)
- M:** Medium impeller (medium airflow)
- L:** Large impeller (high airflow)

## Variants

The plug fan comes in two variants:

### EC

Compact plug fan with an effective composite impeller, where all details are optimised in order to achieve a high efficiency. The impeller is fitted directly to an EC external rotor motor with integrated variable speed control. The EC motor is in efficiency class IE5. An EC motor is characterized by a high efficiency and excellent control features. Several fans can be positioned in parallel operation at larger units. The fans are mounted on the end wall of the fan section.

### AC

Plug fan with an effective impeller fitted to the motor shaft. Depending on size, the impeller is made of composite material or painted steel. The AC motors are stepless controllable via frequency converter. Two fans can be positioned in parallel operation at larger units. The fans are mounted on vibration steel springs on the bottom of the fan section.

**The AC fan can be supplied with two types of motors for 3 x 400 V AC.**

**AC: Induction – asynchronous motor. Efficiency class IE3 according to EN 60034-30:2009. One frequency converter controls parallel operation of twin fans.**

### Positioning in the air handling unit

A plug fan supplies air at the fan section outlet with a low and even air speed. Therefore, it is an advantage to position air handling components on the outlet side of the fan.

## Service-friendly

The plug fan has a large inspection door providing easy access for service. The plug fan AC in sizes 10-14 has the fan and motor assembled on guide rails, which allow easy extraction from the unit.

## Sound data

The design program SystemairCAD calculates the fan sound power level  $L_w$  (ref. 1 pW). The calculations are based on measurements carried out according to the following standards:

- EN ISO 5136:2009, Determination of sound power level in a duct.
- EN ISO 3741:2010, Determination of sound power level in reverberation rooms.

SystemairCAD also calculates the sound power levels for all duct connections to the unit.

## Kitchen fan option

Our fan motor in the extract air is protected from grease and moisture from the kitchen air by placing the motor in its own casing. An outdoor air intake to the motor ensures that it is cooled. This air is then led through the fan wall to the fan's negative pressure side. It is extracted from here along with the exhaust air. This solution creates the best possible conditions for our motor by avoiding grease build-up and at the same time ensuring that the motor is cooled.

The frequency converter must be placed outside the extract air from the kitchen.



### Balancing

The fan is balanced both statically and dynamically.

### Operating temperatures

General temperatures for air in the air handling unit:

**Standard design: -40/+104 °F**  
**-40/+40 °C**

**Special design: -40/+140 °F**  
**-40/+40 °C.**

### Airflow calculation

The inlet cone is equipped with a pressure nozzle. This can be used to determine the current airflow using the K-factor and the formula:

$$V = \sqrt{\Delta P_m} \times K$$

V = Airflow in m<sup>3</sup>/h

ΔP<sub>m</sub> = Measured pressure in Pa (according to sketch)

K = K-factor for the current fan (according to table).

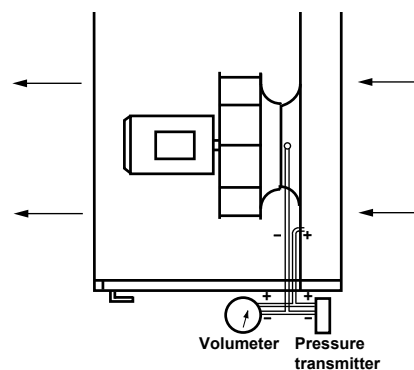

### Plug fan EC

Impeller ø mm	Material	K-factor	Fan type EC
250	Composite	67	10-S, 11-S
280	Composite	85	10-M
310	Composite	106	10-L, 11-M, 12-S
350	Composite	140	11-L, 12-M, 14-S
400	Composite	180	12-L, 14-M, 16-S
450	Composite	220	14-L, 16-M, 18-S
500	Composite	280	16-L, 20-S
560	Composite	355	18-M, 20-M, 22-S
2x450	Composite	440	18-L, 20-L, 22-M, 24-S
2x500	Composite	500	27-S
2x560	Composite	710	22-L, 24-M, 27-M, 29-S
3x500	Composite	840	24-L, 27-L, 29-M, 31-S, 38-S
3x560	Composite	1065	29-L, 31-M, 35-M, 41-S
4X500	Composite	1120	31-L, 38-M, 44-S
3x450	Composite	660	35-S
4X560	Composite	1420	35-L, 41-M
5X560	Composite	1775	35-XL, 38-L, 41-L, 44-M
6X560	Composite	2130	38-XL, 44-L
7X560	Composite	2485	41-XL
8X560	Composite	2840	44-XL

### Plug fan AC

Impeller ø mm	Material	K-factor	Fan type AC
220	Steel	47	10-S,
250	Composite	60	10-M, 11-S
280	Composite	75	10-L, 11-M
310	Composite	95	11-L, 12-S
350	Composite	121	12-M, 14-S
400	Composite	154	12-L, 14-M, 16-S
450	Composite	197	14-L, 16-M, 18-S
500	Composite	252	16-L, 18-M, 20-S
560	Composite	308	18-L, 20-M, 22-S
2x450	Composite	394	20-L
630	Composite	381	22-M, 24-S
2x500	Composite	504	22-L, 24-M, 27-S
2x560	Composite	616	24-L, 27-M, 29-S
2x630	Composite	762	27-L, 29-M, 31-S
2x710	Steel	980	29-L, 31-M, 35-L, 44-S
2x800	Steel	1240	31-L, 35-XL, 38-L, 44-M
1x710	Steel	490	35-S
1x800	Steel	620	35-M, 38-S
1x900	Steel	789	38-M, 41-S
1x1000	Steel	999	41-M
2x900	Steel	1578	38-XL, 41-M, 44-L
2x1000	Steel	1998	41-XL, 44-XL

# Rotary heat exchanger

Regenerative heat exchanger with high efficiency.



## Versions

The rotary heat exchanger is available in 4 versions:

- A** Highest heat recovery solution
- B** Good heat recovery balanced with medium pressure drop
- C** Medium heat recovery with low pressure drop
- D** Lowest pressure drop solution

## Variants

The rotary heat exchanger is available in 3 variants: Condensation, sorption hybrid, and sorption heat exchanger.

### ST - Condensation heat exchanger:

**Winter** This variant is mainly used for recovery of heat from the extract air. However, there may also be recovered moisture from the extract air through condensation at low outdoor temperatures. Moisture transfer is excellent at temperatures colder than 10°F (-12°C).

**Summer** Recovery of cooling energy from the return air. Available in version: A, B, C, and D.

### SH - Sorption hybrid exchanger:

**Winter** At milder temperature down to 10°F (-12°C) this variant has a hygroscopic surface so that recovery of heat and moisture is possible before condensation. In this way, high return air enthalpy content can contribute to the heating and humidification of the supply air.

**Summer** Recovery of cooling energy from the return air and light dehumidification of outdoor air before cooling. Available in version: A, B, and D.

### HM - Sorption heat exchanger:

**Winter** At milder temperature down to -10°F (-12°C) this variant has a recovery of heat and moisture from the return air. In this way, high return air enthalpy content can deliver a large contribution to the heating and humidification of the supply air.

**Summer** Recovery of cooling energy from the return air and dehumidification of outdoor air before cooling. Large power savings for cooling can be achieved hereby as less energy is required for condensation loss on the cooling coil. Available in version: A, B, C, and D.

## Rotor

The rotor is made with a hub with bearings and two layers of aluminium. The first layer is smooth and the second is corrugated. The two layers are rolled up to the required outer diameter, and then fixed in a very stable construction. The height of the corrugation determines the pressure drop as well as the mass of the rotor and thus also the efficiency. Foil width is 7.9" (200 mm).

## Sealing

In order to safeguard against leakage between the airflows, the heat exchanger is fitted with highly effective brush type seals.

## Service-friendly

The heat exchanger is equipped with a large inspection door. The exchangers in sizes Geniox 10 to 16 can be pulled out for inspection.

## Division of large heat exchangers

On account of transport the exchangers from size 22 can be supplied divided in the height.

The lower half of the exchanger and the hub of the rotor are assembled into the lower half of the AHU casing. All other parts of the heat exchanger are supplied for local assembly.

## Purging sector

The exchanger is with a purging sector that flushes the rotor matrix with outside air before it rotates into the supply air duct. In this way only outside air is present in the matrix, and the carry over of exhaust air to supply air is minimized.

## Drive system

An electronic control unit and a slow rotating motor drive the exchanger. This provides an accurate and stepless regulation of the rotor speed. In this way the exchanger efficiency is controlled. The drive system can also be set up for constant speed. In this way the exchanger provides full heat recovery when it is in operation.

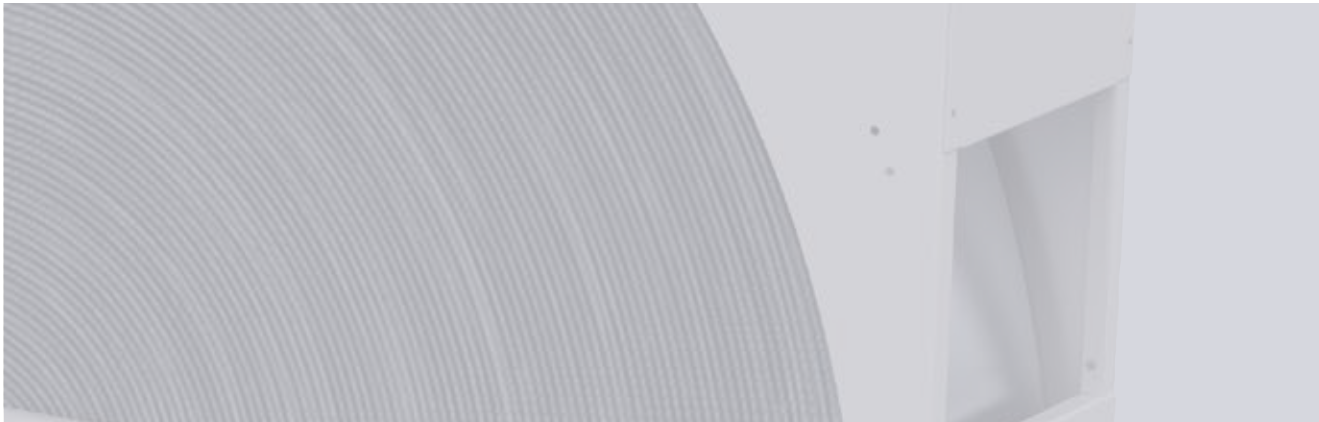

### Mains connection

1 x 230 V, 50/60 Hz.

### Operation indication

The control unit has a LED that indicates the actual operating situation.

### Control signal

The control unit can be regulated by an external 0-10 VDC control signal. For condensation and sorption hybrid heat exchanger 0-10 V corresponds to 0-12 rpm, and for sorption heat exchanger to 0-20 rpm.

### Alarm connections

Built-in relay for connection to an alarm system. By an undesirable operating situation an alarm is triggered.

### Protection

Built-in protection against unstable voltage supplies from the mains. Built-in overcurrent protection, which protects the motor against overloading.

### Rotary alarm switch

Built-in system for monitoring the rotor operation position. Gives a signal by way of an alarm connection, if the rotor operation is interrupted unintentionally.

### Purging

Outside of the normal operating period the rotor is turned slowly 12 sec. every 15 min. in order to purge the rotor with clean air.

### Cooling recovery

The heat exchanger can be activated for the recovery of cooling energy via the external control signal.

### EATR control

The EATR (Extract Air Transfer Ratio) ensures optimal pressure ratio between extract air and supply air. The function secures a lower negative pressure in the return air compared to supplied air. The EATR control function reduces leakage from the return air to the fresh supply air when using of rotary heat exchangers.

## Data for rotor drive system, condensation and sorption hybrid exchangers

Unit size	Motor			Control unit			
	Type	Torque, Nm	Power, W	Type	Voltage, V	Current, A	Max. fuse
10-18	90 TYD-M	2.8	85	RHC 200	1 x 230	0.4	10 A
20-31	120 TYD-M	5.5	145	RHC 200	1 x 230	0.6	10 A
35-44	EMX-D Motor	26	750 W	Emotron EMX-D	1x230	Max. 3.5 A	10 A

## Data for rotor drive system, sorption heat exchanger

Unit size	Motor			Control unit			
	Type	Torque, Nm	Power, W	Type	Voltage, V	Current, A	Max. fuse
10-14	90 TYD-M	2.8	85	RHC 200	1 x 230	0.4	10 A
16-22	120 TYD-M	5.5	145	RHC 200	1 x 230	0.6	10 A
24-31	120 TYD-L	7.5	370	RHC 200	1 x 230	1.6	10 A
35-44	EMX-D Motor	26	750 W	Emotron EMX-D	1x230	Max. 3.5 A	10 A

# Plate heat exchanger

Recuperative plate heat exchanger with high efficiency.



Cross flow heat exchanger



Counter flow heat exchanger

## Application

The plate heat exchanger is used where there are special requirements for separation of the two airflows. The heat exchangers are made of seawater resistant aluminum for use in environments where no corrosive elements are present in the air to corrode aluminum.

## Variants

The plate heat exchanger is available in two variants: Cross flow and Counter flow. It has separated airflows, and thus the transfer of odors to the supply air is avoided.

### Cross Flow Heat Exchanger (x)

The cross flow exchanger has an efficiency of up to 85% depending on air speed and unit size. It is made of aluminium for comfort.

- Available in type A, B & C, with A being the most heat recovering efficient.
- Unit sizes 10-31.

### Counter Flow Heat Exchanger (c)

The counter flow exchanger has a efficiency of up to 90% and is supplied only in aluminium. The heat exchangers are fitted with bypass for capacity control and for frost protection, and have a built-in drip tray with slope.

- Available in a normal and high type.
- Unit sizes 10-20.

## Versions

The cross flow heat exchanger (x) is available for Geniox 10-31 in 4 versions with different distances between the plates. This assures numerous options when dimensioning efficiency and pressure drop of the heat exchanger and therefore great flexibility when adjusting the heat exchanger. Also available in a corrosion protected version.

## Bypass

The heat exchanger is supplied with a built-in by-pass that can regulate the heat recovery from 0-100%. The by-pass function is comprised of a damper for the heat exchanger and a damper for the bypass air. The bypass function is located in the middle of the plate heat exchanger. Consequently, the heat exchanger is divided.

## Service-friendly

The heat exchanger is equipped with large inspection doors that provide access for inspection and service. As the heat exchanger has no rotating part, it requires very little service.

## De-icing and sectional defrosting

If the outdoor air is very cold, usually below 23°F (-5 °C), there is a risk of frost and ice accumulation in the exhaust air side of the exchanger. By regulating bypass dampers the exchanger can automatically defrost and prevent ice accumulation.

## Drip tray with slope

A drip tray made of stainless steel or Zinc Magnesium (ZM310) is fitted beneath the heat exchanger for collection of the water that can condense. The drip tray drain outlet must be fitted with two water traps that are designed for the actual pressure difference. Refer to the assembly instructions. Both heat exchangers are fitted with a drip tray with slope in both extract and supply air sections - 1.6" (40 mm) outlet.

**Cross flow heat exchanger (x)**

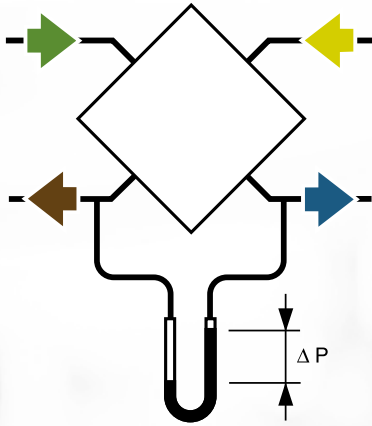

Max.  $\Delta P = 1000 \text{ Pa}$

**Counter flow heat exchanger (c)**

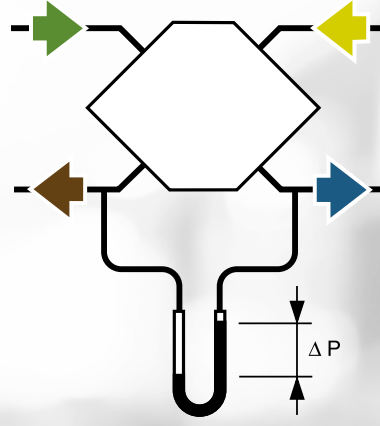

Max.  $\Delta P = 500 \text{ Pa}$

**Air direction variants  
Return air, diagonal downstream**

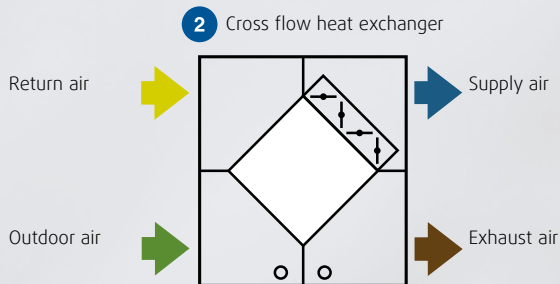
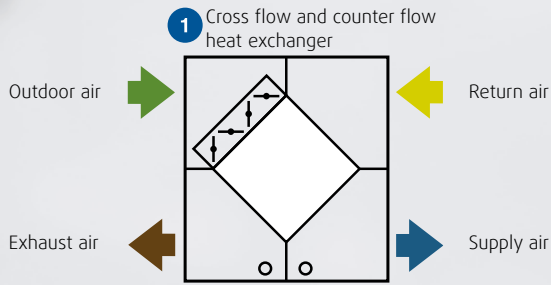

**Air direction variants  
Return air, diagonal upstream \***

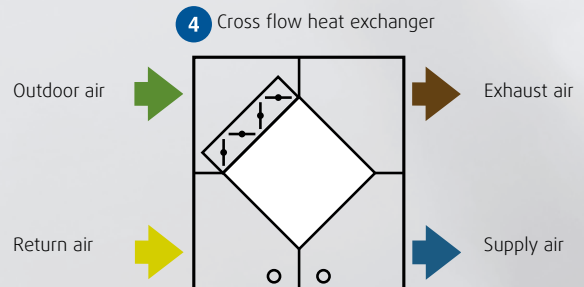
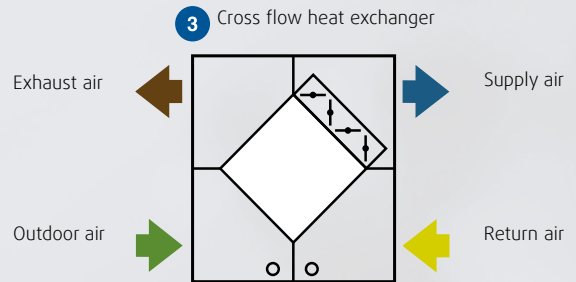

\* Air directions with upstream extract air (3 and 4) should only be used when the moisture content of the return air, before the heat exchanger, is less than the following values:

Supply air before heat exchanger °F (°C)	32°F (0°C)	14°F (-10°C)	-4°F (-20°C)	-22°F (-30°C)
Return air before heat exchanger max. g water/kg air Otherwise, there is a risk of water accumulating in the heat exchanger.	10	8	6	4

# Run-around coil heat exchangers

Heat exchanger system using two water coils to transfer via pipe system the cold/heat between return and supply units.

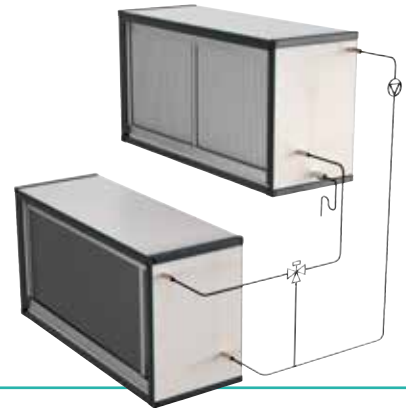

The run-around coil heat exchangers are used where it is a requirement that the two airflows must be kept completely separated, or where they are at a distance from each other. The coils must be connected with a piped circuit in which a water/glycol mixture is circulated. Efficiency  $\geq 70\%$ .

## Variants

Standard – Coil completely built into the unit.

MAX – Full size coil which is wider than the unit. Fins surface corresponds to the inside cross section area of the air handling unit.

## Construction

The heat exchanger coils consist of copper tubes with aluminum fins.

## Copper tubes

3/8", 1/2", 5/8" (Generally preferred in run-around coil systems for the whole range).

## Fin material

3/8", 1/2", 5/8" 0.11 mm and 0.20 mm Aluminum

Standard design that offer good performance compared to cost.

3/8", 1/2", 5/8" 0.11 mm and 5/8" 0.25 mm Polyester coated aluminum

Synthetic coating that gives improved corrosion resistance. Used for mildly corrosive air.

1/2" and 5/8" 0.20 mm Copper

Great conductor of heat and more corrosive resistant than aluminum. Copper tubes with copper fins has not galvanic action in the tube-fin bonds. Used for high capacities or corrosive air.

1/2" and 5/8" 0.15 mm and 5/8" 0.20 mm AlMg 2.5 aluminum

Seawater resistant aluminum. Used for corrosive air.

## Drip tray with slope

In the return air section a drip tray comes standard, a supply air drip tray is an available option.

## Droplet eliminator

The run-around coil heat exchangers are available with a droplet eliminator in the return air section as standard and in the supply air, if selected.

## Regulation

A motorized valve built into the pipe circuit regulates the heat exchanger capacity.

## Piped circuit example

Water is standard. In the supply air section it is an option. The tray is available in stainless steel and in Zinc Magnesium (ZM310). The drip tray drain outlet must be fitted with a water trap that is designed for the actual pressure difference 1.6" (40 mm) outlet. Refer to the assembly instructions.

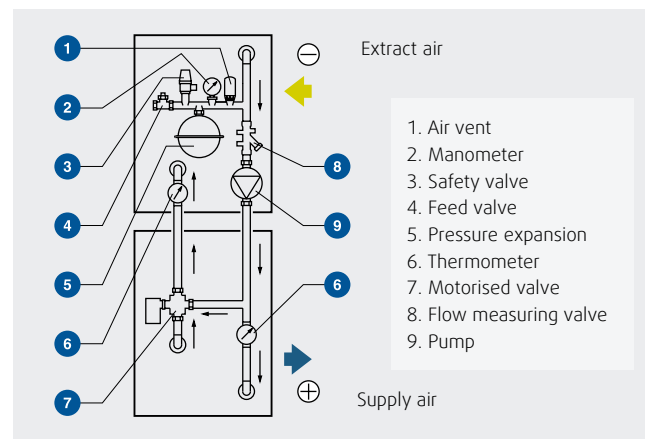

# Heating coil

Air heater

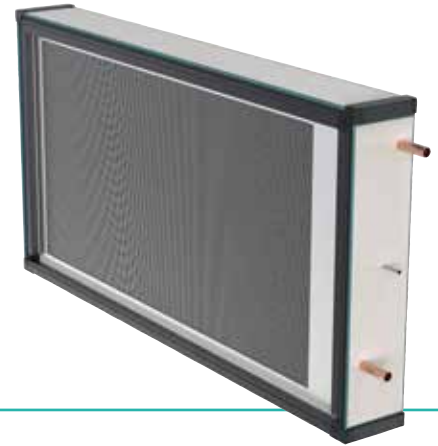

## Heating media

**W** – Hot water.

Max. temperature 212°F (100°C),  
max. working pressure 145 psi. (10 Bar.) Available for  
temperatures up to 266°F (130°C).

**C** – Condensation of refrigerant.

Max. working pressure depending on the type of  
refrigerant.

**E** – Electrical heating.

## Variants

Standard – Heating coil completely built into the unit.

MAX – Heating coil which is wider than the unit, i.e. full-  
size coil. Hot water and condensation coils only.

## Construction

Water coils and condensation coils are made of copper  
tubing and aluminum fins. Coils for electrical heating  
consist of stainless steel tube heating elements.

## Copper tubes

**P25** – 3/8"

**P3012** – 1/2"

**P40** – 5/8"

## Fin material

**3/8", 1/2", 5/8" 0.11 mm and 0.20 mm Aluminum**

Standard design that offers good performance compared  
to cost.

**3/8", 1/2", 5/8" 0.11 mm and 5/8" 0.25 mm Polyester  
coated aluminum**

Synthetic coating that gives improved corrosion resistance.  
Used for mildly corrosive air.

**1/2" and 5/8" 0.20 mm Copper**

Great conductor of heat and more corrosion resistant than  
aluminum. Copper tubes with copper fins has no galvanic  
action in the tube-fin bonds. Used for high capacities or  
corrosive air.

**1/2", 5/8" 0.15 mm and 5/8"**

**0.20 mm AlMg 2.5 aluminum**

Seawater resistant aluminum. Used for corrosive air.

## Frost protection

Heating coils for hot water are available with a connection  
piece for the fitting of a temperature sensor in the water  
circuit.

## Electrical heating

The inspection door, which can be opened only by using  
a key, provides access to a terminal box for the electrical  
connections. The coil has a built-in safety thermostat with  
an automatic reset function and an overheating thermostat  
with manual resetting.

# Cooling coil

Air cooler



The cooling coil is used for cooling the supply air. It can be effected by cold water or direct evaporative refrigerant. A cooling coil for evaporation has the liquid distributor placed in the unit.

## Cooling media

**W** – Cold water.

Max. working pressure 145 psi. (10 Bar.)

**D** – Evaporation.

Max. working pressure depending on the type of refrigerant.

## Variants

Standard – Cooling coil completely built into the unit.

MAX – Cooling coil which is wider than the unit, i.e. full-size coil to increase surface area and lower pressure drop. Connection on the outside.

## Construction

The water coils are made of copper tubing and aluminum fins.

## Copper tubes

3/8"

1/2"

5/8"

## Fin material

**3/8", 1/2", 5/8" 0.11 mm and 0.20 mm Aluminum**

Standard design that offers good performance compared to cost.

**3/8", 1/2", 5/8" 0.11 mm and 5/8" 0.25 mm Polyester coated aluminum**

Synthetic coating that gives improved corrosion resistance. Used for mildly corrosive air.

## 1/2" and 5/8" 0.20 mm Copper

Great conductor of heat and more corrosive resistant than aluminum. Copper tubes with copper fins has no galvanic action in the tube-fin bonds. Used for high capacities or corrosive air.

## 1/2", 5/8" 0.15 mm and 5/8" 0,20 mm AlMg 2.5 aluminum

Seawater resistant aluminum. Used for corrosive air.

## Pipe connections

The connection pipes for the cooling coil are placed outside of the air handling unit. The cooling coil for evaporation has the liquid distributor placed inside the unit section. The expansion valve can be fitted to the connection piece outside of the unit.

## Drip tray with slope in 3 directions

The cooling coil section is fitted with a stainless steel or Zinc Magnesium (ZM310) drip tray with slope for collection of condensed water. The drip tray drain outlet must be fitted with a water trap that is designed for the actual pressure difference (ø 40 mm outlet). Refer to the assembly instructions.

## Droplet eliminator

The cooling coil is available with a droplet eliminator that prevents condensed water droplets from being carried into the airflow.

# Change-over coil

Heating of air with hot water/glycol. Cooling of air with cold water/glycol.



The change-over coil is basically a cooling coil for cold water, which can also be used for heating by changing the water temperature from cold to warm as required.

## Heating/cooling media

**W** – Hot/cold water.

Max. working pressure 145 psi. (10 Bar.)

## Variants

Standard – Heating/cooling coil completely built into the unit.

MAX – Heating/cooling coil which is wider than the unit, i.e. full-size coil to increase surface area and lower pressure drop.

## Construction

Water coils are made of copper tubing and aluminum fins.

## Copper tubes

3/8"

1/2"

5/8"

## Fin material

**3/8", 1/2", 5/8" 0.11 mm and 0.20 mm Aluminum**

Standard design that offers good performance compared to cost.

**3/8", 1/2", 5/8" 0.11 mm and 5/8" 0.25 mm Polyester coated aluminum**

Synthetic coating that gives improved corrosion resistance. Used for mildly corrosive air.

## 1/2" and 5/8" 0.20 mm Copper

Great conductor of heat and more corrosive resistant than aluminum. Copper tubes with copper fins has no galvanic action in the tube-fin bonds. Used for high capacities or corrosive air.

## 1/2", 5/8" 0.15 mm and 5/8" 0,20 mm AlMg 2.5 aluminum

Seawater resistant aluminum. Used for corrosive air.

## Pipe connections

The connection pipes for the cooling coil are placed outside of the air handling unit.

## Drip tray with slope

The cooling coil section is fitted with a stainless steel or Zinc Magnesium (ZM310) drip tray with slope for collection of condensed water. The drip tray drain outlet must be fitted with a water trap that is designed for the actual pressure difference (ø40 mm outlet). Refer to the assembly instructions.

## Droplet eliminator

The change-over coil is available with a droplet eliminator that prevents condensed water droplets from being carried into the airflow.

## Frost protection

The heating/cooling coil is available with a connection piece for the fitting of a temperature sensor in the water circuit.

# Air humidifier

Humidifier for adiabatic cooling and humidification



The humidifier is VDI 6022 certified.

## Function

The function is based on the natural process that water evaporates when air passes a wet surface. By uptake of water vapor in the air, the temperature decreases due to heat for the evaporation from the air. This is an adiabatic cooling, which means the enthalpy content of the air is unchanged during the process. This ensures humidification occurs without releasing drops, unless this is affected by entrainment. Avoid entrainment by passing the humidification elements with a suitable low speed or by mounting droplet eliminators, which can handle this.

## Application

The humidifier can be placed in the supply air after a heating coil which can preheat the air before humidification.

## Max. air velocity is 10,000 cfm.

There may be need for an after heating coil in order to achieve the desired supply air temperature. With high outdoor temperature and low humidity, placement of the humidifier in the supply air can be used as adiabatic cooling with great advantage. Indirect adiabatic cooling can be achieved by placing it in the return air before a plate heat exchanger. It is recommended to use a corrosion-protected heat exchanger.

## Construction

The humidifier is designed to fit the internal dimensions of Geniox. The unit comprises humidification elements, tray and frame made of stainless steel, circulation pump, balancing valves for irrigation, overflow, valve for adjusting bleed off, float valve for controlling the water supply to the tray and valve for emptying the tray. Droplet eliminator is included if necessary and sensor for protection of pump at low water level. The drain is led out of the section, and can be selected on the inspection side or the backside. The drain must be connected to a water trap with sufficient locking height.

## Humidification elements

HU-CELL humidification elements are stainless steel frames which contain corrugated fiberglass plates arranged in cross-channel configuration. The configuration ensures that the air is in contact with a large surface area for evaporation, and simultaneously provides a low pressure drop.

The glass fiber material is impregnated with a stabilizing and absorbent additive which makes it possible to absorb water without loss of stability. The inorganic material is not a feed of source for bacteria and mold. The material contains silver ions, which increases the resistance to the growth of microorganisms and helps to release deposits from the water on the material. Silver ions are encapsulated in a chemical mixture, which ensures particles do not dissolve to either water or air.

Elements are supplied in the following thicknesses **3 in, 4 in, 5 in, 6 in**, which makes it possible to optimize the pressure drop depending on the desired humidification/cooling requirement.

*Control system is not supplied.*

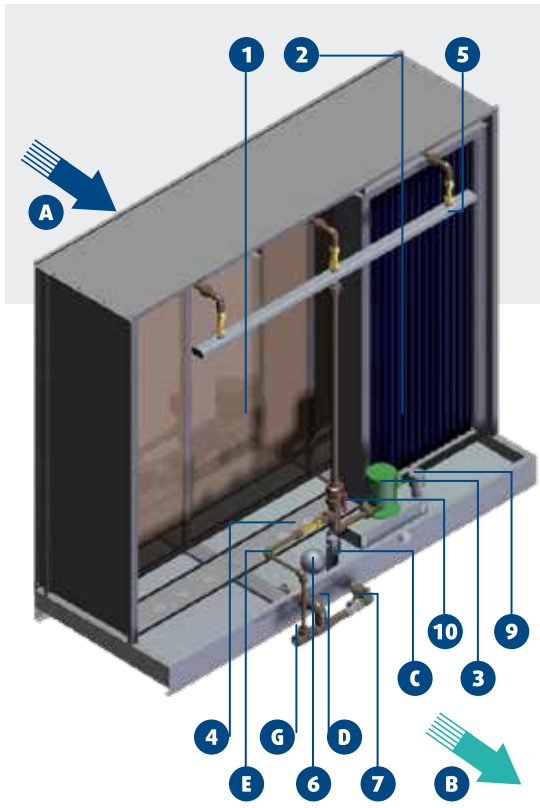

The humidifier can be step-controlled as illustrated

- A. Process air
- B. Humidified air
- C. Water supply
- D. Overflow
- E. Constant bleed off
- F. Drainage
- G. Water outlet to drain
- 1. Humidification element
- 2. Droplet eliminator (optional)
- 3. Water recirculation pump
- 4. Bleed off regulation valve
- 5. Irrigation regulation valves
- 6. Float valve
- 7. Draining valve
- 8. Filling solenoid valve (optional)
- 9. Max/min water level detector
- 10. Cut-off valve (depending on model)

Unit size	Number of stage valves/solenoid coil 24 V as standard and 230 V as an option
10	2
11	2
12	2
14	2
16	3
18	3
20	3
22	4
24	4
27	5
29	5
31	5

There are always 1 valve/solenoid coil supply water and 1 motor drain valves/solenoid coil 24 V as standard and 230 V as an option for both.

**Operating principles**  
HEF2E (Recirculated water, standard on/off)

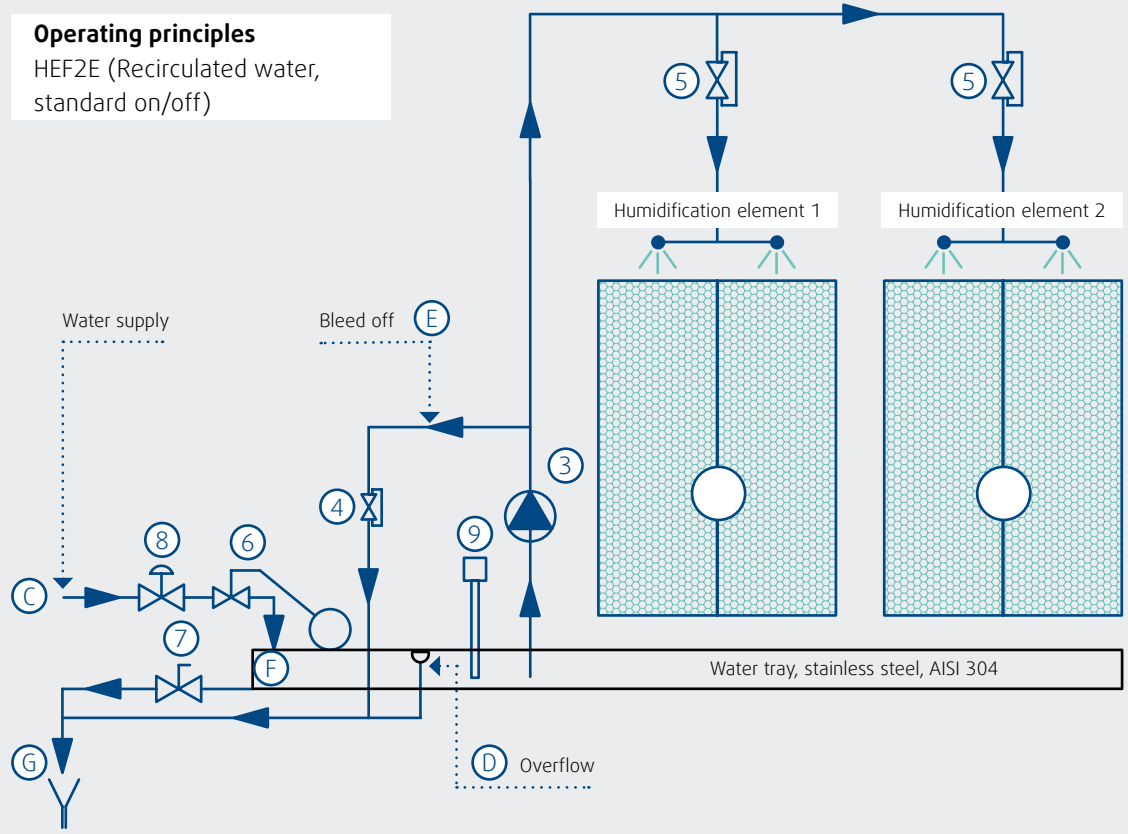

# Filter rating comparison

## Comparative guide by classification

EN 779:2012	EN 779:2012	EN 1822:2009	ASHRAE Standard 52.2 2007
Coarse Filters Average Arrestance (Am) Final Test Pressure Drop 250 [Pa]	Medium and Fine Filters Average Efficiency (Em) and Minimum Efficiency (M.E.) of 0.4 µm particles Final Test Pressure Drop 450 [Pa]	(H)EPA- and ULPA-Filters Efficiency	Minimum Efficiency Reporting Value (MERV)
50% ≤ Am < 65% <b>G1</b>			<b>MERV 1-4</b>
65% ≤ Am < 80% <b>G2</b>			<b>MERV 1-4</b>
80% ≤ Am < 90% <b>G3</b>			<b>MERV 5</b>
90% ≤ Am <b>G4</b>			<b>MERV 6-8</b>
	40% ≤ Em < 60% <b>M5</b>		<b>MERV 8-10</b>
	60% ≤ Em < 80% <b>M6</b>		<b>MERV 9-13</b>
	80% ≤ Em < 90% M.E.: 35% <b>F7</b>		<b>MERV 13-14</b>
	90% ≤ Em < 95% M.E.: 55% <b>F8</b>		<b>MERV 14-15</b>
	95% ≤ Em M.E.: 70% <b>F9</b>		<b>MERV 16</b>
		Overall Value ≥ 85% <b>E10</b>	<b>MERV 16</b>
		Overall Value ≥ 95% <b>E11</b>	<b>MERV 16</b>
		Overall Value ≥ 99.5% <b>E12</b>	
		Overall Value ≥ 99.95% <b>H13</b>	
		Overall Value ≥ 99.995% <b>H14</b>	
		Overall Value ≥ 99.9995% <b>U15</b>	
		Overall Value ≥ 99.99995% <b>U16</b>	
		Overall Value ≥ 99.999995% <b>U17</b>	

# Panel filter

Prefilter. Designed on pleated filter principle.



## Filter classification

The panel filter is a basic filter class Coarse 65% (G4) according to EN ISO 16890 with a short building length. ePM10 60% (M5).

## Filter material

Synthetic polyester fibres.

## Filter surface area

Large surface area due to the pleated filter form.

## Filter frame

Framework in cardboard (G4) or plastic (M5) encasing the filter with U-profiles of aluzinc.

## Accessories

- U-tube manometer
- Magnehelic manometer
- Pressure outlet tab
- Spare filter
- Filter guard (on/off).

Unit size	Number and size
10	1x[792x392x48]
11	2x[490x392x48]
12	1x[490x490x48] + 1x[592x490x48]
14	2x[490x592x48] + 1x[287x592x48]
16	3x[490x592x48]
18	2x[490x392x48] + 4x[592x392x48]
20	3x[592x592x48] + 3x[592x287x48]
22	6x[592x490x48] + 2x[287x490x48]
24	3x[592x592x48] + 4x[490x592x48] + 1x[490x490x48]
27	2x[592x592x48] + 8x[490x592x48]
29	6x[592x592x48] + 4x[490x592x48]
31	5x[592x592x48] + 5x[592x490x48] + 5x[592x287x48]
35	2x[287x592x48] + 5x[592x287x48] + 10x[592x592x48] + 1x[287x287x48]
38	3x[287x592x48] + 15x[592x592x48]
41	3x[287x592x48] + 18x[592x592x48]
44	3x[287x592x48] + 6x[592x287x48] + 18x[592x592x48] + 1x[287x287x48]

# Bag filter

Prefilter, medium or fine filter.  
The design provides a large filter area, a long lifetime and an overall good economy.

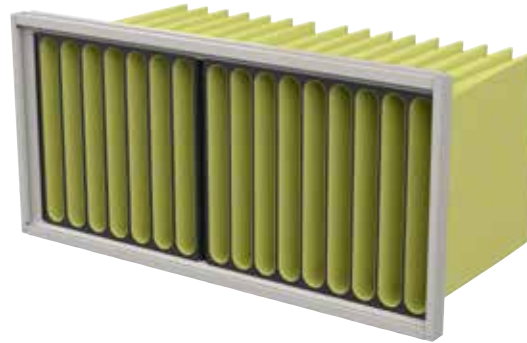

## Filter classification

The filter can be supplied in the filter classes Coarse 65% (G4), ePM10 60% (M5), ePM2.5 50% (M6), ePM1 60% (F7), ePM1 70% (F8), ePM1 85% (F9), or CITY-FLO ePM1 60% (F7 City-Flo) according to EN ISO 16890.

CITY-FLO ePM1 60% is a filter with particle and molecular filtration, specially designed for use in urban areas and areas with heavy traffic.

## Filter material

**Coarse 65% (G4):** Synthetic material. ePM10 60% (M5), ePM2.5 50% (M6), ePM1 60% (F7), ePM1 70% (F8), ePM1 85% (F9): Glass fiber material.

CITY-FLO ePM1 60% (F7 City-Flo): Glass

fiber and coal with a wide spectrum. EPM1 60% (F7), ePM1 70% (F8), ePM1 85% (F9) are available in two lengths; 520 and 640 mm.

## Filter frame

The filter cells are supplied with 25 mm standard plastic frame. Therefore, used filters can be disposed of in their entirety by combustion.

## Sealing

Rubber sealing strips are fixed to the filter cells. Air tightness according to EN 1886:2008.

## Fitting the filter cells

The cells are sealed with the enclosed sealing strips from Camfil. They are mounted on the filter profile (filter

profile by ABS and TPE) with ease in a sliding movement.

## Positioning of an ePM1 85% (F9) filter

The class ePM1 85% (F9) filter should always be positioned in the positive pressure side of the supply air unit (EN 1886:2008).

## Accessories

- U-tube manometer
- Inclined tube manometer
- Magnehelic manometer
- Pressure outlet tab
- Stainless steel bottom plate
- Spare filter set
- Inspection window
- LED-light with external switch
- Filterguard on/off

Unit size	Number and size of frames	Number of pockets in each filter cell					
		Coarse 65% L = 370 mm	ePM 10 60% L = 520 mm	ePM 2.5 50% L = 520 mm	ePM1 60%, 70% and 85% L = 520 mm	ePM1 60%, 70% and 85% L = 640 mm	CITY-FLO ePM1 60% L = 520 mm
10	1x[792x392]	12	12	12	12	12	12
11	2x[490x392]	8	8	8	8	8	8
12	1x[490x490] + 1x[592x490]	8+6	8+8	8+8	8+8	8+8	8+8
14	2x[490x592] + 1x[287x592]	5+8	5+5	8+5	8+5	8+5	8+5
16	3x[490x592]	5	5	8	8	8	8
18	2x[490x392] + 4x[592x392]	8+10	8+10	8+10	8+10	8+10	8+10
20	3x[592x592] + 3x[592x287]	6+6	6+6	10+10	10+10	10+10	10+10
22	6x[592x490] + 2x[287x490]	6+5	6+5	10+5	10+5	10+5	10+5
24	3x[592x592] + 1x[490x592] + 3x[592x490] + 1x[490x490]	6+5+6+8	6+5+6+8	10+8+10+8	10+8+10+8	10+8+10+8	10+8+10+8
27	2x[592x592] + 8x[490x592]	6+5	6+5	10+8	10+8	10+8	10+8
29	6x[592x592] + 4x[490x592]	6+5	6+5	10+8	10+8	10+8	10+8
31	5x[592x592] + 5x[592x490] + 5x[592x287]	6+6+6	6+6+6	10+10+10	10+10+10	10+10+10	10+10+10
35	2x[287x592] + 5x[592x287] + 10x[592x592] + 1x[287x287]	3+6+6+3	5+6+6+5	5+10+10+5	5+10+10+5	5+10+10+5	5+10+10+5
38	3x[287x592] + 15x[592x592]	3+6	5+6	5+10	5+10	5+10	5+10
41	3x[287x592] + 18x[592x592]	3+6	5+6	5+10	5+10	5+10	5+10
44	3x[287x592] + 6x[592x287] + 18x[592x592] + 1x[287x287]	3+6+6+3	5+6+6+5	5+10+10+5	5+10+10+5	5+10+10+5	5+10+10+5

# Virucidal Bag filter

DELTRI+ is a new generation of bag filter, which is capable of neutralizing or destroying viruses.



- For application in return air or second stage in supply air
- Stand filter configuration
- Filter class ePM1 90% (ISO 16890)
- Comparable to filter class F9 (EN 779) and MERV 16 (ASHRAE 52.2)
- Eurovent Energy Efficiency Class A+
- UL 900 certified product

Unit Size	Number of filters and filter sizes (WxHxD)	Number of filter bags
Geniox 10	2 → 1x [287x287] + 1x [592x287]	16 → 1x [5] + 1x [11]
Geniox 10	1 → 1x [792x392]	15 → 1x [15]
Geniox 11	2 → 1x [287x287] + 1x [592x287]	16 → 1x [5] + 1x [11]
Geniox 11	2 → 2x [490x392]	18 → 2x [9]
Geniox 12	2 → 1x [287x287] + 1x [592x287]	16 → 1x [5] + 1x [11]
Geniox 12	2 → 1x [490x490] + 1x [592x490]	20 → 1x [9] + 1x [11]
Geniox 14	2 → 2x [592x592]	22 → 2x [11]
Geniox 14	3 → 1x [287x592] + 2x [490x592]	23 → 1x [5] + 2x [9]
Geniox 16	3 → 1x [287x592] + 2x [592x592]	27 → 1x [5] + 2x [11]
Geniox 16	3 → 3x [490x592]	27 → 3x [9]
Geniox 18	3 → 1x [287x592] + 2x [592x592]	27 → 1x [5] + 2x [11]
Geniox 18	6 → 2x [490x392] + 4x [592x392]	62 → 2x [9] + 4x [11]
Geniox 20	6 → 3x [592x287] + 3x [592x592]	66 → 3x [11] + 3x [11]
Geniox 20	6 → 3x [592x287] + 3x [592x592]	66 → 3x [11] + 3x [11]
Geniox 22	8 → 1x [287x287] + 1x [287x592] + 3x [592x287] + 3x [592x592]	76 → 1x [5] + 1x [5] + 3x [11] + 3x [11]
Geniox 22	8 → 2x [287x490] + 6x [592x490]	76 → 2x [5] + 6x [11]
Geniox 24	8 → 1x [287x287] + 1x [287x592] + 3x [592x287] + 3x [592x592]	76 → 1x [5] + 1x [5] + 3x [11] + 3x [11]
Geniox 24	8 → 1x [490x592] + 1x [490x490] + 3x [592x490] + 3x [592x592]	84 → 1x [9] + 1x [9] + 3x [11] + 3x [11]
Geniox 27	8 → 8x [592x592]	88 → 8x [11]
Geniox 27	10 → 8x [490x592] + 2x [592x592]	94 → 8x [9] + 2x [11]
Geniox 29	10 → 2x [287x592] + 8x [592x592]	98 → 2x [5] + 8x [11]
Geniox 29	10 → 4x [490x592] + 6x [592x592]	102 → 4x [9] + 6x [11]
Geniox 31	10 → 10x [592x592]	110 → 10x [11]
Geniox 31	15 → 5x [592x287] + 5x [592x490] + 5x [592x592]	165 → 5x [11] + 5x [11] + 5x [11]
Geniox 35	18 → 1x [287x287] + 2x [287x592] + 5x [592x287] + 10x [592x592]	180 → 1x [5] + 2x [5] + 5x [11] + 10x [11]
Geniox 38	18 → 3x [287x592] + 15x [592x592]	180 → 3x [5] + 15x [11]
Geniox 41	21 → 3x [287x592] + 18x [592x592]	213 → 3x [5] + 18x [11]
Geniox 44	28 → 1x [287x287] + 3x [287x592] + 6x [592x287] + 18x [592x592]	284 → 1x [5] + 3x [5] + 6x [11] + 18x [11]

# Metal filter

Prefilter.



## Application

The metal filter is used as a prefilter in the return air, where there may be grease particles in the air. However, there should always be a grease filter in the cooker hood. The metal filter is also efficient as a prefilter where there is dust, sand, flour, paint or oil in the outdoor air.

## Filter class

G2 according to EN ISO 16890.

## Filter material

The filter cells are made from electro-galvanized aluminum thread that is weaved together.

## Filter area

Very large surface, without additional air resistance.

## Filter frame

Stainless steel.

## Cleaning

Washable.

## Accessories

- U-tube manometer
- Magnehelic manometer
- Filter guard (on/off)
- Spare filter
- Pressure outlet tab

Unit size	Number and size
10	1x[792x392x40]
11	2x[490x392x40]
12	1x[490x490x40] + 1x[592x490x40]
14	2x[490x592x40] + 1x[287x592x40]
16	3x[490x592x40]
18	2x[490x392x40] + 4x[592x392x40]
20	3x[592x592x40] + 3x[592x287x40]
22	6x[592x490x40] + 2x[287x490x40]
24	3x[592x592x40] + 4x[490x592x40] + 1x[490x490x40]
27	2x[592x592x40] + 8x[490x592x40]
29	6x[592x592x40] + 4x[490x592x40]
31	5x[592x592x40] + 5x[592x490x40] + 5x[592x287x40]
35	2x[287x592x40] + 5x[592x287x40] + 10x[592x592x40] + 1x[287x287x40]
38	3x[287x592x40] + 15x[592x592x40]
41	3x[287x592x40] + 18x[592x592x40]
44	3x[287x592x40] + 6x[592x287x40] + 18x[592x592x40] + 1x[287x287x40]

# Carbon filter

Supply air, recirculation, or exhaust filter.



## Application

A molecular filter for high efficiency and long term control of molecular pollution in sensitive buildings and the processing industry. The carbon filter is effective against airborne molecules, such as odors, Volatile Organic Components (VOCs), toxic gasses, and corroding elements. The filter can also be used as a recirculation or exhaust filter.

## Filter material

Carbon type CEX003 in a cylindrical cartridge.

- Length 18" (450 mm).
- Contact time should range between 0.1 and 0.2 sec.

## Filter cartridge

Cartridge frame in solid cast plastic.

## Limit values

Temperature: -4 - +140 °F (-20 - +60 °C)

Humidity: RH max. 70%

Recommended contact depends on the contamination in the air. Usually 0.1 to 0.2 sec. (Shown on SystemairCAD printout).

## Placement

To ensure that the filter does not get dirty, you should always place an ePM1 60% (F7) filter in front of the carbon filter. The carbon filter is typically placed as a prefilter in the supply air.

## Accessories

- Spare filter
- Inspection window
- LED light with external switch.

Unit size	Type	Number of cartridges
10	F 10 Carbon (CamCarb Green CG 2600-CEX003)	10
11	F 11 Carbon (CamCarb Green CG 2600-CEX003)	18
12	F 12 Carbon (CamCarb Green CG 2600-CEX003)	21
14	F 14 Carbon (CamCarb Green CG 2600-CEX003)	32
16	F 16 Carbon (CamCarb Green CG 2600-CEX003)	36
18	F 18 Carbon (CamCarb Green CG 2600-CEX003)	55
20	F 20 Carbon (CamCarb Green CG 2600-CEX003)	72
22	F 22 Carbon (CamCarb Green CG 2600-CEX003)	84
24	F 24 Carbon (CamCarb Green CG 2600-CEX003)	98
27	F 27 Carbon (CamCarb Green CG 2600-CEX003)	128
29	F 29 Carbon (CamCarb Green CG 2600-CEX003)	136
31	F 31 Carbon (CamCarb Green CG 2600-CEX003)	162
35	F 35 Carbon (CamCarb Green CG 2600-CEX003)	180
38	F 38 Carbon (CamCarb Green CG 2600-CEX003)	216
41	F 41 Carbon (CamCarb Green CG 2600-CEX003)	252
44	F 44 Carbon (CamCarb Green CG 2600-CEX003)	294

# Damper

The dampers can be used as shut-off dampers for supply, return, exhaust, and outdoor air. The dampers can also be used for mixing and recirculation.



The damper is VDI 6022 certified.

## Air tightness classification

The dampers comply with tightness class 4 C according to EN 1751:2014.

- Class 4 (leakage through a closed damper).
- Class C (casing leakage).

According to EN 1751:2014.

## Bearings

Synthetic bearings with large bearing surfaces.

## Sealing

Rubber sealing strips between the damper blades. Special sealing between frame and damper blades.

## Shafts

0.47" (12 mm) steel

## Blade pivoting system

Composite gears combined with steel rods.

## Blade position indicator

Arrow for indication of the blade position.

## Damper motor

The dampers are activated by 1 or up to 4 motors depending on damper sizer.

## Motor bracket

Bracket for fixing of a damper motor for each damper.

## Damper types

There are four types of dampers for each unit size. The dampers can be placed in end, top, or back of the unit and between airflows, allowing high flexibility.

Damper type	Internal in unit
1	"Full face, top, and end of unit. Geniox 10-24 one damper motor, Geniox 27-35 two damper motors Geniox 38-44 four damper motors"
2	"Full face, top, and end of unit. Geniox 10-24 one damper motor, Geniox 27-44 two damper motors"



**Dampers external on unit – Duct connection sizes, 0.79" (20 mm) flange connection**

Damper type		10	11	12	14	16	18	20	22	24	27	29	31
1	W	29.5	33.5	37.4	45.3	53.1	61.0	68.9	76.8	84.6	-	-	-
	H	15.7	15.7	19.7	23.6	27.6	31.5	35.4	39.4	43.3	-	-	-
2	W	29.5	33.5	37.4	45.3	53.1	61.0	68.9	76.8	84.6	-	-	-
	H	7.9	7.9	11.8	11.8	15.7	15.7	19.7	19.7	23.6	-	-	-
3	W	31.5	35.4	39.4	47.2	55.1	63.0	70.9	-	-	-	-	-
	H	15.7	15.7	19.7	23.6	27.6	31.5	35.4	-	-	-	-	-
4	W	15.7	15.7	19.7	23.6	27.6	31.5	35.4	39.4	43.3	47.2	51.2	55.1
	H	15.7	15.7	19.7	23.6	27.6	31.5	35.4	39.4	43.3	47.2	51.2	55.1

Dimensions are in inches

**Dampers internal in unit – Duct connection sizes**

Damper type		10	11	12	14	16	18	20	22	24	27	29	31	35	38	41	44
1	W	39.4	43.3	47.2	55.1	63.0	70.9	78.7	86.6	94.5	106.3	114.2	122.0	133.9	133.9	157.5	157.5
	H	15.7	17.7	19.7	23.6	27.6	31.5	35.4	39.4	43.3	47.2	51.2	55.1	63.0	74.8	74.8	78.7
2	W	39.4	43.3	47.2	55.1	63.0	70.9	78.7	86.6	94.5	106.3	114.2	122.0	133.9	133.9	157.5	157.5
	H	11.8	11.8	15.7	15.7	19.7	19.7	23.6	23.6	27.6	27.6	31.5	31.5	35.4	39.4	39.4	43.3

Dimensions are in inches

**Required torque (Nm) for each damper motor with varying pressure drops**

Pressure drop	10	11	12	14	16	18	20	22	24	27	29	31
0 in.wg. (0 Pa)	4	5	6	7	8	9	11	12	14	15	17	18
2 in.wg. (500 Pa)	7	8	10	11	13	14	16	17	19	21	23	24
4 in.wg. (1000 Pa)	9	11	13	15	17	19	20	22	24	26	28	29

# Sound attenuator

The sound attenuator is used to reduce the sound power level from the air handling unit to the duct system.



## Construction

The sound attenuator is an absorption attenuator with baffles made of rockwool. The baffles are surface treated in order to prevent the absorption material fibres from being carried away. Is also available for installation on duct.

## Variants

Baffles with standard lining. Each baffle is enclosed in an Aluzinc frame.

1. Baffles with standard lining for dry cleaning. The air handling unit casing has large inspection doors for easy cleaning.
2. Baffles with a synthetic lining, ideal for wet cleaning. Each baffle is enclosed in a stainless steel frame. The air handling unit casing has large inspection doors for easy cleaning.

Attenuation dB	Mid-frequency Hz							
	63	125	250	500	1000	2000	4000	8000
Geniox, length 24" (600 mm)	3	7	11	18	29	32	29	20
Geniox, length 35" (900 mm)	5	11	17	25	36	39	36	28
Geniox, length 47" (1200 mm)	7	15	23	32	43	46	42	36
Geniox, length 59" (1500 mm)	9	18	28	39	50	53	48	41
Geniox, length 71" (1800 mm)	10	21	34	46	55	58	54	47

# Duct connection part

The connection part is used when connecting duct work to the Geniox air handling unit, either as rigid connection or as rigid and flexible connection.



## Dimensions

Unit size			10	11	12	14	16	18	20	22	24	27	29	31	35	38	41	44
Variants	End of unit	D	39.4	43.3	47.2	55.1	63.0	70.9	78.7	86.6	94.5	106.3	114.2	122.0	133.9	133.9	157.5	157.5
		E	15.7	17.7	19.7	23.6	27.6	31.5	35.4	39.4	43.3	47.2	51.2	55.1	63.0	74.8	74.8	86.6
	Top half face	D	39.4	43.3	47.2	55.1	63.0	70.9	78.7	86.6	94.5	106.3	114.2	122.0	133.9	133.9	157.5	157.5
		E	11.8	11.8	15.7	15.7	19.7	19.7	23.6	23.6	27.6	27.6	31.5	31.5	35.4	39.4	39.4	43.3
	Top full face	D	39.4	43.3	47.2	55.1	63.0	70.9	78.7	86.6	94.5	106.3	114.2	122.0	133.9	133.9	157.5	157.5
		E	19.7	19.7	23.6	27.6	31.5	35.4	39.4	43.3	47.2	51.2	55.1	59.1	63.0	74.8	74.8	78.7
	Back of unit	D	23.6	23.6	27.6	35.4	35.4	43.3	43.3	51.2	51.2	59.1	66.9	74.8	70.9	70.9	82.7	82.7
		E	19.7	21.7	23.6	27.6	31.5	35.4	39.4	43.3	47.2	51.2	55.1	59.1	66.9	78.7	78.7	90.6

Dimensions are in inches

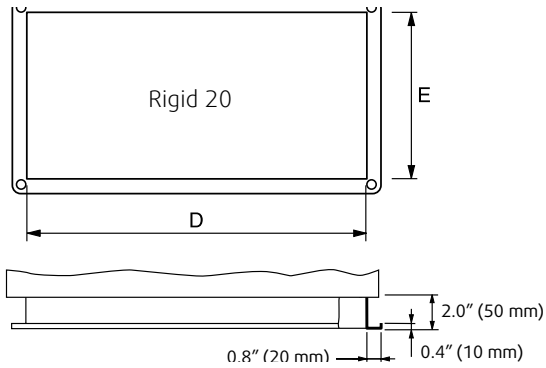

Rigid connection part for connecting to 0.8" (20 mm) LS profile for C-rail, and for 0.8 (20 mm) EP/LSM profile with holes in the corners.

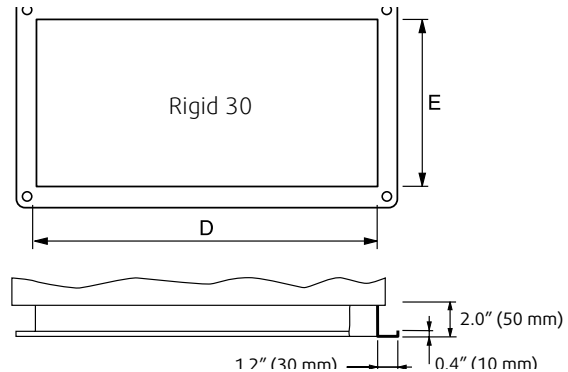

Rigid connection part for connecting to 1.2" (30 mm) EP/LSM profile with holes in the corners.

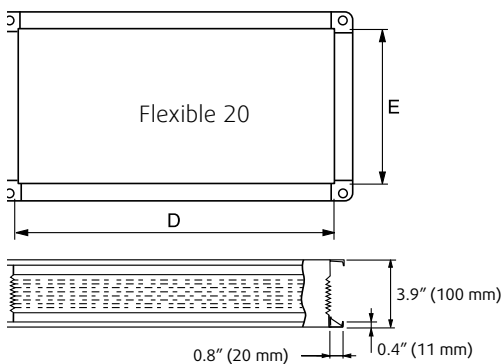

Flexible connection part for connecting to 0.8" (20 mm) EP/LSM profile with holes in the corners. For mounting in continuation of rigid connection part.

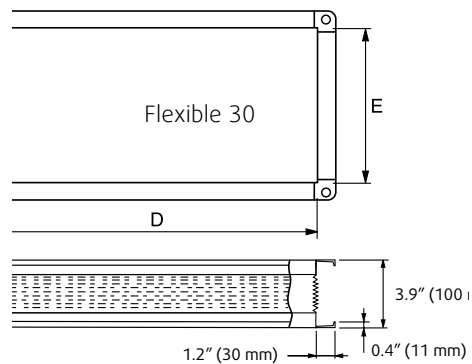

Flexible connection part for connecting to 1.2" (30 mm) EP/LSM profile with holes in the corners. For mounting in continuation of rigid connection part.

## Inspection section

The inspection section is used where the option of service, inspection, or measuring is required, before or after an air handling function.



### Construction

The inspection section consists of an empty unit casing with an inspection door.

### Accessories

- Inspection window fitted into the inspection door.
- LED lamp with external switch.
- Pressure outlet tab.

## Empty section

Used in units where space is required to fit a component, e.g. a temperature sensor, or to have the option of applying an extra air handling function at a later date.



### Construction

The empty section consists of an empty unit casing, where the side panels are assembled with screws.

### Accessories

- Inspection window fitted into the inspection door
- LED lamp with external switch.
- Pressure outlet tab.

## Supporting legs

Units in sizes Geniox 10-18 for indoor installation can be supplied with supporting legs.



### Construction

Supporting legs are made of Zinc Magnesium (ZM310). Pre-painting in RAL 7024 of the supporting legs is an option. They are 4.6" (118 mm) high, and have feet which are adjustable from 1.2"-2.2" (30-55 mm).

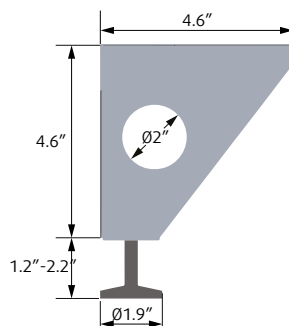

## Assembly brackets

The assembly bracket is designed to ensure an airtight connection between the casing sections.



### Assembly brackets

For air handling units divided in sections, the assembly brackets are mounted externally. Screws and nuts are delivered separately. For air handling units mounted on a base frame and assembled in the factory, the assembly brackets are mounted inside the unit. The brackets ensure that the sections are aligned at the end of the assembly.

### Construction

The brackets are made of zinc and pre-painted in dark grey.

# Outdoor air section

The outdoor air section is used for air intake and outlet in roof units.



## Function

The outdoor air section has air intake through the end of the unit, and outlet of exhaust air through the back wall of the unit.

## Construction

The outdoor air section consists of an air handling unit casing with inspection door. The openings for air intake and outlet have louvers for effective protection against rain and snow.

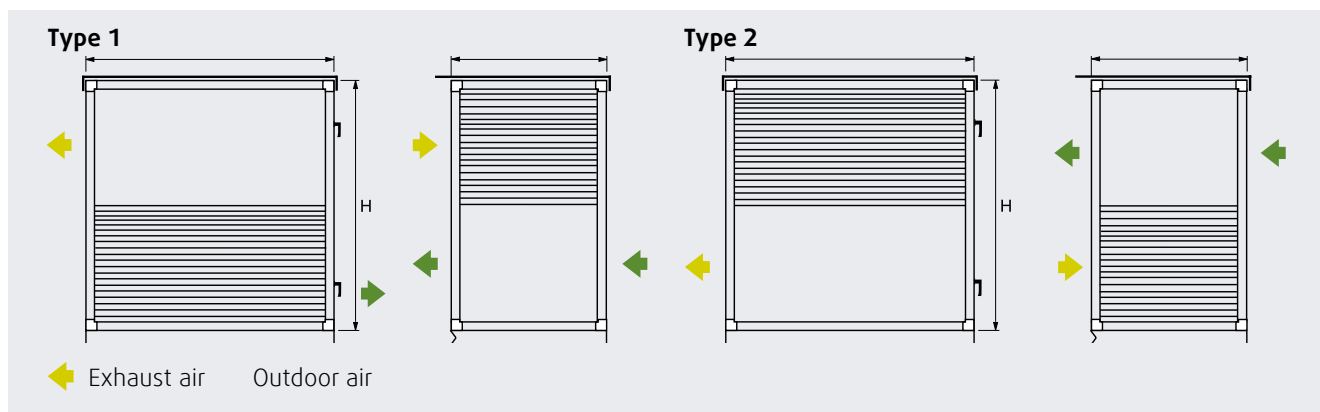

## Dimensions

Unit size		10	11	12	14	16	18	20	22	24	27	29	31
Width	W	42.6	46.5	50.5	58.3	66.2	74.1	82.0	89.8	97.7	109.5	117.4	125.3
Height	H	42.6	46.5	50.5	58.3	66.2	74.1	82.0	89.8	97.7	108.8	116.7	124.6
Length	L	23.6	23.6	31.5	35.4	39.4	43.3	47.2	51.2	55.1	59.1	66.9	74.8

Dimensions are in inches

# Standard base frame and base frame with high legs



Standard base frame



Base frame with high legs

## Standard base frame

Units for indoor installation can be supplied with base frame in height 4.6" (118 mm) with  $\varnothing$  2" (50 mm) holes or 8.6" (218 mm) with  $\varnothing$  3" (80 mm) holes. The base frame has feet which are adjustable from 1.2"-2.2" (30-55 mm).

Minimum length of base frame is 16" (400 mm). Maximum length of the base frame is 236" (6000 mm) for units Geniox 10-24 and 181" (4600 mm) for units Geniox 27-31. Longer units are supplied divided on two or more base frames. The base frame is self-supporting, but as a minimum it must be supported in each corner and on the longitudinal profiles for each 59" (1500 mm).

## Construction

The base frame consists of strong, galvanized steel profiles, 5" (118 mm) or 8.6" (218 mm) height assembled with bolts. The unit can be delivered installed on the base frame from factory, or the base frame can be delivered separately.

Base frame is coated with ZM310 metallic coating, which provides exceptional corrosion protection.

## Base frame with high legs

It is possible to choose additional high legs for base frames. These legs will always be 9.8" (250 mm) high and they will be delivered with feet which can be adjusted 4.7" (120 mm). This facilitates easy access for cleaning under the unit. The length and width of the unit determines the number of legs needed. Pre-painting is an option for the base frame as well as for the high legs.

High legs is installed at the factory up to Geniox 20. For bigger sizes legs will be delivered separately.

## Geniox air handling units for outdoor installation

Geniox air handling units for outdoor installation are always supplied with 8.6" (218 mm) base frame with  $\varnothing$  3" (80 mm) holes. The unit will always be installed on the base frame when delivered.

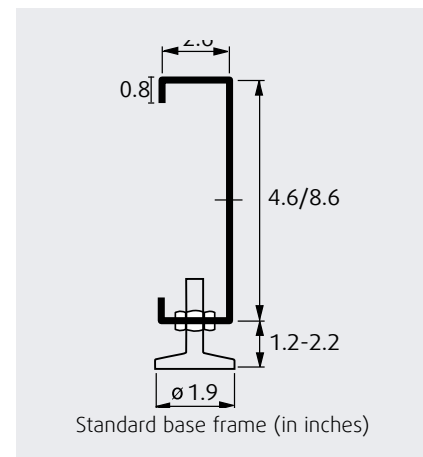

# Base frame with forklift holes

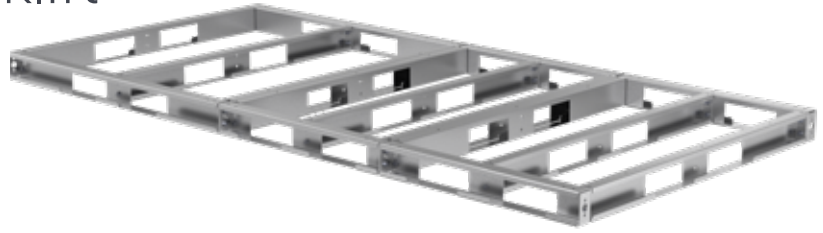

---

## **Geniox air handling units for indoor installation**

In order to save time on the building site it is an option to choose a unit delivered on a base frame with forklift holes. This is an option for Geniox sizes 10-31.

### **Construction**

The height of the base frame is always 4.6" (118 mm). Minimum length of section is 27.6" (700 mm) in order to ensure enough space for the forklift holes. The unit will always be installed on the base frame when delivered, and the base frame will be adjusted to the lengths of the unit sections, max. 113.5" (2882 mm). The base frame is made of .12" (3 mm) galvanized steel sheets. The base frame is coated with ZM310 metallic coating, which provides exceptional corrosion protection.

# Weather hoods

Weather hoods are protective covers for building vents (supply or exhaust) that prevent rain, snow, debris, and pests from entering ventilation systems, ensuring air quality and equipment longevity.



## Overview

Geniox weather hoods are engineered to protect outdoor air intakes and exhaust openings in demanding environments. Designed alongside the Geniox platform, these hoods deliver structural strength, dependable airflow protection, and long-term durability without complicating installation or service.

## Construction

Each weather hood is fabricated from 20-gauge galvanized sheet steel and reinforced with integrated V-profile ribs and cross-member beams. For larger units, dual-hood configurations are used to maintain rigidity and control deflection. The result is a robust assembly that holds its shape and performance in harsh outdoor conditions.

## Installation and Service

Weather hood components are factory-fabricated for straightforward assembly using rivets or approved fasteners. Joints and seams can be sealed using silicone-based or standard commercial sealants to create a tight, weather-resistant installation. The design supports quick field assembly and long-term service access.

## Dimensions

Unit size		10	11	12	14	16	18	20	22	24	27	29	31
Width	W	42.6	46.5	50.5	58.3	66.2	74.1	82.0	89.8	97.7	109.5	117.4	125.3
Height	H	42.6	46.5	50.5	58.3	66.2	74.1	82.0	89.8	97.7	108.8	116.7	124.6
Length	L	23.6	23.6	31.5	35.4	39.4	43.3	47.2	51.2	55.1	59.1	66.9	74.8

Dimensions are in inches



