

# Nordtrack™ I1011 mobile impact crusher

## High performance with small footprint

### Compact and powerful impactor for contractors and as a rental

The Nordtrack™ I1011 mobile impact crusher combines high crushing capacity and end product accuracy with the large hanging screen (optional). This versatile crusher is suitable to work in different jobsites from rock crushing to construction and demolition waste recycling. The small footprint makes it easy to use in tight places and quick to transport with standard trailer between jobsites. Different blowbar options and crusher settings makes any job available with this machine.

**Areas of application:**

-  ●●●● Asphalt recycling
-  ●●●● Construction waste crushing
-  ●●●●● Bricks & tiles
-  ●●● Soft rock
-  ●●●● Coal

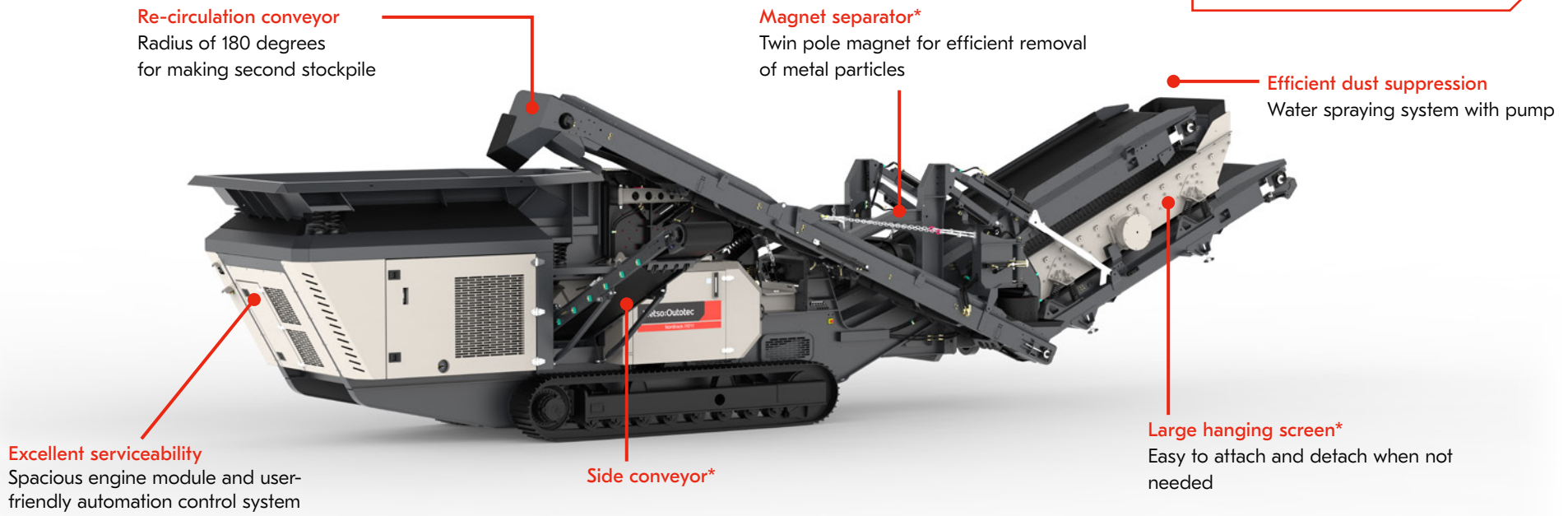

\* Optional, not included in standard delivery



Versatile solution for rental and plant hires



Calibrated and accurate end product



Easy to transport and move on-site



Fuel-efficient direct drive system

# Technical details Nordtrack™ I1011

# Metso

## Crusher



**Feed opening**  
1150 x 800 mm  
(45 x 32")

## Screen\*



**Hanging screen**  
3,660 x 1,530 mm  
(12' x 5')

**Screen angle**  
25 degrees

**Stroke**  
9 mm

## Feeder



**Hopper capacity**  
3.8 m<sup>3</sup> (5 yd<sup>3</sup>)

**Options**  
Multiple grizzly bar and  
punch plate aperture  
options

## Conveyors



**Main conveyor**  
1,200 mm (48") wide

**Product conveyor\***  
1,200 mm (48") wide

**Re-circulation conveyor\***  
500 mm (20") wide

**Side conveyor\***  
600 mm (24") wide

## Engine power options



**Tier 3 (Stage III A):**  
CAT C9.3B 280 kW  
(375 hp)

**Tier 4F:**  
CAT C9.3B 280 kW  
(375 hp)

**Stage V:**  
CAT C9.3B 280 kW  
(375 hp)

## Transport dimensions\*\*

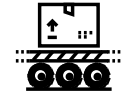

**Weight**  
41.5 t (91,600 lb)

**Width**  
3 m (9' 11")

**Height**  
3.3 m (10' 11")

**Length**  
15.8 m (51' 10")

\* Optional \*\* with screen module

